

Model name:

MMY-MAP_4HT8P-E

MMY-MAP_4T8P-E

SMMS
SUPER MODULAR MULTI SYSTEM



**Engineering
Data Book**

Outdoor units



Notice: Toshiba is committed to continuously improving its products to ensure the highest quality and reliability standards, and to meet local regulations and market requirements. All features and specifications are subject to change without prior notice.









	Safety caution	2
1	System overview	5
	1-1. Allocation standard of model name	5
	1-2. Summary of system equipments	6
2	Equipment selection procedure	12
	2-1. Selection flow chart.....	12
	2-2. Combination conditions for indoor unit and outdoor unit	13
	2-3. Cooling/heating capacity characteristics.....	13
	2-4. Operational temperature range.....	18
3	Refrigerant piping design.....	19
	3-1. Free branching system	19
	3-2. Allowable length/height difference of refrigerant piping	20
	3-3. Selection of refrigerant piping	21
	3-4. Charging requirement with additional refrigerant.....	22
4	Wiring design.....	23
	4-1. General	23
	4-2. Summary of wiring design	23
	4-3. Electrical wiring design	23
	4-4. Outdoor unit power supply.....	23
	4-5. Indoor unit power supply.....	25
	4-6. Design of control wiring	28
5	Outdoor unit.....	30
	5-1. Specifications.....	30
	5-2. Dimensional drawing	37
	5-3. Center of gravity	43
	5-4. Branch header / branch joint.....	44
	5-5. Refrigerant cycle diagram.....	47
	5-6. Wiring diagram.....	49
	5-7. Connecting diagram.....	51
	5-8. Applied control for Outdoor Unit	52
	5-9. Optional printed circuit board (PCB) of outdoor unit.....	55
	5-10. Part load performance	64
	5-11. Sound pressure level data	99



- Before use, read carefully through the “Safety caution” section to ensure correct operation.
- The important contents concerned to the safety are described in the “Safety cautions”. Be sure to keep them. For Indications and their meanings, see the following description.

■ Warning Indications on the Air Conditioner Unit

Warning indication		Description					
 <table border="1"> <tr> <td colspan="2">WARNING</td> </tr> <tr> <td colspan="2">ELECTRICAL SHOCK HAZARD</td> </tr> <tr> <td colspan="2">Disconnect all remote electric power supplies</td> </tr> </table>	WARNING		ELECTRICAL SHOCK HAZARD		Disconnect all remote electric power supplies		<p>WARNING</p> <p>ELECTRICAL SHOCK HAZARD Disconnect all remote electric power supplies before servicing.</p>
WARNING							
ELECTRICAL SHOCK HAZARD							
Disconnect all remote electric power supplies							
 <table border="1"> <tr> <td colspan="2">WARNING</td> </tr> <tr> <td colspan="2">Moving parts. Do not operate unit with grille removed.</td> </tr> </table>	WARNING		Moving parts. Do not operate unit with grille removed.		<p>WARNING</p> <p>Moving parts. Do not operate unit with grille removed. Stop the unit before the servicing.</p>		
WARNING							
Moving parts. Do not operate unit with grille removed.							
 <table border="1"> <tr> <td colspan="2">CAUTION</td> </tr> <tr> <td colspan="2">High temperature parts. You might get burned when removing this panel.</td> </tr> </table>	CAUTION		High temperature parts. You might get burned when removing this panel.		<p>CAUTION</p> <p>High temperature parts. You might get burned when removing this panel.</p>		
CAUTION							
High temperature parts. You might get burned when removing this panel.							
 <table border="1"> <tr> <td colspan="2">CAUTION</td> </tr> <tr> <td colspan="2">Do not touch the aluminum fins of the unit. Doing so may result in injury.</td> </tr> </table>	CAUTION		Do not touch the aluminum fins of the unit. Doing so may result in injury.		<p>CAUTION</p> <p>Do not touch the aluminium fins of the unit. Doing so may result in injury.</p>		
CAUTION							
Do not touch the aluminum fins of the unit. Doing so may result in injury.							
 <table border="1"> <tr> <td colspan="2">CAUTION</td> </tr> <tr> <td colspan="2">BURST HAZARD</td> </tr> <tr> <td colspan="2">Open the service valves before the operation,</td> </tr> </table>	CAUTION		BURST HAZARD		Open the service valves before the operation,		<p>CAUTION</p> <p>BURST HAZARD Open the service valves before the operation, otherwise there might be the burst.</p>
CAUTION							
BURST HAZARD							
Open the service valves before the operation,							
 <table border="1"> <tr> <td colspan="2">CAUTION</td> </tr> <tr> <td colspan="2">Do not climb onto the fan guard.</td> </tr> <tr> <td colspan="2">Doing so may result in</td> </tr> </table>	CAUTION		Do not climb onto the fan guard.		Doing so may result in		<p>CAUTION</p> <p>Do not climb onto the fan guard. Doing so may result in injury.</p>
CAUTION							
Do not climb onto the fan guard.							
Doing so may result in							



■ **Explanation of indications**

⚠ WARNING

Indicates possibilities that a death or serious injury of personnel is caused by an incorrect handling.

⚠ CAUTION

Indicates contents that an injury (*1) or property damage (*2) only may be caused when an incorrect work has been executed.

*1: "Injury" means a hurt, a burn, or an electric shock which does not require hospitalization or a long-term going to the hospital.

*2: "Property damage means an enlarged damage concerned to property, or breakage of materials.

- **After installation work has finished, check there is no trouble by a test operation, and explain using method and maintenance method to the customers based on the Owner's Manual.**
Please ask the customers to keep this Installation Manual together with the Owner's Manual.

⚠ WARNING

Ask a shop or a professional dealer to install the air conditioner.

If you will install by yourself, a fire, an electric shock, or water leak is caused.

Take measures so that the refrigerant does not exceed the limit concentration even if it leaks when installing the air conditioner in a small room.

For the measures not to exceed the limit of concentration, contact the dealer. If the refrigerant leaks and it exceeds the limit of concentration, an accident of oxygen shortage is caused.

Install the air conditioner at a place which is satisfactorily bearable to weight.

If strength is insufficient, the unit may fall down resulting in human injury.

Perform a specified installation work against a strong wind such as typhoon or earthquake.

If the air conditioner is imperfectly installed, an accident by falling or dropping may be caused.

If refrigerant gas leaks during installation work, ventilate the room.

If the leaked refrigerant gas approaches to fire, noxious gas may generate.

After installation work, confirm that refrigerant gas does not leak.

If refrigerant gas leaks in the room, and approaches to fire such as fan heater, stove or kitchen range, generation of noxious gas may be caused.

Never recover refrigerant in the outdoor unit.

Be sure to use a refrigerant recovery device to recover refrigerant in reinstallation or repair work.

Recovery of refrigerant in the outdoor unit is unavailable; otherwise a serious accident such as crack or human injury is caused.

A person qualified for the electric work should deal with the electric construction conforming to the regulations of the local electric company and the Installation Manual. Be sure to use the exclusive circuit.

If there is capacity shortage of the power supply circuit or incomplete installation, a fire or an electric shock is caused.

For cabling, use the specified cables and connect them securely so that external force of cable does not transmit to the terminal connecting section.

If connection or fixing is incomplete, a fire, etc. may be caused.

Be sure to connect earth wire.

Do not connect earth wire to gas pipe, water pipe, lightning rod, nor earth wire of telephone.

If grounding is incomplete, an electric shock is caused.

⚠ CAUTION

Do not install the air conditioner at a place where combustible gas may leak.

If gas leaks and is collected at surrounding the unit, the production of fire may be caused.

Be sure to attach an earth leakage breaker; otherwise an electric shock may be caused.

Using a torque wrench, tighten the flare nut in the specified method.

If the flare nut is exceedingly tightened, the flare nut is broken and a refrigerant leakage may be caused after a long time has passed.



WARNINGS ON REFRIGERANT LEAKAGE

Check of Concentration Limit

The room in which the air conditioner is to be installed requires a design that in the event of refrigerant gas leaking out, its concentration will not exceed a set limit.

The refrigerant R410A which is used in the air conditioner is safe, without the toxicity or combustibility of ammonia, and is not restricted by laws to be imposed which protect the ozone layer. However, since it contains more than air, it poses the risk of suffocation if its concentration should rise excessively.

Suffocation from leakage of R410A is almost nonexistent. With the recent increase in the number of high concentration buildings, however, the installation of multi air conditioner systems is on the increase because of the need for effective use of floor space, individual control, energy conservation by curtailing heat and carrying power etc.

Most importantly, the multi air conditioner system is able to replenish a large amount of refrigerant compared with conventional individual air conditioners. If a single unit of the multi conditioner system is to be installed in a small room, select a suitable model and installation procedure so that if the refrigerant accidentally leaks out, its concentration does not reach the limit (and in the event of an emergency, measures can be made before injury can occur).

In a room where the concentration may exceed the limit, create an opening with adjacent rooms, or install mechanical ventilation combined with a gas leak detection device.

The concentration is as given below.

$$\frac{\text{Total amount of refrigerant (kg)}}{\text{Min. volume of the indoor unit installed room (m}^3\text{)}} \leq \text{Concentration limit (kg/m}^3\text{)}$$

The concentration limit of R410A which is used in multi air conditioners is 0.3 kg/m³.

NOTE 1:

If there are 2 or more refrigerating systems in a single refrigerating device, the amounts of refrigerant should be as charged in each independent device.

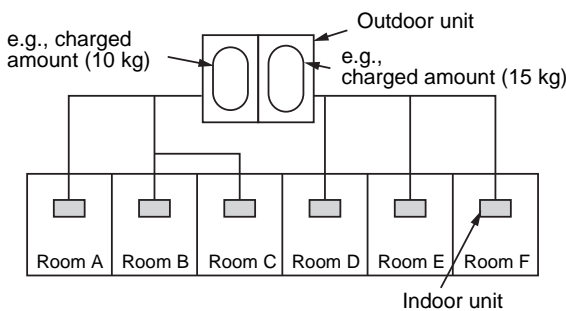

For the amount of charge in this example:

The possible amount of leaked refrigerant gas in rooms A, B and C is 10 kg.

The possible amount of leaked refrigerant gas in rooms D, E and F is 15 kg.

Important

NOTE 2:

The standards for minimum room volume are as follows.

- (1) No partition (shaded portion)

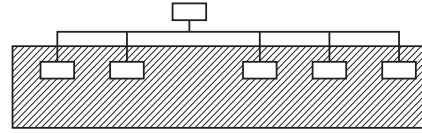

- (2) When there is an effective opening with the adjacent room for ventilation of leaking refrigerant gas (opening without a door, or an opening 0.15 % or larger than the respective floor spaces at the top or bottom of the door).

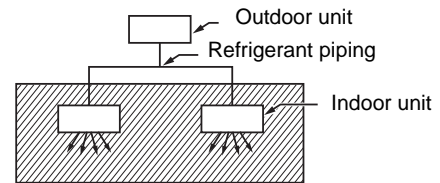

- (3) If an indoor unit is installed in each partitioned room and the refrigerant tubing is interconnected, the smallest room of course becomes the object. But when a mechanical ventilation is installed interlocked with a gas leakage detector in the smallest room where the density limit is exceeded, the volume of the next smallest room becomes the object.

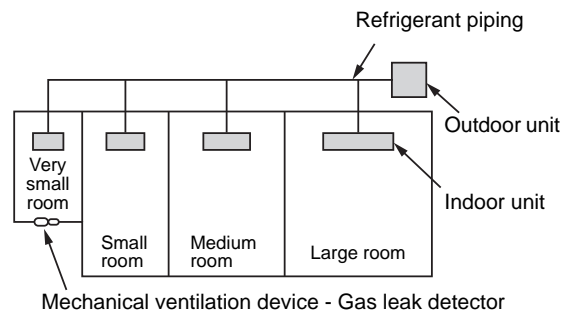

NOTE 3:

The minimum indoor floor area compared with the amount of refrigerant is roughly as follows: (When the ceiling is 2.7 m high)

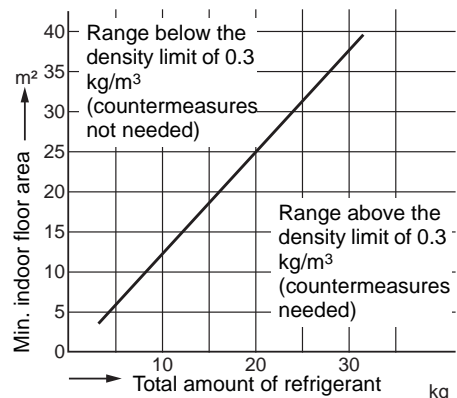



1-1. Allocation standard of model name SMMS-i

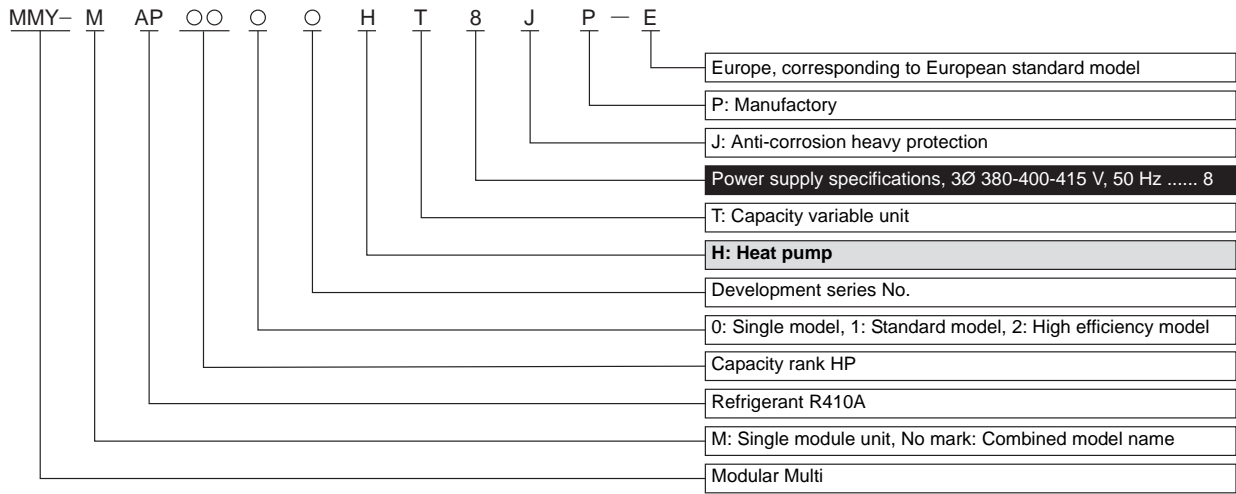



1-2. Summary of system equipments Equipment

1-2-1. Outdoor units

Corresponding HP		Inverter unit					Appearance
		8HP	10HP	12HP	14HP	16HP	
Model name	Heat pump	MMY- MAP0804HT8P-E	MAP1004HT8P-E	MAP1204HT8P-E	MAP1404HT8P-E	MAP1604HT8P-E	
	Cooling only	MMY- MAP0804T8P-E	MAP1004T8P-E	MAP1204T8P-E	MAP1404T8P-E	MAP1604T8P-E	
Cooling capacity (kW)		22.4	28.0	33.5	40.0	45.0	
Heating capacity (kW)		25.0	31.5	37.5	45.0	50.0	
No. of connectable indoor units		13	16	20	23	27	

Combination of outdoor units

Standard model

Corresponding HP		18HP	20HP	22HP	24HP	26HP	28HP	30HP	32HP
Combined Model	MMY-	AP1814HT8P-E	AP2014HT8P-E	AP2214HT8P-E	AP2414HT8P-E	AP2614HT8P-E	AP2814HT8P-E	AP3014HT8P-E	AP3214HT8P-E
	MMY-	AP1814T8P-E	AP2014T8P-E	AP2214T8P-E	AP2414T8P-E	AP2614T8P-E	AP2814T8P-E	AP3014T8P-E	AP3214T8P-E
Cooling capacity (kW)		50.4	56.0	61.5	68.0	73.0	78.5	85.0	90.0
Heating capacity (kW)		56.5	63.0	69.0	76.5	81.5	88.0	95.0	100.0
Combined outdoor units		10HP	10HP	12HP	12HP	16HP	16HP	16HP	16HP
		8HP	10HP	10HP	12HP	10HP	12HP	14HP	16HP
		-	-	-	-	-	-	-	-
		-	-	-	-	-	-	-	-
No. of connectable indoor units		30	33	37	40	43	47	48	48

Corresponding HP		34HP	36HP	38HP	40HP	42HP	44HP	46HP	48HP
Combined Model	MMY-	AP3414HT8P-E	AP3614HT8P-E	AP3814HT8P-E	AP4014HT8P-E	AP4214HT8P-E	AP4414HT8P-E	AP4614HT8P-E	AP4814HT8P-E
	MMY-	AP3414T8P-E	AP3614T8P-E	AP3814T8P-E	AP4014T8P-E	AP4214T8P-E	AP4414T8P-E	AP4614T8P-E	AP4814T8P-E
Cooling capacity (kW)		96.0	101.0	106.5	112.0	118.0	123.5	130.0	135.0
Heating capacity (kW)		108.0	113.0	119.5	127.0	132.0	138.0	145.0	150.0
Combined outdoor units		12HP	12HP	16HP	16HP	16HP	16HP	16HP	16HP
		12HP	12HP	12HP	12HP	14HP	16HP	16HP	16HP
		10HP	12HP	10HP	12HP	12HP	12HP	14HP	16HP
		-	-	-	-	-	-	-	-
No. of connectable indoor units		48	48	48	48	48	48	48	48





High efficiency model

Corresponding HP		16HP	24HP	26HP	28HP	30HP	32HP	34HP	36HP
Combined Model	MMY-	AP1624HT8P-E	AP2424HT8P-E	AP2624HT8P-E	AP2824HT8P-E	AP3024HT8P-E	AP3224HT8P-E	AP3424HT8P-E	AP3624HT8P-E
	MMY-	AP1624T8P-E	AP2424T8P-E	AP2624T8P-E	AP2824T8P-E	AP3024T8P-E	AP3224T8P-E	AP3424T8P-E	AP3624T8P-E
Cooling capacity (kW)		45.0	68.0	73.0	78.5	85.0	90.0	96.0	101.0
Heating capacity (kW)		50.0	76.5	81.5	88.0	95.0	100.0	108.0	113.0
Combined outdoor units		8HP	8HP	10HP	10HP	10HP	8HP	10HP	10HP
		8HP	8HP	8HP	10HP	10HP	8HP	8HP	10HP
		-	8HP	8HP	8HP	10HP	8HP	8HP	8HP
		-	-	-	-	-	8HP	8HP	8HP
No. of connectable indoor units		27	40	43	47	48	48	48	48

Corresponding HP		38HP	40HP	42HP	44HP	46HP	48HP
Combined Model	MMY-	AP3824HT8P-E	AP4024HT8P-E	AP4224HT8P-E	AP4424HT8P-E	AP4624HT8P-E	AP4824HT8P-E
	MMY-	AP3824T8P-E	AP4024T8P-E	AP4224T8P-E	AP4424T8P-E	AP4624T8P-E	AP4824T8P-E
Cooling capacity (kW)		106.5	112.0	118.0	123.5	130.0	135.0
Heating capacity (kW)		119.5	127.0	132.0	138.0	145.0	150.0
Combined outdoor units		10HP	10HP	12HP	12HP	12HP	12HP
		10HP	10HP	10HP	12HP	12HP	12HP
		10HP	10HP	10HP	10HP	12HP	12HP
		8HP	10HP	10HP	10HP	10HP	12HP
No. of connectable indoor units		48	48	48	48	48	48







1-2-2. Indoor unit

Type	Appearance	Model name	Capacity rank	Capacity code	Cooling capacity (kW)	Heating capacity (kW)	
4-way Air Discharge Cassette Type		MMU-AP0092H	009 type	1.00	2.8	3.2	
		MMU-AP0122H	012 type	1.25	3.6	4.0	
		MMU-AP0152H	015 type	1.70	4.5	5.0	
		MMU-AP0182H	018 type	2.00	5.6	6.3	
		MMU-AP0242H	024 type	2.50	7.1	8.0	
		MMU-AP0272H	027 type	3.00	8.0	9.0	
		MMU-AP0302H	030 type	3.20	9.0	10.0	
		MMU-AP0362H	036 type	4.00	11.2	12.5	
		MMU-AP0482H	048 type	5.00	14.0	16.0	
	MMU-AP0562H	056 type	6.00	16.0	18.0		
	4-way Air Discharge Cassette Type		MMU-AP0094HP-E	009 type	1.00	2.8	3.2
			MMU-AP0124HP-E	012 type	1.25	3.6	4.0
			MMU-AP0154HP-E	015 type	1.70	4.5	5.0
			MMU-AP0184HP-E	018 type	2.00	5.6	6.3
			MMU-AP0244HP-E	024 type	2.50	7.1	8.0
			MMU-AP0274HP-E	027 type	3.00	8.0	9.0
			MMU-AP0304HP-E	030 type	3.20	9.0	10.0
			MMU-AP0364HP-E	036 type	4.00	11.2	12.5
			MMU-AP0484HP-E	048 type	5.00	14.0	16.0
MMU-AP0564HP-E	056 type	6.00	16.0	18.0			
Compact 4-way Cassette (600 × 600) Type		MMU-AP0054MH-E	005 type	0.60	1.7	1.9	
		MMU-AP0074MH-E	007 type	0.80	2.2	2.5	
		MMU-AP0094MH-E	009 type	1.00	2.8	3.2	
		MMU-AP0124MH-E	012 type	1.25	3.6	4.0	
		MMU-AP0154MH-E	015 type	1.70	4.5	5.0	
MMU-AP0184MH-E	018 type	2.00	5.6	6.3			
2-way Air Discharge Cassette Type		MMU-AP0072WH	007 type	0.80	2.2	2.5	
		MMU-AP0092WH	009 type	1.00	2.8	3.2	
		MMU-AP0122WH	012 type	1.25	3.6	4.0	
		MMU-AP0152WH	015 type	1.70	4.5	5.0	
		MMU-AP0182WH	018 type	2.00	5.6	6.3	
		MMU-AP0242WH	024 type	2.50	7.1	8.0	
		MMU-AP0272WH	027 type	3.00	8.0	9.0	
		MMU-AP0302WH	030 type	3.20	9.0	10.0	
		MMU-AP0362WH	036 type	4.00	11.2	12.5	
MMU-AP0482WH	048 type	5.00	14.0	16.0			
MMU-AP0562WH	056 type	6.00	16.0	18.0			
1-way Air Discharge Cassette Type		MMU-AP0074YH-E	007 type	0.80	2.2	2.5	
		MMU-AP0094YH-E	009 type	1.00	2.8	3.2	
		MMU-AP0124YH-E	012 type	1.25	3.6	4.0	
		MMU-AP0154SH-E	015 type	1.70	4.5	5.0	
		MMU-AP0184SH-E	018 type	2.00	5.6	6.3	
MMU-AP0244SH-E	024 type	2.50	7.1	8.0			



Type	Appearance	Model name	Capacity rank	Capacity code	Cooling capacity (kW)	Heating capacity (kW)
Concealed Duct Type		MMD-AP0074BH-E	007 type	0.80	2.2	2.5
		MMD-AP0094BH-E	009 type	1.00	2.8	3.2
		MMD-AP0124BH-E	012 type	1.25	3.6	4.0
		MMD-AP0154BH-E	015 type	1.70	4.5	5.0
		MMD-AP0184BH-E	018 type	2.00	5.6	6.3
		MMD-AP0244BH-E	024 type	2.50	7.1	8.0
		MMD-AP0274BH-E	027 type	3.00	8.0	9.0
		MMD-AP0304BH-E	030 type	3.20	9.0	10.0
		MMD-AP0364BH-E	036 type	4.00	11.2	12.5
		MMD-AP0484BH-E	048 type	5.00	14.0	16.0
		MMD-AP0564BH-E	056 type	6.00	16.0	18.0
		MMD-AP0076BH-E	007 type	0.80	2.2	2.5
		MMD-AP0096BH-E	009 type	1.00	2.8	3.2
		MMD-AP0126BH-E	012 type	1.25	3.6	4.0
		MMD-AP0156BH-E	015 type	1.70	4.5	5.0
		MMD-AP0186BH-E	018 type	2.00	5.6	6.3
		MMD-AP0246BH-E	024 type	2.50	7.1	8.0
		MMD-AP0276BH-E	027 type	3.00	8.0	9.0
		MMD-AP0306BH-E	030 type	3.20	9.0	10.0
		MMD-AP0366BH-E	036 type	4.00	11.2	12.5
MMD-AP0486BH-E	048 type	5.00	14.0	16.0		
MMD-AP0566BH-E	056 type	6.00	16.0	18.0		
Concealed Duct High Static Pressure Type		MMD-AP0184H-E	018 type	2.00	5.6	6.3
		MMD-AP0244H-E	024 type	2.50	7.1	8.0
		MMD-AP0274H-E	027 type	3.00	8.0	9.0
		MMD-AP0364H-E	036 type	4.00	11.2	10.0
		MMD-AP0484H-E	048 type	5.00	14.0	16.0
		MMD-AP0724H-E	072 type	8.00	22.4	25.0
MMD-AP0964H-E	096 type	10.00	28.0	31.5		
Slim Duct Type		MMD-AP0054SPH-E	005 type	0.60	1.7	1.9
		MMD-AP0074SPH-E	007 type	0.80	2.2	2.5
		MMD-AP0094SPH-E	009 type	1.00	2.8	3.2
		MMD-AP0124SPH-E	012 type	1.25	3.6	4.0
		MMD-AP0154SPH-E	015 type	1.70	4.5	5.0
		MMD-AP0184SPH-E	018 type	2.00	5.6	6.3
		MMD-AP0244SPH-E	024 type	2.50	7.1	8.0
MMD-AP0274SPH-E	027 type	3.00	8.0	9.0		
Ceiling Type		MMC-AP0154H-E	015 type	1.70	4.5	5.0
		MMC-AP0184H-E	018 type	2.00	5.6	6.3
		MMC-AP0244H-E	024 type	2.50	7.1	8.0
		MMC-AP0274H-E	027 type	3.00	8.0	9.0
		MMC-AP0364H-E	036 type	4.00	11.2	12.5
		MMC-AP0484H-E	048 type	5.00	14.0	16.0
High-wall Type 3 series		MMK-AP0073H	007 type	0.80	2.2	2.5
		MMK-AP0093H	009 type	1.00	2.8	3.2
		MMK-AP0123H	012 type	1.25	3.6	4.0
		MMK-AP0153H	015 type	1.70	4.5	5.0
		MMK-AP0183H	018 type	2.00	5.6	6.3
		MMK-AP0243H	024 type	2.50	7.1	8.0
High-wall Type 4 series		MMK-AP0074MH-E	007 type	0.80	2.2	2.5
		MMK-AP0094MH-E	009 type	1.00	2.8	3.2
		MMK-AP0124MH-E	012 type	1.25	3.6	4.0
Floor Standing Concealed Type		MML-AP0074BH-E	007 type	0.80	2.2	2.5
		MML-AP0094BH-E	009 type	1.00	2.8	3.2
		MML-AP0124BH-E	012 type	1.25	3.6	4.0
		MML-AP0154BH-E	015 type	1.70	4.5	5.0
		MML-AP0184BH-E	018 type	2.00	5.6	6.3
		MML-AP0244BH-E	024 type	2.50	7.1	8.0



Type	Appearance	Model name	Capacity rank	Capacity code	Cooling capacity (kW)	Heating capacity (kW)
Floor Standing Cabinet Type		MML-AP0074H-E	007 type	0.80	2.2	2.5
		MML-AP0094H-E	009 type	1.00	2.8	3.2
		MML-AP0124H-E	012 type	1.25	3.6	4.0
		MML-AP0154H-E	015 type	1.70	4.5	5.0
		MML-AP0184H-E	018 type	2.00	5.6	6.3
		MML-AP0244H-E	024 type	2.50	7.1	8.0
Floor Standing Type		MMF-AP0154H-E	015 type	1.70	4.5	5.0
		MMF-AP0184H-E	018 type	2.00	5.6	6.3
		MMF-AP0244H-E	024 type	2.50	7.1	8.0
		MMF-AP0274H-E	027 type	3.00	8.0	9.0
		MMF-AP0364H-E	036 type	4.00	11.2	10.0
		MMF-AP0484H-E	048 type	5.00	14.0	16.0
Fresh Air Intake Indoor Unit Type		MMD-AP0481HFE	048 type	5.00	14.0	8.9
		MMD-AP0721HFE	072 type	8.00	22.4	13.9
		MMD-AP0961HFE	096 type	10.00	28.0	17.4
Console Type		MML-AP0074NH-E	007 type	0.80	2.2	2.5
		MML-AP0094NH-E	009 type	1.00	2.8	3.2
		MML-AP0124NH-E	012 type	1.25	3.6	4.0
		MML-AP0154NH-E	015 type	1.70	4.5	5.0
		MML-AP0184NH-E	018 type	2.00	5.6	6.3
Air to Air Heat exchanger with DX-coil Type		MMD-VN502HEXE	009 type	1.00	4.10(1.30) *	5.53(2.33) *
		MMD-VN802HEXE	015 type	1.70	6.56(2.06) *	8.61(3.61) *
		MMD-VN1002HEXE	018 type	2.00	8.25(2.32) *	10.92(4.32) *
		MMD-VNK502HEXE	009 type	1.00	4.10(1.30) *	5.53(2.33) *
		MMD-VNK802HEXE	015 type	1.70	6.56(2.06) *	8.61(3.61) *
		MMD-VNK1002HEXE	018 type	2.00	8.25(2.32) *	10.92(4.32) *

* : The figures in () indicate the heat reclaimed from the heat recovery ventilator.



1-2-3. Branching joints and headers

Name	Model name	Appearance
Y-shape branching joint	RBM-BY55E	
	RBM-BY105E	
	RBM-BY205E	
	RBM-BY305E	
4-branching header	RBM-HY1043E	
	RBM-HY2043E	
8-branching header	RBM-HY1083E	
	RBM-HY2083E	
Branching joint for connection of outdoor units	RBM-BT14E	
	RBM-BT24E	

1-2-4. Remote controllers

Name	Model Name	Remarks
Wired remote controller	RBC-AMT32E	
Simple wired remote controller	RBC-AS21E2, RBC-AS41E	
Wireless remote controller kit	RBC-AX32U(W)-E RBC-AX32U(WS)-E	For 4-way Air Discharge Cassette
	RBC-AX32CE2	For Under Ceiling, 1-way Air Discharge Cassette SH
	TCB-AX32E	For Compact 4-way Cassette, 1-way air Discharge Cassette YH, Concealed Duct Standard, Slim Duct, Floor Standing Cabinet, Floor Standing
	RBC-AX23UW(W)-E	For 2-way Air Discharge Cassette
ON-OFF controller	TCB-CC163TLE2	
Central remote controller	TCB-SC642TLE2	
	BMS-CM1280TLE	
Schedule timer	TCB-EXS21TLE	
Remote controller with schedule timer (7-day timer function)	RBC-AMS41E	
Lite-Vision plus Remote Controller	RBC-AMS51E-EN/ES	-EN : English, Italian, Polish, Greece, Russian, Turkish -ES : English, Spanish, Portuguese, French, Dutch, German
Wired remote controller for Air to Air Heat Exchanger with DX coil unit	NRC-01HE	

1-2-5. Optional PCB of outdoor unit

Name	Model Name	Remarks
Power peak-cut control board	TCB-PCDM4E	
External master ON/OFF control board	TCB-PCMO4E	
Output control board	TCB-PCIN4E	



1-2-6. Controls

Name	Model Name	Remarks
Touch Screen Controller	BMS-TP0641ACE BMS-TP5121ACE BMS-TP0641PWE BMS-TP5121PWE	ACE: Without energy monitoring function PWE: With energy monitoring function 0641: Maximum 64 indoor units connectable 5121: Maximum 512 indoor units connectable
Smart BMS manager	BMS-SM1280HTLE	
Smart BMS manager with data analyzer	BMS-SM1280ETLE	
WEB Based Controller	BMS-WB2561PWE BMS-WB01GTE	
TCS-NET Relay Interface	BMS-IFLSV4E	
Energy Monitoring Relay Interface	BMS-IFWH5E	
Digital I/O Relay Interface	BMS-IFDD03E	
LonWorks LN Interface	TCB-IFLN642TLE	
BACnet Server	BMS-LSV6E BMS-STBN08E	
Modbus Interface	TCB-IFMB641TLE	
Analog Interface	TCB-IFCB640TLE	



2-1. Selection flow chart

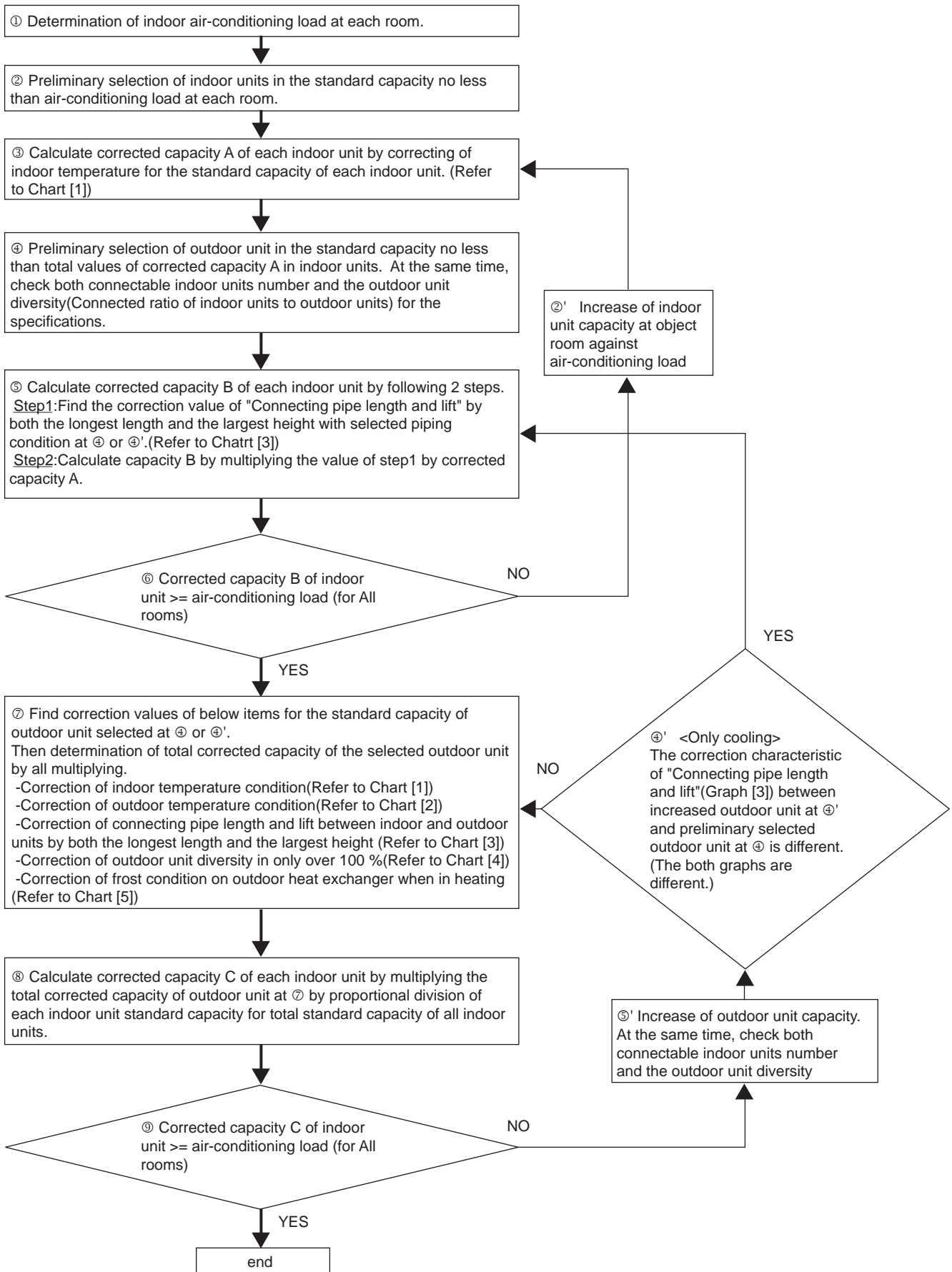



2-2. Combination conditions for indoor unit and outdoor unit

Indoor unit can connect 50 % to 135 % of Outdoor unit capacity.

NOTE:

Height difference between indoor unit over 15 m, combination conditions for indoor and outdoor unit is 50 % to 105 %.

2-3. Cooling/heating capacity characteristics

2-3-1. Correction charts for cooling capacity calculation

[1] Indoor air wet bulb temperature vs. capacity correction value

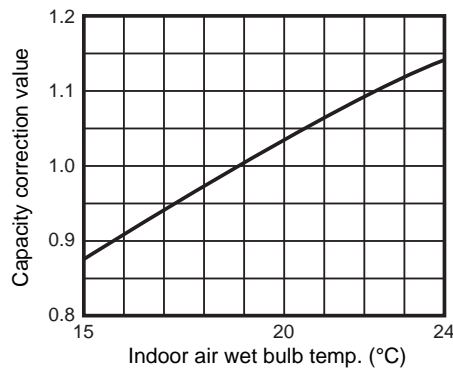

[2] Outdoor air dry bulb temperature vs. capacity correction value

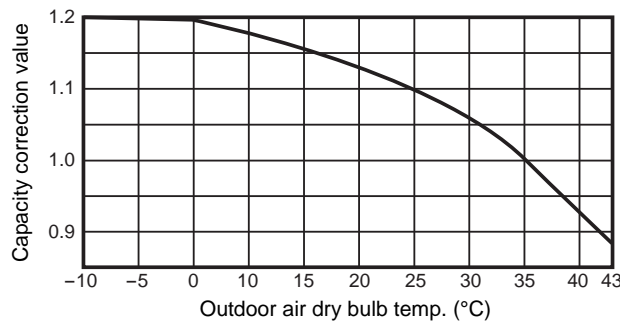

[3] Connecting pipe length and lift difference between indoor and outdoor units vs. capacity correction value

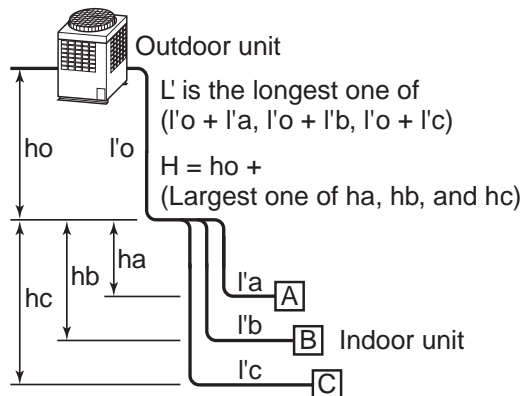

HP	Standard model		High efficiency model	
	Pipe length	Graph	Pipe length	Graph
8	210	A1		
10	210	B1		
12	210	A1		
14	210	A1		
16	210	A1	220	A2
18	220	B2		
20	220	B2		
22	220	A2		
24	220	A2	235	A3
26	220	B2	235	B3
28	220	B2	235	B3
30	220	B2	235	B3
32	220	B2	235	B3
34	235	B3	235	B3
36	235	A3	235	A3
38	235	B3	235	B3
40	235	B3	235	B3
42	235	B3	235	B3
44	235	B3	235	B3
46	185	C1	185	C1
48	185	C1	185	C1

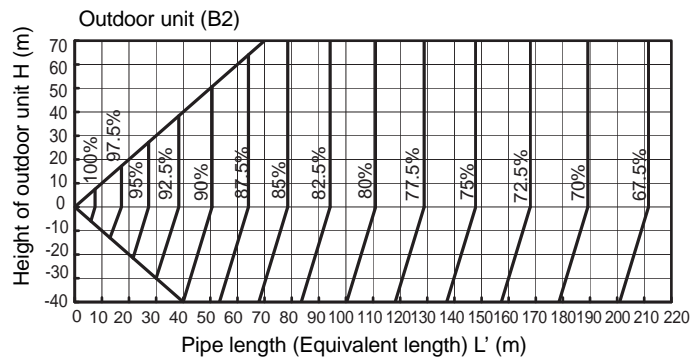



2-3-2. Correction charts for heating capacity calculation

[1] Indoor air dry bulb temperature vs. capacity correction value

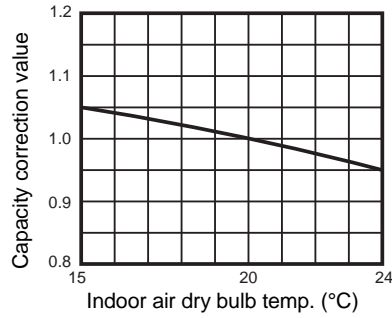

[2] Outdoor air wet bulb temperature vs. capacity correction value

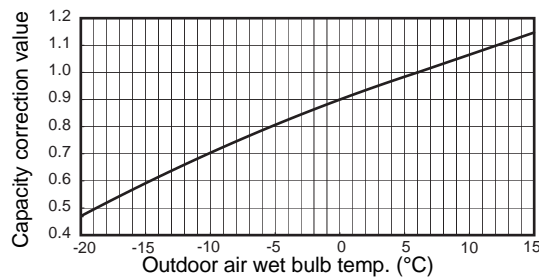

[3] Connecting pipe length and lift difference between indoor and outdoor units vs. capacity correction value

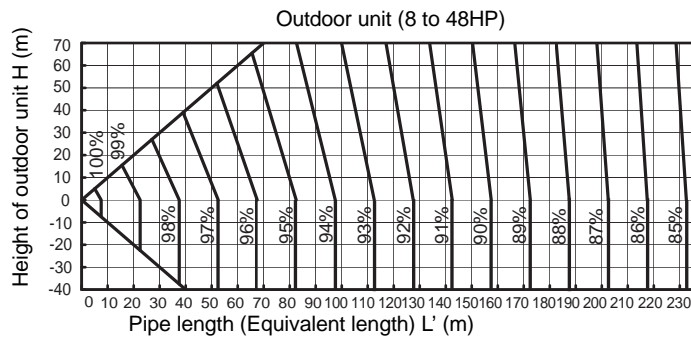
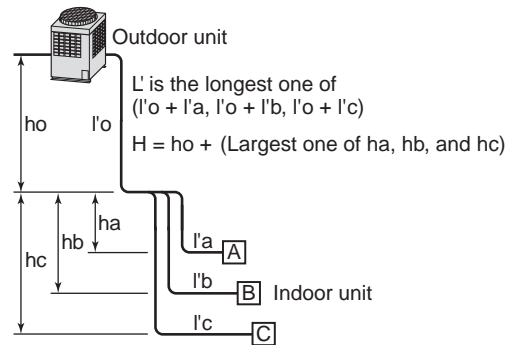



[4]* Correction of outdoor unit diversity

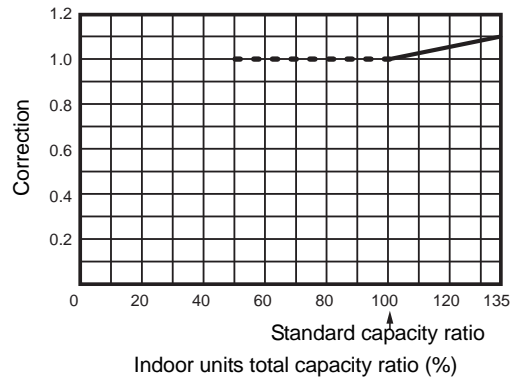

*: Coefficient to use for the correction of the outdoor unit capacity when the total capacity of the indoor units are not equal to the outdoor unit capacity.

2-3-3. Capacity correction in case of frost on the outdoor heat exchanger when in heating

Correct the heating capacity when frost can be found on the outdoor heat exchanger.

Heating capacity = Capacity after correction of outdoor unit x Correction value of capacity resulted from frost
 (Capacity after correction of outdoor unit: Heating capacity calculated in the above item 2.)

[5] Capacity correction in case of frost on the outdoor heat exchanger

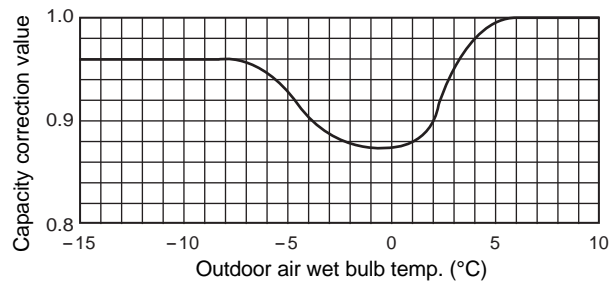

2-3-4. Rated conditions

Cooling: Indoor air temperature 27 °C DB / 19 °C WB, Outdoor air temperature 35 °C DB

Heating: Indoor air temperature 20 °C DB, Outdoor air temperature 7 °C DB / 6 °C WB



2-4. Operational temperature range

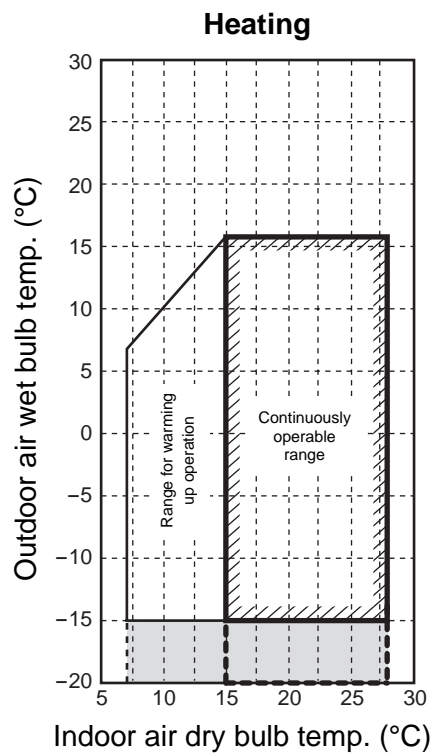
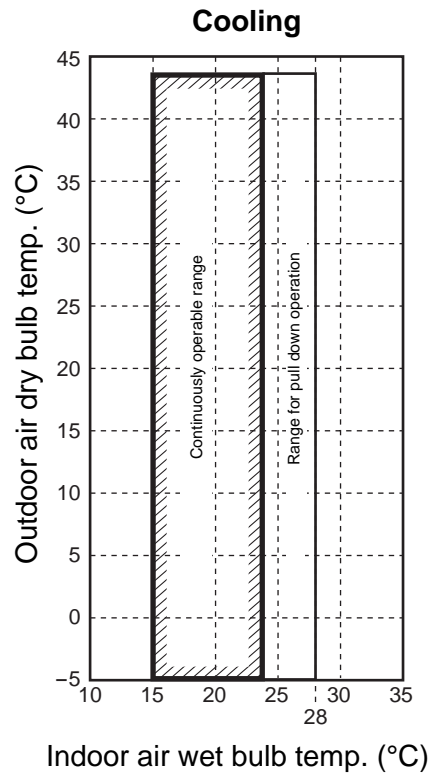

The unit will operate down to an outdoor temperature of -20 °C, however considerable performance decrease will be expected below -15 °C. Therefore please consider installation location/ surroundings and system design when expected to operate between -15 °C and -20 °C.



3-1. Free branching system

- [1] Line branching system
- [2] Header branching system
- [3] Header branching system after line branching
- [4] Line branching system after header branching
- [5] Header branching system after header branching

The above five branching systems enable to dramatically increase the flexibility of refrigerant piping design.

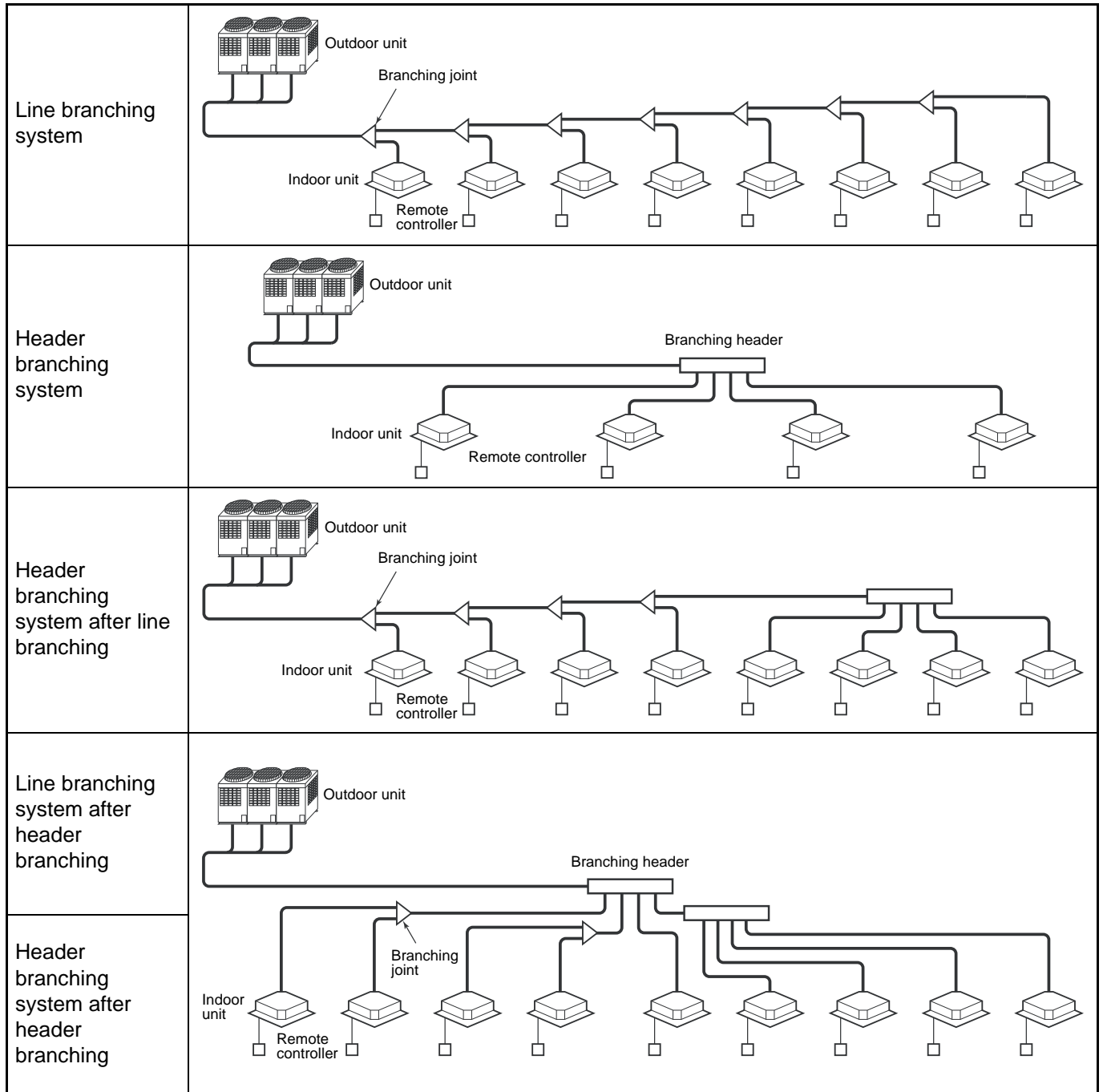



3-2. Allowable length/height difference of refrigerant piping

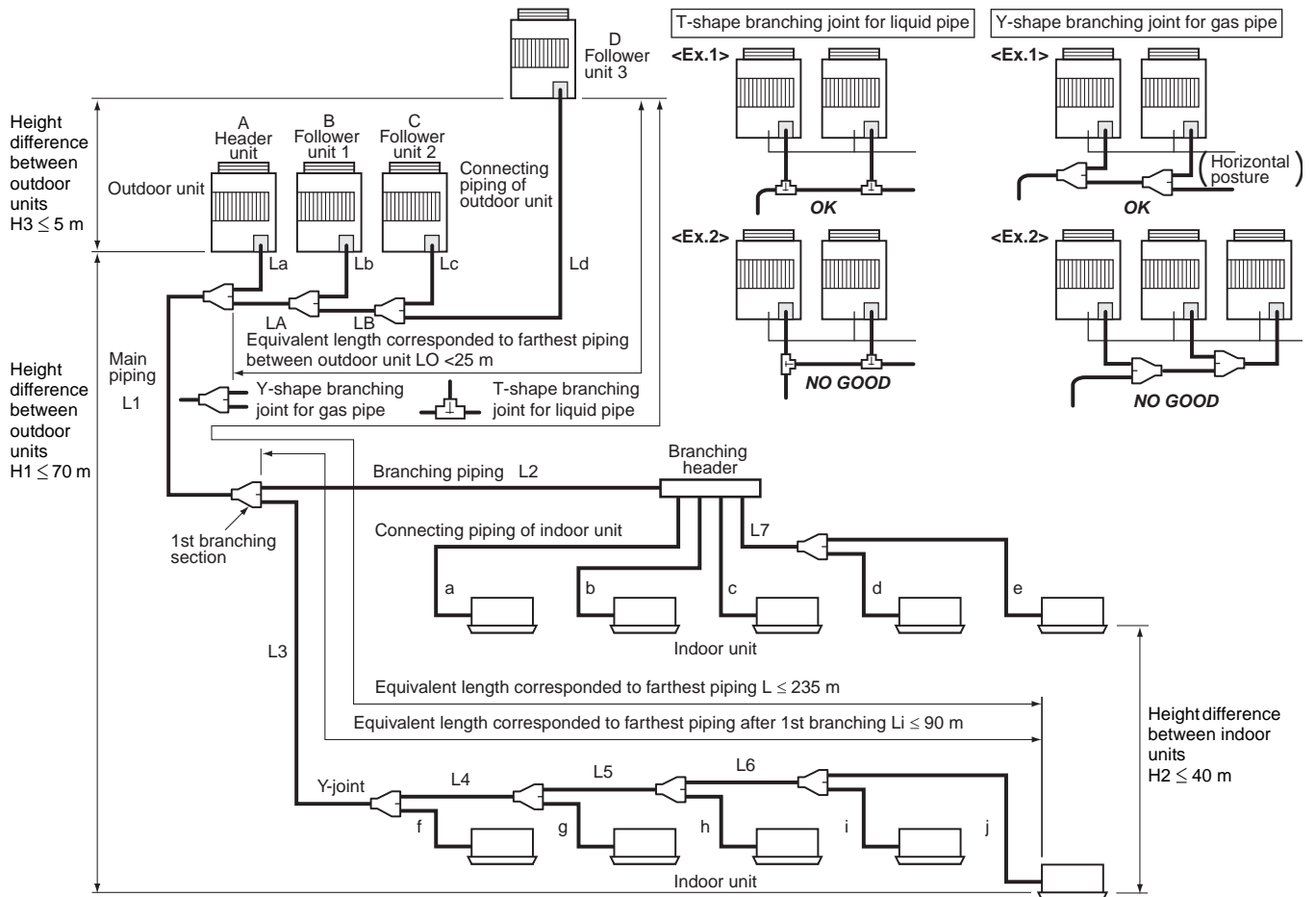

System restrictions

Max. No. of combined outdoor units	4 units	
Max. capacity of combined outdoor units	48 HP	
Max. No. of connected indoor units	48 units	
Max. capacity of combined indoor units	H2 ≤ 15	135 %
	H2 > 15	105 %

- Note 1)** Combination of outdoor units: Header unit (1 unit) + Follower units (0 to 3 units). Header unit is the outdoor unit nearest to the connected indoor units.
- Note 2)** Install the outdoor units in order of capacity. (Header unit ≥ Follower unit 1 ≥ Follower unit 2 ≥ Follower unit 3)
- Note 3)** Use Y-shape branching joint in connecting of gas pipe for outdoor unit, and install horizontally.
- Note 4)** Piping to indoor units shall be perpendicular to piping to the header outdoor unit as <Ex.1>. Do not connect piping to indoor units in the same direction of header outdoor unit as T-shape branching joint for liquid pipe of <Ex.2>.

Farthest piping length L(*1) by capacity of outdoor units

Capacity (HP)	Standard model				High efficiency model		
	8 - 16	18 - 32	34 - 44	46, 48	16	24 - 44	46, 48
Equivalent length (m)	210	220	235	185	210	235	185
Real length (m)	170	180	190	155	180	190	155

Note: All values of above table decrease 25 m when H1 exceeds 3 m.

Allowable length and height difference of refrigerant piping

			Allowable value	Piping section
Piping length	Total extension of pipe (Liquid pipe, real length)	Below 34HP	300 m	LA + LB + La + Lb + Lc + Ld + L1 + L2 + L3 + L4 + L5 + L6 + L7 + a + b + c + d + e + f + g + h + i + j
		34HP or more	500 m	
	Farthest piping Length L (*1)	Equivalent length	235 m	
		Real length	190 m	
	Equivalent length of farthest piping from 1st branching Li (*1)		90 m (*2)	
	Equivalent length of farthest piping between outdoor units LO (*1)		25 m	
	Max. equivalent length of main piping	Equivalent length	120 m (*3)	
		Real length	100 m (*3)	
Max. equivalent length of outdoor unit connecting piping		10 m		
Max. real length of indoor unit connecting piping		30 m		
Max. equivalent length between branches		50 m		
Difference in height	Height between indoor and outdoor units H1	Upper outdoor unit	70 m (*4)	
		Lower outdoor unit	40 m (*5)	
	Height between indoor units H2		40 m	
	Height between outdoor units H3		5 m	

(*1) : (D) is outdoor unit furthest from the 1st branch and (j) is the indoor unit furthest from the 1st branch.

(*2) : If the height difference (H1) between indoor and outdoor unit exceeds 3 m, set 65 m or less.

(*3) : If the max. combined outdoor unit capacity is 46HP or more, then max. equivalent length is 70 m or less (real length is 50 m or less).

(*4) : If the height difference (H2) between indoor units exceeds 3 m, set 50 m or less.

(*5) : If the height difference (H2) between indoor units exceeds 3 m, set 30 m or less.



3-3. Selection of refrigerant piping

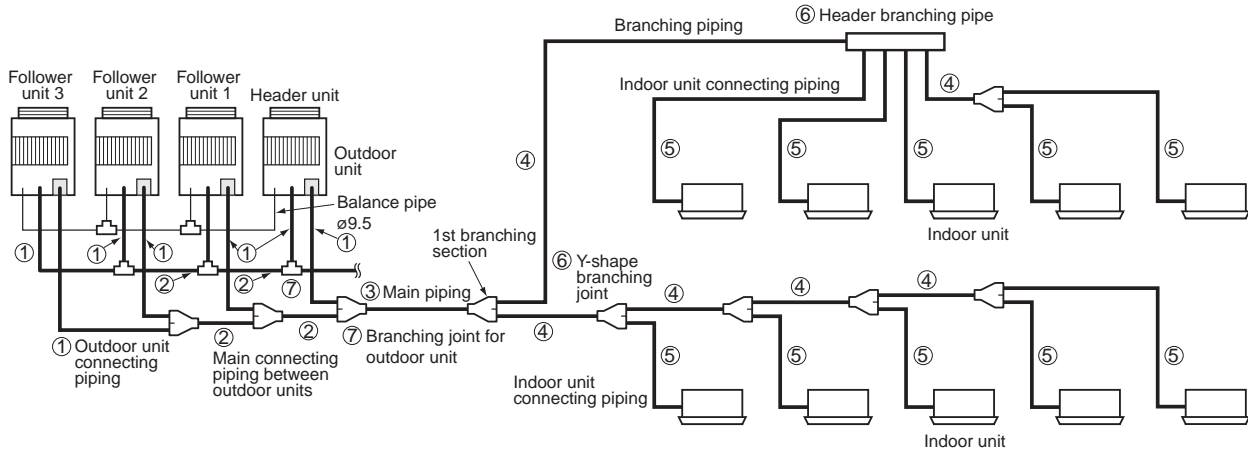

① Pipe size of outdoor unit (Table 1)

Model name MMY-	Gas side	Liquid side
MAP0804*	ø22.2	ø12.7
MAP1004*	ø22.2	ø12.7
MAP1204*	ø28.6	ø12.7
MAP1404*	ø28.6	ø15.9
MAP1604*	ø28.6	ø15.9

② Connecting pipe size between outdoor units (Table 2)

Total capacity code of outdoor units at downstream side *1	Gas side	Liquid side	Balance pipe
16 to below 22	ø28.6	ø15.9	ø9.5
22 to below 26	ø34.9	ø15.9	
26 to below 36	ø34.9	ø19.1	
36 or more	ø41.3	ø22.2	

③ Size of main pipe (Table 3)

Total capacity code of all outdoor units *1	Gas side	Liquid side
Below 6	ø15.9	ø9.5
6 to below 8	ø19.1	ø9.5
8 to below 12	ø22.2	ø12.7
12 to below 14	ø28.6	ø12.7
14 to below 22	ø28.6	ø15.9
22 to below 36	ø34.9	ø19.1
36 to below 46	ø41.3	ø22.2
46 or more *7	ø41.3	ø22.2

Determine thickness of the main pipe according to capacity of the outdoor units.

④ Pipe size between branching sections (Table 4)*5

SMMS-i 8HP to 48HP		
Total capacity code of indoor units at downstream side *1	Gas side	Liquid side
2.4 or less	ø12.7	ø9.5
2.4 to below 6.4	ø15.9	ø9.5
6.4 to below 12.2	ø22.2	ø12.7
12.2 to below 20.2	ø28.6	ø15.9
20.2 to below 35.2	ø34.9	ø19.1
35.2 or more	ø41.3	ø22.2

If the total capacity code value of indoor units exceeds that of the outdoor units, apply the capacity code of outdoor units.

⑤ Piping of indoor unit (Table 5)

Capacity rank		Gas side	Liquid side
005 type to 012 type	Actual length 15 m or less	ø9.5	ø6.4
	Actual length exceeds 15 m	ø12.7	ø6.4
015 type to 018 type		ø12.7	ø6.4
024 type to 056 type		ø15.9	ø9.5
072 type to 096 type		ø22.2	ø12.7

*1 Code is determined according to the capacity rank.

*2 When using a branching joint for the 1st branch, select according to capacity code of the outdoor unit.

*3 For 1 line after branching header indoor units with a maximum capacity code of 6.0 in total can be connected.

*4 If the pipe size is ø19.0 or more, use a suitable material as detailed in the installation manual.

*5 If the piping size becomes over main piping size, select the size same as main piping.

*6 When the first branch is a header with the outdoor total capacity codes of 12 to 26, apply the model RBM-HY2043E(4-branch) or RBM-HY2083E(8-branch) regardless of the total capacity codes of the down-stream indoor units.

*7 The maximum equivalent length of main pipe should be 70m or shorter.

*8 When the sum of capacity code of indoor units exceeds the capacity code of outdoor units, select according to capacity code of the outdoor units.

⑥ Selection of branching section (Table 6)

Y-shape branching joint *2 *3 *8	Total capacity code of indoor unit *1		Model name
	Below 6.4		
	6.4 to below 14.2		RBM-BY55E
	14.2 to below 25.2		RBM-BY105E
	25.2 or more		RBM-BY205E RBM-BY305E
Branching header *2 *3 *6 *8	For 4 branching	Below 14.2	RBM-HY1043E
		14.2 to below 25.2	RBM-HY2043E
	For 8 branching	Below 14.2	RBM-HY1083E
		14.2 to below 25.2	RBM-HY2083E

⑦ Selection of branching joint for outdoor unit (Table 7)

	Total capacity code of outdoor unit	Joints			Model name
		Gas (Y-shape)	Liquid (T-shape)	Balance (T-shape)	
Branching joint for outdoor unit	Below 26				RBM-BT14E
	26 or more				RBM-BT24E

⑧ Minimum wall thickness for R410A application (Table 8)

Soft	Half hard or hard	OD (Inch)	OD (mm)	Minimum wall thickness (mm)
OK	OK	1/4"	6.35	0.80
OK	OK	3/8"	9.52	0.80
OK	OK	1/2"	12.70	0.80
OK	OK	5/8"	15.88	1.00
No Good*4	OK	3/4"	19.05	1.00
No Good*4	OK	7/8"	22.20	1.00
No Good*4	OK	1.1/8"	28.58	1.00
No Good*4	OK	1.3/8"	34.92	1.10
No Good*4	OK	1.5/8"	41.28	1.25



3-4. Charging requirement with additional refrigerant

Calculating the amount of additional refrigerant required

Refrigerant in the system when shipped from the factory

		8HP	10HP	12HP	14HP	16HP
Refrigerant amount charged in factory	Heat pump model	11.5 kg	11.5 kg	11.5 kg	11.5 kg	11.5 kg
	Cooling only model	10.5 kg	10.5 kg	10.5 kg	11.5 kg	11.5 kg

When the system is charged with refrigerant at the factory, the amount of refrigerant needed for the pipes at the site is not included. Therefore, calculate the additional amount needed and add the required amount to the system.

(Calculation)

Additional refrigerant charge amount is calculated based on the size of liquid pipe at site and its real length.

$$\text{Additional refrigerant charge amount at site} = \text{Real length of liquid pipe} \times \text{Additional refrigerant charge amount per liquid pipe 1 m (Table 1)} + \text{Compensation by system HP (Table 2)}$$

Example : Additional charge amount R (kg) = (L1 x 0.025 kg/m) + (L2 x 0.055 kg/m) + (L3 x 0.105 kg/m) + (3.0 kg)
 L1 : Real total length of liquid pipe ø6.4 (m)
 L2 : Real total length of liquid pipe ø9.5 (m)
 L3 : Real total length of liquid pipe ø12.7 (m)

Table 1

Pipe dia. at liquid side	ø6.4	ø9.5	ø12.7	ø15.9	ø19.0	ø22.2
Additional refrigerant amount/1m	0.025 kg	0.055 kg	0.105 kg	0.160 kg	0.250 kg	0.350 kg

Table 2

Standard model

Combined horse power (HP)	Outdoor combination (HP)			Compensation by System HP (kg)
8	8			1.5
10	10			2.5
12	12			3.5
14	14			8.5
16	16			10.5
18	10	8		0.0
20	10	10		3.0
22	12	10		5.0
24	12	12		7.5
26	16	10		8.5
28	16	12		9.5
30	16	14		11.5
32	16	16		12.5
34	12	12	10	3.0
36	12	12	12	4.0
38	16	12	10	6.0
40	16	12	12	7.0
42	16	14	12	8.0
44	16	16	12	10.0
46	16	16	14	12.0
48	16	16	16	14.0

High efficiency model

Combined horse power (HP)	Outdoor combination (HP)				Compensation by System HP (kg)
-					-
-					-
-					-
-					-
16	8	8			0.0
-					-
-					-
-					-
24	8	8	8		-4.0
26	10	8	8		-4.0
28	10	10	8		-2.0
30	10	10	10		0.0
32	8	8	8	8	-6.0
34	10	8	8	8	-6.0
36	10	10	8	8	-6.0
38	10	10	10	8	-6.0
40	10	10	10	10	-5.0
42	12	10	10	10	-4.0
44	12	12	10	10	-2.0
46	12	12	12	10	0.0
48	12	12	12	12	2.0



4-1. General

- Perform wiring of the power supply in conformance with the regulations of the local electric company.
- For cabling of the power supply of the indoor unit and the inter-unit cabling between indoor and outdoor units, refer to the Installation Manual of indoor unit.
- Never connect power supply to the terminal block (U1, U2, U3, U4, U5, U6) for control wiring. (The equipment breaks down.)
- Arrange the cables so that the electric wires do not come to contact with high-temperature part of the pipe; otherwise coating melts and an accident may be caused.
- After connecting cable to the terminal block, take off the trap and then fix the cable with cable clamp.
- Do not turn on power of the indoor unit until vacuuming of the refrigerant pipe will finish.

4-2. Summary of wiring design

- | | | |
|--|---|--|
| Design of outdoor unit power supply | } | • Select the wiring depending on MCA. |
| | | • Be sure to set the earth leakage breaker from the viewpoint of safety. |
| Design of indoor unit power supply | } | • Select the wiring depending on total current of indoor units. |
| | | • Determine the wire size for the length rules. |
| | | • Be sure to set the earth leakage breaker from the viewpoint of safety. |
| Design of control wiring | } | • Design each control wiring. |
| | | Between outdoor and indoor units, |
| | | Between indoor units/outdoor units |
| | | Between indoor unit and remote controller, central control, BMS |
| | | • Select the wire size and type depending on the length rules. |

4-3. Electrical wiring design

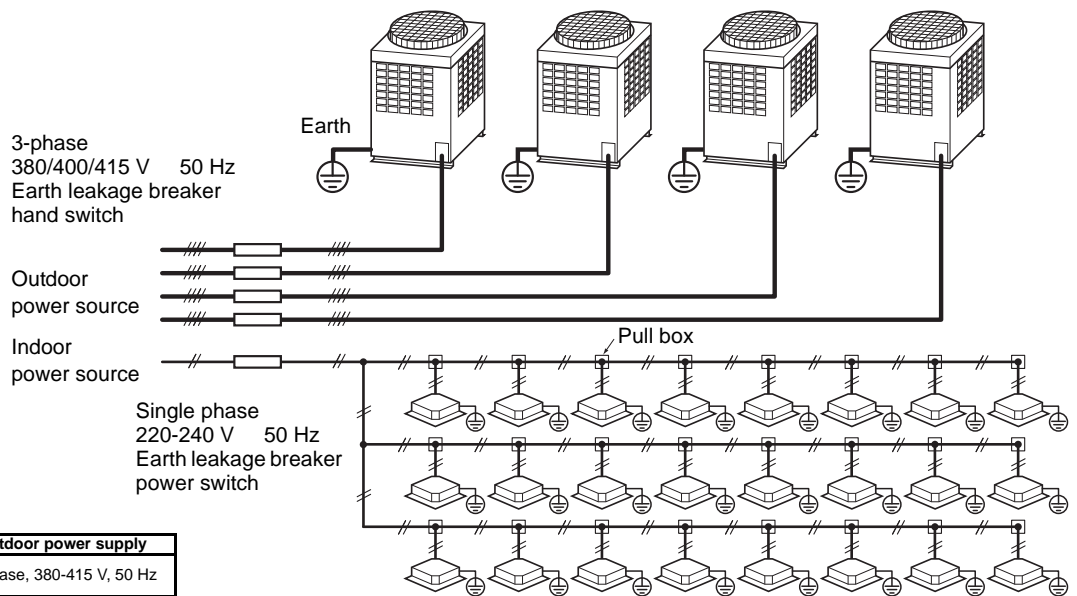

- Wiring size must comply with the applicable local and national code.
- Determine the wire size for the indoor unit according to the number of connected indoor units downstream.

4-4. Outdoor unit power supply

- Select the power supply cabling and fuse of each outdoor unit from the following specifications:
cable 4-core, in conformance with Design 60245 IEC 66
- Do not connect the outdoor units by crossing outside of them, but connect them via the terminal block (L1, L2, L3, N).

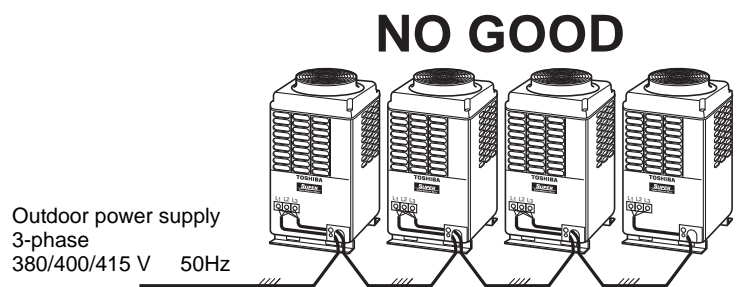



Outdoor unit data
Standard model

Type	HP	Heat Pump Model MMY-	Cooling Only Model MMY-	Power Supply		Voltage Range		Compressor				Fan Motor (kW)	MCA (A)	MOCp (A)
				Phase and frequency	Nominal Voltage	Min. (V)	Max (V)	Unit No.1 (kW)	Unit No.2 (kW)	Unit No.3 (kW)	Unit No.4 (kW)			
Single unit	8	MAP0804HT8P-E	MAP0804T8P-E	3N~50 Hz	380-400-415 V	342	456	2.3 x 2				1.0	23.5	32
	10	MAP1004HT8P-E	MAP1004T8P-E	3N~50 Hz	380-400-415 V	342	456	3.1 x 2				1.0	25.5	32
	12	MAP1204HT8P-E	MAP1204T8P-E	3N~50 Hz	380-400-415 V	342	456	4.2 x 2				1.0	28.5	40
	14	MAP1404HT8P-E	MAP1404T8P-E	3N~50 Hz	380-400-415 V	342	456	3.0 x 3				1.0	33.2	40
	16	MAP1604HT8P-E	MAP1604T8P-E	3N~50 Hz	380-400-415 V	342	456	3.6 x 3				1.0	36.5	50
	18	AP1814HT8P-E	AP1814T8P-E	3N~50 Hz	380-400-415 V	342	456	3.1 x 2	2.3 x 2			1.0 x 2	49.0	63
	20	AP2014HT8P-E	AP2014T8P-E	3N~50 Hz	380-400-415 V	342	456	3.1 x 2	3.1 x 2			1.0 x 2	51.0	63
	22	AP2214HT8P-E	AP2214T8P-E	3N~50 Hz	380-400-415 V	342	456	4.2 x 2	3.1 x 2			1.0 x 2	54.0	63
	24	AP2414HT8P-E	AP2414T8P-E	3N~50 Hz	380-400-415 V	342	456	4.2 x 2	4.2 x 2			1.0 x 2	57.0	63
	26	AP2614HT8P-E	AP2614T8P-E	3N~50 Hz	380-400-415 V	342	456	3.6 x 3	3.1 x 2			1.0 x 2	62.0	80
	28	AP2814HT8P-E	AP2814T8P-E	3N~50 Hz	380-400-415 V	342	456	3.6 x 3	4.2 x 2			1.0 x 2	65.0	80
	30	AP3014HT8P-E	AP3014T8P-E	3N~50 Hz	380-400-415 V	342	456	3.6 x 3	3.0 x 3			1.0 x 2	69.7	80
	32	AP3214HT8P-E	AP3214T8P-E	3N~50 Hz	380-400-415 V	342	456	3.6 x 3	3.6 x 3			1.0 x 2	73.0	100
	34	AP3414HT8P-E	AP3414T8P-E	3N~50 Hz	380-400-415 V	342	456	4.2 x 2	4.2 x 2	3.1 x 2		1.0 x 3	82.5	100
	36	AP3614HT8P-E	AP3614T8P-E	3N~50 Hz	380-400-415 V	342	456	4.2 x 2	4.2 x 2	4.2 x 2		1.0 x 3	85.5	100
	38	AP3814HT8P-E	AP3814T8P-E	3N~50 Hz	380-400-415 V	342	456	3.6 x 3	4.2 x 2	3.1 x 2		1.0 x 3	90.5	100
40	AP4014HT8P-E	AP4014T8P-E	3N~50 Hz	380-400-415 V	342	456	3.6 x 3	4.2 x 2	4.2 x 2		1.0 x 3	93.5	125	
42	AP4214HT8P-E	AP4214T8P-E	3N~50 Hz	380-400-415 V	342	456	3.6 x 3	3.0 x 3	4.2 x 2		1.0 x 3	98.2	125	
44	AP4414HT8P-E	AP4414T8P-E	3N~50 Hz	380-400-415 V	342	456	3.6 x 3	3.6 x 3	4.2 x 2		1.0 x 3	101.5	125	
46	AP4614HT8P-E	AP4614T8P-E	3N~50 Hz	380-400-415 V	342	456	3.6 x 3	3.6 x 3	3.0 x 3		1.0 x 3	106.2	125	
48	AP4814HT8P-E	AP4814T8P-E	3N~50 Hz	380-400-415 V	342	456	3.6 x 3	3.6 x 3	3.6 x 3		1.0 x 3	109.5	125	

High efficiency model

Type	HP	Heat Pump Model MMY-	Cooling Only Model MMY-	Power Supply		Voltage Range		Compressor				Fan Motor (kW)	MCA (A)	MOCp (A)
				Phase and frequency	Nominal Voltage	Min. (V)	Max (V)	Unit No.1 (kW)	Unit No.2 (kW)	Unit No.3 (kW)	Unit No.4 (kW)			
Combination of outdoor unit	16	AP1624HT8P-E	AP1624T8P-E	3N~50 Hz	380-400-415 V	342	456	2.3 x 2	2.3 x 2			1.0 x 2	46.9	63
	24	AP2424HT8P-E	AP2424T8P-E	3N~50 Hz	380-400-415 V	342	456	2.3 x 2	2.3 x 2	2.3 x 2		1.0 x 3	70.4	80
	26	AP2624HT8P-E	AP2624T8P-E	3N~50 Hz	380-400-415 V	342	456	3.1 x 2	2.3 x 2	2.3 x 2		1.0 x 3	72.4	80
	28	AP2824HT8P-E	AP2824T8P-E	3N~50 Hz	380-400-415 V	342	456	3.1 x 2	3.1 x 2	2.3 x 2		1.0 x 3	74.5	100
	30	AP3024HT8P-E	AP3024T8P-E	3N~50 Hz	380-400-415 V	342	456	3.1 x 2	3.1 x 2	3.1 x 2		1.0 x 3	76.5	100
	32	AP3224HT8P-E	AP3224T8P-E	3N~50 Hz	380-400-415 V	342	456	2.3 x 2	2.3 x 2	2.3 x 2	2.3 x 2	2.3 x 2	93.8	125
	34	AP3424HT8P-E	AP3424T8P-E	3N~50 Hz	380-400-415 V	342	456	3.1 x 2	2.3 x 2	2.3 x 2		1.0 x 4	95.9	125
	36	AP3624HT8P-E	AP3624T8P-E	3N~50 Hz	380-400-415 V	342	456	3.1 x 2	3.1 x 2	2.3 x 2		1.0 x 4	97.9	125
	38	AP3824HT8P-E	AP3824T8P-E	3N~50 Hz	380-400-415 V	342	456	3.1 x 2	3.1 x 2	3.1 x 2		1.0 x 4	100	125
	40	AP4024HT8P-E	AP4024T8P-E	3N~50 Hz	380-400-415 V	342	456	3.1 x 2	3.1 x 2	3.1 x 2		1.0 x 4	102	125
	42	AP4224HT8P-E	AP4224T8P-E	3N~50 Hz	380-400-415 V	342	456	4.2 x 2	3.1 x 2	3.1 x 2		1.0 x 4	105	125
	44	AP4424HT8P-E	AP4424T8P-E	3N~50 Hz	380-400-415 V	342	456	4.2 x 2	4.2 x 2	3.1 x 2		1.0 x 4	108	125
	46	AP4624HT8P-E	AP4624T8P-E	3N~50 Hz	380-400-415 V	342	456	4.2 x 2	4.2 x 2	4.2 x 2		1.0 x 4	111	125
	48	AP4824HT8P-E	AP4824T8P-E	3N~50 Hz	380-400-415 V	342	456	4.2 x 2	4.2 x 2	4.2 x 2		1.0 x 4	114	125

Notes MCA : Minimum Circuit Amps
MOCp : Maximum Overcurrent Protection (Amps)



4-5. Indoor unit power supply

• Electrical characteristics

Type	Model	Nominal Voltage (V-Ph-Hz)	Voltage Range		Fan Motor		Power Supply	
			Min	Max	kW	FLA	MCA	MOCP
4-Way Air Discharge Cassette Type	MMU-AP0092H	230-1-50	198	264	0.014	0.63	0.79	15
	MMU-AP0122H	230-1-50	198	264	0.014	0.63	0.79	15
	MMU-AP0152H	230-1-50	198	264	0.014	0.80	1.00	15
	MMU-AP0182H	230-1-50	198	264	0.014	0.80	1.00	15
	MMU-AP0242H	230-1-50	198	264	0.020	0.87	1.09	15
	MMU-AP0272H	230-1-50	198	264	0.020	0.87	1.09	15
	MMU-AP0302H	230-1-50	198	264	0.020	0.87	1.09	15
	MMU-AP0362H	230-1-50	198	264	0.068	1.15	1.44	15
	MMU-AP0482H	230-1-50	198	264	0.072	1.15	1.44	15
	MMU-AP0562H	230-1-50	198	264	0.072	1.15	1.44	15
	MMU-AP0094HP-E	230-1-50	198	264	0.014	0.63	0.79	15
	MMU-AP0124HP-E	230-1-50	198	264	0.014	0.63	0.79	15
	MMU-AP0154HP-E	230-1-50	198	264	0.014	0.80	1.00	15
	MMU-AP0184HP-E	230-1-50	198	264	0.014	0.80	1.00	15
	MMU-AP0244HP-E	230-1-50	198	264	0.020	0.87	1.09	15
	MMU-AP0274HP-E	230-1-50	198	264	0.020	0.87	1.09	15
	MMU-AP0304HP-E	230-1-50	198	264	0.020	0.87	1.09	15
	MMU-AP0364HP-E	230-1-50	198	264	0.068	1.15	1.44	15
MMU-AP0484HP-E	230-1-50	198	264	0.072	1.15	1.44	15	
MMU-AP0564HP-E	230-1-50	198	264	0.072	1.15	1.44	15	
Compact 4-way Cassette (600 x 600) Type	MMU-AP0054MH-E	230-1-50	198	264	0.060	0.32	0.40	15
	MMU-AP0074MH-E	230-1-50	198	264	0.060	0.32	0.40	15
	MMU-AP0094MH-E	230-1-50	198	264	0.060	0.35	0.44	15
	MMU-AP0124MH-E	230-1-50	198	264	0.060	0.36	0.45	15
	MMU-AP0154MH-E	230-1-50	198	264	0.060	0.48	0.60	15
	MMU-AP0184MH-E	230-1-50	198	264	0.060	0.48	0.60	15
2-Way Air Discharge Cassette Type	MMU-AP0072WH	230-1-50	198	264	0.020	0.32	0.40	15
	MMU-AP0092WH	230-1-50	198	264	0.020	0.32	0.40	15
	MMU-AP0122WH	230-1-50	198	264	0.020	0.32	0.40	15
	MMU-AP0152WH	230-1-50	198	264	0.020	0.32	0.40	15
	MMU-AP0182WH	230-1-50	198	264	0.030	0.70	0.88	15
	MMU-AP0242WH	230-1-50	198	264	0.040	0.81	1.01	15
	MMU-AP0272WH	230-1-50	198	264	0.040	0.81	1.01	15
	MMU-AP0302WH	230-1-50	198	264	0.050	0.81	1.01	15
	MMU-AP0362WH	230-1-50	198	264	0.070	0.87	1.09	15
MMU-AP0485WH	230-1-50	198	264	0.070	0.87	1.09	15	
MMU-AP0562WH	230-1-50	198	264	0.070	0.87	1.09	15	
1-Way Air Discharge Cassette Type	MMU-AP0074YH-E	230-1-50	198	264	0.022	0.28	0.35	15
	MMU-AP0094YH-E	230-1-50	198	264	0.022	0.28	0.35	15
	MMU-AP0124YH-E	230-1-50	198	264	0.022	0.28	0.35	15
	MMU-AP0154SH-E	230-1-50	198	264	0.030	0.40	0.49	15
	MMU-AP0184SH-E	230-1-50	198	264	0.030	0.42	0.53	15
	MMU-AP0244SH-E	230-1-50	198	264	0.030	0.71	0.88	15



Type	Model	Nominal Voltage (V-Ph-Hz)	Voltage Range		Fan Motor		Power Supply	
			Min	Max	kW	FLA	MCA	MOCP
Concealed Duct Type	MMD-AP0074BH-E	230-1-50	198	264	0.120	0.33	0.41	15
	MMD-AP0094BH-E	230-1-50	198	264	0.120	0.33	0.41	15
	MMD-AP0124BH-E	230-1-50	198	264	0.120	0.39	0.49	15
	MMD-AP0154BH-E	230-1-50	198	264	0.120	0.39	0.49	15
	MMD-AP0184BH-E	230-1-50	198	264	0.120	0.50	0.62	15
	MMD-AP0244BH-E	230-1-50	198	264	0.120	0.60	0.75	15
	MMD-AP0274BH-E	230-1-50	198	264	0.120	0.60	0.75	15
	MMD-AP0304BH-E	230-1-50	198	264	0.120	0.70	0.88	15
	MMD-AP0364BH-E	230-1-50	198	264	0.120	0.96	1.20	15
	MMD-AP0484BH-E	230-1-50	198	264	0.120	1.13	1.41	15
	MMD-AP0564BH-E	230-1-50	198	264	0.120	1.13	1.41	15
	MMD-AP0076BH-E	230-1-50	198	264	0.150	0.30	0.37	15
	MMD-AP0096BH-E	230-1-50	198	264	0.150	0.34	0.42	15
	MMD-AP0126BH-E	230-1-50	198	264	0.150	0.34	0.42	15
	MMD-AP0156BH-E	230-1-50	198	264	0.150	0.48	0.61	15
	MMD-AP0186BH-E	230-1-50	198	264	0.150	0.48	0.61	15
	MMD-AP0246BH-E	230-1-50	198	264	0.150	0.60	0.75	15
	MMD-AP0276BH-E	230-1-50	198	264	0.150	0.60	0.75	15
	MMD-AP0306BH-E	230-1-50	198	264	0.150	0.70	0.88	15
	MMD-AP0366BH-E	230-1-50	198	264	0.250	1.23	1.54	15
MMD-AP0486BH-E	230-1-50	198	264	0.250	1.41	1.77	15	
MMD-AP0566BH-E	230-1-50	198	264	0.250	1.41	1.77	15	
Concealed Duct High Static Pressure Type	MMD-AP0184H-E	230-1-50	198	264	0.160	0.93	1.16	15
	MMD-AP0244H-E	230-1-50	198	264	0.160	1.55	1.94	15
	MMD-AP0274H-E	230-1-50	198	264	0.160	1.55	1.94	15
	MMD-AP0364H-E	230-1-50	198	264	0.260	1.87	2.34	15
	MMD-AP0484H-E	230-1-50	198	264	0.260	2.12	2.65	15
	MMD-AP0724H-E	230-1-50	198	264	0.370 x 3	6.04	7.55	15
MMD-AP0964H-E	230-1-50	198	264	0.370 x 3	6.35	7.94	15	
Slim Duct Type	MMD-AP0054SPH-E	230-1-50	198	264	0.060	0.35	0.44	15
	MMD-AP0074SPH-E	230-1-50	198	264	0.060	0.35	0.44	15
	MMD-AP0094SPH-E	230-1-50	198	264	0.060	0.35	0.44	15
	MMD-AP0124SPH-E	230-1-50	198	264	0.060	0.37	0.47	15
	MMD-AP0154SPH-E	230-1-50	198	264	0.060	0.38	0.48	15
	MMD-AP0184SPH-E	230-1-50	198	264	0.060	0.47	0.59	15
	MMD-AP0244SPH-E	230-1-50	198	264	0.120	0.86	1.08	15
MMD-AP0274SPH-E	230-1-50	198	264	0.120	0.86	1.08	15	
Ceiling Type	MMC-AP0154H-E	230-1-50	198	264	0.030	0.33	0.41	15
	MMC-AP0184H-E	230-1-50	198	264	0.030	0.37	0.46	15
	MMC-AP0244H-E	230-1-50	198	264	0.040	0.48	0.60	15
	MMC-AP0274H-E	230-1-50	198	264	0.040	0.48	0.60	15
	MMC-AP0364H-E	230-1-50	198	264	0.080	0.90	1.13	15
MMC-AP0484H-E	230-1-50	198	264	0.080	0.96	1.20	15	
High-wall Type (3 series)	MMK-AP0073H	230-1-50	198	264	0.030	0.20	0.22	15
	MMK-AP0093H	230-1-50	198	264	0.030	0.22	0.24	15
	MMK-AP0123H	230-1-50	198	264	0.030	0.22	0.24	15
	MMK-AP0153H	230-1-50	198	264	0.030	0.37	0.40	15
	MMK-AP0183H	230-1-50	198	264	0.030	0.37	0.40	15
	MMK-AP0243H	230-1-50	198	264	0.030	0.43	0.47	15
High-wall Type (4 series)	MMK-AP0074MH-E	230-1-50	198	264	0.030	0.20	0.24	15
	MMK-AP0094MH-E	230-1-50	198	264	0.030	0.21	0.26	15
	MMK-AP0124MH-E	230-1-50	198	264	0.030	0.22	0.27	15
Floor Standing Cabinet Type	MML-AP0074H-E	230-1-50	198	264	0.045	0.30	0.37	15
	MML-AP0094H-E	230-1-50	198	264	0.045	0.30	0.37	15
	MML-AP0124H-E	230-1-50	198	264	0.045	0.49	0.62	15
	MML-AP0154H-E	230-1-50	198	264	0.045	0.49	0.62	15
	MML-AP0184H-E	230-1-50	198	264	0.070	0.54	0.68	15
MML-AP0244H-E	230-1-50	198	264	0.070	0.54	0.68	15	
Floor Standing Concealed Type	MML-AP0074BH-E	230-1-50	198	264	0.019	0.29	0.36	15
	MML-AP0094BH-E	230-1-50	198	264	0.019	0.29	0.36	15
	MML-AP0124BH-E	230-1-50	198	264	0.019	0.29	0.36	15
	MML-AP0154BH-E	230-1-50	198	264	0.070	0.52	0.65	15
	MML-AP0184BH-E	230-1-50	198	264	0.070	0.52	0.65	15
MML-AP0244BH-E	230-1-50	198	264	0.070	0.53	0.66	15	



Type	Model	Nominal Voltage (V-Ph-Hz)	Voltage Range		Fan Motor		Power Supply	
			Min	Max	kW	FLA	MCA	MOCP
Floor Standing Type	MMF-AP0154H-E	230-1-50	198	264	0.037	0.77	0.96	15
	MMF-AP0184H-E	230-1-50	198	264	0.037	0.77	0.96	15
	MMF-AP0244H-E	230-1-50	198	264	0.063	1.01	1.27	15
	MMF-AP0274H-E	230-1-50	198	264	0.063	1.01	1.27	15
	MMF-AP0364H-E	230-1-50	198	264	0.110	1.48	1.85	15
	MMF-AP0484H-E	230-1-50	198	264	0.160	1.84	2.30	15
Fresh Air Intake Indoor Unit Type	MMF-AP0564H-E	230-1-50	198	264	0.160	1.84	2.30	15
	MMD-AP0481HFE	230-1-50	198	264	0.160	0.28	0.35	15
	MMD-AP0721HFE	230-1-50	198	264	0.16 x 2	0.45	0.56	15
Console Type	MMD-AP0961HFE	230-1-50	198	264	0.16 x 2	0.52	0.65	15
	MML-AP0074NH-E	230-1-50	198	264	0.041	0.21	0.26	15
	MML-AP0094NH-E	230-1-50	198	264	0.041	0.21	0.26	15
	MML-AP0124NH-E	230-1-50	198	264	0.041	0.25	0.31	15
	MML-AP0154NH-E	230-1-50	198	264	0.041	0.32	0.40	15
Air to Air Heat exchanger with DX-coil Type	MML-AP0184NH-E	230-1-50	198	264	0.041	0.46	0.58	15
	MMD-VN502HEXE	230-1-50	198	264	0.248	1.5	1.7	15
	MMD-VN802HEXE	230-1-50	198	264	0.254	2.6	3.0	15
	MMD-VN1002HEXE	230-1-50	198	264	0.568	2.9	3.5	15
Air to Air Heat exchanger with DX-coil Humidifier Type	MMD-VNK502HEXE	230-1-50	198	264	0.248	1.5	1.7	15
	MMD-VNK802HEXE	230-1-50	198	264	0.254	2.6	2.9	15
	MMD-VNK1002HEXE	230-1-50	198	264	0.568	2.9	3.4	15

• **Wiring size**

Must be independent from the outdoor unit power supply

Model	Item	Power supply wiring			
		Wire size			
All models of indoor units		2.0 mm ² (AWG#14)	Max. 20 m	3.5 mm ² (AWG#12)	Max. 50 m

NOTE:

The above connecting lengths stated in the table, indicate the length from the isolator to the outdoor unit. When the power supply of the indoor units are connected in parallel, it is assumed that no more than a 2 % voltage drop will occur. If the connecting length is to exceed the stated lengths, select a suitable wire in accordance with the local wiring standards.

4-6. Design of control wiring

• Summary of control wiring

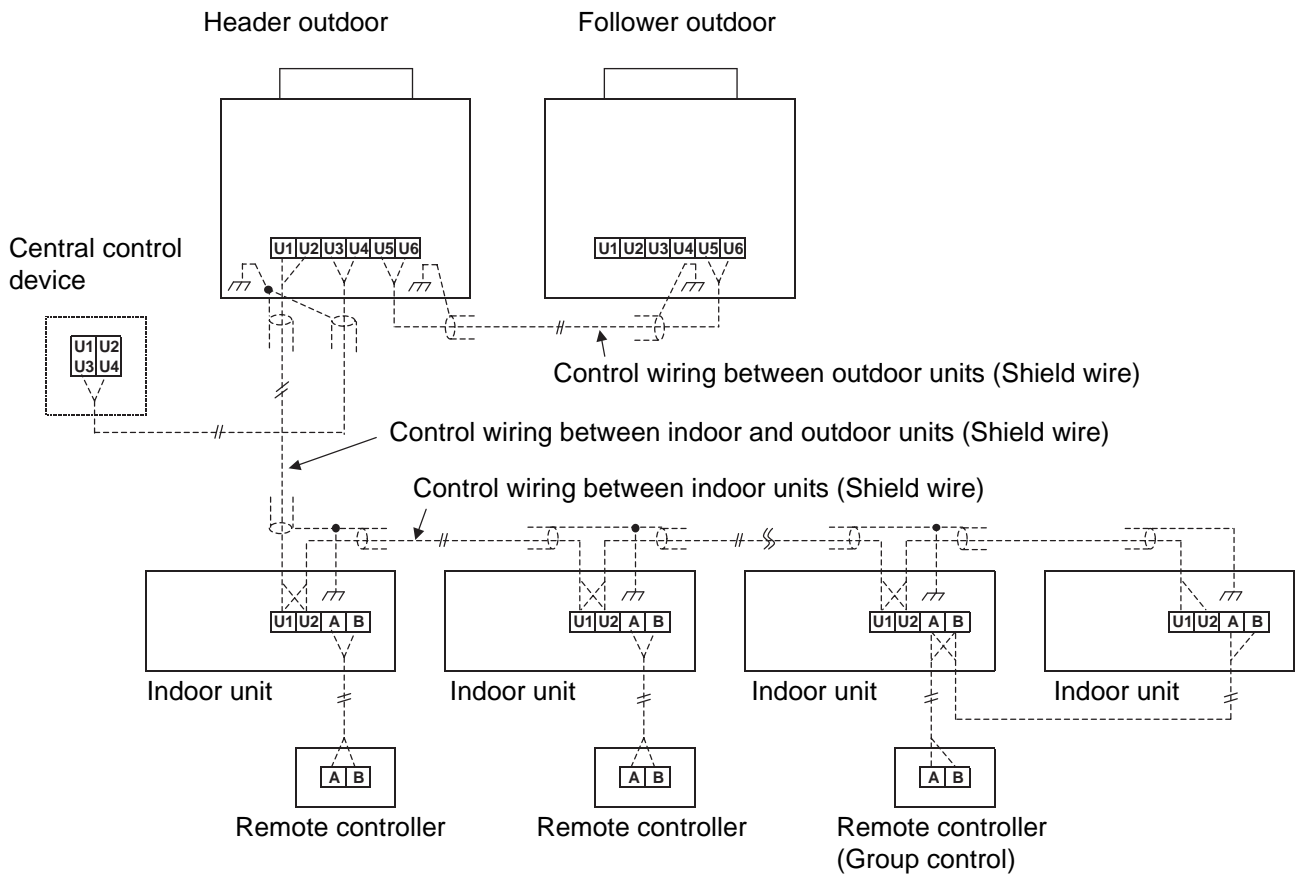



• Restriction of control wiring

Be sure to keep the rule of below tables about size and length of control wiring.

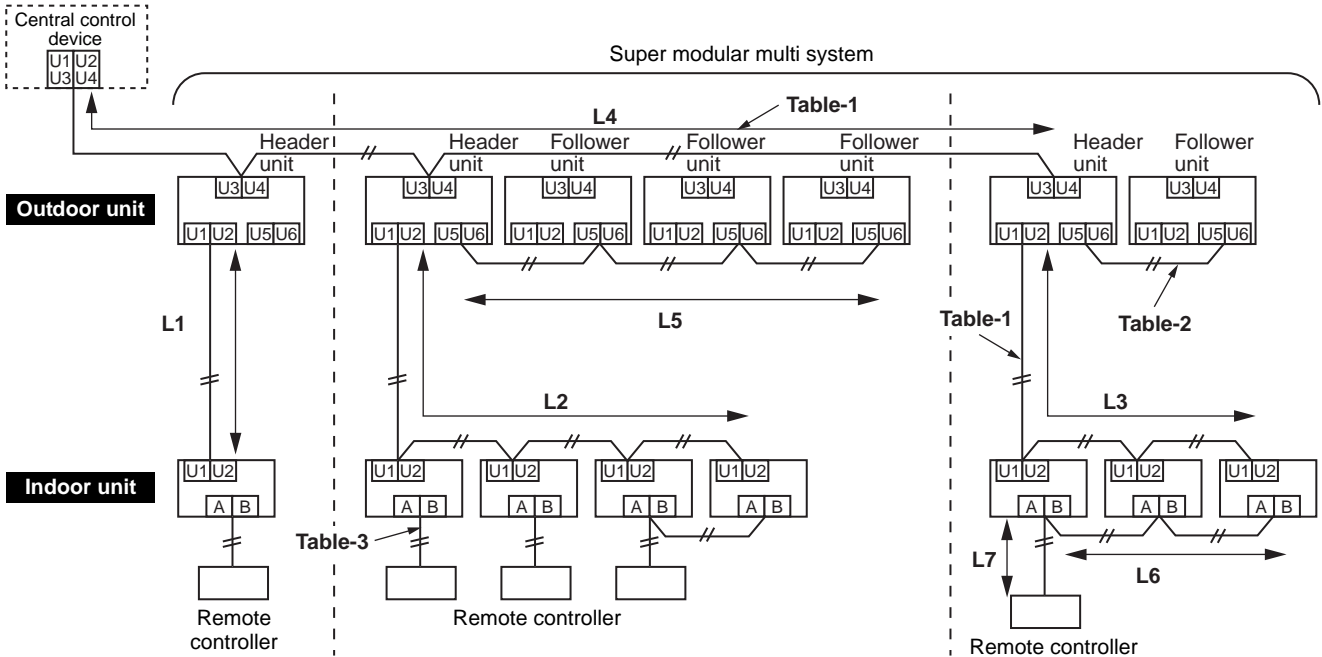

Table-1 Control wiring between indoor and outdoor units (L1, L2, L3), Central control wiring (L4)

Wiring	2-core, non-polarity
Type	Shield wire
Size/Length	1.25 mm ² : Up to 1000 m/2.0 mm ² : Up to 2000 m (*1)

Note (*1): Total length of control wiring length for all refrigerant circuits (L1 + L2 + L3 + L4)

Table-2 Control wiring between outdoor units (L5)

Wiring	2-core, non-polarity
Type	Shield wire
Size/Length	1.25 mm ² to 2.0 mm ² /Up to 100 m (L5)

Table-3 Remote controller wiring (L6, L7)

Wire	2-core
Size	0.5 mm ² to 2.0 mm ²
Length	<ul style="list-style-type: none"> • Up to 500 m (L6 + L7) • Up to 400 m in case of wireless remote controller in group control. • Up to 200 m total length of control wiring between indoor units (L6)

• Group Operation through a Remote Controller

Group operation of multiple indoor units (8 units) through a single remote controller switch

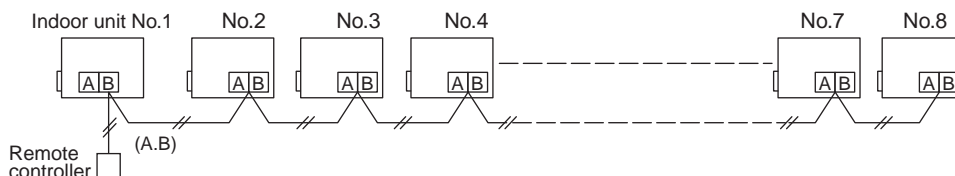



5-1. Specifications

Standard model

Model name		Heat pump	MMY-	MAP0804HT8P-E	MAP1004HT8P-E	MAP1204HT8P-E	MAP1404HT8P-E	MAP1604HT8P-E	
		Cooling only	MMY-	MAP0804T8P-E	MAP1004T8P-E	MAP1204T8P-E	MAP1404T8P-E	MAP1604T8P-E	
Outdoor unit type			Inverter unit						
Cooling capacity (*1)		kW	22.4	28.0	33.5	40.0	45.0		
Heating capacity (*1)		kW	25.0	31.5	37.5	45.0	50.0		
Capacity range		HP	8	10	12	14	16		
Power supply			3 phase 4 wires 50 Hz 380 / 400 / 415 V						
Voltage range (*2)		Minimum	V 342						
		Maximum	V 456						
Electrical characteristic (*1)	Cooling	Running current	A	8.9 / 8.5 / 8.2	12.0 / 11.4 / 11.0	15.4 / 14.7 / 14.1	18.6 / 17.7 / 17.0	21.9 / 20.8 / 20.1	
		Power input	kW	5.40	7.41	9.55	11.5	13.7	
		EER	kW/kW	4.15	3.78	3.51	3.48	3.28	
	Heating	Running current	A	9.2 / 8.8 / 8.5	12.4 / 11.8 / 11.3	16.8 / 16.0 / 15.4	18.5 / 17.6 / 16.9	23.2 / 22.0 / 21.2	
		Power input	kW	5.53	7.50	10.2	11.2	14.2	
		COP	kW/kW	4.52	4.20	3.68	4.02	3.52	
	Starting current	A	Soft start						
Dimension	Packing	Height	mm	1,887	1,887	1,887	1,887	1,887	
		Width	mm	1,062	1,062	1,062	1,282	1,282	
		Depth	mm	828	828	828	828	828	
	Unit	Height	mm	1,830	1,830	1,830	1,830	1,830	
		Width	mm	990	990	990	1,210	1,210	
		Depth	mm	780	780	780	780	780	
Weight	Packing	Heat pump	kg	257	257	257	346	346	
		Cooling only	kg	256	256	256	346	346	
	Unit	Heat pump	kg	242	242	242	329	329	
		Cooling only	kg	241	241	241	329	329	
Colour			Silky shade (Munsell 1Y8.5/0.5)						
Compressor		Type	Hermetic twin rotary compressor						
		Motor output	kW	2.3 × 2	3.1 × 2	4.2 × 2	3.0 × 3	3.6 × 3	
Fan unit		Fan	Propeller fan						
		Motor output	kW	1.0			1.0		
		Air volume	m ³ /h	9,900	10,500	11,600	12,000	13,000	
Max. external static pressure		Pa	60	60	50	40	40		
Heat exchanger			Finned tube						
Refrigerant		Name	R410A						
		Charge	Heat pump	kg	11.5				
			Cooling only	kg	10.5			11.5	
High-pressure switch		Pa	OFF:2.9 ON:3.73						
Protective devices			(*3)						
Power supply wiring		MCA (*4)	A	23.5	25.5	28.5	33.2	36.5	
		MOCP (*5)	A	32			40		50
Piping connections	Liquid	Type	Flare						
		Diameter	mm	12.7			15.9		
	Gas	Type	Brazing						
		Diameter	mm	22.2			28.6		
	Balance	Type	Flare						
		Diameter	mm	9.5					
Max. number of connected indoor units			13	16	20	23	27		
Sound pressure level		Cooling	dB(A)	55.0	57.0	59.0	60.0	62.0	
		Heating	dB(A)	56.0	58.0	62.0	62.0	64.0	
Sound power level		Cooling	dB(A)	77	78	82	82	83	
		Heating	dB(A)	78	79	83	83	84	
Operation temperature range		Cooling	CDB	-5 to 43					
		Heating	CWB	-20 to 15.5					

Note

(*1) Rated conditions Cooling : Indoor 27 degC Dry Bulb / 19 degC Wet Bulb, Outdoor 35 degC Dry Bulb.
Heating : Indoor 20 degC Dry Bulb, Outdoor 7 degC Dry Bulb / 6 degC Wet Bulb.
Based on equivalent piping length of 7.5 m and piping height difference of 0 m.

(*2) Voltage range : Units are suitable for use on electrical systems where voltage supplied to unit terminal is not below or above listed range limits.

(*3) Discharge temp. sensor / Suction temp. sensor / High-pressure sensor / Low-pressure sensor / High-pressure switch / P.C. board fuse

(*4) Select wire size base on the larger value of MCA.

MCA : Minimum Circuit Amps

(*5) MOCP : Maximum Overcurrent Protection (Amps)



Model	Name	Heat pump	MMY-	AP1814HT8P-E	AP2014HT8P-E	AP2214HT8P-E	AP2414HT8P-E	AP2614HT8P-E
		Cooling only	MMY-	AP1814T8P-E	AP2014T8P-E	AP2214T8P-E	AP2414T8P-E	AP2614T8P-E
	Combination	Heat pump	MMY-	MAP1004HT8P-E MAP0804HT8P-E	MAP1004HT8P-E MAP1004HT8P-E	MAP1204HT8P-E MAP1004HT8P-E	MAP1204HT8P-E MAP1204HT8P-E	MAP1604HT8P-E MAP1004HT8P-E
		Cooling only	MMY-	MAP1004T8P-E MAP0804T8P-E	MAP1004T8P-E MAP1004T8P-E	MAP1204T8P-E MAP1004T8P-E	MAP1204T8P-E MAP1204T8P-E	MAP1604T8P-E MAP1004T8P-E
Outdoor unit type				Inverter unit				
Cooling capacity (*1)			kW	50.4	56.0	61.5	68.0	73.0
Heating capacity (*1)			kW	56.5	63.0	69.0	76.5	81.5
Capacity range			HP	18	20	22	24	26
Power supply				3 phase 4 wires 50 Hz 380 / 400 / 415 V				
Voltage range (*2)		Minimum	V	342				
		Maximum	V	456				
Electrical characteristic (*1)	Cooling	Running current	A	20.9 / 19.9 / 19.1	24.0 / 22.8 / 21.9	27.4 / 26.0 / 25.1	31.8 / 30.2 / 29.1	33.9 / 32.2 / 31.0
		Power input	kW	12.81	14.82	16.96	19.66	21.11
		EER	kW/kW	3.93	3.78	3.63	3.46	3.46
	Heating	Running current	A	21.6 / 20.5 / 19.8	24.8 / 23.5 / 22.7	29.2 / 27.8 / 26.8	34.9 / 33.2 / 32.0	35.6 / 33.8 / 32.6
		Power input	kW	13.03	15.0	17.7	21.13	21.7
		COP	kW/kW	4.34	4.2	3.9	3.62	3.76
	Starting current		A	Soft start				
Weight	Heat pump	kg	242 + 242	242 + 242	242 + 242	242 + 242	329 + 242	
	Cooling only	kg	241 + 241	241 + 241	241 + 241	241 + 241	329 + 241	
Colour				Silky shade (Munsell 1Y8.5/0.5)				
Compressor	Type			Hermetic twin rotary compressor				
	Motor output	kW	3.1 x 2 + 2.3 x 2	3.1 x 2 + 3.1 x 2	4.2 x 2 + 3.1 x 2	4.2 x 2 + 4.2 x 2	3.6 x 3 + 3.1 x 2	
Fan unit	Fan			Propeller fan				
	Motor output	kW	1.0 + 1.0	1.0 + 1.0	1.0 + 1.0	1.0 + 1.0	1.0 + 1.0	
	Air volume	m³/h	10,500 + 9,900	10,500 + 10,500	11,600 + 10,500	11,600 + 11,600	13,000 + 10,500	
Max. external static pressure			Pa	60	60	50	50	40
Heat exchanger				Finned tube				
Refrigerant	Name			R410A				
	Charge	Heat pump	kg	11.5 + 11.5	11.5 + 11.5	11.5 + 11.5	11.5 + 11.5	11.5 + 11.5
		Cooling only	kg	10.5 + 10.5	10.5 + 10.5	10.5 + 10.5	10.5 + 10.5	10.5 + 10.5
High-pressure switch			Pa	OFF:2.9 ON:3.73				
Protective devices				(*3)				
Power supply wiring		MCA (*4)	A	49.0	51.0	54.0	57.0	62.0
		MOCP (*5)	A	63	63	63	63	80
Piping connections	Liquid	Type	Flare					
		Diameter	mm	15.9		19.1		
	Gas	Type	Brazeing					
		Diameter	mm	28.6		34.9		
	Balance	Type	Flare					
		Diameter	mm	9.5				
Max. number of connected indoor units				30	33	37	40	43
Sound pressure level		Cooling	dB(A)	59.5	60.0	61.5	62.0	63.5
		Heating	dB(A)	60.5	61.0	63.5	65.0	65.0
Operation temperature range		Cooling	CDB	-5 to 43				
		Heating	CWB	-20 to 15.5				

Note

(*1) Rated conditions Cooling : Indoor 27 degC Dry Bulb / 19 degC Wet Bulb, Outdoor 35 degC Dry Bulb.
Heating : Indoor 20 degC Dry Bulb, Outdoor 7 degC Dry Bulb / 6 degC Wet Bulb.
Based on equivalent piping length of 7.5 m and piping height difference of 0 m.

(*2) Voltage range : Units are suitable for use on electrical systems where voltage supplied to unit terminal is not below or above listed range limits.

(*3) Discharge temp. sensor / Suction temp. sensor / High-pressure sensor / Low-pressure sensor / High-pressure switch / P.C. board fuse

(*4) Select wire size base on the larger value of MCA.

MCA : Minimum Circuit Amps

(*5) MOCP : Maximum Overcurrent Protection (Amps)



Model	Name	Heat pump	MMY-	AP2814HT8P-E	AP3014HT8P-E	AP3214HT8P-E	AP3414HT8P-E	AP3614HT8P-E		
	Combination	Cooling only	MMY-	AP2814T8P-E	AP3014T8P-E	AP3214T8P-E	AP3414T8P-E	AP3614T8P-E		
Model	Combination	Heat pump	MMY-	AP1604HT8P-E AP1204HT8P-E	MAP1604HT8P-E MAP1404HT8P-E	MAP1604HT8P-E MAP1604HT8P-E	MAP1204HT8P-E MAP1204HT8P-E MAP1004HT8P-E	MAP1204HT8P-E MAP1204HT8P-E MAP1204HT8P-E		
		Cooling only	MMY-	MAP1604T8P-E MAP1204T8P-E	MAP1604T8P-E MAP1404T8P-E	MAP1604T8P-E MAP1604T8P-E	MAP1204T8P-E MAP1204T8P-E MAP1004T8P-E	MAP1204T8P-E MAP1204T8P-E MAP1204T8P-E		
Outdoor unit type				Inverter unit						
Cooling capacity (*1)			kW	78.5	85.0	90.0	96.0	101.0		
Heating capacity (*1)			kW	88.0	95.0	100.0	108.0	113.0		
Capacity range			HP	28	30	32	34	36		
Power supply				3 phase 4 wires 50 Hz 380 / 400 / 415 V						
Voltage range (*2)			Minimum	V 342						
			Maximum	V 456						
Electrical characteristic (*1)	Cooling	Running current	A	37.3 / 35.5 / 34.2	40.5 / 38.5 / 37.1	43.8 / 41.6 / 40.1	43.7 / 41.5 / 40.0	46.8 / 44.4 / 42.8		
		Power input	kW	23.25	25.20	27.40	27.06	28.93		
		EER	kW/kW	3.38	3.37	3.28	3.55	3.49		
	Heating	Running current	A	40.4 / 38.4 / 37.0	41.7 / 39.6 / 38.2	46.4 / 44.1 / 42.5	47.2 / 44.9 / 43.2	50.9 / 48.4 / 46.6		
		Power input	kW	24.65	25.40	28.40	28.60	30.84		
		COP	kW/kW	3.57	3.74	3.52	3.78	3.66		
Starting current			A	Soft start						
Weight	Heat pump	kg	329 + 242	329 + 329	329 + 329	242 + 242 + 242	242 + 242 + 242			
	Cooling only	kg	329 + 241	329 + 329	329 + 329	241 + 241 + 241	241 + 241 + 241			
Colour				Silky shade (Munsell 1Y8.5/0.5)						
Compressor	Type			Hermetic twin rotary compressor						
	Motor output			kW	3.6 × 3 + 4.2 × 2	3.6 × 3 + 3.0 × 3	3.6 × 3 + 3.6 × 3	4.2 × 2 + 4.2 × 2 + 3.1 × 2	4.2 × 2 + 4.2 × 2 + 4.2 × 2	
Fan unit	Fan			Propeller fan						
	Motor output			kW	1.0 + 1.0	1.0 + 1.0	1.0 + 1.0	1.0 + 1.0 + 1.0	1.0 + 1.0 + 1.0	
	Air volume			m ³ /h	13,000 + 11,600	13,000 + 12,000	13,000 + 13,000	11,600 + 11,600 + 10,500	11,600 + 11,600 + 11,600	
Max. external static pressure			Pa	40	40	40	60	50		
Heat exchanger				Finned tube						
Refrigerant	Name			R410A						
	Charge	Heat pump	kg	11.5 + 11.5	11.5 + 11.5	11.5 + 11.5	11.5 + 11.5 + 11.5	11.5 + 11.5 + 11.5		
		Cooling only	kg	11.5 + 10.5	11.5 + 11.5	11.5 + 11.5	10.5 + 10.5 + 10.5	10.5 + 10.5 + 10.5		
High-pressure switch			Pa	OFF:2.9 ON:3.73						
Protective devices				(*3)						
Power supply wiring			MCA (*4)	A	65.0	69.7	73.0	82.5	85.5	
			MOCP (*5)	A	80	80	100	100	100	
Piping connections	Liquid	Type			Flare					
		Diameter			mm	19.1				
	Gas	Type			Brazing					
		Diameter			mm	34.9				
	Balance	Type			Brazing					
		Diameter			mm	9.5				
Max. number of connected indoor units				47	48	48	48	48		
Sound pressure level			Cooling	dB(A)	64.0	64.5	65.0	63.5	64.0	
			Heating	dB(A)	65.0	66.5	67.0	66.0	67.0	
Operation temperature range			Cooling	CDB	-5 to 43					
			Heating	CWB	-20 to 15.5					

Note
 (*1) Rated conditions Cooling : Indoor 27 degC Dry Bulb / 19 degC Wet Bulb, Outdoor 35 degC Dry Bulb.
 Heating : Indoor 20 degC Dry Bulb, Outdoor 7 degC Dry Bulb / 6 degC Wet Bulb.
 Based on equivalent piping length of 7.5 m and piping height difference of 0 m.
 (*2) Voltage range : Units are suitable for use on electrical systems where voltage supplied to unit terminal is not below or above listed range limits.
 (*3) Discharge temp. sensor / Suction temp. sensor / High-pressure sensor / Low-pressure sensor / High-pressure switch / P.C. board fuse
 (*4) Select wire size base on the larger value of MCA.
 MCA : Minimum Circuit Amps
 (*5) MOCP : Maximum Overcurrent Protection (Amps)



Model	Name		Heat pump	MMY-	AP3814HT8P-E	AP4014HT8P-E	AP4214HT8P-E	AP4414HT8P-E	AP4614HT8P-E	AP4814HT8P-E	
	Cooling only		MMY-	AP3814T8P-E	AP4014T8P-E	AP4214T8P-E	AP4414T8P-E	AP4614T8P-E	AP4814T8P-E		
Model	Combination		Heat pump	MMY-	MAP1604HT8P-E MAP1204HT8P-E MAP1004HT8P-E	MAP1604HT8P-E MAP1204HT8P-E MAP1204HT8P-E	MAP1604HT8P-E MAP1404HT8P-E MAP1204HT8P-E	MAP1604HT8P-E MAP1604HT8P-E MAP1204HT8P-E	MAP1604HT8P-E MAP1604HT8P-E MAP1404HT8P-E	MAP1604HT8P-E MAP1604HT8P-E MAP1604HT8P-E	
	Cooling only		MMY-	MAP1604T8P-E MAP1204T8P-E MAP1004T8P-E	MAP1604T8P-E MAP1204T8P-E MAP1204T8P-E	MAP1604T8P-E MAP1404T8P-E MAP1204T8P-E	MAP1604T8P-E MAP1604T8P-E MAP1204T8P-E	MAP1604T8P-E MAP1604T8P-E MAP1404T8P-E	MAP1604T8P-E MAP1604T8P-E MAP1404T8P-E		
Outdoor unit type				Inverter unit							
Cooling capacity (*1)			kW	106.0	112.0	118.0	123.5	130.0	135.0		
Heating capacity (*1)			kW	119.5	127.0	132.0	138.0	145.0	150.0		
Capacity range			HP	38	40	42	44	46	48		
Power supply				3 phase 4 wires 50 Hz 380 / 400 / 415 V							
Voltage range (*2)			Minimum	V	342						
			Maximum	V	456						
Electrical characteristic (*1)	Cooling	Running current	A	49.3 / 46.9 / 45.2	52.8 / 50.1 / 48.3	56.0 / 53.1 / 51.2	59.3 / 56.3 / 54.3	62.4 / 59.3 / 57.1	65.7 / 62.4 / 60.2		
		Power input	kW	30.66	32.80	34.47	36.95	38.90	41.10		
		EER	kW/kW	3.47	3.41	3.42	3.34	3.34	3.28		
	Heating	Running current	A	52.8 / 50.2 / 48.4	58.0 / 55.1 / 53.1	58.3 / 55.4 / 53.4	63.7 / 60.5 / 58.3	64.9 / 61.7 / 59.4	69.6 / 66.1 / 63.7		
		Power input	kW	32.14	35.29	35.46	38.85	39.60	42.60		
		COP	kW/kW	3.72	3.60	3.72	3.55	3.66	3.52		
Starting current			A	Soft start							
Weight	Heat pump		kg	329 + 242 + 242	329 + 242 + 242	329 + 329 + 242	329 + 329 + 242	329 + 329 + 329	329 + 329 + 329		
	Cooling only		kg	329 + 241 + 241	329 + 241 + 241	329 + 329 + 241	329 + 329 + 241	329 + 329 + 329	329 + 329 + 329		
Colour				Silky shade (Munsell 1Y8.5/0.5)							
Compressor	Type			Hermetic twin rotary compressor							
	Motor output		kW	3.6 × 3 + 4.2 × 2 + 3.1 × 2	3.6 × 3 + 4.2 × 2 + 4.2 × 2	3.6 × 3 + 3.0 × 3 + 4.2 × 2	3.6 × 3 + 3.6 × 3 + 4.2 × 2	3.6 × 3 + 3.6 × 3 + 3.0 × 3	3.6 × 3 + 3.6 × 3 + 3.6 × 3		
Fan unit	Fan			Propeller fan							
	Motor output		kW	1.0 + 1.0 + 1.0	1.0 + 1.0 + 1.0	1.0 + 1.0 + 1.0	1.0 + 1.0 + 1.0	1.0 + 1.0 + 1.0	1.0 + 1.0 + 1.0		
	Air volume		m ³ /h	13,000 + 11,600 + 10,500	13,000 + 11,600 + 11,600	13,000 + 12,000 + 11,600	13,000 + 13,000 + 11,600	13,000 + 13,000 + 12,000	13,000 + 13,000 + 13,000		
Max. external static pressure			Pa	40	40	40	40	40	40		
Heat exchanger				Finned tube							
Refrigerant	Name			R410A							
	Charge	Heat pump	kg	11.5 + 11.5 + 11.5	11.5 + 11.5 + 11.5	11.5 + 11.5 + 11.5	11.5 + 11.5 + 11.5	11.5 + 11.5 + 11.5	11.5 + 11.5 + 11.5		
		Cooling only	kg	11.5 + 10.5 + 10.5	11.5 + 10.5 + 10.5	11.5 + 11.5 + 10.5	11.5 + 11.5 + 10.5	11.5 + 11.5 + 11.5	11.5 + 11.5 + 11.5		
High-pressure switch			Pa	OFF:2.9 ON:3.73							
Protective devices				(*3)							
Power supply wiring			MCA (*4)	A	90.5	93.5	98.2	101.5	106.2	109.5	
			MOCP (*5)	A	100	125	125	125	125	125	
Piping connections	Liquid	Type			Flare						
		Diameter		mm	22.2						
	Gas	Type			Brazing						
		Diameter		mm	41.3						
	Balance	Type			Brazing						
		Diameter		mm	9.5						
Max. number of connected indoor units				48	48	48	48	48	48		
Sound pressure level			Cooling	dB(A)	65.0	65.0	65.5	66.0	66.5	67.0	
			Heating	dB(A)	67.0	67.5	67.5	68.5	68.5	69.0	
Operation temperature range			Cooling	CDB	-5 to 43						
			Heating	CWB	-20 to 15.5						

Note
 (*1) Rated conditions Cooling : Indoor 27 degC Dry Bulb / 19 degC Wet Bulb, Outdoor 35 degC Dry Bulb.
 Heating : Indoor 20 degC Dry Bulb, Outdoor 7 degC Dry Bulb / 6 degC Wet Bulb.
 Based on equivalent piping length of 7.5 m and piping height difference of 0 m.
 (*2) Voltage range : Units are suitable for use on electrical systems where voltage supplied to unit terminal is not below or above listed range limits.
 (*3) Discharge temp. sensor / Suction temp. sensor / High-pressure sensor / Low-pressure sensor / High-pressure switch / P.C. board fuse
 (*4) Select wire size base on the larger value of MCA.
 MCA : Minimum Circuit Amps
 (*5) MOCP : Maximum Overcurrent Protection (Amps)



High efficiency model

Model	Name		Heat pump	MMY-	AP1624HT8P-E	AP2424HT8P-E	AP2624HT8P-E	AP2824HT8P-E	AP3024HT8P-E
	Cooling only		MMY-		AP1624T8P-E	AP2424T8P-E	AP2624T8P-E	AP2824T8P-E	AP3024T8P-E
	Combination	Heat pump	MMY-	MAP0804HT8P-E MAP0804HT8P-E	MAP0804HT8P-E MAP0804HT8P-E	MAP1004HT8P-E MAP0804HT8P-E MAP0804HT8P-E	MAP1004HT8P-E MAP0804HT8P-E MAP0804HT8P-E	MAP1004HT8P-E MAP0804HT8P-E MAP0804HT8P-E	MAP1004HT8P-E MAP1004HT8P-E MAP1004HT8P-E
		Cooling only	MMY-	MAP0804T8P-E MAP0804T8P-E	MAP0804T8P-E MAP0804T8P-E	MAP1004T8P-E MAP0804T8P-E MAP0804T8P-E	MAP1004T8P-E MAP0804T8P-E MAP0804T8P-E	MAP1004T8P-E MAP1004T8P-E MAP0804T8P-E	MAP1004T8P-E MAP1004T8P-E MAP1004T8P-E
Outdoor unit type				Inverter unit					
Cooling capacity (*1)			kW	45.0	68.0	73.0	78.5	85.0	
Heating capacity (*1)			kW	50.0	76.5	81.5	88.0	95.0	
Capacity range			HP	16	24	26	28	30	
Power supply				3 phase 4 wires 50 Hz 380 / 400 / 415 V					
Voltage range (*2)			Minimum	V	342				
			Maximum	V	456				
Electrical characteristic (*1)	Cooling	Running current	A	18.0 / 17.1 / 16.5	27.4 / 26.0 / 25.1	30.0 / 28.5 / 27.4	32.9 / 31.3 / 30.2	36.8 / 34.9 / 33.7	
		Power input	kW	10.89	16.58	18.31	20.27	22.75	
		EER	kW/kW	4.13	4.10	3.99	3.87	3.74	
	Heating	Running current	A	18.5 / 17.5 / 16.9	28.7 / 27.3 / 26.3	30.9 / 29.3 / 28.3	34.0 / 32.3 / 31.1	37.5 / 35.6 / 34.3	
		Power input	kW	11.06	17.18	18.56	20.53	22.71	
		COP	kW/kW	4.52	4.45	4.39	4.29	4.18	
Starting current			A	Soft start					
Weight	Heat pump	kg	242 + 242	242 + 242 + 242	242 + 242 + 242	242 + 242 + 242	242 + 242 + 242		
	Cooling only	kg	241 + 241	241 + 241 + 241	241 + 241 + 241	241 + 241 + 241	241 + 241 + 241		
Colour				Silky shade (Munsell 1Y8.5/0.5)					
Compressor	Type			Hermetic twin rotary compressor					
	Motor output		kW	2.3 x 2 + 2.3 x 2	2.3 x 2 + 2.3 x 2 + 2.3 x 2	3.1 x 2 + 2.3 x 2 + 2.3 x 2	3.1 x 2 + 3.1 x 2 + 2.3 x 2	3.1 x 2 + 3.1 x 2 + 3.1 x 2	
Fan unit	Fan			Propeller fan					
	Motor output		kW	1.0 + 1.0	1.0 + 1.0 + 1.0	1.0 + 1.0 + 1.0	1.0 + 1.0 + 1.0	1.0 + 1.0 + 1.0	
	Air volume		m³/h	9,900 + 9,900	9,900 + 9,900 + 9,900	10,500 + 9,900 + 9,900	10,500 + 10,500 + 9,900	10,500 + 10,500 + 10,500	
Max. external static pressure			Pa	60	60	60	60	60	
Heat exchanger				Finned tube					
Refrigerant	Name			R410A					
	Charge	Heat pump	kg	11.5 + 11.5	11.5 + 11.5 + 11.5	11.5 + 11.5 + 11.5	11.5 + 11.5 + 11.5	11.5 + 11.5 + 11.5	
		Cooling only	kg	10.5 + 10.5	10.5 + 10.5 + 10.5	10.5 + 10.5 + 10.5	10.5 + 10.5 + 10.5	10.5 + 10.5 + 10.5	
High-pressure switch			Pa	OFF:2.9 ON:3.73					
Protective devices				(*3)					
Power supply wiring			MCA (*4)	A	46.9	70.4	72.4	74.5	76.5
			MOCP (*5)	A	63	80	80	100	100
Piping connections	Liquid	Type			Flare				
		Diameter		mm	15.9	19.1			
	Gas	Type			Brazing				
		Diameter		mm	28.6	34.9			
	Balance	Type			Flare				
		Diameter		mm	9.5				
Max. number of connected indoor units				27	40	43	47	48	
Sound pressure level			Cooling	dB(A)	58.0	60.0	60.5	61.5	62.0
			Heating	dB(A)	59.0	61.0	61.5	62.5	63.0
Operation temperature range			Cooling	CDB	-5 to 43				
			Heating	CWB	-20 to 15.5				

Note
 (*1) Rated conditions Cooling : Indoor 27 degC Dry Bulb / 19 degC Wet Bulb, Outdoor 35 degC Dry Bulb.
 Heating : Indoor 20 degC Dry Bulb, Outdoor 7 degC Dry Bulb / 6 degC Wet Bulb.
 Based on equivalent piping length of 7.5 m and piping height difference of 0 m.
 (*2) Voltage range : Units are suitable for use on electrical systems where voltage supplied to unit terminal is not below or above listed range limits.
 (*3) Discharge temp. sensor / Suction temp. sensor / High-pressure sensor / Low-pressure sensor / High-pressure switch / P.C. board fuse
 (*4) Select wire size base on the larger value of MCA.
 MCA : Minimum Circuit Amps
 (*5) MOCP : Maximum Overcurrent Protection (Amps)



Model	Name	Heat pump	MMY-	AP3224HT8P-E	AP3424HT8P-E	AP3624HT8P-E	AP3824HT8P-E	AP4024HT8P-E	
		Cooling only	MMY-	AP3224T8P-E	AP3424T8P-E	AP3624T8P-E	AP3824T8P-E	AP4024T8P-E	
	Combination	Heat pump	MMY-	MAP0804HT8P-E MAP0804HT8P-E MAP0804HT8P-E MAP0804HT8P-E	MAP1004HT8P-E MAP0804HT8P-E MAP0804HT8P-E MAP0804HT8P-E	MAP1004HT8P-E MAP1004HT8P-E MAP0804HT8P-E MAP0804HT8P-E	MAP1004HT8P-E MAP1004HT8P-E MAP1004HT8P-E MAP0804HT8P-E	MAP1004HT8P-E MAP1004HT8P-E MAP1004HT8P-E MAP1004HT8P-E	
		Cooling only	MMY-	MAP0804T8P-E MAP0804T8P-E MAP0804T8P-E MAP0804T8P-E	MAP1004T8P-E MAP0804T8P-E MAP0804T8P-E MAP0804T8P-E	MAP1004T8P-E MAP1004T8P-E MAP0804T8P-E MAP0804T8P-E	MAP1004T8P-E MAP1004T8P-E MAP1004T8P-E MAP0804T8P-E	MAP1004T8P-E MAP1004T8P-E MAP1004T8P-E MAP1004T8P-E	
Outdoor unit type				Inverter unit					
Cooling capacity (*1)			kW	90.0	96.0	101.0	106.5	112.0	
Heating capacity (*1)			kW	100.0	108.0	113.0	119.5	127.0	
Capacity range			HP	32	34	36	38	40	
Power supply				3 phase 4 wires 50 Hz 380 / 400 / 415 V					
Voltage range (*2)		Minimum	V	342					
		Maximum	V	456					
Electrical characteristic (*1)	Cooling	Running current	A	36.0 / 34.2 / 33.0	39.4 / 37.4 / 36.1	42.0 / 39.9 / 38.4	44.9 / 42.7 / 41.1	47.9 / 45.5 / 43.9	
		Power input	kW	21.79	24.00	25.72	27.68	29.64	
		EER	kW/kW	4.13	4.00	3.93	3.85	3.78	
	Heating	Running current	A	36.9 / 35.1 / 33.8	41.1 / 39.0 / 37.6	43.2 / 41.1 / 39.6	46.4 / 44.1 / 42.5	50.2 / 44.7 / 46.0	
		Power input	kW	22.12	24.70	26.06	28.03	30.42	
		COP	kW/kW	4.52	4.37	4.34	4.26	4.17	
	Starting current		A	Soft start					
Weight	Heat pump	kg	242 + 242 + 242 + 242	242 + 242 + 242 + 242	242 + 242 + 242 + 242	242 + 242 + 242 + 242	242 + 242 + 242 + 242		
	Cooling only	kg	241 + 241 + 241 + 241	241 + 241 + 241 + 241	241 + 241 + 241 + 241	241 + 241 + 241 + 241	241 + 241 + 241 + 241		
Colour				Silky shade (Munsell 1Y8.5/0.5)					
Compressor	Type	Hermetic twin rotary compressor							
	Motor output	kW	2.3 × 2 + 2.3 × 2 + 2.3 × 2	3.1 × 2 + 2.3 × 2 + 2.3 × 2	3.1 × 2 + 3.1 × 2 + 2.3 × 2 + 2.3 × 2	3.1 × 2 + 3.1 × 2 + 3.1 × 2 + 2.3 × 2	3.1 × 2 + 3.1 × 2 + 3.1 × 2 + 2.3 × 2	3.1 × 2 + 3.1 × 2 + 3.1 × 2 + 2.3 × 2	
Fan unit	Fan	Propeller fan							
	Motor output	kW	1.0 + 1.0 + 1.0 + 1.0	1.0 + 1.0 + 1.0 + 1.0	1.0 + 1.0 + 1.0 + 1.0	1.0 + 1.0 + 1.0 + 1.0	1.0 + 1.0 + 1.0 + 1.0		
	Air volume	m ³ /h	9,900 + 9,900 + 9,900 + 9,900	10,500 + 9,900 + 9,900 + 9,900	10,500 + 10,500 + 9,900 + 9,900	10,500 + 10,500 + 10,500 + 9,900	10,500 + 10,500 + 10,500 + 10,500		
Max. external static pressure			Pa	60	60	60	60	60	
Heat exchanger				Finned tube					
Refrigerant	Name		R410A						
	Charge	Heat pump	kg	11.5 + 11.5 + 11.5 + 11.5	11.5 + 11.5 + 11.5 + 11.5	11.5 + 11.5 + 11.5 + 11.5	11.5 + 11.5 + 11.5 + 11.5	11.5 + 11.5 + 11.5 + 11.5	
		Cooling only	kg	10.5 + 10.5 + 10.5 + 10.5	10.5 + 10.5 + 10.5 + 10.5	10.5 + 10.5 + 10.5 + 10.5	10.5 + 10.5 + 10.5 + 10.5	10.5 + 10.5 + 10.5 + 10.5	
High-pressure switch			Pa	OFF:2.9 ON:3.73					
Protective devices				(*3)					
Power supply wiring		MCA (*4)	A	93.8	95.9	97.9	100.0	102.0	
		MOCP (*5)	A	125	125	125	125	125	
Piping connections	Liquid	Type	Flare						
		Diameter	mm	19.1			22.2		
	Gas	Type	Brazeing						
		Diameter	mm	34.9			41.3		
	Balance	Type	Flare						
		Diameter	mm	9.5					
Max. number of connected indoor units				48	48	48	48	48	
Sound pressure level	Cooling	dB(A)	61.0	62.0	62.5	63.0	63.0		
	Heating	dB(A)	62.0	63.0	63.5	64.0	64.0		
Operation temperature range	Cooling	CDB	-5 to 43						
	Heating	CWB	-20 to 15.5						

Note
 (*1) Rated conditions Cooling : Indoor 27 degC Dry Bulb / 19 degC Wet Bulb, Outdoor 35 degC Dry Bulb.
 Heating : Indoor 20 degC Dry Bulb, Outdoor 7 degC Dry Bulb / 6 degC Wet Bulb.
 Based on equivalent piping length of 7.5 m and piping height difference of 0 m.
 (*2) Voltage range : Units are suitable for use on electrical systems where voltage supplied to unit terminal is not below or above listed range limits.
 (*3) Discharge temp. sensor / Suction temp. sensor / High-pressure sensor / Low-pressure sensor / High-pressure switch / P.C. board fuse
 (*4) Select wire size base on the larger value of MCA.
 MCA : Minimum Circuit Amps
 (*5) MOCP : Maximum Overcurrent Protection (Amps)



Model	Name	Heat pump	MMY-	AP4224HT8P-E	AP4424HT8P-E	AP4624HT8P-E	AP4824HT8P-E
		Cooling only	MMY-	AP4224T8P-E	AP4424T8P-E	AP4624T8P-E	AP4824T8P-E
	Combination	Heat pump	MMY-	MAP1204HT8P-E MAP1004HT8P-E MAP1004HT8P-E MAP1004HT8P-E	MAP1204HT8P-E MAP1204HT8P-E MAP1004HT8P-E MAP1004HT8P-E	MAP1204HT8P-E MAP1204HT8P-E MAP1204HT8P-E MAP1004HT8P-E	MAP1204HT8P-E MAP1204HT8P-E MAP1204HT8P-E MAP1204HT8P-E
		Cooling only	MMY-	MAP1204T8P-E MAP1004T8P-E MAP1004T8P-E MAP1004T8P-E	MAP1204T8P-E MAP1204T8P-E MAP1004T8P-E MAP1004T8P-E	MAP1204T8P-E MAP1204T8P-E MAP1204T8P-E MAP1004T8P-E	MAP1204T8P-E MAP1204T8P-E MAP1204T8P-E MAP1204T8P-E
Outdoor unit type				Inverter unit			
Cooling capacity (*1)		kW	118.0	123.5	130.0	135.0	
Heating capacity (*1)		kW	132.0	138.0	145.0	150.0	
Capacity range		HP	42	44	46	48	
Power supply		3 phase 4 wires 50 Hz 380 / 400 / 415 V					
Voltage range (*2)		Minimum	V	342			
		Maximum	V	456			
Electrical characteristic (*1)	Cooling	Running current	A	51.8 / 49.2 / 47.4	55.3 / 52.5 / 50.6	59.6 / 56.6 / 54.6	62.6 / 59.5 / 57.4
		Power input	kW	32.04	34.19	36.88	38.76
		EER	kW/kW	3.68	3.61	3.52	3.48
	Heating	Running current	A	54.0 / 51.3 / 49.4	58.5 / 55.5 / 53.5	63.7 / 60.5 / 58.3	67.4 / 64.0 / 61.7
		Power input	kW	32.70	35.40	38.57	40.80
		COP	kW/kW	4.04	3.90	3.76	3.68
	Starting current		A	Soft start			
Weight	Heat pump	kg	242 + 242 + 242 + 242	242 + 242 + 242 + 242	242 + 242 + 242 + 242	242 + 242 + 242 + 242	
	Cooling only	kg	241 + 241 + 241 + 241	241 + 241 + 241 + 241	241 + 241 + 241 + 241	241 + 241 + 241 + 241	
Colour		Silky shade (Munsell 1Y8.5/0.5)					
Compressor	Type	Hermetic twin rotary compressor					
	Motor output	kW	4.2 × 2 + 3.1 × 2 + 3.1 × 2 + 3.1 × 2	4.2 × 2 + 4.2 × 2 + 3.1 × 2 + 3.1 × 2	4.2 × 2 + 4.2 × 2 + 4.2 × 2 + 3.1 × 2	4.2 × 2 + 4.2 × 2 + 4.2 × 2 + 4.2 × 2	
Fan unit	Fan	Propeller fan					
	Motor output	kW	1.0 + 1.0 + 1.0 + 1.0	1.0 + 1.0 + 1.0 + 1.0	1.0 + 1.0 + 1.0 + 1.0	1.0 + 1.0 + 1.0 + 1.0	
	Air volume	m ³ /h	11,600 + 10,500 + 10,500 + 10,500	11,600 + 11,600 + 10,500 + 10,500	11,600 + 11,600 + 11,600 + 10,500	11,600 + 11,600 + 11,600 + 11,600	
Max. external static pressure		Pa	50	50	50	50	
Heat exchanger		Finned tube					
Refrigerant	Name	R410A					
	Charge	Heat pump	kg	11.5 + 11.5 + 11.5 + 11.5	11.5 + 11.5 + 11.5 + 11.5	11.5 + 11.5 + 11.5 + 11.5	11.5 + 11.5 + 11.5 + 11.5
		Cooling only	kg	10.5 + 10.5 + 10.5 + 10.5	10.5 + 10.5 + 10.5 + 10.5	10.5 + 10.5 + 10.5 + 10.5	10.5 + 10.5 + 10.5 + 10.5
High-pressure switch		Pa	OFF:2.9 ON:3.73				
Protective devices		(*3)					
Power supply wiring	MCA (*4)	A	105.0	108.0	111.0	114.0	
	MOCP (*5)	A	125	125	125	125	
Piping connections	Liquid	Type	Flare				
		Diameter	mm	22.2			
	Gas	Type	Brazing				
		Diameter	mm	41.3			
	Balance	Type	Flare				
		Diameter	mm	9.5			
Max. number of connected indoor units			48	48	48	48	
Sound pressure level	Cooling	dB(A)	64.0	64.5	65.0	65.0	
	Heating	dB(A)	65.5	66.5	67.5	68.0	
Operation temperature range	Cooling	CDB	-5 to 43				
	Heating	CWB	-20 to 15.5				

Note
 (*1) Rated conditions Cooling : Indoor 27 degC Dry Bulb / 19 degC Wet Bulb, Outdoor 35 degC Dry Bulb.
 Heating : Indoor 20 degC Dry Bulb, Outdoor 7 degC Dry Bulb / 6 degC WetBulb.
 Based on equivalent piping length of 7.5 m and piping height difference of 0 m.
 (*2) Voltage range : Units are suitable for use on electrical systems where voltage supplied to unit terminal is not below or above listed range limits.
 (*3) Discharge temp. sensor / Suction temp. sensor / High-pressure sensor / Low-pressure sensor / High-pressure switch / P.C. board fuse
 (*4) Select wire size base on the larger value of MCA.
 MCA : Minimum Circuit Amps
 (*5) MOCP : Maximum Overcurrent Protection (Amps)



5-2. Dimensional drawing

Single unit

**Model : MMY-MAP0804HT8P-E, MAP0804T8P-E
MMY-MAP1004HT8P-E, MAP1004T8P-E
MMY-MAP1204HT8P-E, MAP1204T8P-E**

Applied model	A
MMY-MAP0804 type	ø 22.2
MMY-MAP1004 type	ø 22.2
MMY-MAP1204 type	ø 28.6

(Note)

1. If there is an obstacle at the upper side of the outdoor unit, set the top end of the outdoor unit 2000mm apart from the obstacle.
2. Limit the height of the obstacle surrounding the outdoor unit to 800mm or less from the bottom end of the outdoor unit.
3. Draw out the pipe procured locally to the front of the outdoor unit horizontally, and keep 500mm or more between the outdoor unit and traversing pipe if placing pipe transversely.
4. Dimensional drawing of corrosion protection and corrosion heavy protection model is the same as that of standard model.

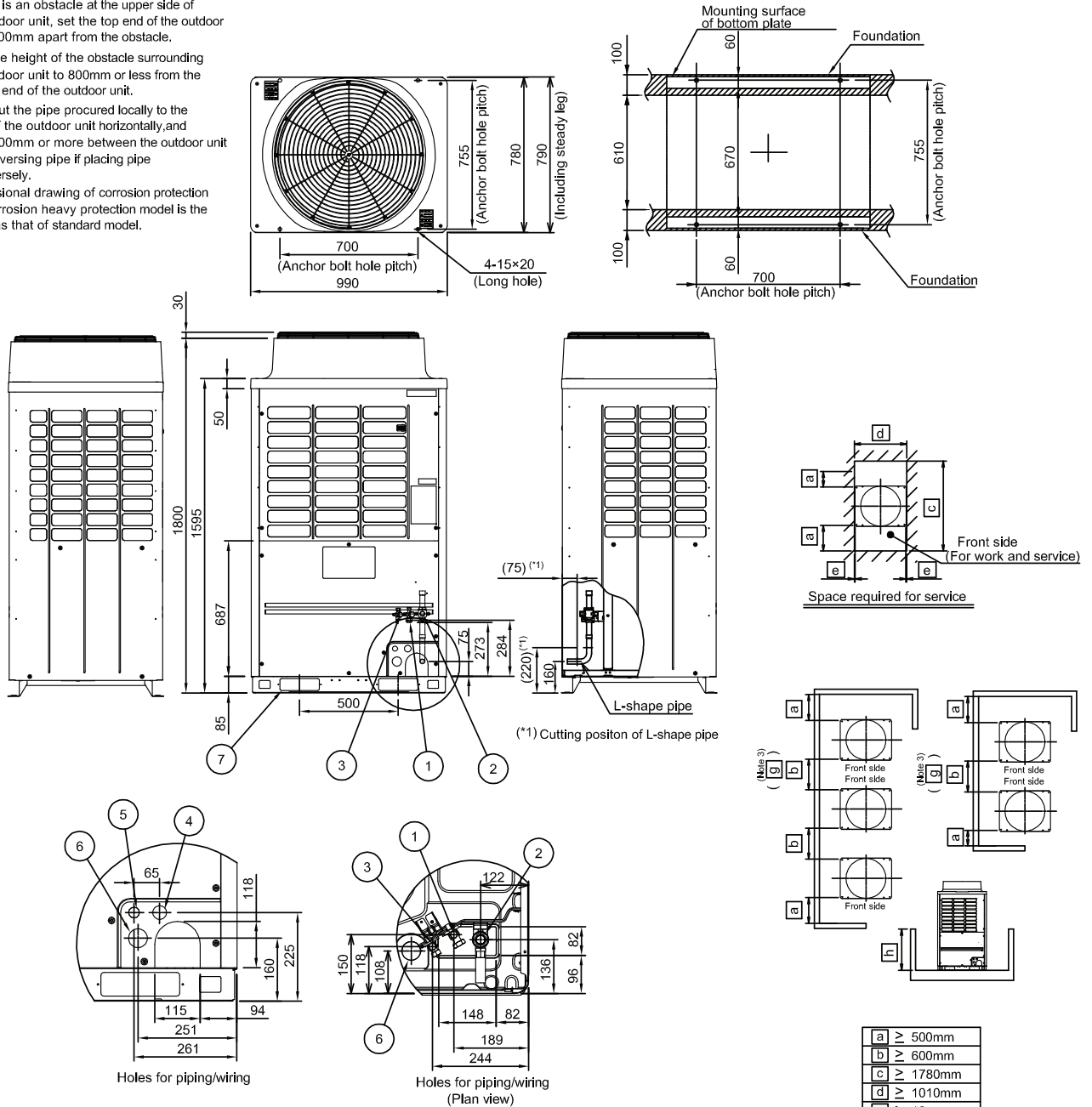

No	Parts name	Remarks
①	Liquid pipe connection port	ø12.7
②	Gas pipe connection port	øA
③	Balance pipe connection port	ø9.5
④	Knockout hole for power wiring 1	ø35
⑤	Knockout hole for control wiring	ø27
⑥	Knockout hole for power wiring 2	ø48
⑦	Square hole (for freight handling)	2-60X200

a	≥ 500mm
b	≥ 600mm
c	≥ 1780mm
d	≥ 1010mm
e	≥ 10mm
g	≥ 1000mm
h	≤ 800mm

(Unit : mm)

**Model : MMY-MAP1404HT8P-E, MAP1404T8P-E
MMY-MAP1604HT8P-E, MAP1604T8P-E**

(Note)

1. If there is an obstacle at the upper side of the outdoor unit, set the top end of the outdoor unit 2000mm apart from the obstacle.
2. Limit the height of the obstacle surrounding the outdoor unit to 800mm or less from the bottom end of the outdoor unit.
3. Draw out the pipe procured locally to the front of the outdoor unit horizontally, and keep 500mm or more between the outdoor unit and traversing pipe if placing pipe transversely.
4. Dimensional drawing of corrosion protection and corrosion heavy protection model is the same as that of standard model.

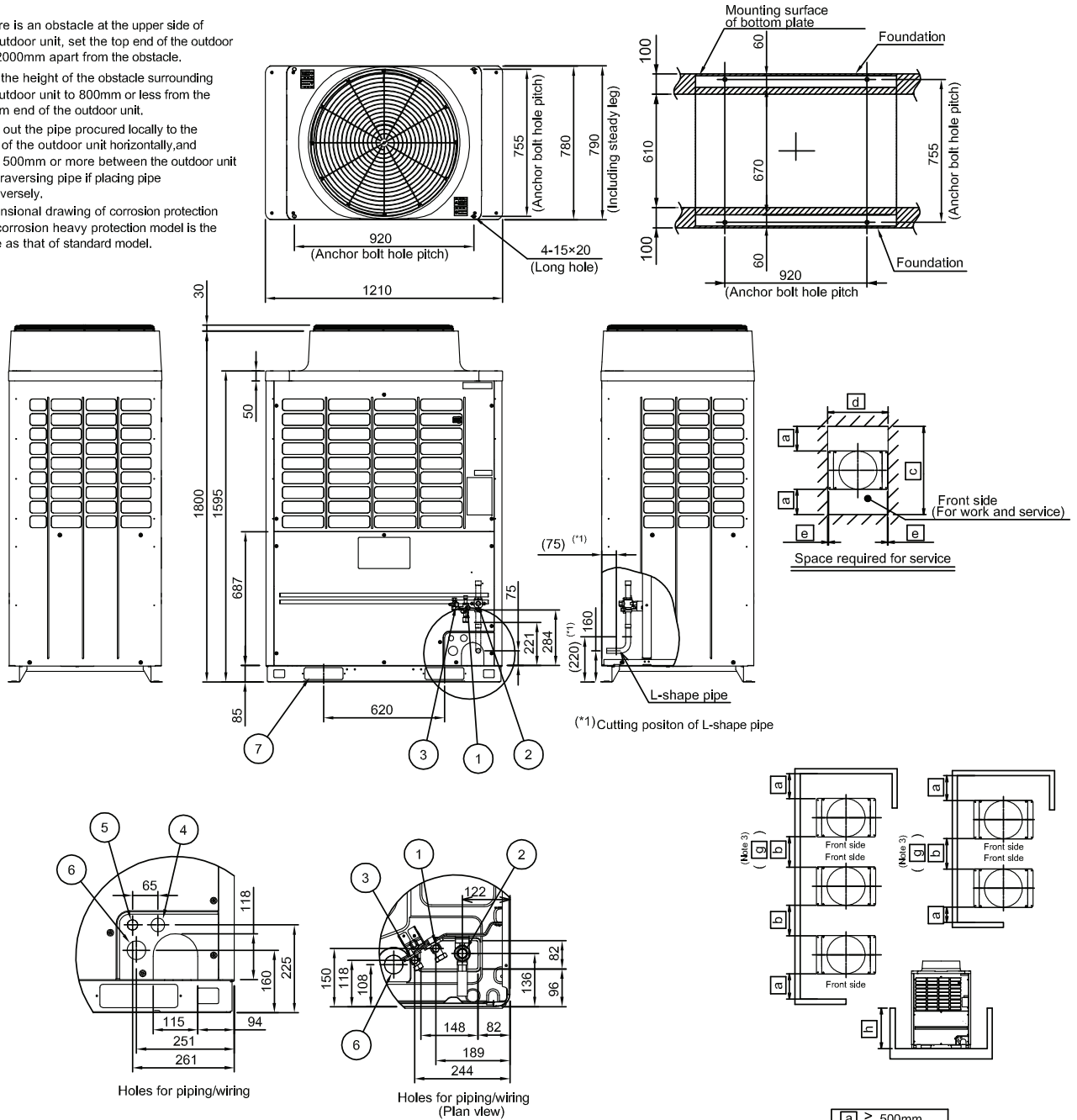

No	Parts name	Remarks
①	Liquid pipe connection port	φ15.9
②	Gas pipe connection port	φ28.6
③	Balance pipe connection port	φ9.5
④	Knockout hole for power wiring 1	φ35
⑤	Knockout hole for control wiring	φ27
⑥	Knockout hole for power wiring 2	φ48
⑦	Square hole (for freight handling)	2-60X200

a	≥ 500mm
b	≥ 600mm
c	≥ 1780mm
d	≥ 1230mm
e	≥ 10mm
g	≥ 1000mm
h	≤ 800mm

(Unit : mm)



Combination

(Note) All drawings are common with coding only model (MMY-AP_T8P-E)

Model	Outdoor unit	
	(1) Header unit	(2) Follower unit
MMY-AP1814HT8P-E	MMY-MAP1004HT8P-E	MMY-MAP0804HT8P-E
MMY-AP2014HT8P-E	MMY-MAP1004HT8P-E	MMY-MAP1004HT8P-E
MMY-AP2214HT8P-E	MMY-MAP1204HT8P-E	MMY-MAP1004HT8P-E
MMY-AP2414HT8P-E	MMY-MAP1204HT8P-E	MMY-MAP1204HT8P-E
MMY-AP1624HT8P-E	MMY-MAP0804HT8P-E	MMY-MAP0804HT8P-E

Two units connected

a	≥ 500mm
b	≥ 600mm
c	≥ 1780mm
d	≥ 2020mm
e	≥ 10mm
f	≥ 20mm
g	≥ 1000mm
h	≤ 800mm

Space required for service

(Unit:mm)

(Note)

- If there is an obstacle at the upper side of the outdoor unit, set the top end of the outdoor unit 2000mm apart from the obstacle.
- Limit the height of the obstacle surrounding the outdoor unit to 800mm or less from the bottom end of the outdoor unit.
- Draw out the pipe procured locally to the front of the outdoor unit horizontally and keep 500mm or more between the outdoor unit and traversing pipe if placing pipe transversely.
- Arrange each outdoor unit in order of its capacity.
(Header unit ⊙ ≥ Follower unit ⊙)
- Dimensional drawing of corrosion protection and corrosion heavy protection model is the same as that of standard model.

Model	Outdoor unit	
	(1) Header unit	(2) Follower unit
MMY-AP2614HT8P-E	MMY-MAP1604HT8P-E	MMY-MAP1004HT8P-E
MMY-AP2814HT8P-E	MMY-MAP1604HT8P-E	MMY-MAP1204HT8P-E

Two units connected

a	≥ 500mm
b	≥ 600mm
c	≥ 1780mm
d	≥ 2240mm
e	≥ 10mm
f	≥ 20mm
g	≥ 1000mm
h	≤ 800mm

Space required for service

(Unit:mm)

(Note)

- If there is an obstacle at the upper side of the outdoor unit, set the top end of the outdoor unit 2000mm apart from the obstacle.
- Limit the height of the obstacle surrounding the outdoor unit to 800mm or less from the bottom end of the outdoor unit.
- Draw out the pipe procured locally to the front of the outdoor unit horizontally and keep 500mm or more between the outdoor unit and traversing pipe if placing pipe transversely.
- Arrange each outdoor unit in order of its capacity.
(Header unit ⊙ ≥ Follower unit ⊙)
- Dimensional drawing of corrosion protection and corrosion heavy protection model is the same as that of standard model.



Model	Outdoor unit	
	(1) Header unit	(2) Follower unit
MMY-AP3014HT8P-E	MMY-MAP1604HT8P-E	MMY-MAP1404HT8P-E
MMY-AP3214HT8P-E	MMY-MAP1604HT8P-E	MMY-MAP1604HT8P-E

Two units connected

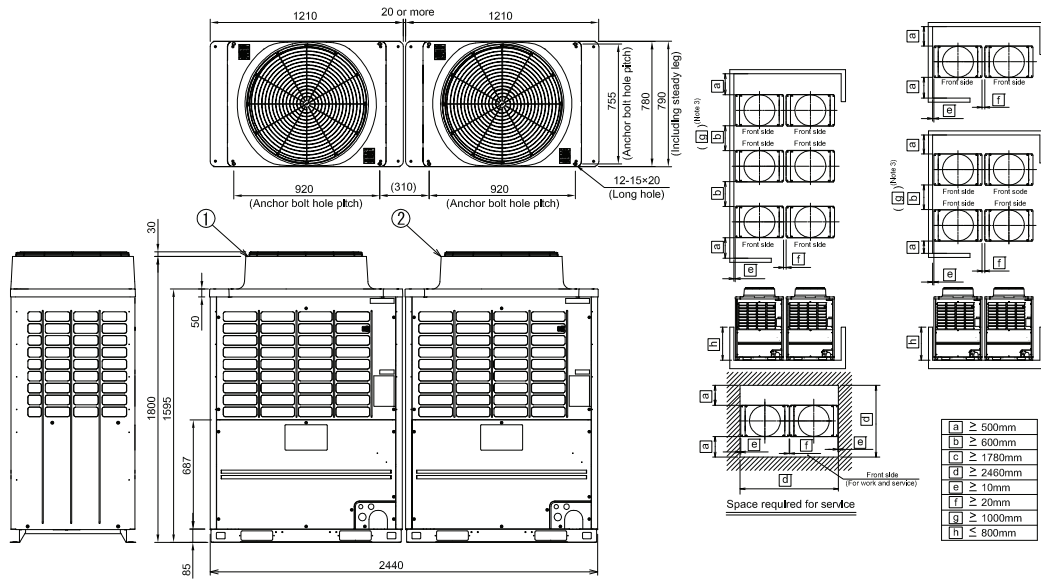

- (Note)
- If there is an obstacle at the upper side of the outdoor unit, set the top end of the outdoor unit 2000mm apart from the obstacle.
 - Limit the height of the obstacle surrounding the outdoor unit to 800mm or less from the bottom end of the outdoor unit.
 - Draw out the pipe procured locally to the front of the outdoor unit horizontally, and keep 500mm or more between the outdoor unit and traversing pipe if placing pipe transversely.
 - Arrange each outdoor unit in order of its capacity.
(Header unit ⊙ ≥ Follower unit ⊗)
 - Dimensional drawing of corrosion protection and corrosion heavy protection model is the same as that of standard model.

(Unit:mm)

Model	Outdoor unit		
	(1) Header unit	(2) Follower unit	(3) Header unit
MMY-AP3414HT8P-E	MMY-MAP1204HT8P-E	MMY-MAP1204HT8P-E	MMY-MAP1004HT8P-E
MMY-AP3614HT8P-E	MMY-MAP1204HT8P-E	MMY-MAP1004HT8P-E	MMY-MAP1204HT8P-E
MMY-AP2424HT8P-E	MMY-MAP0804HT8P-E	MMY-MAP0804HT8P-E	MMY-MAP0804HT8P-E
MMY-AP2624HT8P-E	MMY-MAP1004HT8P-E	MMY-MAP0804HT8P-E	MMY-MAP0804HT8P-E
MMY-AP2824HT8P-E	MMY-MAP1004HT8P-E	MMY-MAP1004HT8P-E	MMY-MAP0804HT8P-E
MMY-AP3024HT8P-E	MMY-MAP1004HT8P-E	MMY-MAP1004HT8P-E	MMY-MAP1004HT8P-E

Three units connected

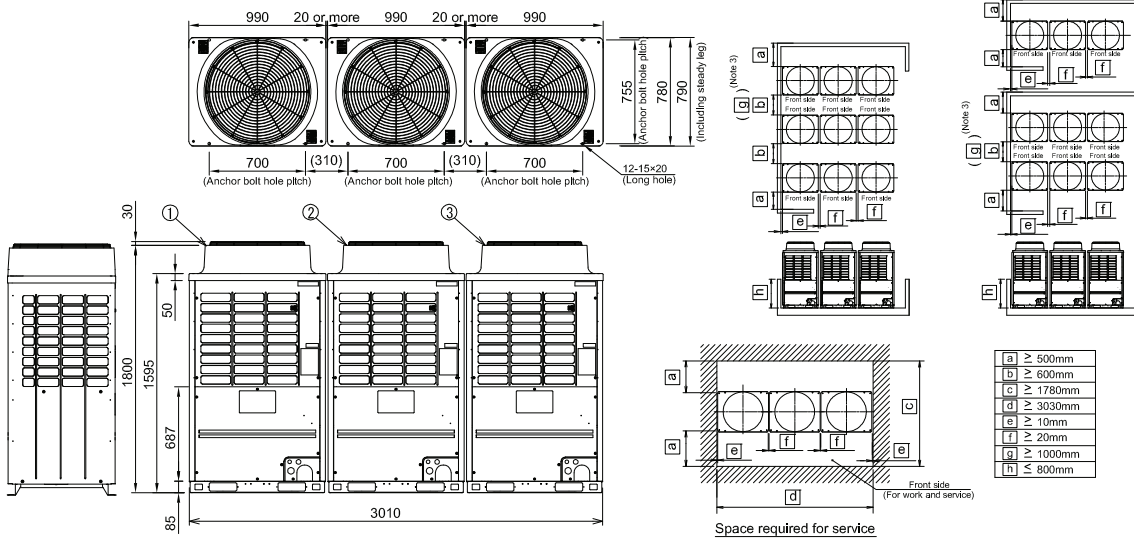

- (Note)
- If there is an obstacle at the upper side of the outdoor unit, set the top end of the outdoor unit 2000mm apart from the obstacle.
 - Limit the height of the obstacle surrounding the outdoor unit to 800mm or less from the bottom end of the outdoor unit.
 - Draw out the pipe procured locally to the front of the outdoor unit horizontally, and keep 500mm or more between the outdoor unit and traversing pipe if placing pipe transversely.
 - Arrange each outdoor unit in order of its capacity.
(Header unit ⊙ ≥ Follower unit ⊗ ≥ Follower unit ⊗)
 - Dimensional drawing of corrosion protection and corrosion heavy protection model is the same as that of standard model.

(Unit:mm)

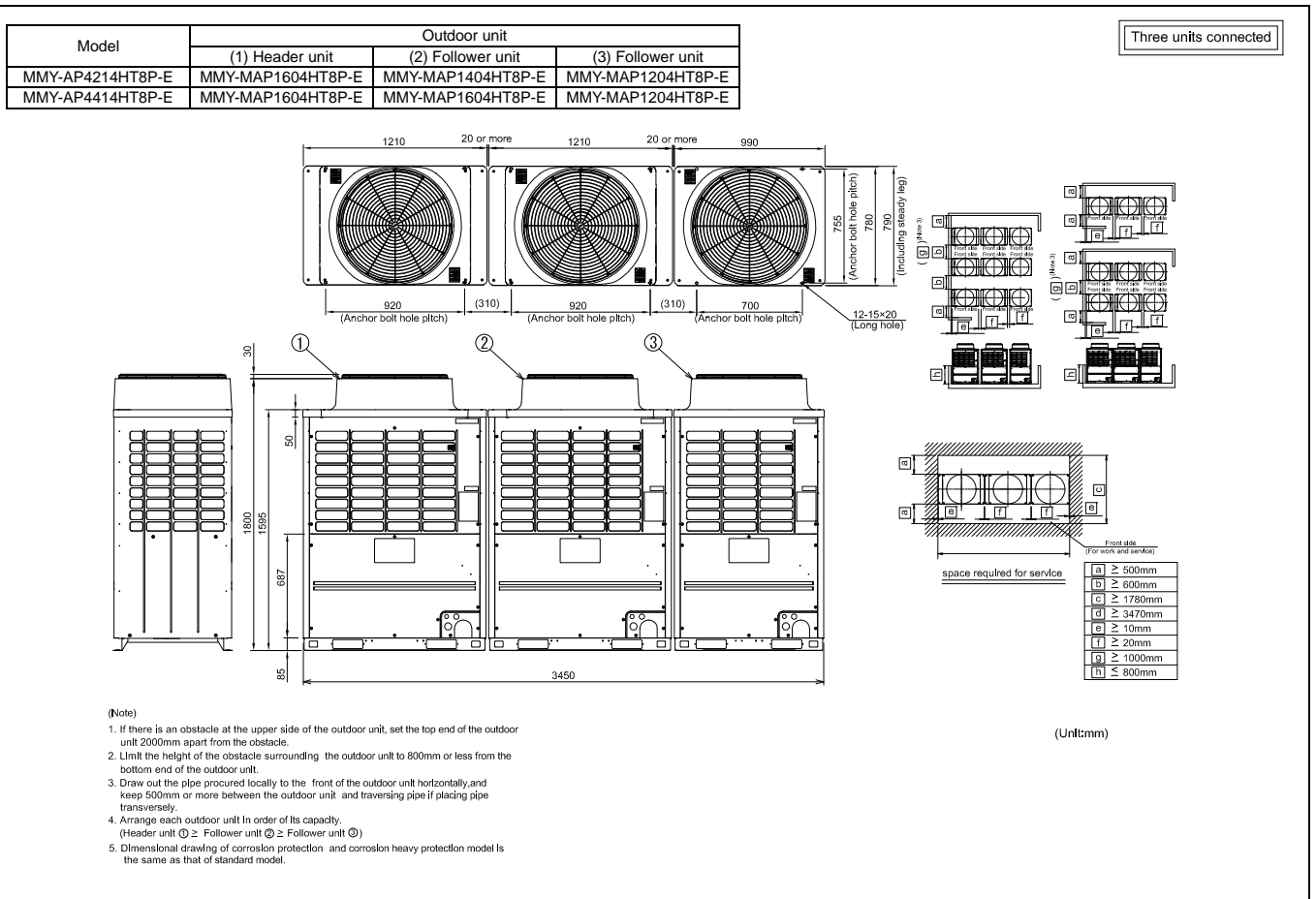
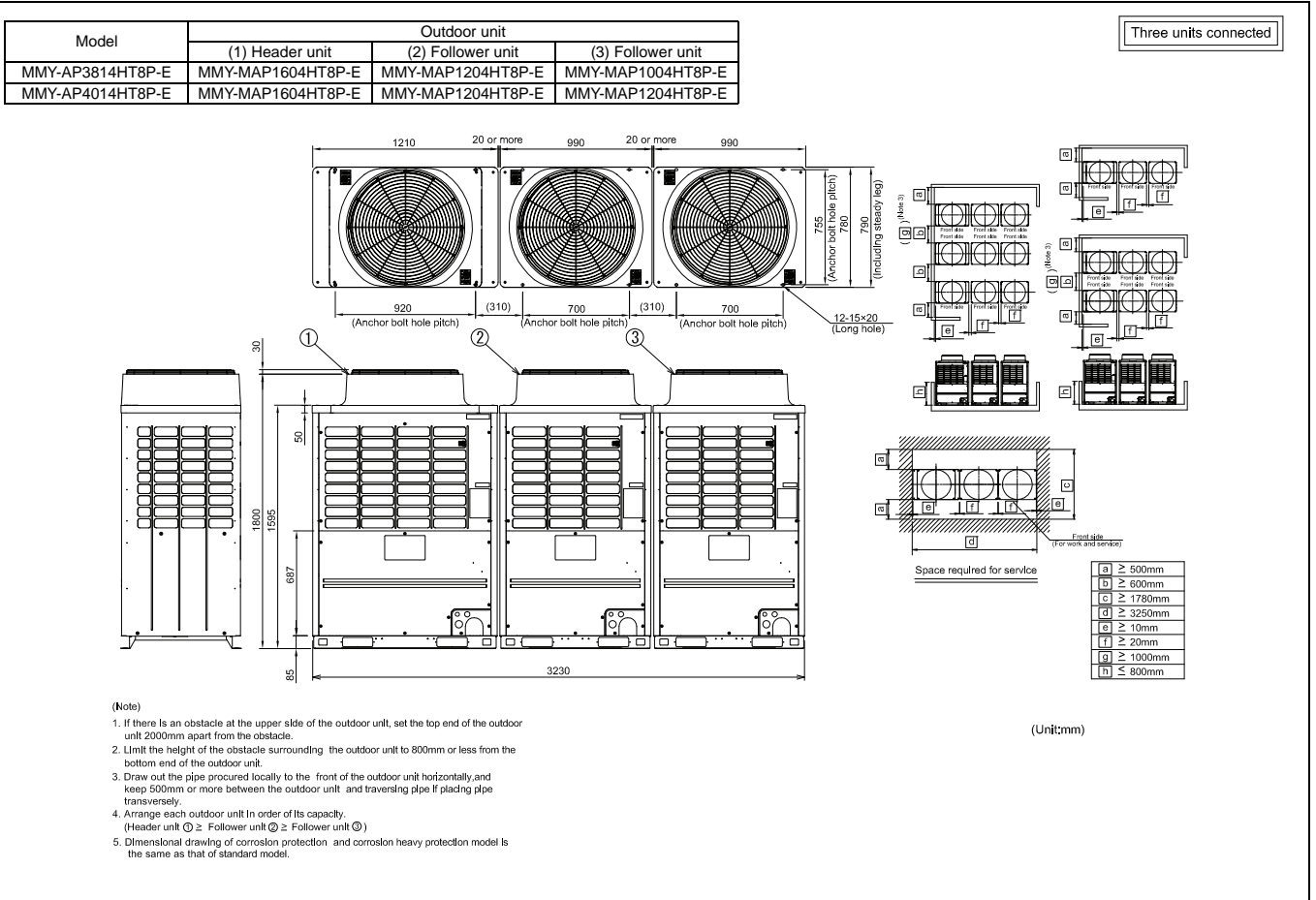



Model	Outdoor unit		
	(1) Header unit	(2) Follower unit	(3) Follower unit
MMY-AP4614HT8P-E	MMY-MAP1604HT8P-E	MMY-MAP1604HT8P-E	MMY-MAP1404HT8P-E
MMY-AP4814HT8P-E	MMY-MAP1604HT8P-E	MMY-MAP1604HT8P-E	MMY-MAP1604HT8P-E

Three units connected

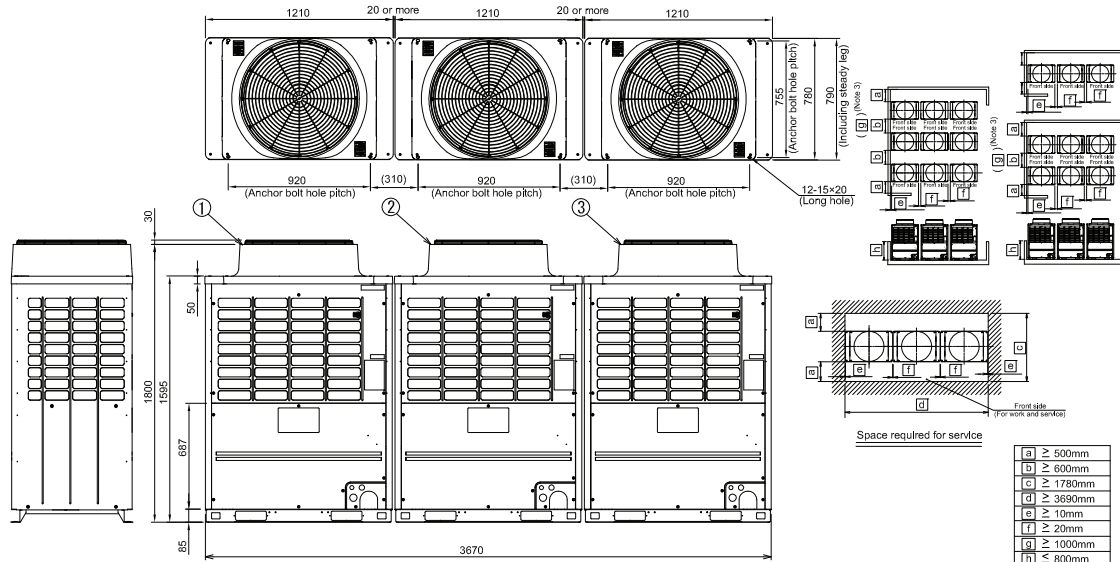

- (Note)
- If there is an obstacle at the upper side of the outdoor unit, set the top end of the outdoor unit 2000mm apart from the obstacle.
 - Limit the height of the obstacle surrounding the outdoor unit to 800mm or less from the bottom end of the outdoor unit.
 - Draw out the pipe procured locally to the front of the outdoor unit horizontally, and keep 500mm or more between the outdoor unit and traversing pipe if placing pipe transversely.
 - Arrange each outdoor unit in order of its capacity.
(Header unit ① ≥ Follower unit ② ≥ Follower unit ③)
 - Dimensional drawing of corrosion protection and corrosion heavy protection model is the same as that of standard model.

(Unit:mm)

Model	Outdoor unit			
	(1) Header unit	(2) Follower unit	(3) Follower unit	(4) Header unit
MMY-AP3224HT8P-E	MMY-MAP0804HT8P-E	MMY-MAP0804HT8P-E	MMY-MAP0804HT8P-E	MMY-MAP0804HT8P-E
MMY-AP3424HT8P-E	MMY-MAP1004HT8P-E	MMY-MAP0804HT8P-E	MMY-MAP0804HT8P-E	MMY-MAP0804HT8P-E
MMY-AP3624HT8P-E	MMY-MAP1004HT8P-E	MMY-MAP1004HT8P-E	MMY-MAP0804HT8P-E	MMY-MAP0804HT8P-E
MMY-AP3824HT8P-E	MMY-MAP1004HT8P-E	MMY-MAP1004HT8P-E	MMY-MAP1004HT8P-E	MMY-MAP0804HT8P-E
MMY-AP4024HT8P-E	MMY-MAP1004HT8P-E	MMY-MAP1004HT8P-E	MMY-MAP1004HT8P-E	MMY-MAP1004HT8P-E
MMY-AP4224HT8P-E	MMY-MAP1204HT8P-E	MMY-MAP1004HT8P-E	MMY-MAP1004HT8P-E	MMY-MAP1004HT8P-E
MMY-AP4424HT8P-E	MMY-MAP1204HT8P-E	MMY-MAP1204HT8P-E	MMY-MAP1004HT8P-E	MMY-MAP1004HT8P-E
MMY-AP4624HT8P-E	MMY-MAP1204HT8P-E	MMY-MAP1204HT8P-E	MMY-MAP1204HT8P-E	MMY-MAP1004HT8P-E
MMY-AP4824HT8P-E	MMY-MAP1204HT8P-E	MMY-MAP1204HT8P-E	MMY-MAP1204HT8P-E	MMY-MAP1204HT8P-E

Four units connected

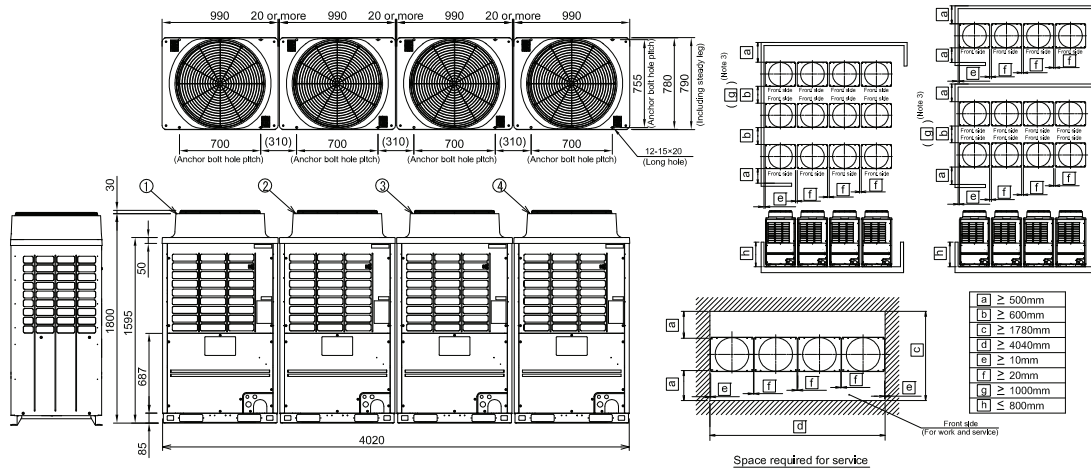

- (Note)
- If there is an obstacle at the upper side of the outdoor unit, set the top end of the outdoor unit 2000mm apart from the obstacle.
 - Limit the height of the obstacle surrounding the outdoor unit to 800mm or less from the bottom end of the outdoor unit.
 - Draw out the pipe procured locally to the front of the outdoor unit horizontally, and keep 500mm or more between the outdoor unit and traversing pipe if placing pipe transversely.
 - Arrange each outdoor unit in order of its capacity.
(Header unit ① ≥ Follower unit ② ≥ Follower unit ③)
 - Dimensional drawing of corrosion protection and corrosion heavy protection model is the same as that of standard model.

(Unit:mm)



5-3. Center of gravity

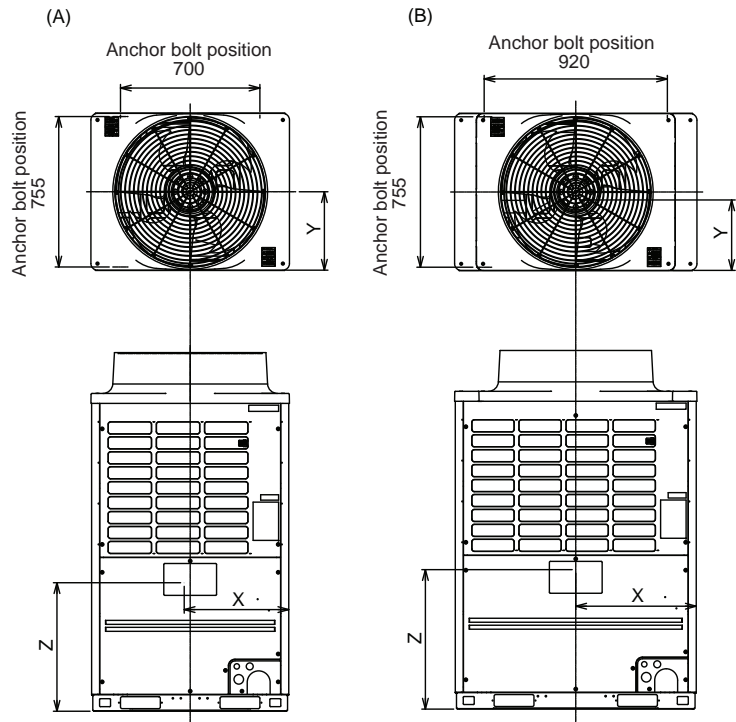

(Unit : mm)

No.	Model type	X (mm)	Y (mm)	Z (mm)	Mass (kg)
(A)	MMY-MAP0804 *	500	390	645	242 (cooling only : 241)
	MMY-MAP1004 *				
	MMY-MAP1204 *				
(B)	MMY-MAP1404 *	605	350	700	329
	MMY-MAP1604 *				



5-4. Branch header / branch joint

• Branch header

RBM-HY1043E, HY1083E, HY2043E, HY2083E

Gas side

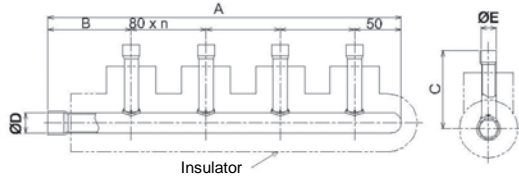

Liquid side

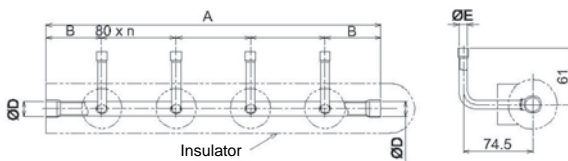

(Unit : mm)

Model		A	B	C	ØD	ØE	n	Accessory socket Qty
RBM-HY1043E	Gas side	380	90	83.6	22.2	15.9	3	⑥x 4, ⑨x 4, ⑭x 1, ⑱x 1, ⑳x 1
	Liquid side	360	60	-	15.9	9.5	3	①x 4, ⑥x 1, ⑨x 1
RBM-HY1083E	Gas side	700	90	83.6	22.2	15.9	7	⑥x 8, ⑨x 8, ⑭x 1, ⑱x 1, ⑳x 1
	Liquid side	680	60	-	15.9	9.5	7	①x 8, ⑥x 1, ⑨x 1
RBM-HY2043E	Gas side	385.5	95.5	89.3	31.8	15.9	3	⑥x 2, ⑨x 2, ⑳x 1, ㉑x 1
	Liquid side	360	60	-	15.9	9.5	3	①x 2
RBM-HY2083E	Gas side	705.5	95.5	89.3	31.8	15.9	7	⑥x 7, ⑨x 7, ⑳x 1, ㉑x 1
	Liquid side	680	60	-	15.9	9.5	7	①x 7

• Y-shape branch joint

RBM-BY55E, BY105E, BY205E, BY305E

Gas side

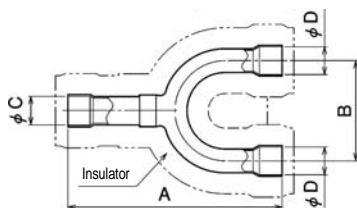

Liquid side

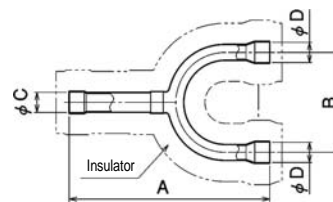

(Unit : mm)

RBM-		A	B	ØC	ØD	Accessory socket Qty
BY55E	Gas side	160	80	15.9	15.9	⑨x 1, ⑤①x 2, ⑨①x 2
	Liquid side	130	70	9.5	9.5	①x 2te
BY105E	Gas side	170	80	22.2	22.2	⑭x 2, ⑳x 2, ⑨①x 1
	Liquid side	160	80	15.9	15.9	⑨x 1, ⑨①x 1, ⑨②x 1
BY205E	Gas side	200	80	31.8	28.6	⑱x 1, ⑳x 1, ④③x 2, ⑤⑧x 1, ⑤⑨x 1, ⑨①x 1
	Liquid side	160	80	15.9	15.9	⑨x 1, ⑤①x 2, ⑨②x 1
BY305E	Gas side	220	80	38.1	38.1	④③x 1, ⑥①x 3, ⑥②x 2, ⑦①x 2, ⑦⑤x 1, ⑨①x 1
	Liquid side	170	80	22.2	22.2	⑨②x 1, ⑨④x 3



• Branching joint for connection of outdoor units (Set of three kinds of joint)
RBM-BT14E

Gas side

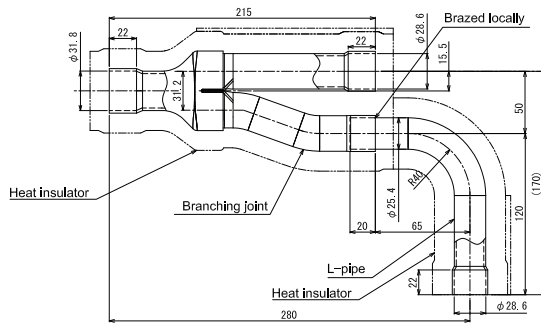

Liquid side

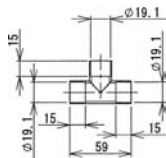

Balance pipe

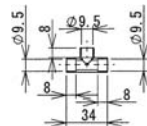

RBM-BT14E	
	Accessory socket Qty
Gas side	②7 x 1, ④3 x 2, ⑤9 x 1
Liquid side	⑩ x 2, ⑬ x 1

RBM-BT24E

Gas side

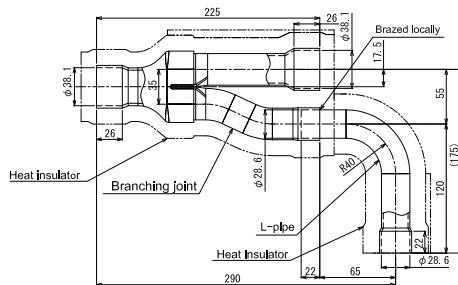

Liquid side

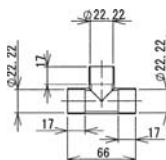

Balance pipe

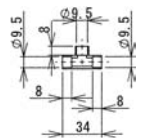

RBM-BT24E	
	Accessory socket Qty
Gas side	④3 x 1, ⑥1 x 2, ⑥2 x 2, ⑦1 x 1, ⑦3 x 1
Liquid side	⑭ x 2, ⑱ x 2, ⑳ x 1

(Unit : mm)

• Accessory socket

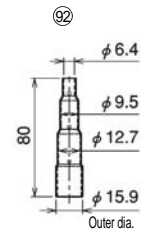
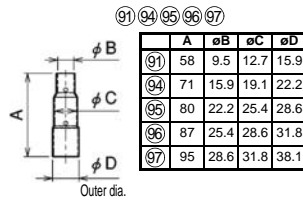
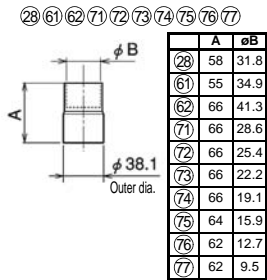
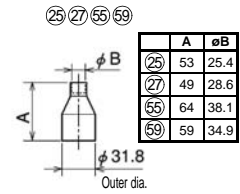
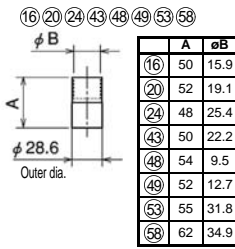
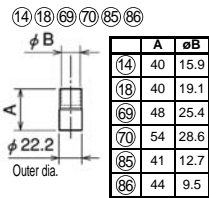
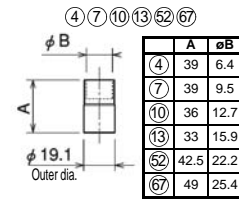
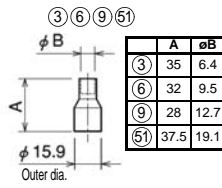
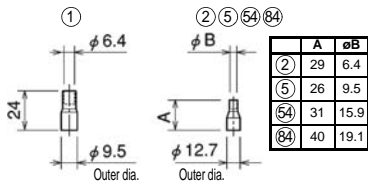

Closure tube

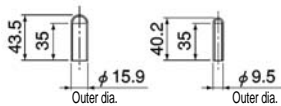

(Unit : mm)



5-5. Refrigerant cycle diagram

Model Name : MMY-MAP0804*, MMY-MAP1004*, MMY-MAP1204*

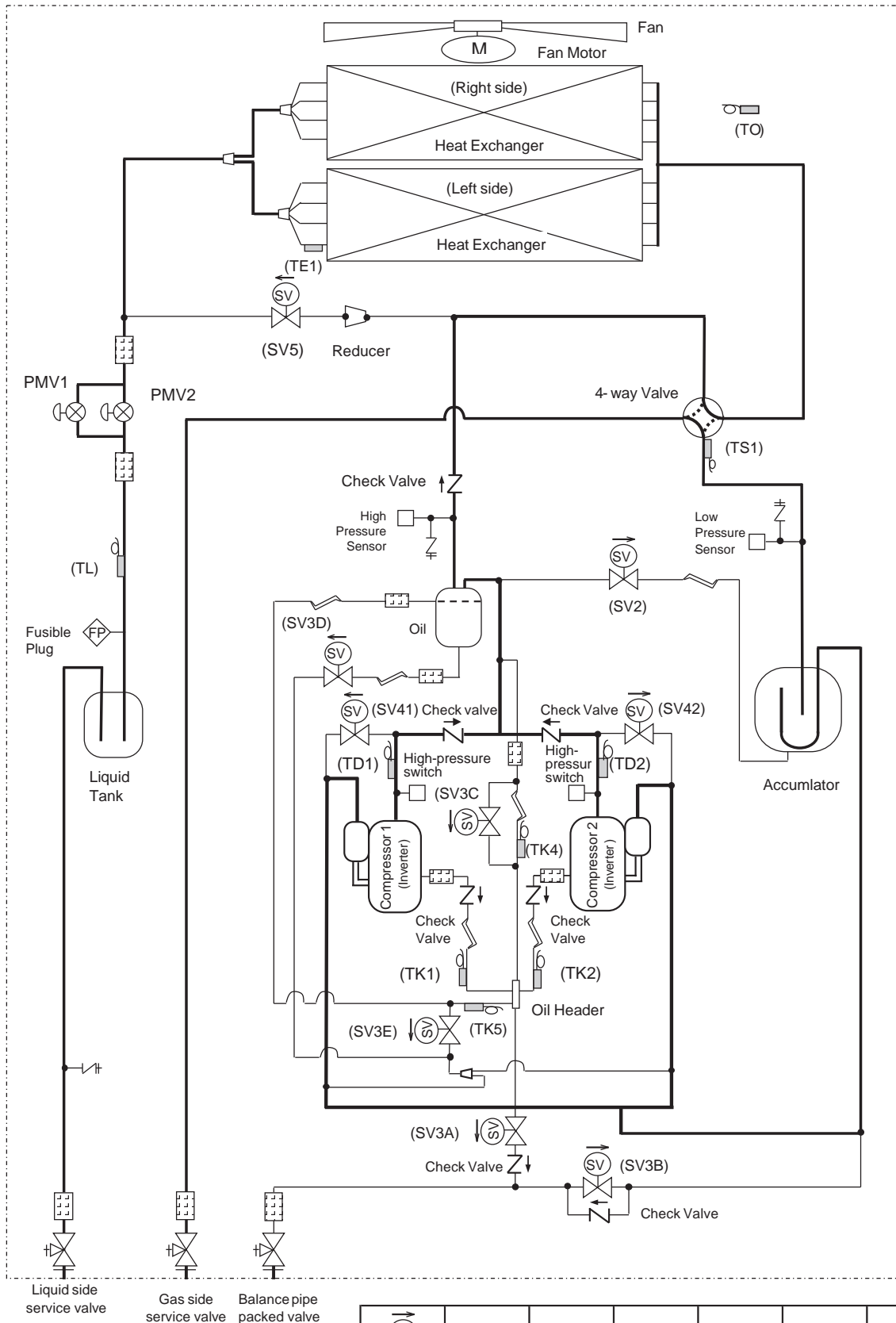

Liquid side service valve Gas side service valve Balance pipe packed valve

Solenoid Valve	Capillary Tube	Check Valve	Check Joint	Strainer	Temperature Sensor	Distributor



Model Name : MMY-MAP1404*, MMY-MAP1604*

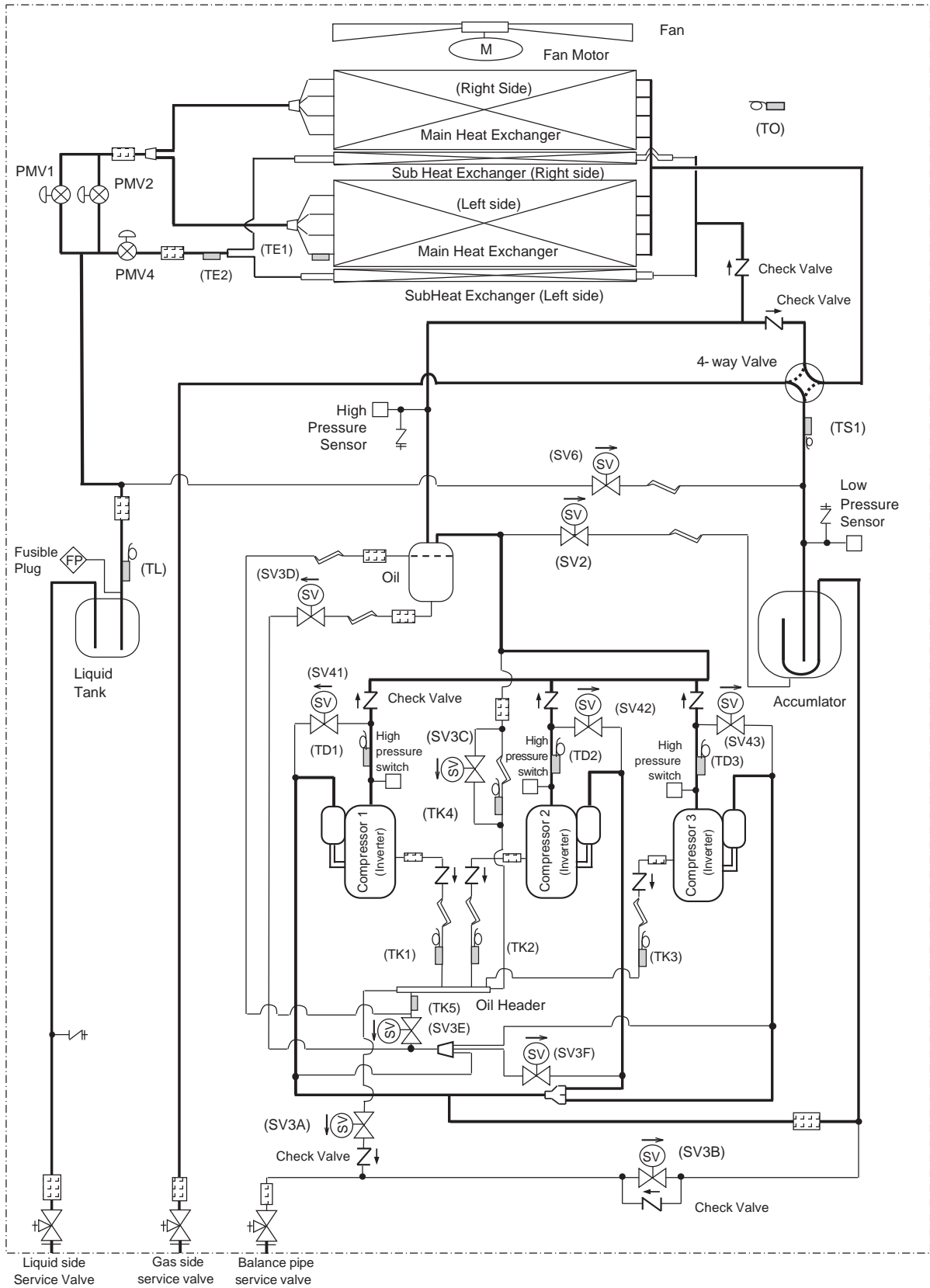

Liquid side service valve Gas side service valve Balance pipe service valve

Solenoid Valve	Capillary Tube	Check Valve	Check Joint	Strainer	Temperature Sensor	Distributor



5-7. Connecting diagram

SMMS-i Combination unit

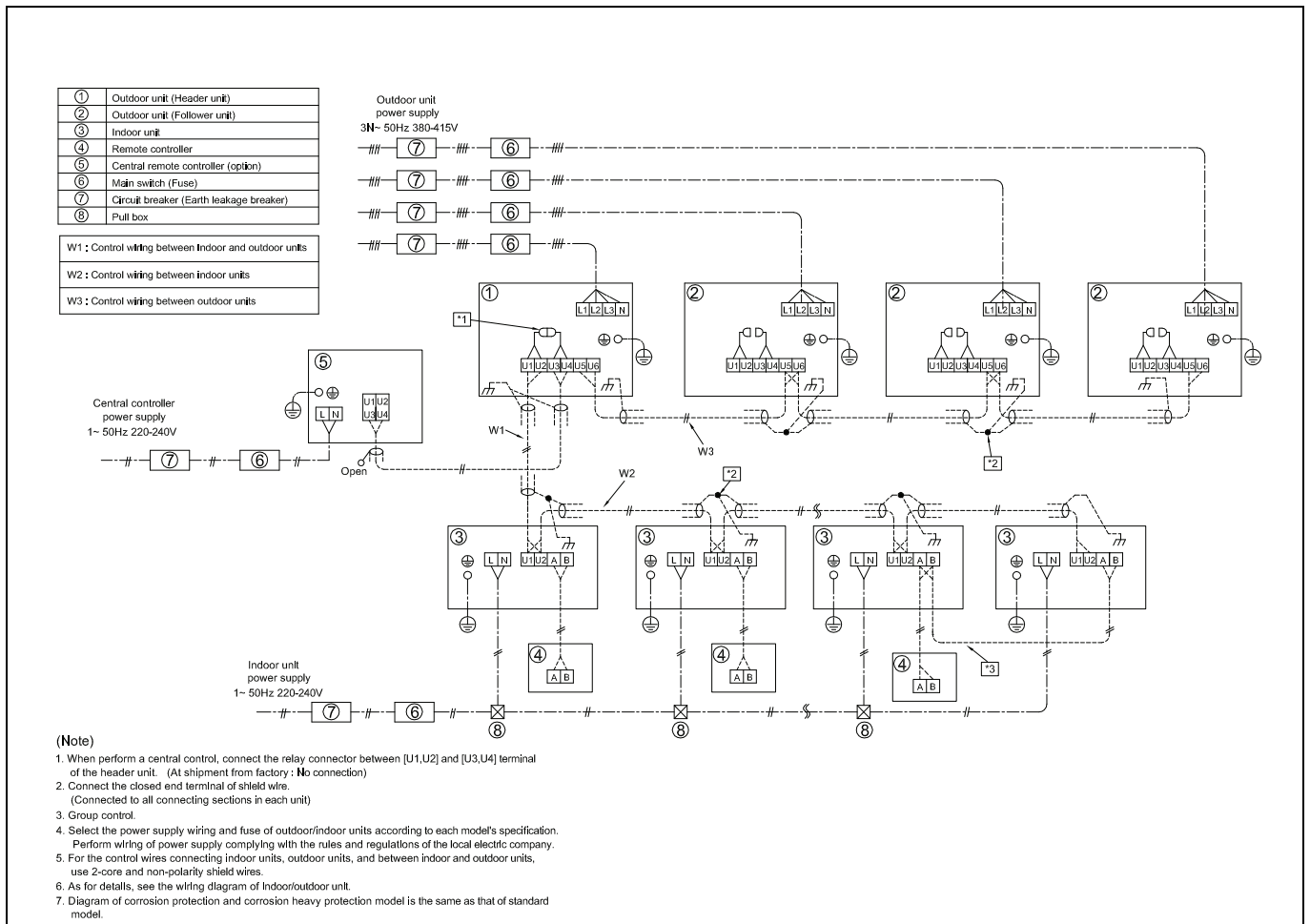



5-8. Applied control for Outdoor Unit

The outdoor fan high static pressure support and priority operation mode setting (cooling / heating / number of units / or priority indoor unit) functions are made available by setting relevant switches provided on the interface P.C. board of the outdoor unit.

5-8-1. Outdoor Fan High Static Pressure Shift

Purpose/characteristics

This function is used when connecting a duct to the discharge port of an outdoor unit (as part of, for example, unit installation on the floor by floor installation.)

Setup

Turn ON the DIP switch [SW10, Bit 2] provided on the interface P.C. board of the outdoor unit.

This function must be enabled with every discharge duct connected outdoor unit for both of the header and follower units.

Specification

Increase the speed of the propeller fan units on the outdoor fan to allow the installation of a duct with a maximum external static pressure not greater than specified in the table below. If a discharge duct with a resistance greater than 15 Pa (1.5 mmAq) is to be used, enable this function. The maximum external static pressures of base units are shown below (Table 1). In the case of combined use of multiple outdoor units, set all the units to the same maximum external static pressure as the one with the lowest maximum external static pressure (see Table 2).

Table 1: Maximum External Static Pressures of Base Outdoor Units

Model	MMY-	MAP0804*	MAP1004*	MAP1204*	MAP1404*	MAP1604*
Maximum external static pressure	(Pa)	60	60	50	40	40
(*) Outdoor unit air flow	(m ³ /h)	9900	10500	11600	12000	13000

(*) Calculate duct resistance from outdoor unit air flow.

Table 2: Maximum External Static Pressures for Combined Use of Base Units

(1) Standard models

Combined horsepower output	Model MMY-	Combination of outdoor units			Maximum external static pressure (Pa)
		Unit 1	Unit 2	Unit 3	
8	MAP0804*	MAP0804*			60
10	MAP1004*	MAP1004*			60
12	MAP1204*	MAP1204*			50
14	MAP1404*	MAP1404*			40
16	MAP1604*	MAP1604*			40
18	AP1814*	MAP1004*	MAP0804*		60
20	AP2014*	MAP1004*	MAP1004*		60
22	AP2214*	MAP1204*	MAP1004*		50
24	AP2424*	MAP1204*	MAP1204*		50
26	AP2624*	MAP1604*	MAP1004*		40
28	AP2824*	MAP1604*	MAP1204*		40
30	AP3024*	MAP1604*	MAP1404*		40
32	AP3224*	MAP1604*	MAP1604*		40
34	AP3424*	MAP1204*	MAP1204*	MAP1004*	50
36	AP3624*	MAP1204*	MAP1204*	MAP1204*	50
38	AP3824*	MAP1604*	MAP1204*	MAP1004*	40
40	AP4024*	MAP1604*	MAP1204*	MAP1204*	40
42	AP4224*	MAP1604*	MAP1404*	MAP1204*	40
44	AP4424*	MAP1604*	MAP1604*	MAP1204*	40
46	AP4624*	MAP1604*	MAP1604*	MAP1404*	40
48	AP4824*	MAP1604*	MAP1604*	MAP1604*	40



(2) High efficiency models

Combined horsepower output	Model MMY-	Combination of outdoor units				Maximum external static pressure (Pa)
		Unit 1	Unit 2	Unit 3	Unit 4	
16	AP1614*	MAP0804*	MAP0804*			60
24	AP2414*	MAP0804*	MAP0804*	MAP0804*		60
26	AP2614*	MAP1004*	MAP0804*	MAP0804*		60
28	AP2814*	MAP1004*	MAP1004*	MAP0804*		60
30	AP3014*	MAP1004*	MAP1004*	MAP1004*		60
32	AP3214*	MAP0804*	MAP0804*	MAP0804*	MAP0804*	60
34	AP3414*	MAP1004*	MAP0804*	MAP0804*	MAP0804*	60
36	AP3614*	MAP1004*	MAP1004*	MAP0804*	MAP0804*	60
38	AP3814*	MAP1004*	MAP1004*	MAP1004*	MAP0804*	60
40	AP4014*	MAP1004*	MAP1004*	MAP1004*	MAP1004*	60
42	AP4214*	MAP1204*	MAP1004*	MAP1004*	MAP1004*	50
44	AP4414*	MAP1204*	MAP1204*	MAP1004*	MAP1004*	50
46	AP4614*	MAP1204*	MAP1204*	MAP1204*	MAP1004*	50
48	AP4814*	MAP1204*	MAP1204*	MAP1204*	MAP1204*	50

5-8-2. Priority Operation Mode Setting

Purpose/characteristics

This function allows switching between priority cooling and priority heating.

Four patterns of priority operation mode setting are available as shown in the table below. Select a suitable priority mode according to the needs of the customer.

Setup



In the case of the priority indoor unit mode, it is necessary to set up the specific indoor unit chosen for priority operation (a single unit only).

(1) Outdoor unit setup method (header unit)

SW11		Operation
Bit 1	Bit 2	
OFF	OFF	Priority heating (factory default)
ON	OFF	Priority cooling
OFF	ON	Priority operation based on No. of units in operation (priority given to the operation mode with the largest share of units in operation)
ON	ON	Priority indoor unit (priority given to the operation mode of the specific indoor unit set up for priority operation)



(2) Indoor unit setup method for priority indoor unit mode

The setting can be changed only when the system is at rest. (Be sure to turn off the system prior to this operation.)

- 1 Push the **TEST** + **SET** + **CL** buttons simultaneously and hold for at least 4 seconds. The display window will start flashing in a little while.

Verify that the displayed CODE No. is 10.

- If the displayed CODE No. is not 10, press the **TEST** button to erase the display and repeat the procedure from the beginning.
(Note that the system does not respond to remote controller operation for about 1 minute after the **TEST** button is pushed.)
(In the case of group control, the indoor unit No. displayed first indicates the header unit.)

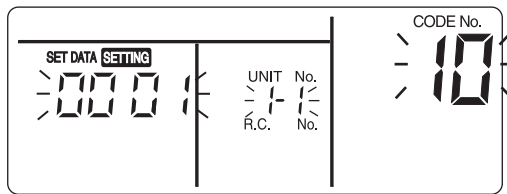
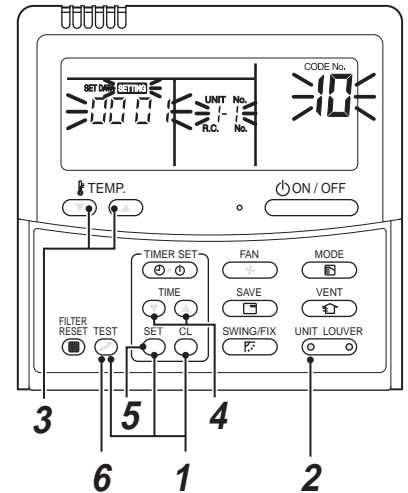

- 2 Each time the **UNIT LOUVER** button is pushed, one of the indoor unit Nos. under group control is displayed in turn. Select the indoor unit whose setting is to be changed.

The fan and flap of the selected indoor unit then come on, so that the position of this unit can be confirmed.

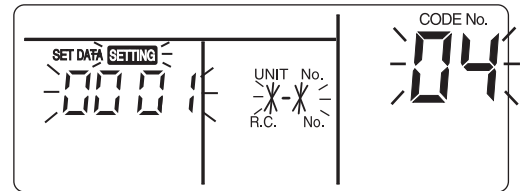

- 3 Use the **TEMP.** button to select the **CODE No. 04**.
- 4 Use the **TIME** button to select the **SET DATA 0001**.
Priority set 0001 No priority set 0000
- 5 Push the **SET** button.

The setup is finished when the display changes from flashing to steady.

- 6 Upon finishing the setup, push the **TEST** button. (This finalizes the setting.)

When the **TEST** button is pushed, the display goes blank, and the system returns to normal off state.

(Note that the system does not respond to remote controller operation for about 1 minute after the **TEST** button is pushed.)

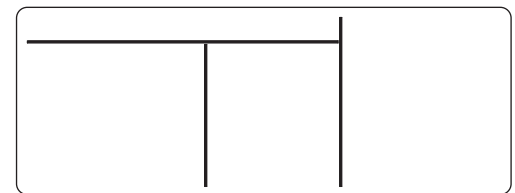

NOTE

Priority can be given to only one indoor unit. If more than one indoor unit is accidentally set to priority, an error code (L5 or L6: Duplicated indoor unit priority setting) will be displayed.

All units displaying L5 have been set to 0001 (priority). Keep the unit to which priority should be given as it is, and change the value back to 0000 (no priority) for all the rest.



Error code	Description
L5	Duplicated indoor unit priority setting (The unit is set to 0001.)
L6	Duplicated indoor unit priority setting (The unit is set to 0000.)



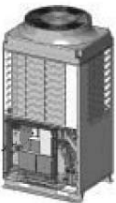
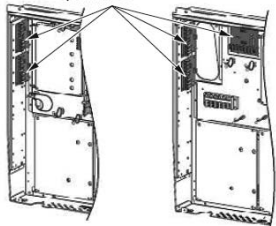
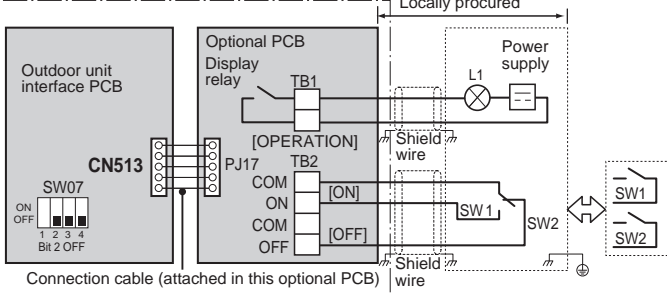

5-9. Optional printed circuit board (PCB) of outdoor unit

Model name	Appearance	Function																		
TCB-PCDM4E	 <p>Size: 71 x 85 (mm)</p>	<p>[1] Power peak-cut Control</p> <ul style="list-style-type: none"> Purpose: Limiting air conditioning performance with external signals and decreasing the peak power consumption. Feature The upper limit capacity of the outdoor unit is restricted based on the outdoor power peak selected setting. <p>Standard Specifications (Wiring example)</p>																		
	<p>Application</p>  <p>MMY-MAP080 to 120 MMY-MAP140 to 160</p> <p>Optional PCB</p>  <p>(max. number installed: 1 pc)</p> <p>* Install the optional PCB in the outdoor header unit.</p>	<p>Header outdoor unit L1: Display lamp during power peak cut control</p>  <p>Locally procured</p> <p>For SW1 and SW2, be sure to provide no-voltage contacts for each terminal. The input signals of SW1 and SW2 may be pulse input (100 msec or more) or continuous make. Do not turn on [SW1] and [SW2] simultaneously.</p> <p><SW07 (bit 2) OFF [2-stage switching]></p> <table border="1" data-bbox="550 1160 1469 1368"> <thead> <tr> <th colspan="2">Input</th> <th colspan="2">SW07 (bit 1)</th> <th rowspan="2">Display relay (L1)</th> </tr> <tr> <th>SW1</th> <th>SW2</th> <th>Bit 1 OFF</th> <th>Bit 1 ON</th> </tr> </thead> <tbody> <tr> <td>OFF</td> <td>ON</td> <td>100 % (normal operation)</td> <td>100 % (normal operation)</td> <td>OFF</td> </tr> <tr> <td>ON</td> <td>OFF</td> <td>0 % (forced stop)</td> <td>Approx. 60 % (upper limit regulated)</td> <td>ON</td> </tr> </tbody> </table>	Input		SW07 (bit 1)		Display relay (L1)	SW1	SW2	Bit 1 OFF	Bit 1 ON	OFF	ON	100 % (normal operation)	100 % (normal operation)	OFF	ON	OFF	0 % (forced stop)	Approx. 60 % (upper limit regulated)
Input		SW07 (bit 1)		Display relay (L1)																
SW1	SW2	Bit 1 OFF	Bit 1 ON																	
OFF	ON	100 % (normal operation)	100 % (normal operation)	OFF																
ON	OFF	0 % (forced stop)	Approx. 60 % (upper limit regulated)	ON																

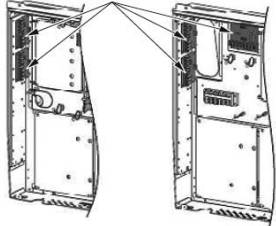
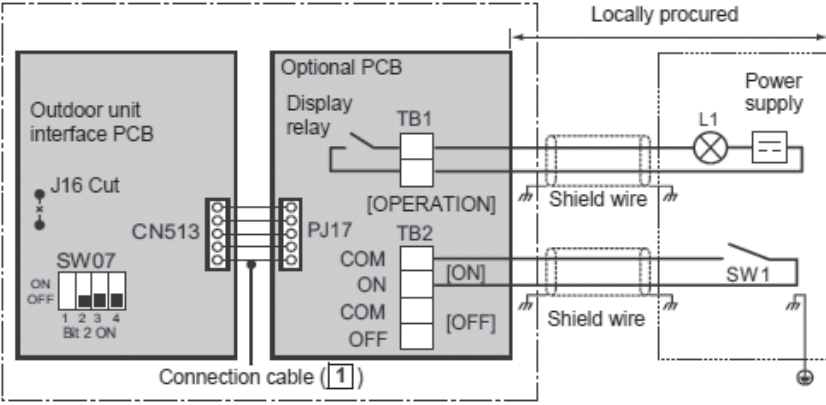
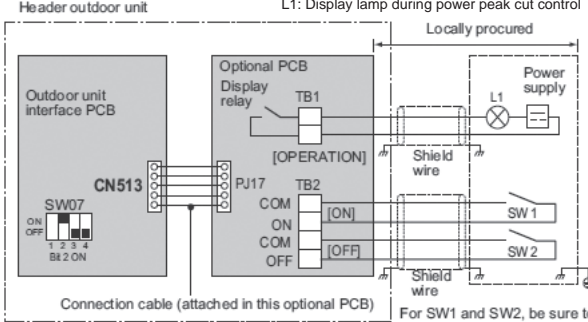



Model name	Appearance	Function																																												
<p style="writing-mode: vertical-rl; transform: rotate(180deg);">TCB-PCMO4E</p>	 <p>Size: 55.5 x 60 (mm)</p>	<p>For one input function</p> <p>Power peak-cut ON-OFF control is made possible on the SMMS-i on only the [ON] terminal input (SW1) by cutting the jumper lead (J16) of the center outdoor unit interface PCB. (Wiring example)</p>																																												
	<p>Application</p>  <p>MMY-MAP080 to 120 MMY-MAP140 to 160 Optional PCB</p>  <p>(max. number installed: 1 pc)</p> <p>* Install the optional PCB in the outdoor header unit.</p>	<p>Header outdoor unit L1: Display lamp during power peak cut control</p>  <p><SW07 (bit 2) OFF [2-stage switching]></p> <p>Power peak-cut control turns ON when SW1 in the wiring example is ON (continuous make).</p> <table border="1" data-bbox="549 1077 1458 1234"> <thead> <tr> <th rowspan="2">Jumper lead J16</th> <th rowspan="2">Input SW1</th> <th colspan="2">SW07 (bit 1)</th> <th rowspan="2">Display relay (L1)</th> </tr> <tr> <th>Bit 1 OFF</th> <th>Bit 1 ON</th> </tr> </thead> <tbody> <tr> <td rowspan="2">Cut</td> <td>OFF</td> <td>100% (normal operation)</td> <td>100% (normal operation)</td> <td>OFF</td> </tr> <tr> <td>ON</td> <td>0% (forced stop)</td> <td>Approx. 60% (upper limit regulated)</td> <td>ON</td> </tr> </tbody> </table> <p>Enhanced Specifications (Wiring example)</p>  <p>Header outdoor unit L1: Display lamp during power peak cut control</p> <p>For SW1 and SW2, be sure to provide no-voltage contacts for each terminal.</p> <p><SW07 (bit 2) ON [4-stage switching]></p> <table border="1" data-bbox="549 1756 1369 2056"> <thead> <tr> <th colspan="2">Input</th> <th colspan="2">SW07 (bit 1)</th> <th rowspan="2">Display relay (L1)</th> </tr> <tr> <th>SW1</th> <th>SW2</th> <th>Bit 1 OFF</th> <th>Bit 1 ON</th> </tr> </thead> <tbody> <tr> <td>OFF</td> <td>OFF</td> <td>100% (normal operation)</td> <td>100% (normal operation)</td> <td>OFF</td> </tr> <tr> <td>ON</td> <td>OFF</td> <td>Approx. 80% (upper limit regulated)</td> <td>Approx. 85% (upper limit regulated)</td> <td>ON</td> </tr> <tr> <td>OFF</td> <td>ON</td> <td>Approx. 60% (upper limit regulated)</td> <td>Approx. 75% (upper limit regulated)</td> <td>ON</td> </tr> <tr> <td>ON</td> <td>ON</td> <td>0% (forced stop)</td> <td>Approx. 60% (upper limit regulated)</td> <td>ON</td> </tr> </tbody> </table>	Jumper lead J16	Input SW1	SW07 (bit 1)		Display relay (L1)	Bit 1 OFF	Bit 1 ON	Cut	OFF	100% (normal operation)	100% (normal operation)	OFF	ON	0% (forced stop)	Approx. 60% (upper limit regulated)	ON	Input		SW07 (bit 1)		Display relay (L1)	SW1	SW2	Bit 1 OFF	Bit 1 ON	OFF	OFF	100% (normal operation)	100% (normal operation)	OFF	ON	OFF	Approx. 80% (upper limit regulated)	Approx. 85% (upper limit regulated)	ON	OFF	ON	Approx. 60% (upper limit regulated)	Approx. 75% (upper limit regulated)	ON	ON	ON	0% (forced stop)	Approx. 60% (upper limit regulated)
Jumper lead J16	Input SW1	SW07 (bit 1)			Display relay (L1)																																									
		Bit 1 OFF	Bit 1 ON																																											
Cut	OFF	100% (normal operation)	100% (normal operation)	OFF																																										
	ON	0% (forced stop)	Approx. 60% (upper limit regulated)	ON																																										
Input		SW07 (bit 1)		Display relay (L1)																																										
SW1	SW2	Bit 1 OFF	Bit 1 ON																																											
OFF	OFF	100% (normal operation)	100% (normal operation)	OFF																																										
ON	OFF	Approx. 80% (upper limit regulated)	Approx. 85% (upper limit regulated)	ON																																										
OFF	ON	Approx. 60% (upper limit regulated)	Approx. 75% (upper limit regulated)	ON																																										
ON	ON	0% (forced stop)	Approx. 60% (upper limit regulated)	ON																																										

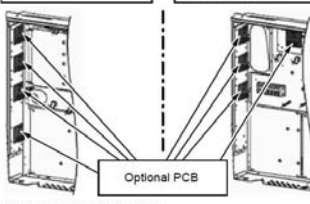
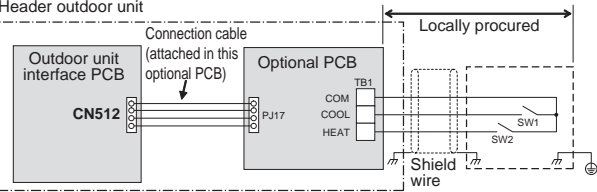
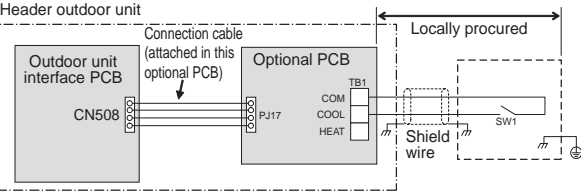



Model name	Appearance	Function																
TCB-PCMO4E	 <p>Size: 55.5 x 60 (mm)</p>	<p>[2] External master ON/OFF control</p> <ul style="list-style-type: none"> • Feature The outdoor unit starts or stop the system. • Function By connecting the cable (attached in this optional PCB) to the interface PC board on an outdoor unit, all indoor units connected to the outdoor unit enable to operate simultaneously. • Operation The outdoor unit connection is for the header unit (U1). 																
	<p>Application</p>  <p>MMY-MAP080 to 120 MMY-MAP140, 160</p>  <p>(max. number installed: 4 pcs)</p> <p>* Install the optional PCB in the outdoor header unit.</p>	 <p>Header outdoor unit</p> <p>SW1: Operation input switch SW2: Stop input switch</p> <table border="1" data-bbox="550 891 1465 1064"> <thead> <tr> <th>Terminal</th> <th>Input signal</th> <th>Operation</th> </tr> </thead> <tbody> <tr> <td>COOL (SW1)</td> <td>ON OFF</td> <td>All indoor units operate together</td> </tr> <tr> <td>HEAT (SW2)</td> <td>ON OFF</td> <td>All indoor units stop together</td> </tr> </tbody> </table> <p>Provide no-voltage pulse contacts for each terminal. Hold the ON state for at least 100 msec. Do not turn SW1 and SW2 ON simultaneously</p> <p>[3] Night time operation (sound reduction) control</p> <ul style="list-style-type: none"> • Purpose: Reducing noise from an outdoor unit • Feature Sound level can be reduced by restricting the compressor and fan speed • Function As the cable (attached in this optional PCB) is connected to the "Interface PCB" on an outdoor unit, both compressor speed and fan speed are restricted while the signal of the night operation control is input. It makes the noise reduction during the night time operation. • Operation The outdoor unit connection is for the header unit (U1).  <p>Header outdoor unit</p> <p>SW1: Night time signal switch</p> <table border="1" data-bbox="550 1792 1465 1964"> <thead> <tr> <th>Terminal</th> <th>Input signal</th> <th>Operation</th> </tr> </thead> <tbody> <tr> <td rowspan="2">COOL (SW1)</td> <td>ON OFF</td> <td>All indoor units operate together</td> </tr> <tr> <td>ON OFF</td> <td>All indoor units stop together</td> </tr> </tbody> </table> <p>Each terminal should be connected to dry contact. The input signal is recognized during its rising/falling phase. (After reaching the top/bottom of the rising/falling edge, the signal must remain there for at least 100 ms.)</p>	Terminal	Input signal	Operation	COOL (SW1)	ON OFF	All indoor units operate together	HEAT (SW2)	ON OFF	All indoor units stop together	Terminal	Input signal	Operation	COOL (SW1)	ON OFF	All indoor units operate together	ON OFF
Terminal	Input signal	Operation																
COOL (SW1)	ON OFF	All indoor units operate together																
HEAT (SW2)	ON OFF	All indoor units stop together																
Terminal	Input signal	Operation																
COOL (SW1)	ON OFF	All indoor units operate together																
	ON OFF	All indoor units stop together																

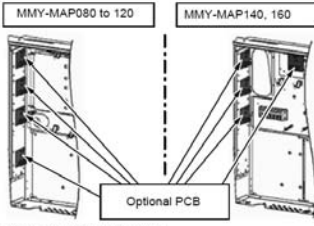
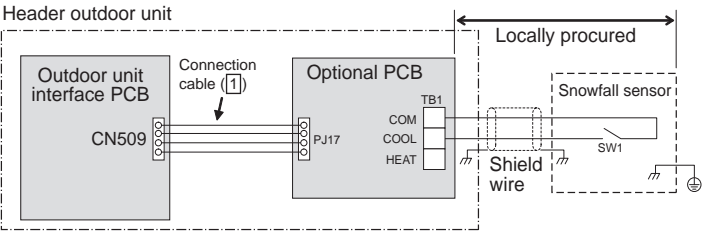



Model name	Appearance	Function																										
TCB-PCMO4E	 <p>Size: 55.5 x 60 (mm)</p>	<p>Sound reduction and approximation capacity (reference)</p> <table border="1" data-bbox="560 376 1460 600"> <thead> <tr> <th rowspan="2"></th> <th rowspan="2">Night operation sound reduction dB (A)</th> <th colspan="2">Capacity</th> </tr> <tr> <th>COOL</th> <th>HEAT</th> </tr> </thead> <tbody> <tr> <td>1604 type</td> <td>53</td> <td>Approx. 70%</td> <td>Approx. 70%</td> </tr> <tr> <td>1404 type</td> <td>53</td> <td>Approx. 80%</td> <td>Approx. 80%</td> </tr> <tr> <td>1204 type</td> <td>50</td> <td>Approx. 60%</td> <td>Approx. 55%</td> </tr> <tr> <td>1004 type</td> <td>50</td> <td>Approx. 70%</td> <td>Approx. 65%</td> </tr> <tr> <td>0804 type</td> <td>50</td> <td>Approx. 85%</td> <td>Approx. 80%</td> </tr> </tbody> </table>		Night operation sound reduction dB (A)	Capacity		COOL	HEAT	1604 type	53	Approx. 70%	Approx. 70%	1404 type	53	Approx. 80%	Approx. 80%	1204 type	50	Approx. 60%	Approx. 55%	1004 type	50	Approx. 70%	Approx. 65%	0804 type	50	Approx. 85%	Approx. 80%
		Night operation sound reduction dB (A)			Capacity																							
			COOL	HEAT																								
	1604 type	53	Approx. 70%	Approx. 70%																								
1404 type	53	Approx. 80%	Approx. 80%																									
1204 type	50	Approx. 60%	Approx. 55%																									
1004 type	50	Approx. 70%	Approx. 65%																									
0804 type	50	Approx. 85%	Approx. 80%																									
<p>Application</p>   <p>(max. number installed: 4 pcs)</p> <p>* Install the optional PCB in the outdoor header unit.</p>	<p>Condition</p> <p>Cooling: (Indoor 27 deg DB, 19 deg WB) (Outdoor temperature 25 deg DB)</p> <p>Heating: (Indoor 20 deg DB) (Outdoor temperature 7 deg DB, 6 deg WB)</p> <p>[4] Snowfall fan control</p> <ul style="list-style-type: none"> • Purpose: Rotating the fan to prevent snow accumulation • Feature <p>Outdoor fan is operated from the snowfall signal received from the outside.</p> <p>▼ Functions</p> <p>The outdoor unit fan operates at snowfall by connecting to the outdoor unit interface PCB.</p> <p>▼ Operation</p>  <p>SW1: Snowfall selection switch (snowfall sensor)</p> <table border="1" data-bbox="547 1413 1465 1585"> <thead> <tr> <th>Terminal</th> <th>Input signal</th> <th>Operation</th> </tr> </thead> <tbody> <tr> <td rowspan="4">Cooling (SW1)</td> <td>ON</td> <td rowspan="2">Snowfall fan control (Fan in outdoor unit operates.)</td> </tr> <tr> <td>OFF</td> </tr> <tr> <td>ON</td> <td rowspan="2">Normal operation</td> </tr> <tr> <td>OFF</td> </tr> </tbody> </table> <p>Be sure to provide no-voltage continuous contacts for each terminal.</p>	Terminal	Input signal	Operation	Cooling (SW1)	ON	Snowfall fan control (Fan in outdoor unit operates.)	OFF	ON	Normal operation	OFF																	
Terminal	Input signal	Operation																										
Cooling (SW1)	ON	Snowfall fan control (Fan in outdoor unit operates.)																										
	OFF																											
	ON	Normal operation																										
	OFF																											

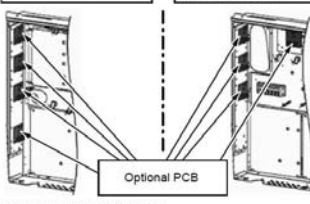
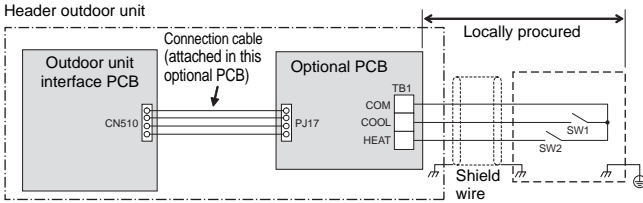

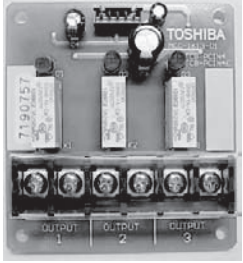
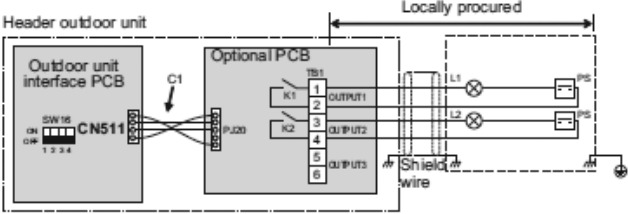

Model name	Appearance	Function																																																							
TCB-PCIN4E	 <p>Size: 55.5 x 60 (mm)</p>	<p>[5] Operation mode selection control</p> <ul style="list-style-type: none"> • Purpose: Limiting operation modes to cooling and heating only • Feature This control can restrict the selectable operation mode. <p>▼ Functions The heating/cooling mode of the system can be selected by connecting to the interface PCB of outdoor units.</p> <p>▼ Operation The outdoor unit connection is for the header unit (U1).</p>																																																							
	<p>Application</p>  <p>MMY-MAP080 to 120 MMY-MAP140, 160</p>  <p>(max. number installed: 4 pcs)</p> <p>* Install the optional PCB in the outdoor header unit.</p>	 <p>SW1: Cooling mode specified input switch SW2: Heating mode specified input switch</p> <table border="1" data-bbox="558 896 1189 1019"> <thead> <tr> <th colspan="2">Input Signal</th> <th rowspan="2">Operation: Selected operation mode</th> </tr> <tr> <th>Cooling (SW1)</th> <th>Heating (SW2)</th> </tr> </thead> <tbody> <tr> <td>ON</td> <td>OFF</td> <td>Cooling operation only</td> </tr> <tr> <td>OFF</td> <td>ON</td> <td>Heating operation only</td> </tr> <tr> <td>OFF</td> <td>OFF</td> <td>Normal operation</td> </tr> </tbody> </table> <p>Each terminal should be connected to dry contact.</p> <p>About Switching of Processing of Indoor Unit Operation State [Setting can be changed only on the SMMS-i.] Processing of the operation state can be switched for indoor units in a mode other than the selected operation mode by setting the jumper lead (J01) of the header outdoor unit interface PCB.</p> <table border="1" data-bbox="558 1265 1276 1803"> <thead> <tr> <th>Jumper lead</th> <th colspan="3">Details of Processing</th> </tr> </thead> <tbody> <tr> <td rowspan="4">J01 connected (factory default)</td> <td colspan="3">Unallowed indoor units in a mode other than the selected operation mode are not treated as priority (thermo OFF state). (Unallowed indoor units)</td> </tr> <tr> <td>Operation Mode</td> <td>Operation State</td> <td rowspan="3">Remote control indicator is displayed.</td> </tr> <tr> <td>Cooling unit</td> <td>Air blow operation at blow rate set on remote control</td> </tr> <tr> <td>Heating unit</td> <td>Air blow operation at super-slow blow rate</td> </tr> <tr> <td>Air blow unit</td> <td>Regular air blow operation at blow rate set on remote control</td> <td></td> </tr> <tr> <td rowspan="4">J01 cut</td> <td colspan="3">Indoor units in a mode other than the selected operation mode are forcibly switched to the selected operation mode.</td> </tr> <tr> <td>PC board selection mode</td> <td colspan="2">Remote control operation/display</td> </tr> <tr> <td>Normal</td> <td>*, Δ, ✱, or ☼ can be selected</td> <td rowspan="3">When using the remote control, (mode select control) indicator is displayed.</td> </tr> <tr> <td>Cool</td> <td>Only *, Δ, or ☼ can be selected</td> </tr> <tr> <td>Heat</td> <td>Only ✱ or ☼ can be selected</td> </tr> </tbody> </table> <p>▼ Model: SMMS-i The jumper lead is not switched. Indoor units in a mode other than the selected operation mode are forcibly switched to the selected operation mode.</p> <table border="1" data-bbox="558 1971 1260 2128"> <thead> <tr> <th>PC board selection mode</th> <th colspan="2">Remote control operation/display</th> </tr> </thead> <tbody> <tr> <td>Normal</td> <td>*, Δ, ✱, or ☼ can be selected</td> <td rowspan="3">When using the remote control, (mode select control) indicator is displayed.</td> </tr> <tr> <td>Cool</td> <td>Only *, Δ, or ☼ can be selected</td> </tr> <tr> <td>Heat</td> <td>Only ✱ or ☼ can be selected</td> </tr> </tbody> </table>	Input Signal		Operation: Selected operation mode	Cooling (SW1)	Heating (SW2)	ON	OFF	Cooling operation only	OFF	ON	Heating operation only	OFF	OFF	Normal operation	Jumper lead	Details of Processing			J01 connected (factory default)	Unallowed indoor units in a mode other than the selected operation mode are not treated as priority (thermo OFF state). (Unallowed indoor units)			Operation Mode	Operation State	Remote control indicator is displayed.	Cooling unit	Air blow operation at blow rate set on remote control	Heating unit	Air blow operation at super-slow blow rate	Air blow unit	Regular air blow operation at blow rate set on remote control		J01 cut	Indoor units in a mode other than the selected operation mode are forcibly switched to the selected operation mode.			PC board selection mode	Remote control operation/display		Normal	*, Δ, ✱, or ☼ can be selected	When using the remote control, (mode select control) indicator is displayed.	Cool	Only *, Δ, or ☼ can be selected	Heat	Only ✱ or ☼ can be selected	PC board selection mode	Remote control operation/display		Normal	*, Δ, ✱, or ☼ can be selected	When using the remote control, (mode select control) indicator is displayed.	Cool	Only *, Δ, or ☼ can be selected	Heat
Input Signal		Operation: Selected operation mode																																																							
Cooling (SW1)	Heating (SW2)																																																								
ON	OFF	Cooling operation only																																																							
OFF	ON	Heating operation only																																																							
OFF	OFF	Normal operation																																																							
Jumper lead	Details of Processing																																																								
J01 connected (factory default)	Unallowed indoor units in a mode other than the selected operation mode are not treated as priority (thermo OFF state). (Unallowed indoor units)																																																								
	Operation Mode	Operation State	Remote control indicator is displayed.																																																						
	Cooling unit	Air blow operation at blow rate set on remote control																																																							
	Heating unit	Air blow operation at super-slow blow rate																																																							
Air blow unit	Regular air blow operation at blow rate set on remote control																																																								
J01 cut	Indoor units in a mode other than the selected operation mode are forcibly switched to the selected operation mode.																																																								
	PC board selection mode	Remote control operation/display																																																							
	Normal	*, Δ, ✱, or ☼ can be selected	When using the remote control, (mode select control) indicator is displayed.																																																						
	Cool	Only *, Δ, or ☼ can be selected																																																							
Heat	Only ✱ or ☼ can be selected																																																								
PC board selection mode	Remote control operation/display																																																								
Normal	*, Δ, ✱, or ☼ can be selected	When using the remote control, (mode select control) indicator is displayed.																																																							
Cool	Only *, Δ, or ☼ can be selected																																																								
Heat	Only ✱ or ☼ can be selected																																																								

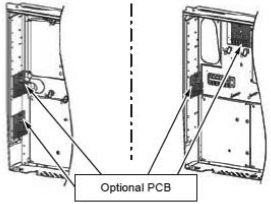

Model name	Appearance	Function																			
TCB-PCIN4E	 <p>Size: 73 x 79 (mm)</p>	<p>[6] Error / Operation Output</p> <ul style="list-style-type: none"> • Feature Operation and error monitoring is possible. ▼ Function The operation error output PCB can indicate operation and error states by connecting to the interface PCB of outdoor units. ▼ Operation Operation output: The operation indicator is on while any indoor unit in the system is operating. Error output: The error indicator is on when an error is occurred on even one of the indoor or outdoor units in the system. <p>Wiring example</p> 																			
	<p>Application</p>  <p>MMY-MAP080 to 120 MMY-MAP140, 160</p>  <p>Optional PCB</p> <p>(max. number installed: 2 pcs)</p> <p>* Install the optional PCB in the outdoor header unit.</p>	<table border="1"> <tr> <td>C1</td> <td>Attached connection cable 1 (4wires)</td> </tr> <tr> <td>CN511</td> <td>Connector on interface side (green)</td> </tr> <tr> <td>K1, K2</td> <td>Relays</td> </tr> <tr> <td>L1</td> <td>Error indication Lamp</td> </tr> <tr> <td>L2</td> <td>Operation indication Lamp</td> </tr> <tr> <td>OUTPUT1</td> <td>Error output</td> </tr> <tr> <td>OUTPUT2</td> <td>Operation output</td> </tr> <tr> <td>PJ20</td> <td>Connector on optional PCB side</td> </tr> <tr> <td>PS</td> <td>Power supply unit</td> </tr> <tr> <td>TB1</td> <td>Terminal block</td> </tr> </table> <p>* [OUTPUT3] is normally output when power is turned out.</p>	C1	Attached connection cable 1 (4wires)	CN511	Connector on interface side (green)	K1, K2	Relays	L1	Error indication Lamp	L2	Operation indication Lamp	OUTPUT1	Error output	OUTPUT2	Operation output	PJ20	Connector on optional PCB side	PS	Power supply unit	TB1
C1	Attached connection cable 1 (4wires)																				
CN511	Connector on interface side (green)																				
K1, K2	Relays																				
L1	Error indication Lamp																				
L2	Operation indication Lamp																				
OUTPUT1	Error output																				
OUTPUT2	Operation output																				
PJ20	Connector on optional PCB side																				
PS	Power supply unit																				
TB1	Terminal block																				

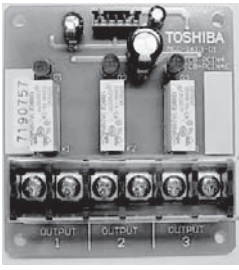
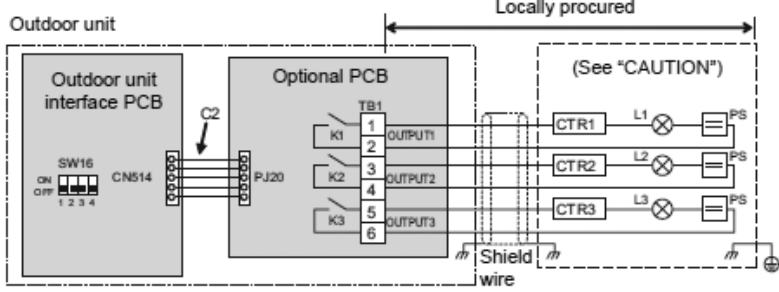
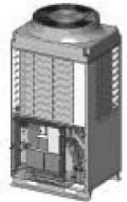
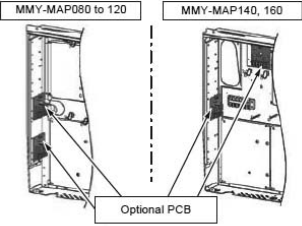

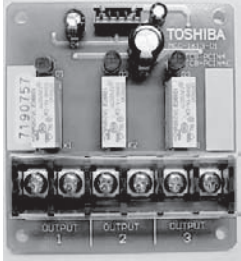
Model name	Appearance	Function																									
TCB-PCIN4E	 <p>Size: 73 x 79 (mm)</p>	<p>[7] Compressor Operation Output</p> <ul style="list-style-type: none"> • Feature Outputs the operation status of the compressors in each outdoor unit. ▼ Functions This function can be applied, for example, to the elapsed operation time count of each compressor mounted on an outdoor unit since the compressor in operation signal can be output externally. ▼ Operation During compressor operation, the relay of the output terminal corresponding to that compressor turns ON (closes) and turns OFF (opens) when compressor operation stops. As shown in the figure, the output terminals are "OUTPUT1", "OUTPUT2" and "OUTPUT3" from the left compressor facing the front of the outdoor unit. <p>Wiring example</p> 																									
	<p>Application</p>   <p>(max. number installed: 2 pcs)</p> <p>* Install the optional PCB in individual outdoor unit</p>	<table border="1"> <tbody> <tr> <td>C2</td> <td>Connector cable 2 (2)</td> </tr> <tr> <td>CN514</td> <td>Connector on interface side (green)</td> </tr> <tr> <td>CTR1</td> <td>Elapsed operation counter 1</td> </tr> <tr> <td>CTR2</td> <td>Elapsed operation counter 2</td> </tr> <tr> <td>CTR3</td> <td>Elapsed operation counter 3</td> </tr> <tr> <td>K1, K2, K3</td> <td>Relays</td> </tr> <tr> <td>L1, L2, L3</td> <td>Operation indication LEDs</td> </tr> <tr> <td>OUTPUT1</td> <td>Compressor 1 operation output terminal</td> </tr> <tr> <td>OUTPUT2</td> <td>Compressor 2 operation output terminal</td> </tr> <tr> <td>OUTPUT3</td> <td>Compressor 3 operation output terminal</td> </tr> <tr> <td>PJ20</td> <td>Connector on optional PCB side</td> </tr> <tr> <td>PS</td> <td>Power supply unit</td> </tr> <tr> <td>TB1</td> <td>Terminal block</td> </tr> </tbody> </table>	C2	Connector cable 2 (2)	CN514	Connector on interface side (green)	CTR1	Elapsed operation counter 1	CTR2	Elapsed operation counter 2	CTR3	Elapsed operation counter 3	K1, K2, K3	Relays	L1, L2, L3	Operation indication LEDs	OUTPUT1	Compressor 1 operation output terminal	OUTPUT2	Compressor 2 operation output terminal	OUTPUT3	Compressor 3 operation output terminal	PJ20	Connector on optional PCB side	PS	Power supply unit	TB1
C2	Connector cable 2 (2)																										
CN514	Connector on interface side (green)																										
CTR1	Elapsed operation counter 1																										
CTR2	Elapsed operation counter 2																										
CTR3	Elapsed operation counter 3																										
K1, K2, K3	Relays																										
L1, L2, L3	Operation indication LEDs																										
OUTPUT1	Compressor 1 operation output terminal																										
OUTPUT2	Compressor 2 operation output terminal																										
OUTPUT3	Compressor 3 operation output terminal																										
PJ20	Connector on optional PCB side																										
PS	Power supply unit																										
TB1	Terminal block																										

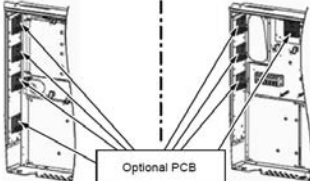
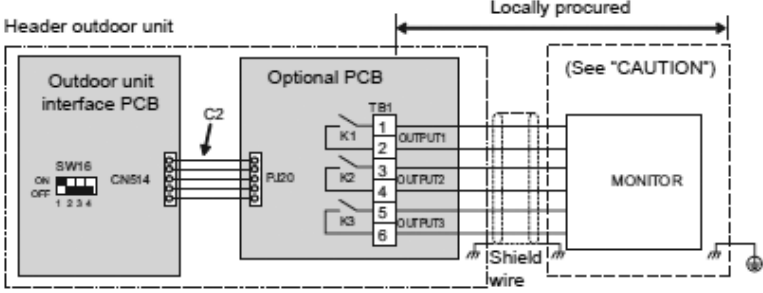
Model name	Appearance	Function																																															
TCB-PCIN4E	 <p>Size: 73 x 79 (mm)</p>	<p>[8] Operating Rate Output</p> <ul style="list-style-type: none"> • Feature Relay turn ON/OFF depending on the running rate of the system. <p>▼ Functions The operation state can be remotely checked since the system operating rate signal can be output externally.</p> <p>▼ Operation As shown in the table, each of the output terminals turns ON (relay closes) and OFF (relay opens) according to the system operating rate.</p> <table border="1" data-bbox="564 607 1430 864"> <thead> <tr> <th>Functions</th> <th>SW16</th> <th>OUTPUT1</th> <th>OUTPUT2</th> <th>OUTPUT3</th> <th>Operating rate FA</th> </tr> </thead> <tbody> <tr> <td rowspan="8">System operating rate output</td> <td>ON</td> <td>OFF</td> <td>OFF</td> <td>OFF</td> <td>FA=0%</td> </tr> <tr> <td>OFF</td> <td>ON</td> <td>OFF</td> <td>OFF</td> <td>0%<FA<20%</td> </tr> <tr> <td></td> <td>OFF</td> <td>ON</td> <td>OFF</td> <td>20%≤FA<35%</td> </tr> <tr> <td></td> <td>ON</td> <td>ON</td> <td>OFF</td> <td>35%≤FA<50%</td> </tr> <tr> <td></td> <td>OFF</td> <td>OFF</td> <td>ON</td> <td>50%≤FA<65%</td> </tr> <tr> <td></td> <td>ON</td> <td>OFF</td> <td>ON</td> <td>65%≤FA<80%</td> </tr> <tr> <td></td> <td>OFF</td> <td>ON</td> <td>ON</td> <td>80%≤FA<95%</td> </tr> <tr> <td></td> <td>ON</td> <td>ON</td> <td>ON</td> <td>95%≤FA</td> </tr> </tbody> </table> <p style="text-align: right;">OFF=relay open ON=relay closed</p>	Functions	SW16	OUTPUT1	OUTPUT2	OUTPUT3	Operating rate FA	System operating rate output	ON	OFF	OFF	OFF	FA=0%	OFF	ON	OFF	OFF	0%<FA<20%		OFF	ON	OFF	20%≤FA<35%		ON	ON	OFF	35%≤FA<50%		OFF	OFF	ON	50%≤FA<65%		ON	OFF	ON	65%≤FA<80%		OFF	ON	ON	80%≤FA<95%		ON	ON	ON	95%≤FA
	Functions	SW16	OUTPUT1	OUTPUT2	OUTPUT3	Operating rate FA																																											
	System operating rate output	ON	OFF	OFF	OFF	FA=0%																																											
OFF		ON	OFF	OFF	0%<FA<20%																																												
		OFF	ON	OFF	20%≤FA<35%																																												
		ON	ON	OFF	35%≤FA<50%																																												
		OFF	OFF	ON	50%≤FA<65%																																												
		ON	OFF	ON	65%≤FA<80%																																												
		OFF	ON	ON	80%≤FA<95%																																												
		ON	ON	ON	95%≤FA																																												
<p style="text-align: center;">Application</p>  <div style="display: flex; justify-content: space-around;"> <div data-bbox="217 1223 363 1245">MMY-MAP080 to 120</div> <div data-bbox="392 1223 539 1245">MMY-MAP140, 160</div> </div>  <p>(max. number installed: 4 pcs)</p> <p>* Install the optional PCB in the outdoor header unit.</p>	<p>Wiring example</p>  <table border="1" data-bbox="564 1256 1430 1514"> <tbody> <tr> <td>C2</td> <td>Connector cable 2 (2)</td> </tr> <tr> <td>CN514</td> <td>Connector on interface side (green)</td> </tr> <tr> <td>K1, K2, K3</td> <td>Relays</td> </tr> <tr> <td>MONITOR</td> <td>Monitoring device</td> </tr> <tr> <td>OUTPUT1</td> <td>Output terminal for each function</td> </tr> <tr> <td>OUTPUT2</td> <td>Output terminal for each function</td> </tr> <tr> <td>OUTPUT3</td> <td>Output terminal for each function</td> </tr> <tr> <td>PJ20</td> <td>Connector on optional PCB side</td> </tr> <tr> <td>TB1</td> <td>Terminal block</td> </tr> </tbody> </table>	C2	Connector cable 2 (2)	CN514	Connector on interface side (green)	K1, K2, K3	Relays	MONITOR	Monitoring device	OUTPUT1	Output terminal for each function	OUTPUT2	Output terminal for each function	OUTPUT3	Output terminal for each function	PJ20	Connector on optional PCB side	TB1	Terminal block																														
C2	Connector cable 2 (2)																																																
CN514	Connector on interface side (green)																																																
K1, K2, K3	Relays																																																
MONITOR	Monitoring device																																																
OUTPUT1	Output terminal for each function																																																
OUTPUT2	Output terminal for each function																																																
OUTPUT3	Output terminal for each function																																																
PJ20	Connector on optional PCB side																																																
TB1	Terminal block																																																



TCB-PCDM4E

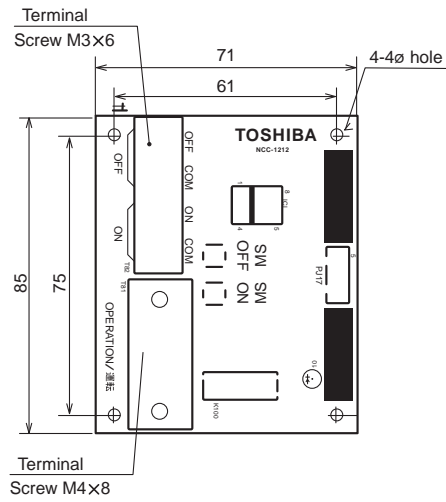

TCB-PCMO4E

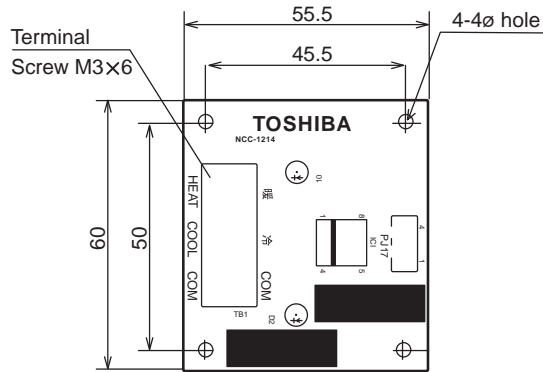

TCB-PCIN4E

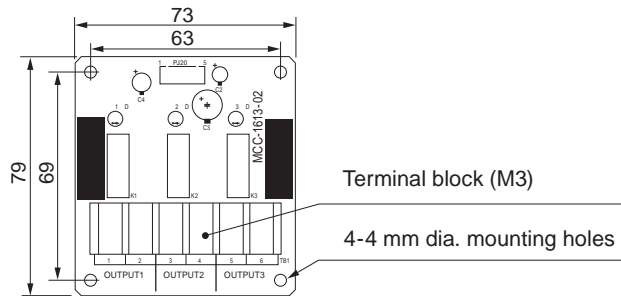



5-10. Part load performance

Single unit

MMY-MAP0804HT8P-E, MAP0804T8P-E (8HP, 22.4 kW system)

Cooling

Outdoor Unit Dry-Bulb (°C)		Outdoor Unit 100 % Cooling Capacity (kW)	Compressor + Outdoor Fan Power consumption (kW)							
			100 %		90 %		80 %		70 %	
			TC (kW)	PI (kW)	TC (kW)	PI (kW)	TC (kW)	PI (kW)	TC (kW)	PI (kW)
40	20.8	20.8	5.83	18.8	4.79	16.7	3.89	14.6	3.11	
39	21.2	21.2	5.75	19.1	4.72	17.0	3.83	14.8	3.06	
37	21.8	21.8	5.57	19.6	4.58	17.4	3.71	15.3	2.97	
35	22.4	22.4	5.40	20.2	4.44	17.9	3.60	15.7	2.87	
33	22.4	22.4	4.99	20.2	4.11	17.9	3.34	15.7	2.68	
31	22.4	22.4	4.63	20.2	3.82	17.9	3.11	15.7	2.50	
30	22.4	22.4	4.46	20.2	3.68	17.9	3.00	15.7	2.42	
29	22.4	22.4	4.31	20.2	3.56	17.9	2.90	15.7	2.34	
27	22.4	22.4	4.02	20.2	3.32	17.9	2.71	15.7	2.19	
25	22.4	22.4	3.75	20.2	3.10	17.9	2.54	15.7	2.06	
23	22.4	22.4	3.50	20.2	2.90	17.9	2.38	15.7	1.93	
21	22.4	22.4	3.43	20.2	2.84	17.9	2.33	15.7	1.90	
20	22.4	22.4	3.40	20.2	2.82	17.9	2.31	15.7	1.88	
19	22.4	22.4	3.36	20.2	2.79	17.9	2.29	15.7	1.87	
17	22.4	22.4	3.31	20.2	2.75	17.9	2.26	15.7	1.84	
15	22.4	22.4	3.26	20.2	2.71	17.9	2.23	15.7	1.82	

Outdoor Unit Dry-Bulb (°C)		Outdoor Unit 100 % Cooling Capacity (kW)	Compressor + Outdoor Fan Power consumption (kW)							
			60 %		50 %		40 %		30 %	
			TC (kW)	PI (kW)	TC (kW)	PI (kW)	TC (kW)	PI (kW)	TC (kW)	PI (kW)
40	20.8	12.5	2.46	10.4	1.94	8.34	1.55	6.25	1.29	
39	21.2	12.7	2.42	10.6	1.91	8.48	1.52	6.36	1.27	
37	21.8	13.1	2.35	10.9	1.85	8.72	1.48	6.54	1.23	
35	22.4	13.4	2.27	11.2	1.79	8.96	1.43	6.72	1.19	
33	22.4	13.4	2.13	11.2	1.69	8.96	1.36	6.72	1.14	
31	22.4	13.4	1.99	11.2	1.59	8.96	1.29	6.72	1.09	
30	22.4	13.4	1.93	11.2	1.54	8.96	1.26	6.72	1.07	
29	22.4	13.4	1.87	11.2	1.50	8.96	1.22	6.72	1.04	
27	22.4	13.4	1.76	11.2	1.42	8.96	1.16	6.72	1.00	
25	22.4	13.4	1.66	11.2	1.34	8.96	1.10	6.72	0.95	
23	22.4	13.4	1.56	11.2	1.27	8.96	1.05	6.72	0.91	
21	22.4	13.4	1.54	11.2	1.25	8.96	1.04	6.72	0.90	
20	22.4	13.4	1.53	11.2	1.24	8.96	1.04	6.72	0.90	
19	22.4	13.4	1.52	11.2	1.24	8.96	1.03	6.72	0.90	
17	22.4	13.4	1.50	11.2	1.23	8.96	1.03	6.72	0.90	
15	22.4	13.4	1.48	11.2	1.22	8.96	1.02	6.72	0.89	

TC : Total Capacity PI : Power Input
Indoor air temperature conditions : 27.0 °C dry-bulb / 19.0 °C wet bulb

Heating

Outdoor Unit Dry-Bulb (°C)		Outdoor Unit Wet-Bulb (°C)	Outdoor Unit 100 % Heating Capacity (kW)	Compressor + Outdoor Fan Power consumption (kW)							
				100 %		90 %		80 %		70 %	
				TC (kW)	PI (kW)	TC (kW)	PI (kW)	TC (kW)	PI (kW)	TC (kW)	PI (kW)
15.0	13.7	25.0	25.0	4.60	22.5	3.82	20.0	3.18	17.5	2.65	
13.0	11.8	25.0	25.0	4.78	22.5	3.95	20.0	3.26	17.5	2.70	
11.0	9.8	25.0	25.0	5.00	22.5	4.11	20.0	3.37	17.5	2.78	
9.0	7.9	25.0	25.0	5.25	22.5	4.28	20.0	3.49	17.5	2.85	
7.0	6.0	25.0	25.0	5.53	22.5	4.48	20.0	3.63	17.5	2.95	
5.0	4.1	24.2	24.2	5.44	21.7	4.41	19.3	3.57	16.9	2.90	
3.0	2.2	23.3	23.3	5.36	21.0	4.34	18.6	3.52	16.3	2.86	
0.0	-0.7	21.9	21.9	5.23	19.7	4.24	17.5	3.43	15.4	2.79	
-3.0	-3.7	20.5	20.5	5.10	18.4	4.13	16.4	3.35	14.3	2.72	
-5.0	-5.6	19.6	19.6	5.02	17.6	4.06	15.6	3.29	13.7	2.67	
-7.0	-7.6	18.6	18.6	4.93	16.7	3.99	14.8	3.23	13.0	2.63	
-10	-10.5	17.1	17.1	4.80	15.4	3.89	13.7	3.15	12.0	2.56	
-14.5	-15.0	14.7	14.7	4.60	13.2	3.73	11.8	3.02	10.3	2.45	

Outdoor Unit Dry-Bulb (°C)		Outdoor Unit Wet-Bulb (°C)	Outdoor Unit 100 % Heating Capacity (kW)	Compressor + Outdoor Fan Power consumption (kW)							
				60 %		50 %		40 %		30 %	
				TC (kW)	PI (kW)	TC (kW)	PI (kW)	TC (kW)	PI (kW)	TC (kW)	PI (kW)
15.0	13.7	25.0	15.0	2.21	12.5	1.83	10.0	1.51	7.50	1.20	
13.0	11.8	25.0	15.0	2.24	12.5	1.86	10.0	1.52	7.50	1.21	
11.0	9.8	25.0	15.0	2.29	12.5	1.88	10.0	1.54	7.50	1.22	
9.0	7.9	25.0	15.0	2.34	12.5	1.92	10.0	1.55	7.50	1.23	
7.0	6.0	25.0	15.0	2.40	12.5	1.95	10.0	1.58	7.50	1.24	
5.0	4.1	24.2	14.5	2.36	12.1	1.92	9.66	1.55	7.25	1.22	
3.0	2.2	23.3	14.0	2.32	11.6	1.89	9.31	1.53	6.99	1.20	
0.0	-0.7	21.9	13.2	2.27	11.0	1.85	8.77	1.49	6.58	1.17	
-3.0	-3.7	20.5	12.3	2.21	10.2	1.80	8.20	1.45	6.15	1.14	
-5.0	-5.6	19.6	11.7	2.17	9.78	1.77	7.82	1.43	5.87	1.13	
-7.0	-7.6	18.6	11.1	2.14	9.28	1.74	7.42	1.40	5.57	1.11	
-10	-10.5	17.1	10.2	2.08	8.54	1.69	6.83	1.37	5.12	1.08	
-14.5	-15.0	14.7	8.82	1.99	7.35	1.62	5.88	1.31	4.41	1.03	

TC : Total Capacity PI : Power Input
Indoor air temperature conditions : 20.0 °C dry-bulb



MMY-MAP1004HT8P-E, MAP1004T8P-E (10HP, 28 kW system)

Cooling

Outdoor Unit Dry-Bulb (°C)	Outdoor Unit 100 % Cooling Capacity (kW)	Compressor + Outdoor Fan Power consumption (kW)							
		100 %		90 %		80 %		70 %	
		TC (kW)	PI (kW)	TC (kW)	PI (kW)	TC (kW)	PI (kW)	TC (kW)	PI (kW)
40	26.1	26.1	8.00	23.5	6.58	20.8	5.33	18.2	4.26
39	26.5	26.5	7.88	23.8	6.48	21.2	5.25	18.5	4.20
37	27.3	27.3	7.65	24.5	6.28	21.8	5.09	19.1	4.07
35	28.0	28.0	7.41	25.2	6.09	22.4	4.93	19.6	3.95
33	28.0	28.0	6.85	25.2	5.64	22.4	4.58	19.6	3.67
31	28.0	28.0	6.35	25.2	5.24	22.4	4.26	19.6	3.43
30	28.0	28.0	6.13	25.2	5.06	22.4	4.12	19.6	3.32
29	28.0	28.0	5.91	25.2	4.88	22.4	3.98	19.6	3.21
27	28.0	28.0	5.51	25.2	4.56	22.4	3.72	19.6	3.01
25	28.0	28.0	5.14	25.2	4.26	22.4	3.48	19.6	2.82
23	28.0	28.0	4.81	25.2	3.98	22.4	3.26	19.6	2.65
21	28.0	28.0	4.71	25.2	3.90	22.4	3.20	19.6	2.60
20	28.0	28.0	4.66	25.2	3.87	22.4	3.17	19.6	2.58
19	28.0	28.0	4.62	25.2	3.83	22.4	3.15	19.6	2.56
17	28.0	28.0	4.54	25.2	3.77	22.4	3.10	19.6	2.53
15	28.0	28.0	4.48	25.2	3.72	22.4	3.06	19.6	2.50

Outdoor Unit Dry-Bulb (°C)	Outdoor Unit 100 % Cooling Capacity (kW)	Compressor + Outdoor Fan Power consumption (kW)							
		60 %		50 %		40 %		30 %	
		TC (kW)	PI (kW)	TC (kW)	PI (kW)	TC (kW)	PI (kW)	TC (kW)	PI (kW)
40	26.1	15.6	3.37	13.0	2.66	10.42	2.12	7.82	1.76
39	26.5	15.9	3.32	13.2	2.62	10.59	2.09	7.94	1.74
37	27.3	16.4	3.22	13.6	2.54	10.91	2.03	8.18	1.69
35	28.0	16.8	3.12	14.0	2.46	11.20	1.96	8.40	1.63
33	28.0	16.8	2.92	14.0	2.31	11.20	1.86	8.40	1.56
31	28.0	16.8	2.74	14.0	2.18	11.20	1.77	8.40	1.49
30	28.0	16.8	2.65	14.0	2.12	11.20	1.72	8.40	1.46
29	28.0	16.8	2.57	14.0	2.06	11.20	1.68	8.40	1.43
27	28.0	16.8	2.42	14.0	1.95	11.20	1.60	8.40	1.37
25	28.0	16.8	2.27	14.0	1.84	11.20	1.51	8.40	1.30
23	28.0	16.8	2.14	14.0	1.74	11.20	1.44	8.40	1.24
21	28.0	16.8	2.11	14.0	1.72	11.20	1.43	8.40	1.24
20	28.0	16.8	2.09	14.0	1.71	11.20	1.42	8.40	1.24
19	28.0	16.8	2.08	14.0	1.70	11.20	1.42	8.40	1.23
17	28.0	16.8	2.06	14.0	1.68	11.20	1.41	8.40	1.23
15	28.0	16.8	2.04	14.0	1.67	11.20	1.40	8.40	1.23

TC : Total Capacity PI : Power Input
Indoor air temperature conditions : 27.0 °C dry-bulb / 19.0 °C wet bulb

Heating

Outdoor Unit		Outdoor Unit 100 % Heating Capacity (kW)	Compressor + Outdoor Fan Power consumption (kW)							
Dry-Bulb (°C)	Wet-Bulb (°C)		100 %		90 %		80 %		70 %	
(°C)	(°C)		TC (kW)	PI (kW)	TC (kW)	PI (kW)	TC (kW)	PI (kW)	TC (kW)	PI (kW)
15.0	13.7	31.5	31.5	6.24	28.4	5.18	25.2	4.31	22.1	3.59
13.0	11.8	31.5	31.5	6.49	28.4	5.36	25.2	4.43	22.1	3.67
11.0	9.8	31.5	31.5	6.79	28.4	5.57	25.2	4.57	22.1	3.76
9.0	7.9	31.5	31.5	7.12	28.4	5.80	25.2	4.73	22.1	3.87
7.0	6.0	31.5	31.5	7.50	28.4	6.08	25.2	4.92	22.1	4.00
5.0	4.1	30.4	30.4	7.38	27.4	5.98	24.3	4.85	21.3	3.93
3.0	2.2	29.3	29.3	7.27	26.4	5.89	23.5	4.77	20.5	3.87
0.0	-0.7	27.6	27.6	7.10	24.9	5.75	22.1	4.66	19.3	3.78
-3.0	-3.7	25.8	25.8	6.92	23.2	5.60	20.7	4.54	18.1	3.68
-5.0	-5.6	24.6	24.6	6.80	22.2	5.51	19.7	4.47	17.3	3.62
-7.0	-7.6	23.4	23.4	6.68	21.0	5.41	18.7	4.39	16.4	3.56
-10	-10.5	21.5	21.5	6.51	19.4	5.27	17.2	4.27	15.1	3.47
-14.5	-15.0	18.5	18.5	6.24	16.7	5.05	14.8	4.10	13.0	3.32

Outdoor Unit		Outdoor Unit 100 % Heating Capacity (kW)	Compressor + Outdoor Fan Power consumption (kW)							
Dry-Bulb (°C)	Wet-Bulb (°C)		60 %		50 %		40 %		30 %	
(°C)	(°C)		TC (kW)	PI (kW)	TC (kW)	PI (kW)	TC (kW)	PI (kW)	TC (kW)	PI (kW)
15.0	13.7	31.5	18.9	2.99	15.8	2.49	12.6	2.04	9.45	1.62
13.0	11.8	31.5	18.9	3.04	15.8	2.52	12.6	2.06	9.45	1.63
11.0	9.8	31.5	18.9	3.10	15.8	2.56	12.6	2.08	9.45	1.65
9.0	7.9	31.5	18.9	3.17	15.8	2.60	12.6	2.11	9.45	1.66
7.0	6.0	31.5	18.9	3.25	15.8	2.65	12.6	2.14	9.45	1.68
5.0	4.1	30.4	18.3	3.20	15.2	2.61	12.2	2.10	9.13	1.66
3.0	2.2	29.3	17.6	3.15	14.7	2.57	11.7	2.07	8.80	1.63
0.0	-0.7	27.6	16.6	3.08	13.8	2.50	11.1	2.02	8.29	1.59
-3.0	-3.7	25.8	15.5	3.00	12.9	2.44	10.3	1.97	7.75	1.55
-5.0	-5.6	24.6	14.8	2.95	12.3	2.40	9.86	1.94	7.39	1.53
-7.0	-7.6	23.4	14.0	2.90	11.7	2.36	9.35	1.90	7.01	1.50
-10	-10.5	21.5	12.9	2.82	10.8	2.30	8.61	1.86	6.45	1.46
-14.5	-15.0	18.5	11.1	2.70	9.26	2.20	7.41	1.78	5.55	1.40

TC : Total Capacity PI : Power Input
Indoor air temperature conditions : 20.0 °C dry-bulb



MMY-MAP1204HT8P-E, MAP1204T8P-E (12HP, 33.5 kW system)

Cooling

Outdoor Unit Dry-Bulb (°C)		Outdoor Unit 100 % Cooling Capacity (kW)	Compressor + Outdoor Fan Power consumption (kW)							
			100 %		90 %		80 %		70 %	
			TC (kW)	PI (kW)	TC (kW)	PI (kW)	TC (kW)	PI (kW)	TC (kW)	PI (kW)
40	31.2	31.2	10.3	28.1	8.41	24.9	6.76	21.8	5.36	
39	31.7	31.7	10.2	28.5	8.28	25.3	6.66	22.2	5.28	
37	32.6	32.6	9.85	29.4	8.03	26.1	6.45	22.8	5.12	
35	33.5	33.5	9.55	30.2	7.78	26.8	6.25	23.5	4.96	
33	33.5	33.5	8.81	30.2	7.19	26.8	5.79	23.5	4.61	
31	33.5	33.5	8.16	30.2	6.67	26.8	5.39	23.5	4.30	
30	33.5	33.5	7.86	30.2	6.43	26.8	5.20	23.5	4.16	
29	33.5	33.5	7.58	30.2	6.21	26.8	5.02	23.5	4.02	
27	33.5	33.5	7.05	30.2	5.79	26.8	4.69	23.5	3.77	
25	33.5	33.5	6.58	30.2	5.40	26.8	4.39	23.5	3.53	
23	33.5	33.5	6.14	30.2	5.05	26.8	4.11	23.5	3.31	
21	33.5	33.5	6.01	30.2	4.94	26.8	4.03	23.5	3.25	
20	33.5	33.5	5.94	30.2	4.90	26.8	3.99	23.5	3.23	
19	33.5	33.5	5.89	30.2	4.85	26.8	3.96	23.5	3.20	
17	33.5	33.5	5.79	30.2	4.77	26.8	3.90	23.5	3.16	
15	33.5	33.5	5.70	30.2	4.71	26.8	3.85	23.5	3.12	

Outdoor Unit Dry-Bulb (°C)		Outdoor Unit 100 % Cooling Capacity (kW)	Compressor + Outdoor Fan Power consumption (kW)							
			60 %		50 %		40 %		30 %	
			TC (kW)	PI (kW)	TC (kW)	PI (kW)	TC (kW)	PI (kW)	TC (kW)	PI (kW)
40	31.2	18.7	4.21	15.6	3.30	12.5	2.63	9.35	2.20	
39	31.7	19.0	4.15	15.8	3.25	12.67	2.59	9.50	2.16	
37	32.6	19.6	4.02	16.3	3.15	13.05	2.51	9.79	2.10	
35	33.5	20.1	3.89	16.8	3.05	13.40	2.44	10.05	2.03	
33	33.5	20.1	3.64	16.8	2.87	13.40	2.31	10.05	1.94	
31	33.5	20.1	3.41	16.8	2.71	13.40	2.19	10.05	1.86	
30	33.5	20.1	3.30	16.8	2.63	13.40	2.14	10.05	1.82	
29	33.5	20.1	3.20	16.8	2.55	13.40	2.08	10.05	1.78	
27	33.5	20.1	3.01	16.8	2.41	13.40	1.98	10.05	1.70	
25	33.5	20.1	2.83	16.8	2.28	13.40	1.88	10.05	1.63	
23	33.5	20.1	2.66	16.8	2.15	13.40	1.78	10.05	1.55	
21	33.5	20.1	2.62	16.8	2.13	13.40	1.77	10.05	1.55	
20	33.5	20.1	2.60	16.8	2.12	13.40	1.76	10.05	1.54	
19	33.5	20.1	2.59	16.8	2.11	13.40	1.76	10.05	1.54	
17	33.5	20.1	2.56	16.8	2.09	13.40	1.75	10.05	1.54	
15	33.5	20.1	2.53	16.8	2.07	13.40	1.74	10.05	1.53	

TC : Total Capacity PI : Power Input
Indoor air temperature conditions : 27.0 °C dry-bulb / 19.0 °C wet bulb

Heating

Outdoor Unit Dry-Bulb (°C)		Outdoor Unit Wet-Bulb (°C)	Outdoor Unit 100 % Heating Capacity (kW)	Compressor + Outdoor Fan Power consumption (kW)							
				100 %		90 %		80 %		70 %	
				TC (kW)	PI (kW)	TC (kW)	PI (kW)	TC (kW)	PI (kW)	TC (kW)	PI (kW)
15.0	13.7	37.5	37.5	8.51	33.8	7.04	30.0	5.80	26.3	4.78	
13.0	11.8	37.5	37.5	8.85	33.8	7.29	30.0	5.98	26.3	4.90	
11.0	9.8	37.5	37.5	9.25	33.8	7.59	30.0	6.19	26.3	5.04	
9.0	7.9	37.5	37.5	9.69	33.8	7.91	30.0	6.42	26.3	5.20	
7.0	6.0	37.5	37.5	10.2	33.8	8.29	30.0	6.69	26.3	5.38	
5.0	4.1	36.2	36.2	10.0	32.6	8.16	29.0	6.59	25.4	5.30	
3.0	2.2	34.9	34.9	9.89	31.4	8.03	27.9	6.49	24.4	5.21	
0.0	-0.7	32.9	32.9	9.65	29.6	7.84	26.3	6.33	23.0	5.09	
-3.0	-3.7	30.7	30.7	9.41	27.7	7.64	24.6	6.17	21.5	4.96	
-5.0	-5.6	29.3	29.3	9.25	26.4	7.52	23.5	6.07	20.5	4.88	
-7.0	-7.6	27.8	27.8	9.09	25.1	7.38	22.3	5.96	19.5	4.79	
-10	-10.5	25.6	25.6	8.85	23.0	7.19	20.5	5.81	17.9	4.67	
-14.5	-15.0	22.0	22.0	8.49	19.8	6.89	17.6	5.57	15.4	4.47	

Outdoor Unit Dry-Bulb (°C)		Outdoor Unit Wet-Bulb (°C)	Outdoor Unit 100 % Heating Capacity (kW)	Compressor + Outdoor Fan Power consumption (kW)							
				60 %		50 %		40 %		30 %	
				TC (kW)	PI (kW)	TC (kW)	PI (kW)	TC (kW)	PI (kW)	TC (kW)	PI (kW)
15.0	13.7	37.5	22.5	3.93	18.8	3.25	15.0	2.70	11.3	2.27	
13.0	11.8	37.5	22.5	4.01	18.8	3.29	15.0	2.72	11.3	2.27	
11.0	9.8	37.5	22.5	4.10	18.8	3.34	15.0	2.74	11.3	2.27	
9.0	7.9	37.5	22.5	4.20	18.8	3.40	15.0	2.77	11.3	2.28	
7.0	6.0	37.5	22.5	4.32	18.8	3.47	15.0	2.80	11.3	2.28	
5.0	4.1	36.2	21.7	4.25	18.1	3.42	14.5	2.76	10.9	2.25	
3.0	2.2	34.9	21.0	4.18	17.5	3.36	14.0	2.72	10.5	2.22	
0.0	-0.7	32.9	19.7	4.08	16.4	3.28	13.2	2.65	9.87	2.16	
-3.0	-3.7	30.7	18.4	3.98	15.4	3.20	12.3	2.58	9.22	2.11	
-5.0	-5.6	29.3	17.6	3.91	14.67	3.15	11.7	2.54	8.80	2.07	
-7.0	-7.6	27.8	16.7	3.85	13.92	3.09	11.1	2.50	8.35	2.04	
-10	-10.5	25.6	15.4	3.75	12.81	3.01	10.2	2.43	7.68	1.98	
-14.5	-15.0	22.0	13.2	3.59	11.02	2.89	8.82	2.33	6.61	1.90	

TC : Total Capacity PI : Power Input
Indoor air temperature conditions : 20.0 °C dry-bulb



MMY-MAP1404HT8P-E, MAP1404T8P-E (14HP, 40 kW system)

Cooling

Outdoor Unit Dry-Bulb (°C)		Outdoor Unit 100 % Cooling Capacity (kW)	Compressor + Outdoor Fan Power consumption (kW)							
			100 %		90 %		80 %		70 %	
			TC (kW)	PI (kW)	TC (kW)	PI (kW)	TC (kW)	PI (kW)	TC (kW)	PI (kW)
40	37.2	37.2	12.4	33.5	10.1	29.8	8.14	26.1	6.40	
39	37.8	37.8	12.2	34.0	10.00	30.3	8.01	26.5	6.30	
37	39.0	39.0	11.9	35.1	9.70	31.2	7.77	27.3	6.11	
35	40.0	40.0	11.5	36.0	9.39	32.0	7.53	28.0	5.92	
33	40.0	40.0	10.6	36.0	8.68	32.0	6.97	28.0	5.49	
31	40.0	40.0	9.84	36.0	8.05	32.0	6.47	28.0	5.12	
30	40.0	40.0	9.48	36.0	7.76	32.0	6.24	28.0	4.94	
29	40.0	40.0	9.15	36.0	7.49	32.0	6.03	28.0	4.77	
27	40.0	40.0	8.52	36.0	6.98	32.0	5.62	28.0	4.46	
25	40.0	40.0	7.94	36.0	6.51	32.0	5.25	28.0	4.18	
23	40.0	40.0	7.42	36.0	6.08	32.0	4.91	28.0	3.92	
21	40.0	40.0	7.25	36.0	5.95	32.0	4.81	28.0	3.84	
20	40.0	40.0	7.18	36.0	5.89	32.0	4.77	28.0	3.81	
19	40.0	40.0	7.11	36.0	5.84	32.0	4.73	28.0	3.78	
17	40.0	40.0	6.99	36.0	5.74	32.0	4.65	28.0	3.72	
15	40.0	40.0	6.88	36.0	5.66	32.0	4.59	28.0	3.68	

Outdoor Unit Dry-Bulb (°C)		Outdoor Unit 100 % Cooling Capacity (kW)	Compressor + Outdoor Fan Power consumption (kW)							
			60 %		50 %		40 %		30 %	
			TC (kW)	PI (kW)	TC (kW)	PI (kW)	TC (kW)	PI (kW)	TC (kW)	PI (kW)
40	37.2	22.3	4.95	18.6	3.82	14.9	3.02	11.2	2.57	
39	37.8	22.7	4.88	18.9	3.77	15.1	2.98	11.3	2.54	
37	39.0	23.4	4.73	19.5	3.65	15.6	2.89	11.7	2.46	
35	40.0	24.0	4.58	20.0	3.54	16.0	2.80	12.0	2.38	
33	40.0	24.0	4.27	20.0	3.32	16.0	2.65	12.0	2.29	
31	40.0	24.0	4.00	20.0	3.13	16.0	2.52	12.0	2.19	
30	40.0	24.0	3.87	20.0	3.03	16.0	2.46	12.0	2.15	
29	40.0	24.0	3.74	20.0	2.95	16.0	2.40	12.0	2.11	
27	40.0	24.0	3.51	20.0	2.78	16.0	2.28	12.0	2.02	
25	40.0	24.0	3.30	20.0	2.63	16.0	2.17	12.0	1.93	
23	40.0	24.0	3.10	20.0	2.48	16.0	2.06	12.0	1.85	
21	40.0	24.0	3.05	20.0	2.45	16.0	2.04	12.0	1.84	
20	40.0	24.0	3.03	20.0	2.43	16.0	2.04	12.0	1.84	
19	40.0	24.0	3.01	20.0	2.42	16.0	2.03	12.0	1.84	
17	40.0	24.0	2.97	20.0	2.40	16.0	2.02	12.0	1.84	
15	40.0	24.0	2.94	20.0	2.38	16.0	2.01	12.0	1.84	

TC : Total Capacity PI : Power Input
Indoor air temperature conditions : 27.0 °C dry-bulb / 19.0 °C wet bulb

Heating

Outdoor Unit Dry-Bulb (°C)		Outdoor Unit Wet-Bulb (°C)	Outdoor Unit 100 % Heating Capacity (kW)	Compressor + Outdoor Fan Power consumption (kW)							
				100 %		90 %		80 %		70 %	
				TC (kW)	PI (kW)	TC (kW)	PI (kW)	TC (kW)	PI (kW)	TC (kW)	PI (kW)
15.0	13.7	45.0	45.0	9.32	40.5	7.74	36.0	6.43	31.5	5.36	
13.0	11.8	45.0	45.0	9.69	40.5	8.00	36.0	6.61	31.5	5.48	
11.0	9.8	45.0	45.0	10.1	40.5	8.31	36.0	6.83	31.5	5.62	
9.0	7.9	45.0	45.0	10.6	40.5	8.67	36.0	7.07	31.5	5.78	
7.0	6.0	45.0	45.0	11.2	40.5	9.07	36.0	7.35	31.5	5.97	
5.0	4.1	43.5	43.5	11.0	39.1	8.93	34.8	7.24	30.4	5.87	
3.0	2.2	41.9	41.9	10.9	37.7	8.80	33.5	7.13	29.3	5.78	
0.0	-0.7	39.5	39.5	10.6	35.5	8.59	31.6	6.96	27.6	5.65	
-3.0	-3.7	36.9	36.9	10.3	33.2	8.37	29.5	6.78	25.8	5.50	
-5.0	-5.6	35.2	35.2	10.2	31.7	8.23	28.2	6.67	24.6	5.41	
-7.0	-7.6	33.4	33.4	9.98	30.1	8.09	26.7	6.55	23.4	5.32	
-10	-10.5	30.7	30.7	9.72	27.7	7.88	24.6	6.38	21.5	5.18	
-14.5	-15.0	26.4	26.4	9.32	23.8	7.55	21.2	6.12	18.5	4.96	

Outdoor Unit Dry-Bulb (°C)		Outdoor Unit Wet-Bulb (°C)	Outdoor Unit 100 % Heating Capacity (kW)	Compressor + Outdoor Fan Power consumption (kW)							
				60 %		50 %		40 %		30 %	
				TC (kW)	PI (kW)	TC (kW)	PI (kW)	TC (kW)	PI (kW)	TC (kW)	PI (kW)
15.0	13.7	45.0	27.0	4.47	22.5	3.71	18.0	3.05	13.5	2.42	
13.0	11.8	45.0	27.0	4.54	22.5	3.76	18.0	3.08	13.5	2.44	
11.0	9.8	45.0	27.0	4.64	22.5	3.82	18.0	3.11	13.5	2.46	
9.0	7.9	45.0	27.0	4.74	22.5	3.88	18.0	3.15	13.5	2.49	
7.0	6.0	45.0	27.0	4.85	22.5	3.95	18.0	3.19	13.5	2.51	
5.0	4.1	43.5	26.1	4.78	21.7	3.89	17.4	3.14	13.0	2.47	
3.0	2.2	41.9	25.1	4.71	21.0	3.83	16.8	3.09	12.6	2.44	
0.0	-0.7	39.5	23.7	4.59	19.7	3.74	15.8	3.02	11.8	2.38	
-3.0	-3.7	36.9	22.1	4.48	18.4	3.64	14.8	2.94	11.1	2.32	
-5.0	-5.6	35.2	21.1	4.40	17.6	3.58	14.1	2.90	10.6	2.28	
-7.0	-7.6	33.4	20.0	4.33	16.7	3.52	13.4	2.84	10.0	2.24	
-10	-10.5	30.7	18.4	4.21	15.4	3.43	12.3	2.77	9.22	2.18	
-14.5	-15.0	26.4	15.9	4.04	13.2	3.29	10.6	2.66	7.93	2.09	

TC : Total Capacity PI : Power Input
Indoor air temperature conditions : 20.0 °C dry-bulb



MMY-MAP1604HT8P-E, MAP1604T8P-E (16HP, 45 kW system)

Cooling

Outdoor Unit Dry-Bulb (°C)		Outdoor Unit 100 % Cooling Capacity (kW)	Compressor + Outdoor Fan Power consumption (kW)							
			100 %		90 %		80 %		70 %	
			TC (kW)	PI (kW)	TC (kW)	PI (kW)	TC (kW)	PI (kW)	TC (kW)	PI (kW)
40	41.9	41.9	14.8	37.7	12.1	33.5	9.69	29.3	7.54	
39	42.5	42.5	14.6	38.3	11.9	34.0	9.55	29.8	7.43	
37	43.8	43.8	14.1	39.4	11.6	35.1	9.26	30.7	7.21	
35	45.0	45.0	13.7	40.5	11.2	36.0	8.97	31.5	6.98	
33	45.0	45.0	12.7	40.5	10.4	36.0	8.29	31.5	6.46	
31	45.0	45.0	11.7	40.5	9.62	36.0	7.69	31.5	6.00	
30	45.0	45.0	11.3	40.5	9.27	36.0	7.41	31.5	5.79	
29	45.0	45.0	10.9	40.5	8.94	36.0	7.15	31.5	5.59	
27	45.0	45.0	10.2	40.5	8.33	36.0	6.66	31.5	5.22	
25	45.0	45.0	9.49	40.5	7.77	36.0	6.22	31.5	4.88	
23	45.0	45.0	8.86	40.5	7.25	36.0	5.81	31.5	4.56	
21	45.0	45.0	8.66	40.5	7.09	36.0	5.68	31.5	4.47	
20	45.0	45.0	8.58	40.5	7.02	36.0	5.63	31.5	4.43	
19	45.0	45.0	8.49	40.5	6.95	36.0	5.57	31.5	4.39	
17	45.0	45.0	8.35	40.5	6.83	36.0	5.48	31.5	4.32	
15	45.0	45.0	8.22	40.5	6.73	36.0	5.40	31.5	4.27	

Outdoor Unit Dry-Bulb (°C)		Outdoor Unit 100 % Cooling Capacity (kW)	Compressor + Outdoor Fan Power consumption (kW)							
			60 %		50 %		40 %		30 %	
			TC (kW)	PI (kW)	TC (kW)	PI (kW)	TC (kW)	PI (kW)	TC (kW)	PI (kW)
40	41.9	25.1	5.74	20.9	4.34	16.8	3.40	12.6	2.97	
39	42.5	25.5	5.66	21.3	4.28	17.0	3.35	12.8	2.92	
37	43.8	26.3	5.48	21.9	4.15	17.5	3.24	13.1	2.83	
35	45.0	27.0	5.31	22.5	4.02	18.0	3.14	13.5	2.74	
33	45.0	27.0	4.94	22.5	3.76	18.0	2.98	13.5	2.64	
31	45.0	27.0	4.60	22.5	3.53	18.0	2.83	13.5	2.55	
30	45.0	27.0	4.45	22.5	3.43	18.0	2.76	13.5	2.50	
29	45.0	27.0	4.30	22.5	3.33	18.0	2.70	13.5	2.45	
27	45.0	27.0	4.03	22.5	3.14	18.0	2.57	13.5	2.36	
25	45.0	27.0	3.78	22.5	2.96	18.0	2.44	13.5	2.26	
23	45.0	27.0	3.55	22.5	2.79	18.0	2.32	13.5	2.17	
21	45.0	27.0	3.49	22.5	2.75	18.0	2.31	13.5	2.17	
20	45.0	27.0	3.46	22.5	2.74	18.0	2.30	13.5	2.17	
19	45.0	27.0	3.43	22.5	2.72	18.0	2.29	13.5	2.17	
17	45.0	27.0	3.39	22.5	2.70	18.0	2.28	13.5	2.17	
15	45.0	27.0	3.35	22.5	2.68	18.0	2.28	13.5	2.17	

TC : Total Capacity PI : Power Input
Indoor air temperature conditions : 27.0 °C dry-bulb / 19.0 °C wet bulb

Heating

Outdoor Unit Dry-Bulb (°C) Wet-Bulb (°C)			Outdoor Unit 100 % Heating Capacity (kW)	Compressor + Outdoor Fan Power consumption (kW)							
				100 %		90 %		80 %		70 %	
				TC (kW)	PI (kW)	TC (kW)	PI (kW)	TC (kW)	PI (kW)	TC (kW)	PI (kW)
15.0	13.7	50.0	50.0	11.9	45.0	9.74	40.0	7.92	35.0	6.40	
13.0	11.8	50.0	50.0	12.3	45.0	10.1	40.0	8.19	35.0	6.58	
11.0	9.8	50.0	50.0	12.9	45.0	10.5	40.0	8.51	35.0	6.81	
9.0	7.9	50.0	50.0	13.5	45.0	11.0	40.0	8.86	35.0	7.05	
7.0	6.0	50.0	50.0	14.2	45.0	11.5	40.0	9.26	35.0	7.33	
5.0	4.1	48.3	48.3	14.0	43.5	11.4	38.6	9.12	33.8	7.22	
3.0	2.2	46.6	46.6	13.8	41.9	11.2	37.3	8.98	32.6	7.11	
0.0	-0.7	43.9	43.9	13.4	39.5	10.9	35.1	8.76	30.7	6.94	
-3.0	-3.7	41.0	41.0	13.1	36.9	10.7	32.8	8.54	28.7	6.76	
-5.0	-5.6	39.1	39.1	12.9	35.2	10.5	31.3	8.40	27.4	6.65	
-7.0	-7.6	37.1	37.1	12.7	33.4	10.3	29.7	8.25	26.0	6.53	
-10	-10.5	34.1	34.1	12.3	30.7	10.0	27.3	8.04	23.9	6.36	
-14.5	-15.0	29.4	29.4	11.8	26.4	9.61	23.5	7.70	20.6	6.10	

Outdoor Unit Dry-Bulb (°C) Wet-Bulb (°C)			Outdoor Unit 100 % Heating Capacity (kW)	Compressor + Outdoor Fan Power consumption (kW)							
				60 %		50 %		40 %		30 %	
				TC (kW)	PI (kW)	TC (kW)	PI (kW)	TC (kW)	PI (kW)	TC (kW)	PI (kW)
15.0	13.7	50.0	30.0	5.18	25.0	4.25	20.0	3.63	15.0	3.30	
13.0	11.8	50.0	30.0	5.29	25.0	4.30	20.0	3.63	15.0	3.27	
11.0	9.8	50.0	30.0	5.43	25.0	4.37	20.0	3.64	15.0	3.24	
9.0	7.9	50.0	30.0	5.58	25.0	4.45	20.0	3.66	15.0	3.21	
7.0	6.0	48.3	30.0	5.76	25.0	4.54	20.0	3.69	15.0	3.19	
5.0	4.1	46.6	29.0	5.67	24.2	4.47	19.3	3.63	14.5	3.15	
3.0	2.2	43.9	27.9	5.58	23.3	4.41	18.6	3.58	14.0	3.10	
0.0	-0.7	41.0	26.3	5.45	21.9	4.30	17.5	3.49	13.2	3.02	
-3.0	-3.7	39.1	24.6	5.31	20.5	4.19	16.4	3.40	12.3	2.95	
-5.0	-5.6	37.1	23.5	5.22	19.6	4.12	15.6	3.35	11.7	2.90	
-7.0	-7.6	34.1	22.3	5.13	18.6	4.05	14.8	3.29	11.1	2.85	
-10	-10.5	29.4	20.5	5.00	17.1	3.94	13.7	3.20	10.2	2.77	
-14.5	-15.0	50.0	17.6	4.79	14.7	3.78	11.8	3.07	8.82	2.66	

TC : Total Capacity PI : Power Input
Indoor air temperature conditions : 20.0 °C dry-bulb



Combination

• Standard model

MMY-AP1814HT8P-E, AP1814T8P-E (18HP, 50.4 kW system)

Cooling

Outdoor Unit		Outdoor Unit 100 % Cooling Capacity (kW)	Compressor + Outdoor Fan				Power consumption (kW)			
Dry-Bulb (°C)	Heating Capacity (kW)		100 %		90 %		80 %		70 %	
			TC (kW)	PI (kW)	TC (kW)	PI (kW)	TC (kW)	PI (kW)	TC (kW)	PI (kW)
40	46.9	46.9	13.8	42.2	11.4	37.5	9.22	32.8	7.37	
39	47.7	47.7	13.6	42.9	11.2	38.1	9.08	33.4	7.26	
37	49.1	49.1	13.2	44.2	10.9	39.3	8.81	34.4	7.04	
35	50.4	50.4	12.8	45.4	10.5	40.3	8.53	35.3	6.82	
33	50.4	50.4	11.8	45.4	9.75	40.3	7.92	35.3	6.35	
31	50.4	50.4	11.0	45.4	9.06	40.3	7.37	35.3	5.93	
30	50.4	50.4	10.6	45.4	8.74	40.3	7.12	35.3	5.73	
29	50.4	50.4	10.2	45.4	8.44	40.3	6.88	35.3	5.55	
27	50.4	50.4	9.53	45.4	7.88	40.3	6.43	35.3	5.20	
25	50.4	50.4	8.89	45.4	7.36	40.3	6.02	35.3	4.88	
23	50.4	50.4	8.31	45.4	6.89	40.3	5.64	35.3	4.58	
21	50.4	50.4	8.14	45.4	6.75	40.3	5.54	35.3	4.50	
20	50.4	50.4	8.06	45.4	6.68	40.3	5.49	35.3	4.47	
19	50.4	50.4	7.98	45.4	6.63	40.3	5.44	35.3	4.43	
17	50.4	50.4	7.85	45.4	6.52	40.3	5.36	35.3	4.37	
15	50.4	50.4	7.74	45.4	6.43	40.3	5.30	35.3	4.33	

Outdoor Unit		Outdoor Unit 100 % Cooling Capacity (kW)	Compressor + Outdoor Fan				Power consumption (kW)			
Dry-Bulb (°C)	Heating Capacity (kW)		60 %		50 %		40 %		30 %	
			TC (kW)	PI (kW)	TC (kW)	PI (kW)	TC (kW)	PI (kW)	TC (kW)	PI (kW)
40	46.9	28.1	5.83	23.5	4.60	18.8	3.67	14.1	3.05	
39	47.7	28.6	5.74	23.8	4.53	19.1	3.61	14.3	3.00	
37	49.1	29.4	5.57	24.5	4.39	19.6	3.51	14.7	2.91	
35	50.4	30.2	5.39	25.2	4.25	20.2	3.39	15.1	2.82	
33	50.4	30.2	5.04	25.2	4.00	20.2	3.22	15.1	2.70	
31	50.4	30.2	4.73	25.2	3.77	20.2	3.06	15.1	2.58	
30	50.4	30.2	4.58	25.2	3.66	20.2	2.98	15.1	2.53	
29	50.4	30.2	4.44	25.2	3.56	20.2	2.90	15.1	2.47	
27	50.4	30.2	4.18	25.2	3.36	20.2	2.76	15.1	2.36	
25	50.4	30.2	3.93	25.2	3.18	20.2	2.62	15.1	2.25	
23	50.4	30.2	3.70	25.2	3.00	20.2	2.48	15.1	2.15	
21	50.4	30.2	3.65	25.2	2.97	20.2	2.46	15.1	2.14	
20	50.4	30.2	3.62	25.2	2.95	20.2	2.46	15.1	2.14	
19	50.4	30.2	3.60	25.2	2.94	20.2	2.45	15.1	2.13	
17	50.4	30.2	3.56	25.2	2.91	20.2	2.43	15.1	2.13	
15	50.4	30.2	3.52	25.2	2.89	20.2	2.42	15.1	2.12	

TC : Total Capacity PI : Power Input
Indoor air temperature conditions : 27.0 °C dry-bulb / 19.0 °C wet bulb

Heating

Outdoor Unit			Outdoor Unit 100 % Heating Capacity (kW)	Compressor + Outdoor Fan				Power consumption (kW)			
Dry-Bulb (°C)	Wet-Bulb (°C)	Heating Capacity (kW)		100 %		90 %		80 %		70 %	
				TC (kW)	PI (kW)	TC (kW)	PI (kW)	TC (kW)	PI (kW)	TC (kW)	PI (kW)
15.0	13.7	56.5	56.5	10.8	50.9	9.00	45.2	7.48	39.6	6.23	
13.0	11.8	56.5	56.5	11.3	50.9	9.30	45.2	7.69	39.6	6.37	
11.0	9.8	56.5	56.5	11.8	50.9	9.67	45.2	7.94	39.6	6.54	
9.0	7.9	56.5	56.5	12.4	50.9	10.1	45.2	8.23	39.6	6.72	
7.0	6.0	56.5	56.5	13.0	50.9	10.6	45.2	8.55	39.6	6.94	
5.0	4.1	54.6	54.6	12.8	49.1	10.4	43.7	8.42	38.2	6.83	
3.0	2.2	52.6	52.6	12.6	47.4	10.2	42.1	8.29	36.8	6.73	
0.0	-0.7	49.6	49.6	12.3	44.6	9.99	39.7	8.09	34.7	6.57	
-3.0	-3.7	46.3	46.3	12.0	41.7	9.74	37.0	7.89	32.4	6.40	
-5.0	-5.6	44.2	44.2	11.8	39.8	9.58	35.4	7.76	30.9	6.30	
-7.0	-7.6	41.9	41.9	11.6	37.7	9.41	33.6	7.62	29.4	6.19	
-10	-10.5	38.6	38.6	11.3	34.7	9.16	30.9	7.42	27.0	6.02	
-14.5	-15.0	33.2	33.2	10.8	29.9	8.78	26.6	7.11	23.2	5.77	

Outdoor Unit			Outdoor Unit 100 % Heating Capacity (kW)	Compressor + Outdoor Fan				Power consumption (kW)			
Dry-Bulb (°C)	Wet-Bulb (°C)	Heating Capacity (kW)		60 %		50 %		40 %		30 %	
				TC (kW)	PI (kW)	TC (kW)	PI (kW)	TC (kW)	PI (kW)	TC (kW)	PI (kW)
15.0	13.7	56.5	33.9	5.20	28.3	4.32	22.6	3.55	17.0	2.82	
13.0	11.8	56.5	33.9	5.29	28.3	4.37	22.6	3.58	17.0	2.84	
11.0	9.8	56.5	33.9	5.39	28.3	4.44	22.6	3.62	17.0	2.86	
9.0	7.9	56.5	33.9	5.51	28.3	4.51	22.6	3.66	17.0	2.89	
7.0	6.0	56.5	33.9	5.65	28.3	4.60	22.6	3.71	17.0	2.92	
5.0	4.1	54.6	32.7	5.56	27.3	4.53	21.8	3.66	16.4	2.88	
3.0	2.2	52.6	31.6	5.48	26.3	4.46	21.0	3.60	15.8	2.83	
0.0	-0.7	49.6	29.7	5.34	24.8	4.35	19.8	3.51	14.9	2.77	
-3.0	-3.7	46.3	27.8	5.21	23.2	4.24	18.5	3.43	13.9	2.70	
-5.0	-5.6	44.2	26.5	5.12	22.1	4.17	17.7	3.37	13.3	2.65	
-7.0	-7.6	41.9	25.2	5.03	21.0	4.10	16.8	3.31	12.6	2.60	
-10	-10.5	38.6	23.2	4.90	19.3	3.99	15.4	3.22	11.6	2.54	
-14.5	-15.0	33.2	19.9	4.70	16.6	3.82	13.3	3.09	9.96	2.43	

TC : Total Capacity PI : Power Input
Indoor air temperature conditions : 20.0 °C dry-bulb



MMY-AP2014HT8P-E, AP2014T8P-E (20HP, 56 kW system)

Cooling

Outdoor Unit Dry-Bulb (°C)		Outdoor Unit 100 % Cooling Capacity (kW)	Compressor + Outdoor Fan Power consumption (kW)							
			100 %		90 %		80 %		70 %	
			TC (kW)	PI (kW)	TC (kW)	PI (kW)	TC (kW)	PI (kW)	TC (kW)	PI (kW)
40	52.1	52.1	15.8	46.9	13.0	41.7	10.5	36.5	8.40	
39	52.9	52.9	15.8	47.7	13.0	42.4	10.5	37.1	8.40	
37	54.5	54.5	15.3	49.1	12.6	43.6	10.2	38.2	8.15	
35	56.0	56.0	14.8	50.4	12.2	44.8	9.87	39.2	7.89	
33	56.0	56.0	13.7	50.4	11.3	44.8	9.16	39.2	7.35	
31	56.0	56.0	12.7	50.4	10.5	44.8	8.53	39.2	6.86	
30	56.0	56.0	12.3	50.4	10.1	44.8	8.24	39.2	6.63	
29	56.0	56.0	11.8	50.4	9.76	44.8	7.96	39.2	6.42	
27	56.0	56.0	11.0	50.4	9.11	44.8	7.44	39.2	6.02	
25	56.0	56.0	10.3	50.4	8.52	44.8	6.97	39.2	5.65	
23	56.0	56.0	9.62	50.4	7.97	44.8	6.53	39.2	5.30	
21	56.0	56.0	9.41	50.4	7.80	44.8	6.40	39.2	5.21	
20	56.0	56.0	9.32	50.4	7.73	44.8	6.35	39.2	5.17	
19	56.0	56.0	9.24	50.4	7.67	44.8	6.30	39.2	5.13	
17	56.0	56.0	9.08	50.4	7.55	44.8	6.20	39.2	5.06	
15	56.0	56.0	8.96	50.4	7.44	44.8	6.13	39.2	5.00	

Outdoor Unit Dry-Bulb (°C)		Outdoor Unit 100 % Cooling Capacity (kW)	Compressor + Outdoor Fan Power consumption (kW)							
			60 %		50 %		40 %		30 %	
			TC (kW)	PI (kW)	TC (kW)	PI (kW)	TC (kW)	PI (kW)	TC (kW)	PI (kW)
40	52.1	31.3	6.64	26.1	5.24	20.8	4.18	15.6	3.48	
39	52.9	31.8	6.64	26.5	5.24	21.2	4.18	15.9	3.48	
37	54.5	32.7	6.44	27.3	5.08	21.8	4.06	16.4	3.37	
35	56.0	33.6	6.24	28.0	4.92	22.4	3.93	16.8	3.26	
33	56.0	33.6	5.84	28.0	4.63	22.4	3.72	16.8	3.12	
31	56.0	33.6	5.47	28.0	4.36	22.4	3.54	16.8	2.99	
30	56.0	33.6	5.30	28.0	4.24	22.4	3.45	16.8	2.92	
29	56.0	33.6	5.14	28.0	4.12	22.4	3.36	16.8	2.86	
27	56.0	33.6	4.83	28.0	3.89	22.4	3.19	16.8	2.73	
25	56.0	33.6	4.55	28.0	3.68	22.4	3.03	16.8	2.61	
23	56.0	33.6	4.28	28.0	3.47	22.4	2.87	16.8	2.49	
21	56.0	33.6	4.22	28.0	3.43	22.4	2.85	16.8	2.48	
20	56.0	33.6	4.19	28.0	3.41	22.4	2.84	16.8	2.47	
19	56.0	33.6	4.16	28.0	3.40	22.4	2.83	16.8	2.47	
17	56.0	33.6	4.12	28.0	3.37	22.4	2.82	16.8	2.46	
15	56.0	33.6	4.08	28.0	3.34	22.4	2.80	16.8	2.46	

TC : Total Capacity PI : Power Input
Indoor air temperature conditions : 27.0 °C dry-bulb / 19.0 °C wet bulb

Heating

Outdoor Unit Dry-Bulb (°C) Wet-Bulb (°C) Heating Capacity (kW)			Compressor + Outdoor Fan Power consumption (kW)							
			100 %		90 %		80 %		70 %	
			TC (kW)	PI (kW)	TC (kW)	PI (kW)	TC (kW)	PI (kW)	TC (kW)	PI (kW)
15.0	13.7	63.0	63.0	12.5	56.7	10.4	50.4	8.62	44.1	7.18
13.0	11.8	63.0	63.0	13.0	56.7	10.7	50.4	8.85	44.1	7.34
11.0	9.8	63.0	63.0	13.6	56.7	11.1	50.4	9.15	44.1	7.53
9.0	7.9	63.0	63.0	14.2	56.7	11.6	50.4	9.47	44.1	7.74
7.0	6.0	63.0	63.0	15.0	56.7	12.2	50.4	9.84	44.1	7.99
5.0	4.1	60.9	60.9	14.8	54.8	12.0	48.7	9.69	42.6	7.87
3.0	2.2	58.7	58.7	14.5	52.8	11.8	46.9	9.54	41.1	7.75
0.0	-0.7	55.3	55.3	14.2	49.7	11.5	44.2	9.32	38.7	7.56
-3.0	-3.7	51.6	51.6	13.8	46.5	11.2	41.3	9.08	36.1	7.37
-5.0	-5.6	49.3	49.3	13.6	44.4	11.0	39.4	8.93	34.5	7.25
-7.0	-7.6	46.8	46.8	13.4	42.1	10.8	37.4	8.77	32.7	7.12
-10	-10.5	43.0	43.0	13.0	38.7	10.5	34.4	8.54	30.1	6.93
-14.5	-15.0	37.0	37.0	12.5	33.3	10.1	29.6	8.19	25.9	6.65

Outdoor Unit Dry-Bulb (°C) Wet-Bulb (°C) Heating Capacity (kW)			Compressor + Outdoor Fan Power consumption (kW)							
			60 %		50 %		40 %		30 %	
			TC (kW)	PI (kW)	TC (kW)	PI (kW)	TC (kW)	PI (kW)	TC (kW)	PI (kW)
15.0	13.7	63.0	37.8	5.98	31.5	4.97	25.2	4.08	18.9	3.25
13.0	11.8	63.0	37.8	6.09	31.5	5.04	25.2	4.12	18.9	3.27
11.0	9.8	63.0	37.8	6.21	31.5	5.11	25.2	4.17	18.9	3.30
9.0	7.9	63.0	37.8	6.34	31.5	5.20	25.2	4.22	18.9	3.33
7.0	6.0	63.0	37.8	6.50	31.5	5.29	25.2	4.28	18.9	3.36
5.0	4.1	60.9	36.5	6.40	30.4	5.21	24.3	4.21	18.3	3.31
3.0	2.2	58.7	35.2	6.30	29.3	5.13	23.5	4.14	17.6	3.26
0.0	-0.7	55.3	33.2	6.15	27.6	5.01	22.1	4.05	16.6	3.18
-3.0	-3.7	51.6	31.0	6.00	25.8	4.88	20.7	3.94	15.5	3.10
-5.0	-5.6	49.3	29.6	5.90	24.6	4.80	19.7	3.88	14.8	3.05
-7.0	-7.6	46.8	28.1	5.79	23.4	4.72	18.7	3.81	14.0	3.00
-10	-10.5	43.0	25.8	5.64	21.5	4.59	17.2	3.71	12.9	2.92
-14.5	-15.0	37.0	22.2	5.41	18.5	4.40	14.8	3.56	11.1	2.80

TC : Total Capacity PI : Power Input
Indoor air temperature conditions : 20.0 °C dry-bulb



MMY-AP2214HT8P-E, AP2214T8P-E (22HP, 61.5 kW system)

Cooling

Outdoor Unit Dry-Bulb (°C)		Outdoor Unit 100 % Cooling Capacity (kW)	Compressor + Outdoor Fan Power consumption (kW)							
			100 %		90 %		80 %		70 %	
			TC (kW)	PI (kW)	TC (kW)	PI (kW)	TC (kW)	PI (kW)	TC (kW)	PI (kW)
40	57.2	57.2	18.3	51.5	15.0	45.8	12.1	40.1	9.64	
39	58.2	58.2	18.0	52.3	14.8	46.5	11.9	40.7	9.49	
37	59.9	59.9	17.5	53.9	14.3	47.9	11.6	41.9	9.21	
35	61.5	61.5	17.0	55.4	13.9	49.2	11.2	43.1	8.92	
33	61.5	61.5	15.7	55.4	12.8	49.2	10.4	43.1	8.30	
31	61.5	61.5	14.5	55.4	11.9	49.2	9.66	43.1	7.74	
30	61.5	61.5	14.0	55.4	11.5	49.2	9.33	43.1	7.49	
29	61.5	61.5	13.5	55.4	11.1	49.2	9.01	43.1	7.24	
27	61.5	61.5	12.6	55.4	10.4	49.2	8.42	43.1	6.79	
25	61.5	61.5	11.7	55.4	9.67	49.2	7.88	43.1	6.37	
23	61.5	61.5	11.0	55.4	9.04	49.2	7.38	43.1	5.97	
21	61.5	61.5	10.7	55.4	8.86	49.2	7.24	43.1	5.87	
20	61.5	61.5	10.6	55.4	8.77	49.2	7.18	43.1	5.82	
19	61.5	61.5	10.5	55.4	8.69	49.2	7.12	43.1	5.78	
17	61.5	61.5	10.3	55.4	8.56	49.2	7.01	43.1	5.70	
15	61.5	61.5	10.2	55.4	8.44	49.2	6.92	43.1	5.64	

Outdoor Unit Dry-Bulb (°C)		Outdoor Unit 100 % Cooling Capacity (kW)	Compressor + Outdoor Fan Power consumption (kW)							
			60 %		50 %		40 %		30 %	
			TC (kW)	PI (kW)	TC (kW)	PI (kW)	TC (kW)	PI (kW)	TC (kW)	PI (kW)
40	57.2	34.3	7.60	28.6	5.97	22.9	4.77	17.2	3.97	
39	58.2	34.9	7.48	29.1	5.88	23.3	4.70	17.4	3.91	
37	59.9	35.9	7.26	29.9	5.71	24.0	4.55	18.0	3.79	
35	61.5	36.9	7.03	30.8	5.53	24.6	4.41	18.5	3.67	
33	61.5	36.9	6.57	30.8	5.20	24.6	4.18	18.5	3.51	
31	61.5	36.9	6.16	30.8	4.90	24.6	3.97	18.5	3.36	
30	61.5	36.9	5.96	30.8	4.76	24.6	3.87	18.5	3.29	
29	61.5	36.9	5.78	30.8	4.62	24.6	3.77	18.5	3.22	
27	61.5	36.9	5.44	30.8	4.37	24.6	3.58	18.5	3.08	
25	61.5	36.9	5.11	30.8	4.13	24.6	3.40	18.5	2.94	
23	61.5	36.9	4.81	30.8	3.90	24.6	3.23	18.5	2.80	
21	61.5	36.9	4.74	30.8	3.85	24.6	3.20	18.5	2.79	
20	61.5	36.9	4.71	30.8	3.83	24.6	3.19	18.5	2.78	
19	61.5	36.9	4.68	30.8	3.81	24.6	3.18	18.5	2.78	
17	61.5	36.9	4.63	30.8	3.78	24.6	3.16	18.5	2.77	
15	61.5	36.9	4.58	30.8	3.75	24.6	3.15	18.5	2.77	

TC : Total Capacity PI : Power Input
Indoor air temperature conditions : 27.0 °C dry-bulb / 19.0 °C wet bulb

Heating

Outdoor Unit Dry-Bulb (°C) Wet-Bulb (°C)			Outdoor Unit 100 % Heating Capacity (kW)	Compressor + Outdoor Fan Power consumption (kW)							
				100 %		90 %		80 %		70 %	
				TC (kW)	PI (kW)	TC (kW)	PI (kW)	TC (kW)	PI (kW)	TC (kW)	PI (kW)
15.0	13.7	69.0	69.0	14.7	62.1	12.2	55.2	10.1	48.3	8.38	
13.0	11.8	69.0	69.0	15.3	62.1	12.6	55.2	10.4	48.3	8.57	
11.0	9.8	69.0	69.0	16.0	62.1	13.2	55.2	10.8	48.3	8.81	
9.0	7.9	69.0	69.0	16.8	62.1	13.7	55.2	11.2	48.3	9.08	
7.0	6.0	69.0	69.0	17.7	62.1	14.4	55.2	11.6	48.3	9.38	
5.0	4.1	66.7	66.7	17.4	60.0	14.1	53.3	11.4	46.7	9.24	
3.0	2.2	64.3	64.3	17.2	57.8	13.9	51.4	11.3	45.0	9.10	
0.0	-0.7	60.5	60.5	16.7	54.5	13.6	48.4	11.0	42.4	8.88	
-3.0	-3.7	56.6	56.6	16.3	50.9	13.2	45.2	10.7	39.6	8.65	
-5.0	-5.6	54.0	54.0	16.1	48.6	13.0	43.2	10.5	37.8	8.51	
-7.0	-7.6	51.2	51.2	15.8	46.1	12.8	41.0	10.3	35.9	8.36	
-10	-10.5	47.1	47.1	15.4	42.4	12.5	37.7	10.1	33.0	8.14	
-14.5	-15.0	40.6	40.6	14.7	36.5	11.9	32.4	9.66	28.4	7.80	

Outdoor Unit Dry-Bulb (°C) Wet-Bulb (°C)			Outdoor Unit 100 % Heating Capacity (kW)	Compressor + Outdoor Fan Power consumption (kW)							
				60 %		50 %		40 %		30 %	
				TC (kW)	PI (kW)	TC (kW)	PI (kW)	TC (kW)	PI (kW)	TC (kW)	PI (kW)
15.0	13.7	69.0	41.4	6.94	34.5	5.76	27.6	4.75	20.7	3.88	
13.0	11.8	69.0	41.4	7.07	34.5	5.83	27.6	4.79	20.7	3.90	
11.0	9.8	69.0	41.4	7.22	34.5	5.92	27.6	4.84	20.7	3.91	
9.0	7.9	69.0	41.4	7.39	34.5	6.02	27.6	4.89	20.7	3.94	
7.0	6.0	69.0	41.4	7.58	34.5	6.13	27.6	4.95	20.7	3.97	
5.0	4.1	66.7	40.0	7.46	33.3	6.04	26.7	4.88	20.0	3.91	
3.0	2.2	64.3	38.6	7.35	32.1	5.94	25.7	4.80	19.3	3.85	
0.0	-0.7	60.5	36.3	7.17	30.3	5.80	24.2	4.69	18.2	3.75	
-3.0	-3.7	56.6	33.9	6.99	28.3	5.65	22.6	4.57	17.0	3.66	
-5.0	-5.6	54.0	32.4	6.88	27.0	5.56	21.6	4.49	16.2	3.60	
-7.0	-7.6	51.2	30.7	6.75	25.6	5.46	20.5	4.41	15.4	3.54	
-10	-10.5	47.1	28.3	6.58	23.6	5.32	18.8	4.30	14.1	3.44	
-14.5	-15.0	40.6	24.3	6.31	20.3	5.10	16.2	4.12	12.2	3.30	

TC : Total Capacity PI : Power Input
Indoor air temperature conditions : 20.0 °C dry-bulb



MMY-AP2414HT8P-E, AP2414T8P-E (24HP, 68 kW system)

Cooling

Outdoor Unit Dry-Bulb (°C)		Outdoor Unit 100 % Cooling Capacity (kW)	Compressor + Outdoor Fan Power consumption (kW)							
			100 %		90 %		80 %		70 %	
			TC (kW)	PI (kW)	TC (kW)	PI (kW)	TC (kW)	PI (kW)	TC (kW)	PI (kW)
40	63.3	63.3	21.2	57.0	17.3	50.6	13.9	44.3	11.0	
39	64.3	64.3	20.9	57.9	17.0	51.4	13.7	45.0	10.9	
37	66.2	66.2	20.3	59.6	16.5	53.0	13.3	46.4	10.5	
35	68.0	68.0	19.7	61.2	16.0	54.4	12.9	47.6	10.2	
33	68.0	68.0	18.1	61.2	14.8	54.4	11.9	47.6	9.49	
31	68.0	68.0	16.8	61.2	13.7	54.4	11.1	47.6	8.85	
30	68.0	68.0	16.2	61.2	13.2	54.4	10.7	47.6	8.56	
29	68.0	68.0	15.6	61.2	12.8	54.4	10.3	47.6	8.28	
27	68.0	68.0	14.5	61.2	11.9	54.4	9.66	47.6	7.75	
25	68.0	68.0	13.5	61.2	11.1	54.4	9.03	47.6	7.27	
23	68.0	68.0	12.6	61.2	10.4	54.4	8.46	47.6	6.82	
21	68.0	68.0	12.4	61.2	10.2	54.4	8.29	47.6	6.70	
20	68.0	68.0	12.2	61.2	10.1	54.4	8.22	47.6	6.64	
19	68.0	68.0	12.1	61.2	9.99	54.4	8.15	47.6	6.59	
17	68.0	68.0	11.9	61.2	9.83	54.4	8.02	47.6	6.50	
15	68.0	68.0	11.7	61.2	9.69	54.4	7.92	47.6	6.43	

Outdoor Unit Dry-Bulb (°C)		Outdoor Unit 100 % Cooling Capacity (kW)	Compressor + Outdoor Fan Power consumption (kW)							
			60 %		50 %		40 %		30 %	
			TC (kW)	PI (kW)	TC (kW)	PI (kW)	TC (kW)	PI (kW)	TC (kW)	PI (kW)
40	64.3	38.0	8.66	31.6	6.80	25.3	5.42	19.0	4.52	
39	66.2	38.6	8.53	32.1	6.69	25.7	5.34	19.3	4.45	
37	68.0	39.7	8.28	33.1	6.49	26.5	5.18	19.9	4.32	
35	68.0	40.8	8.02	34.0	6.29	27.2	5.01	20.4	4.18	
33	68.0	40.8	7.49	34.0	5.91	27.2	4.75	20.4	4.00	
31	68.0	40.8	7.02	34.0	5.57	27.2	4.51	20.4	3.83	
30	68.0	40.8	6.80	34.0	5.41	27.2	4.40	20.4	3.75	
29	68.0	40.8	6.59	34.0	5.26	27.2	4.29	20.4	3.67	
27	68.0	40.8	6.19	34.0	4.97	27.2	4.07	20.4	3.51	
25	68.0	40.8	5.82	34.0	4.69	27.2	3.87	20.4	3.35	
23	68.0	40.8	5.48	34.0	4.43	27.2	3.67	20.4	3.19	
21	68.0	40.8	5.40	34.0	4.38	27.2	3.64	20.4	3.18	
20	68.0	40.8	5.36	34.0	4.36	27.2	3.63	20.4	3.18	
19	68.0	40.8	5.33	34.0	4.34	27.2	3.62	20.4	3.17	
17	68.0	40.8	5.26	34.0	4.30	27.2	3.60	20.4	3.16	
15	63.3	40.8	5.21	34.0	4.26	27.2	3.58	20.4	3.16	

TC : Total Capacity PI : Power Input
Indoor air temperature conditions : 27.0 °C dry-bulb / 19.0 °C wet bulb

Heating

Outdoor Unit Dry-Bulb (°C) Wet-Bulb (°C)			Outdoor Unit 100 % Heating Capacity (kW)	Compressor + Outdoor Fan Power consumption (kW)							
				100 %		90 %		80 %		70 %	
				TC (kW)	PI (kW)	TC (kW)	PI (kW)	TC (kW)	PI (kW)	TC (kW)	PI (kW)
15.0	13.7	76.5	76.5	17.6	68.9	14.6	61.2	12.0	53.6	9.90	
13.0	11.8	76.5	76.5	18.3	68.9	15.1	61.2	12.4	53.6	10.1	
11.0	9.8	76.5	76.5	19.2	68.9	15.7	61.2	12.8	53.6	10.4	
9.0	7.9	76.5	76.5	20.1	68.9	16.4	61.2	13.3	53.6	10.8	
7.0	6.0	76.5	76.5	21.1	68.9	17.2	61.2	13.9	53.6	11.1	
5.0	4.1	73.9	73.9	20.8	66.5	16.9	59.1	13.6	51.7	11.0	
3.0	2.2	71.3	71.3	20.5	64.1	16.6	57.0	13.4	49.9	10.8	
0.0	-0.7	67.1	67.1	20.0	60.4	16.2	53.7	13.1	47.0	10.5	
-3.0	-3.7	62.7	62.7	19.5	56.4	15.8	50.2	12.8	43.9	10.3	
-5.0	-5.6	59.8	59.8	19.2	53.9	15.6	47.9	12.6	41.9	10.1	
-7.0	-7.6	56.8	56.8	18.8	51.1	15.3	45.4	12.4	39.8	9.93	
-10	-10.5	52.2	52.2	18.3	47.0	14.9	41.8	12.0	36.6	9.67	
-14.5	-15.0	45.0	45.0	17.6	40.5	14.3	36.0	11.53	31.5	9.27	

Outdoor Unit Dry-Bulb (°C) Wet-Bulb (°C)			Outdoor Unit 100 % Heating Capacity (kW)	Compressor + Outdoor Fan Power consumption (kW)							
				60 %		50 %		40 %		30 %	
				TC (kW)	PI (kW)	TC (kW)	PI (kW)	TC (kW)	PI (kW)	TC (kW)	PI (kW)
15.0	13.7	76.5	45.9	8.15	38.3	6.74	30.6	5.60	23.0	4.69	
13.0	11.8	76.5	45.9	8.30	38.3	6.82	30.6	5.64	23.0	4.69	
11.0	9.8	76.5	45.9	8.49	38.3	6.93	30.6	5.68	23.0	4.70	
9.0	7.9	76.5	45.9	8.70	38.3	7.04	30.6	5.74	23.0	4.71	
7.0	6.0	76.5	45.9	8.94	38.3	7.18	30.6	5.81	23.0	4.73	
5.0	4.1	73.9	44.3	8.80	37.0	7.07	29.6	5.72	22.2	4.66	
3.0	2.2	71.3	42.8	8.67	35.6	6.97	28.5	5.63	21.4	4.59	
0.0	-0.7	67.1	40.3	8.46	33.6	6.80	26.8	5.49	20.1	4.48	
-3.0	-3.7	62.7	37.6	8.25	31.4	6.63	25.1	5.35	18.8	4.37	
-5.0	-5.6	59.8	35.9	8.11	29.9	6.52	23.9	5.27	18.0	4.29	
-7.0	-7.6	56.8	34.1	7.97	28.4	6.40	22.7	5.17	17.0	4.22	
-10	-10.5	52.2	31.3	7.76	26.1	6.24	20.9	5.04	15.7	4.11	
-14.5	-15.0	45.0	27.0	7.44	22.5	5.98	18.0	4.83	13.5	3.94	

TC : Total Capacity PI : Power Input
Indoor air temperature conditions : 20.0 °C dry-bulb



MMY-AP2614HT8P-E, AP2614T8P-E (26HP, 73 kW system)

Cooling

Outdoor Unit Dry-Bulb (°C)		Outdoor Unit 100 % Cooling Capacity (kW)	Compressor + Outdoor Fan Power consumption (kW)							
			100 %		90 %		80 %		70 %	
			TC (kW)	PI (kW)	TC (kW)	PI (kW)	TC (kW)	PI (kW)	TC (kW)	PI (kW)
40	67.9	67.9	22.8	61.1	18.7	54.3	15.1	47.6	11.9	
39	69.0	69.0	22.5	62.1	18.4	55.2	14.8	48.3	11.7	
37	71.1	71.1	21.8	64.0	17.9	56.9	14.4	49.8	11.4	
35	73.0	73.0	21.1	65.7	17.3	58.4	13.9	51.1	11.0	
33	73.0	73.0	19.5	65.7	16.0	58.4	12.9	51.1	10.2	
31	73.0	73.0	18.1	65.7	14.9	58.4	12.0	51.1	9.51	
30	73.0	73.0	17.5	65.7	14.3	58.4	11.6	51.1	9.19	
29	73.0	73.0	16.8	65.7	13.8	58.4	11.2	51.1	8.88	
27	73.0	73.0	15.7	65.7	12.9	58.4	10.4	51.1	8.31	
25	73.0	73.0	14.6	65.7	12.0	58.4	9.75	51.1	7.78	
23	73.0	73.0	13.7	65.7	11.3	58.4	9.12	51.1	7.29	
21	73.0	73.0	13.4	65.7	11.0	58.4	8.94	51.1	7.15	
20	73.0	73.0	13.2	65.7	10.9	58.4	8.86	51.1	7.09	
19	73.0	73.0	13.1	65.7	10.8	58.4	8.78	51.1	7.04	
17	73.0	73.0	12.9	65.7	10.6	58.4	8.64	51.1	6.94	
15	73.0	73.0	12.7	65.7	10.5	58.4	8.52	51.1	6.85	

Outdoor Unit Dry-Bulb (°C)		Outdoor Unit 100 % Cooling Capacity (kW)	Compressor + Outdoor Fan Power consumption (kW)							
			60 %		50 %		40 %		30 %	
			TC (kW)	PI (kW)	TC (kW)	PI (kW)	TC (kW)	PI (kW)	TC (kW)	PI (kW)
40	67.9	40.8	9.23	34.0	7.13	27.2	5.64	20.4	4.80	
39	69.0	41.4	9.09	34.5	7.02	27.6	5.56	20.7	4.73	
37	71.1	42.7	8.81	35.5	6.81	28.4	5.39	21.3	4.58	
35	73.0	43.8	8.54	36.5	6.60	29.2	5.22	21.9	4.44	
33	73.0	43.8	7.96	36.5	6.19	29.2	4.95	21.9	4.26	
31	73.0	43.8	7.44	36.5	5.83	29.2	4.70	21.9	4.09	
30	73.0	43.8	7.20	36.5	5.66	29.2	4.58	21.9	4.01	
29	73.0	43.8	6.98	36.5	5.50	29.2	4.47	21.9	3.93	
27	73.0	43.8	6.55	36.5	5.19	29.2	4.25	21.9	3.76	
25	73.0	43.8	6.15	36.5	4.90	29.2	4.04	21.9	3.60	
23	73.0	43.8	5.78	36.5	4.62	29.2	3.84	21.9	3.44	
21	73.0	43.8	5.69	36.5	4.57	29.2	3.81	21.9	3.44	
20	73.0	43.8	5.65	36.5	4.54	29.2	3.80	21.9	3.43	
19	73.0	43.8	5.61	36.5	4.52	29.2	3.78	21.9	3.43	
17	73.0	43.8	5.54	36.5	4.48	29.2	3.76	21.9	3.43	
15	73.0	43.8	5.48	36.5	4.44	29.2	3.75	21.9	3.42	

TC : Total Capacity PI : Power Input
Indoor air temperature conditions : 27.0 °C dry-bulb / 19.0 °C wet bulb

Heating

Outdoor Unit Dry-Bulb (°C) Wet-Bulb (°C)			Outdoor Unit 100 % Heating Capacity (kW)	Compressor + Outdoor Fan Power consumption (kW)							
				100 %		90 %		80 %		70 %	
				TC (kW)	PI (kW)	TC (kW)	PI (kW)	TC (kW)	PI (kW)	TC (kW)	PI (kW)
15.0	13.7	81.5	81.5	18.1	73.4	14.9	65.2	12.3	57.1	10.1	
13.0	11.8	81.5	81.5	18.8	73.4	15.5	65.2	12.7	57.1	10.3	
11.0	9.8	81.5	81.5	19.7	73.4	16.1	65.2	13.1	57.1	10.6	
9.0	7.9	81.5	81.5	20.6	73.4	16.8	65.2	13.6	57.1	11.0	
7.0	6.0	81.5	81.5	21.7	73.4	17.6	65.2	14.2	57.1	11.4	
5.0	4.1	78.7	78.7	21.4	70.9	17.3	63.0	14.0	55.1	11.2	
3.0	2.2	75.9	75.9	21.0	68.3	17.1	60.7	13.8	53.1	11.0	
0.0	-0.7	71.5	71.5	20.5	64.3	16.7	57.2	13.4	50.0	10.8	
-3.0	-3.7	66.8	66.8	20.0	60.1	16.2	53.4	13.1	46.8	10.5	
-5.0	-5.6	63.8	63.8	19.7	57.4	16.0	51.0	12.9	44.6	10.3	
-7.0	-7.6	60.5	60.5	19.3	54.4	15.7	48.4	12.7	42.3	10.1	
-10	-10.5	55.7	55.7	18.8	50.1	15.3	44.5	12.3	39.0	9.88	
-14.5	-15.0	47.9	47.9	18.1	43.1	14.7	38.3	11.8	33.5	9.47	

Outdoor Unit Dry-Bulb (°C) Wet-Bulb (°C)			Outdoor Unit 100 % Heating Capacity (kW)	Compressor + Outdoor Fan Power consumption (kW)							
				60 %		50 %		40 %		30 %	
				TC (kW)	PI (kW)	TC (kW)	PI (kW)	TC (kW)	PI (kW)	TC (kW)	PI (kW)
15.0	13.7	81.5	48.9	8.29	40.8	6.85	32.6	5.72	24.5	4.87	
13.0	11.8	81.5	48.9	8.44	40.8	6.93	32.6	5.75	24.5	4.86	
11.0	9.8	81.5	48.9	8.64	40.8	7.04	32.6	5.80	24.5	4.86	
9.0	7.9	81.5	48.9	8.85	40.8	7.16	32.6	5.85	24.5	4.86	
7.0	6.0	81.5	48.9	9.10	40.8	7.30	32.6	5.91	24.5	4.88	
5.0	4.1	78.7	47.2	8.96	39.4	7.19	31.5	5.82	23.6	4.80	
3.0	2.2	75.9	45.5	8.82	38.0	7.08	30.4	5.73	22.8	4.73	
0.0	-0.7	71.5	42.9	8.61	35.7	6.91	28.6	5.59	21.4	4.61	
-3.0	-3.7	66.8	40.1	8.39	33.4	6.73	26.7	5.45	20.0	4.50	
-5.0	-5.6	63.8	38.3	8.26	31.9	6.62	25.5	5.36	19.1	4.42	
-7.0	-7.6	60.5	36.3	8.11	30.2	6.51	24.2	5.27	18.1	4.34	
-10	-10.5	55.7	33.4	7.90	27.8	6.34	22.3	5.13	16.7	4.23	
-14.5	-15.0	47.9	28.7	7.57	24.0	6.07	19.2	4.92	14.4	4.06	

TC : Total Capacity PI : Power Input
Indoor air temperature conditions : 20.0 °C dry-bulb



MMY-AP2814HT8P-E, AP2814T8P-E (28HP, 78.5 kW system)

Cooling

Outdoor Unit Dry-Bulb (°C)		Outdoor Unit 100 % Cooling Capacity (kW)	Compressor + Outdoor Fan Power consumption (kW)							
			100 %		90 %		80 %		70 %	
			TC (kW)	PI (kW)	TC (kW)	PI (kW)	TC (kW)	PI (kW)	TC (kW)	PI (kW)
40	73.1	73.1	25.1	65.7	20.5	58.4	16.4	51.1	12.9	
39	74.2	74.2	24.7	66.8	20.2	59.4	16.2	52.0	12.7	
37	76.4	76.4	24.0	68.8	19.6	61.2	15.7	53.5	12.3	
35	78.5	78.5	23.3	70.7	19.0	62.8	15.2	55.0	12.0	
33	78.5	78.5	21.5	70.7	17.6	62.8	14.1	55.0	11.1	
31	78.5	78.5	19.9	70.7	16.3	62.8	13.1	55.0	10.33	
30	78.5	78.5	19.2	70.7	15.7	62.8	12.6	55.0	9.98	
29	78.5	78.5	18.5	70.7	15.1	62.8	12.2	55.0	9.64	
27	78.5	78.5	17.2	70.7	14.1	62.8	11.4	55.0	9.01	
25	78.5	78.5	16.1	70.7	13.2	62.8	10.6	55.0	8.44	
23	78.5	78.5	15.0	70.7	12.3	62.8	9.93	55.0	7.91	
21	78.5	78.5	14.7	70.7	12.0	62.8	9.72	55.0	7.75	
20	78.5	78.5	14.5	70.7	11.9	62.8	9.63	55.0	7.69	
19	78.5	78.5	14.4	70.7	11.8	62.8	9.55	55.0	7.63	
17	78.5	78.5	14.1	70.7	11.6	62.8	9.40	55.0	7.52	
15	78.5	78.5	13.9	70.7	11.4	62.8	9.27	55.0	7.42	

Outdoor Unit Dry-Bulb (°C)		Outdoor Unit 100 % Cooling Capacity (kW)	Compressor + Outdoor Fan Power consumption (kW)							
			60 %		50 %		40 %		30 %	
			TC (kW)	PI (kW)	TC (kW)	PI (kW)	TC (kW)	PI (kW)	TC (kW)	PI (kW)
40	73.1	43.8	9.99	36.5	7.70	29.2	6.08	21.9	5.19	
39	74.2	44.5	9.85	37.1	7.59	29.7	5.99	22.3	5.11	
37	76.4	45.9	9.55	38.2	7.36	30.6	5.81	22.9	4.96	
35	78.5	47.1	9.25	39.3	7.13	31.4	5.63	23.6	4.80	
33	78.5	47.1	8.62	39.3	6.69	31.4	5.34	23.6	4.61	
31	78.5	47.1	8.06	39.3	6.29	31.4	5.07	23.6	4.43	
30	78.5	47.1	7.80	39.3	6.11	31.4	4.95	23.6	4.34	
29	78.5	47.1	7.55	39.3	5.93	31.4	4.82	23.6	4.25	
27	78.5	47.1	7.08	39.3	5.60	31.4	4.59	23.6	4.07	
25	78.5	47.1	6.65	39.3	5.28	31.4	4.36	23.6	3.90	
23	78.5	47.1	6.25	39.3	4.99	31.4	4.14	23.6	3.73	
21	78.5	47.1	6.15	39.3	4.93	31.4	4.11	23.6	3.72	
20	78.5	47.1	6.10	39.3	4.90	31.4	4.10	23.6	3.72	
19	78.5	47.1	6.06	39.3	4.87	31.4	4.09	23.6	3.72	
17	78.5	47.1	5.99	39.3	4.83	31.4	4.07	23.6	3.71	
15	78.5	47.1	5.92	39.3	4.79	31.4	4.05	23.6	3.71	

TC : Total Capacity PI : Power Input
Indoor air temperature conditions : 27.0 °C dry-bulb / 19.0 °C wet bulb

Heating

Outdoor Unit Dry-Bulb (°C) Wet-Bulb (°C) Heating Capacity (kW)			Compressor + Outdoor Fan Power consumption (kW)							
			100 %		90 %		80 %		70 %	
			TC (kW)	PI (kW)	TC (kW)	PI (kW)	TC (kW)	PI (kW)	TC (kW)	PI (kW)
15.0	13.7	88.0	88.0	20.6	79.2	17.0	70.4	13.9	61.6	11.3
13.0	11.8	88.0	88.0	21.4	79.2	17.6	70.4	14.3	61.6	11.6
11.0	9.8	88.0	88.0	22.4	79.2	18.3	70.4	14.9	61.6	12.0
9.0	7.9	88.0	88.0	23.4	79.2	19.1	70.4	15.5	61.6	12.4
7.0	6.0	88.0	88.0	24.7	79.2	20.0	70.4	16.1	61.6	12.9
5.0	4.1	85.0	85.0	24.3	76.5	19.7	68.0	15.9	59.5	12.7
3.0	2.2	82.0	82.0	23.9	73.8	19.4	65.6	15.6	57.4	12.5
0.0	-0.7	77.2	77.2	23.3	69.5	19.0	61.8	15.3	54.0	12.2
-3.0	-3.7	72.1	72.1	22.7	64.9	18.5	57.7	14.9	50.5	11.9
-5.0	-5.6	68.8	68.8	22.4	62.0	18.2	55.1	14.6	48.2	11.7
-7.0	-7.6	65.3	65.3	22.0	58.8	17.9	52.3	14.4	45.7	11.5
-10	-10.5	60.1	60.1	21.4	54.1	17.4	48.1	14.0	42.1	11.16
-14.5	-15.0	51.7	51.7	20.5	46.6	16.7	41.4	13.4	36.2	10.70

Outdoor Unit Dry-Bulb (°C) Wet-Bulb (°C) Heating Capacity (kW)			Compressor + Outdoor Fan Power consumption (kW)							
			60 %		50 %		40 %		30 %	
			TC (kW)	PI (kW)	TC (kW)	PI (kW)	TC (kW)	PI (kW)	TC (kW)	PI (kW)
15.0	13.7	88.0	52.8	9.25	44.0	7.62	35.2	6.41	26.4	5.60
13.0	11.8	88.0	52.8	9.43	44.0	7.71	35.2	6.44	26.4	5.57
11.0	9.8	88.0	52.8	9.66	44.0	7.83	35.2	6.47	26.4	5.55
9.0	7.9	88.0	52.8	9.91	44.0	7.97	35.2	6.52	26.4	5.54
7.0	6.0	88.0	52.8	10.2	44.0	8.13	35.2	6.59	26.4	5.53
5.0	4.1	85.0	51.0	10.1	42.5	8.01	34.0	6.49	25.5	5.45
3.0	2.2	82.0	49.2	9.90	41.0	7.89	32.8	6.39	24.6	5.37
0.0	-0.7	77.2	46.3	9.66	38.6	7.70	30.9	6.24	23.2	5.24
-3.0	-3.7	72.1	43.3	9.42	36.1	7.50	28.9	6.08	21.6	5.10
-5.0	-5.6	68.8	41.3	9.26	34.4	7.38	27.5	5.98	20.7	5.02
-7.0	-7.6	65.3	39.2	9.10	32.7	7.25	26.1	5.87	19.6	4.93
-10	-10.5	60.1	36.1	8.86	30.0	7.06	24.0	5.72	18.0	4.80
-14.5	-15.0	51.7	31.0	8.50	25.9	6.77	20.7	5.48	15.5	4.60

TC : Total Capacity PI : Power Input
Indoor air temperature conditions : 20.0 °C dry-bulb



MMY-AP3014HT8P-E, AP3014T8P-E (30HP, 85 kW system)

Cooling

Outdoor Unit Dry-Bulb (°C)		Outdoor Unit 100 % Cooling Capacity (kW)	Compressor + Outdoor Fan Power consumption (kW)							
			100 %		90 %		80 %		70 %	
			TC (kW)	PI (kW)	TC (kW)	PI (kW)	TC (kW)	PI (kW)	TC (kW)	PI (kW)
40	79.1	79.1	27.2	71.2	22.3	63.3	17.8	55.4	13.9	
39	80.4	80.4	26.8	72.3	21.9	64.3	17.6	56.3	13.7	
37	82.8	82.8	26.0	74.5	21.3	66.2	17.0	57.9	13.3	
35	85.0	85.0	25.2	76.5	20.6	68.0	16.5	59.5	12.9	
33	85.0	85.0	23.3	76.5	19.1	68.0	15.3	59.5	12.0	
31	85.0	85.0	21.6	76.5	17.7	68.0	14.2	59.5	11.1	
30	85.0	85.0	20.8	76.5	17.0	68.0	13.7	59.5	10.7	
29	85.0	85.0	20.1	76.5	16.4	68.0	13.2	59.5	10.4	
27	85.0	85.0	18.7	76.5	15.3	68.0	12.3	59.5	9.69	
25	85.0	85.0	17.4	76.5	14.3	68.0	11.5	59.5	9.07	
23	85.0	85.0	16.3	76.5	13.3	68.0	10.7	59.5	8.49	
21	85.0	85.0	15.9	76.5	13.0	68.0	10.5	59.5	8.32	
20	85.0	85.0	15.8	76.5	12.9	68.0	10.4	59.5	8.25	
19	85.0	85.0	15.6	76.5	12.8	68.0	10.3	59.5	8.18	
17	85.0	85.0	15.3	76.5	12.6	68.0	10.1	59.5	8.06	
15	85.0	85.0	15.1	76.5	12.4	68.0	9.99	59.5	7.95	

Outdoor Unit Dry-Bulb (°C)		Outdoor Unit 100 % Cooling Capacity (kW)	Compressor + Outdoor Fan Power consumption (kW)							
			60 %		50 %		40 %		30 %	
			TC (kW)	PI (kW)	TC (kW)	PI (kW)	TC (kW)	PI (kW)	TC (kW)	PI (kW)
40	79.1	47.5	10.7	39.5	8.18	31.6	6.44	23.7	5.55	
39	80.4	48.2	10.5	40.2	8.06	32.1	6.34	24.1	5.46	
37	82.8	49.7	10.2	41.4	7.82	33.1	6.15	24.8	5.30	
35	85.0	51.0	9.91	42.5	7.57	34.0	5.95	25.5	5.13	
33	85.0	51.0	9.22	42.5	7.10	34.0	5.65	25.5	4.94	
31	85.0	51.0	8.61	42.5	6.67	34.0	5.37	25.5	4.75	
30	85.0	51.0	8.33	42.5	6.48	34.0	5.23	25.5	4.65	
29	85.0	51.0	8.06	42.5	6.29	34.0	5.11	25.5	4.56	
27	85.0	51.0	7.56	42.5	5.93	34.0	4.86	25.5	4.38	
25	85.0	51.0	7.09	42.5	5.60	34.0	4.62	25.5	4.20	
23	85.0	51.0	6.66	42.5	5.28	34.0	4.39	25.5	4.02	
21	85.0	51.0	6.55	42.5	5.22	34.0	4.36	25.5	4.01	
20	85.0	51.0	6.50	42.5	5.19	34.0	4.34	25.5	4.01	
19	85.0	51.0	6.45	42.5	5.16	34.0	4.33	25.5	4.01	
17	85.0	51.0	6.37	42.5	5.11	34.0	4.31	25.5	4.01	
15	85.0	51.0	6.30	42.5	5.07	34.0	4.30	25.5	4.01	

TC : Total Capacity PI : Power Input
Indoor air temperature conditions : 27.0 °C dry-bulb / 19.0 °C wet bulb

Heating

Outdoor Unit Dry-Bulb (°C) Wet-Bulb (°C)			Outdoor Unit 100 % Heating Capacity (kW)	Compressor + Outdoor Fan Power consumption (kW)							
				100 %		90 %		80 %		70 %	
				TC (kW)	PI (kW)	TC (kW)	PI (kW)	TC (kW)	PI (kW)	TC (kW)	PI (kW)
15.0	13.7	95.0	95.0	21.2	85.5	17.5	76.0	14.4	66.5	11.8	
13.0	11.8	95.0	95.0	22.0	85.5	18.1	76.0	14.8	66.5	12.1	
11.0	9.8	95.0	95.0	23.0	85.5	18.9	76.0	15.4	66.5	12.5	
9.0	7.9	95.0	95.0	24.1	85.5	19.7	76.0	15.9	66.5	12.9	
7.0	6.0	95.0	95.0	25.4	85.5	20.6	76.0	16.6	66.5	13.3	
5.0	4.1	91.8	91.8	25.0	82.6	20.3	73.4	16.4	64.2	13.1	
3.0	2.2	88.5	88.5	24.6	79.6	20.0	70.8	16.1	61.9	12.9	
0.0	-0.7	83.3	83.3	24.0	75.0	19.5	66.7	15.7	58.3	12.6	
-3.0	-3.7	77.9	77.9	23.4	70.1	19.0	62.3	15.3	54.5	12.3	
-5.0	-5.6	74.3	74.3	23.0	66.9	18.7	59.5	15.1	52.0	12.1	
-7.0	-7.6	70.5	70.5	22.6	63.5	18.4	56.4	14.8	49.4	11.9	
-10	-10.5	64.9	64.9	22.0	58.4	17.9	51.9	14.4	45.4	11.6	
-14.5	-15.0	55.8	55.8	21.1	50.3	17.2	44.7	13.8	39.1	11.1	

Outdoor Unit Dry-Bulb (°C) Wet-Bulb (°C)			Outdoor Unit 100 % Heating Capacity (kW)	Compressor + Outdoor Fan Power consumption (kW)							
				60 %		50 %		40 %		30 %	
				TC (kW)	PI (kW)	TC (kW)	PI (kW)	TC (kW)	PI (kW)	TC (kW)	PI (kW)
15.0	13.7	95.0	57.0	9.70	47.5	8.02	38.0	6.70	28.5	5.70	
13.0	11.8	95.0	57.0	9.88	47.5	8.11	38.0	6.74	28.5	5.69	
11.0	9.8	95.0	57.0	10.1	47.5	8.24	38.0	6.78	28.5	5.69	
9.0	7.9	95.0	57.0	10.4	47.5	8.38	38.0	6.84	28.5	5.69	
7.0	6.0	95.0	57.0	10.7	47.5	8.54	38.0	6.92	28.5	5.71	
5.0	4.1	91.8	55.1	10.5	45.9	8.41	36.7	6.81	27.5	5.62	
3.0	2.2	88.5	53.1	10.3	44.2	8.28	35.4	6.71	26.5	5.53	
0.0	-0.7	83.3	50.0	10.1	41.7	8.09	33.3	6.55	25.0	5.40	
-3.0	-3.7	77.9	46.7	9.83	38.9	7.88	31.1	6.38	23.4	5.26	
-5.0	-5.6	74.3	44.6	9.66	37.2	7.75	29.7	6.28	22.3	5.18	
-7.0	-7.6	70.5	42.3	9.49	35.3	7.61	28.2	6.17	21.2	5.09	
-10	-10.5	64.9	38.9	9.25	32.4	7.42	26.0	6.01	19.5	4.95	
-14.5	-15.0	55.8	33.5	8.86	27.9	7.11	22.3	5.76	16.8	4.75	

TC : Total Capacity PI : Power Input
Indoor air temperature conditions : 20.0 °C dry-bulb



MMY-AP3214HT8P-E, AP3214T8P-E (32HP, 90 kW system)

Cooling

Outdoor Unit Dry-Bulb (°C)		Outdoor Unit 100 % Cooling Capacity (kW)	Compressor + Outdoor Fan Power consumption (kW)							
			100 %		90 %		80 %		70 %	
			TC (kW)	PI (kW)	TC (kW)	PI (kW)	TC (kW)	PI (kW)	TC (kW)	PI (kW)
40	83.8	83.8	29.6	75.4	24.3	67.0	19.4	58.6	15.1	
39	85.1	85.1	29.2	76.6	23.9	68.1	19.1	59.6	14.9	
37	87.6	87.6	28.3	78.9	23.2	70.1	18.5	61.3	14.4	
35	90.0	90.0	27.4	81.0	22.4	72.0	17.9	63.0	14.0	
33	90.0	90.0	25.3	81.0	20.7	72.0	16.6	63.0	12.9	
31	90.0	90.0	23.5	81.0	19.2	72.0	15.4	63.0	12.0	
30	90.0	90.0	22.6	81.0	18.5	72.0	14.8	63.0	11.6	
29	90.0	90.0	21.8	81.0	17.9	72.0	14.3	63.0	11.2	
27	90.0	90.0	20.3	81.0	16.7	72.0	13.3	63.0	10.4	
25	90.0	90.0	19.0	81.0	15.5	72.0	12.4	63.0	9.76	
23	90.0	90.0	17.7	81.0	14.5	72.0	11.6	63.0	9.13	
21	90.0	90.0	17.3	81.0	14.2	72.0	11.4	63.0	8.94	
20	90.0	90.0	17.2	81.0	14.0	72.0	11.3	63.0	8.86	
19	90.0	90.0	17.0	81.0	13.9	72.0	11.1	63.0	8.78	
17	90.0	90.0	16.7	81.0	13.7	72.0	11.0	63.0	8.65	
15	90.0	90.0	16.4	81.0	13.5	72.0	10.80	63.0	8.53	

Outdoor Unit Dry-Bulb (°C)		Outdoor Unit 100 % Cooling Capacity (kW)	Compressor + Outdoor Fan Power consumption (kW)							
			60 %		50 %		40 %		30 %	
			TC (kW)	PI (kW)	TC (kW)	PI (kW)	TC (kW)	PI (kW)	TC (kW)	PI (kW)
40	83.8	50.3	11.5	41.9	8.68	33.5	6.79	25.1	5.93	
39	85.1	51.1	11.3	42.5	8.55	34.0	6.69	25.5	5.84	
37	87.6	52.6	11.0	43.8	8.29	35.1	6.49	26.3	5.67	
35	90.0	54.0	10.6	45.0	8.03	36.0	6.28	27.0	5.49	
33	90.0	54.0	9.88	45.0	7.52	36.0	5.96	27.0	5.29	
31	90.0	54.0	9.21	45.0	7.07	36.0	5.67	27.0	5.10	
30	90.0	54.0	8.90	45.0	6.86	36.0	5.53	27.0	5.00	
29	90.0	54.0	8.61	45.0	6.65	36.0	5.39	27.0	4.90	
27	90.0	54.0	8.06	45.0	6.27	36.0	5.13	27.0	4.72	
25	90.0	54.0	7.56	45.0	5.92	36.0	4.88	27.0	4.53	
23	90.0	54.0	7.10	45.0	5.58	36.0	4.64	27.0	4.34	
21	90.0	54.0	6.97	45.0	5.51	36.0	4.61	27.0	4.34	
20	90.0	54.0	6.92	45.0	5.48	36.0	4.60	27.0	4.34	
19	90.0	54.0	6.86	45.0	5.45	36.0	4.59	27.0	4.34	
17	90.0	54.0	6.77	45.0	5.40	36.0	4.57	27.0	4.34	
15	90.0	54.0	6.70	45.0	5.35	36.0	4.55	27.0	4.34	

TC : Total Capacity PI : Power Input
Indoor air temperature conditions : 27.0 °C dry-bulb / 19.0 °C wet bulb

Heating

Outdoor Unit Dry-Bulb (°C) Wet-Bulb (°C) Heating Capacity (kW)			Compressor + Outdoor Fan Power consumption (kW)							
			100 %		90 %		80 %		70 %	
			TC (kW)	PI (kW)	TC (kW)	PI (kW)	TC (kW)	PI (kW)	TC (kW)	PI (kW)
15.0	13.7	100.0	100.0	23.7	90.0	19.5	80.0	15.8	70.0	12.8
13.0	11.8	100.0	100.0	24.7	90.0	20.2	80.0	16.4	70.0	13.2
11.0	9.8	100.0	100.0	25.8	90.0	21.1	80.0	17.0	70.0	13.6
9.0	7.9	100.0	100.0	27.0	90.0	22.0	80.0	17.7	70.0	14.1
7.0	6.0	100.0	100.0	28.4	90.0	23.1	80.0	18.5	70.0	14.7
5.0	4.1	96.6	96.6	28.0	86.9	22.7	77.3	18.2	67.6	14.4
3.0	2.2	93.1	93.1	27.5	83.8	22.4	74.5	18.0	65.2	14.2
0.0	-0.7	87.7	87.7	26.9	79.0	21.9	70.2	17.5	61.4	13.9
-3.0	-3.7	82.0	82.0	26.2	73.8	21.3	65.6	17.1	57.4	13.5
-5.0	-5.6	78.2	78.2	25.8	70.4	21.0	62.6	16.8	54.8	13.3
-7.0	-7.6	74.2	74.2	25.3	66.8	20.6	59.4	16.5	52.0	13.1
-10	-10.5	68.3	68.3	24.6	61.5	20.0	54.6	16.1	47.8	12.7
-14.5	-15.0	58.8	58.8	23.6	52.9	19.2	47.0	15.4	41.1	12.2

Outdoor Unit Dry-Bulb (°C) Wet-Bulb (°C) Heating Capacity (kW)			Compressor + Outdoor Fan Power consumption (kW)							
			60 %		50 %		40 %		30 %	
			TC (kW)	PI (kW)	TC (kW)	PI (kW)	TC (kW)	PI (kW)	TC (kW)	PI (kW)
15.0	13.7	100.0	60.0	10.4	50.0	8.51	40.0	7.25	30.0	6.60
13.0	11.8	100.0	60.0	10.6	50.0	8.61	40.0	7.26	30.0	6.53
11.0	9.8	100.0	60.0	10.9	50.0	8.74	40.0	7.28	30.0	6.48
9.0	7.9	100.0	60.0	11.2	50.0	8.90	40.0	7.32	30.0	6.43
7.0	6.0	100.0	60.0	11.5	50.0	9.09	40.0	7.38	30.0	6.39
5.0	4.1	96.6	58.0	11.3	48.3	8.95	38.6	7.27	29.0	6.29
3.0	2.2	93.1	55.9	11.2	46.6	8.81	37.3	7.16	27.9	6.20
0.0	-0.7	87.7	52.6	10.9	43.9	8.60	35.1	6.98	26.3	6.05
-3.0	-3.7	82.0	49.2	10.6	41.0	8.38	32.8	6.81	24.6	5.89
-5.0	-5.6	78.2	46.9	10.4	39.1	8.24	31.3	6.69	23.5	5.80
-7.0	-7.6	74.2	44.5	10.3	37.1	8.10	29.7	6.58	22.3	5.69
-10	-10.5	68.3	41.0	9.99	34.1	7.89	27.3	6.41	20.5	5.55
-14.5	-15.0	58.8	35.3	9.58	29.4	7.56	23.5	6.14	17.6	5.32

TC : Total Capacity PI : Power Input
Indoor air temperature conditions : 20.0 °C dry-bulb



MMY-AP3414HT8P-E, AP3414T8P-E (34HP, 96 kW system)

Cooling

Outdoor Unit Dry-Bulb (°C)		Outdoor Unit 100 % Cooling Capacity (kW)	Compressor + Outdoor Fan Power consumption (kW)							
			100 %		90 %		80 %		70 %	
			TC (kW)	PI (kW)	TC (kW)	PI (kW)	TC (kW)	PI (kW)	TC (kW)	PI (kW)
40	89.3	89.3	29.2	80.4	23.9	71.5	19.3	62.5	15.3	
39	90.8	90.8	28.8	81.7	23.6	72.6	19.0	63.5	15.1	
37	93.5	93.5	27.9	84.1	22.8	74.8	18.4	65.4	14.7	
35	96.0	96.0	27.1	86.4	22.1	76.8	17.8	67.2	14.2	
33	96.0	96.0	25.0	86.4	20.5	76.8	16.5	67.2	13.2	
31	96.0	96.0	23.1	86.4	19.0	76.8	15.4	67.2	12.3	
30	96.0	96.0	22.3	86.4	18.3	76.8	14.9	67.2	11.9	
29	96.0	96.0	21.5	86.4	17.7	76.8	14.4	67.2	11.5	
27	96.0	96.0	20.0	86.4	16.5	76.8	13.4	67.2	10.8	
25	96.0	96.0	18.7	86.4	15.4	76.8	12.6	67.2	10.1	
23	96.0	96.0	17.5	86.4	14.4	76.8	11.8	67.2	9.49	
21	96.0	96.0	17.1	86.4	14.1	76.8	11.5	67.2	9.32	
20	96.0	96.0	16.9	86.4	14.0	76.8	11.4	67.2	9.25	
19	96.0	96.0	16.8	86.4	13.9	76.8	11.3	67.2	9.18	
17	96.0	96.0	16.5	86.4	13.6	76.8	11.2	67.2	9.06	
15	96.0	96.0	16.2	86.4	13.4	76.8	11.0	67.2	8.95	

Outdoor Unit Dry-Bulb (°C)		Outdoor Unit 100 % Cooling Capacity (kW)	Compressor + Outdoor Fan Power consumption (kW)							
			60 %		50 %		40 %		30 %	
			TC (kW)	PI (kW)	TC (kW)	PI (kW)	TC (kW)	PI (kW)	TC (kW)	PI (kW)
40	89.3	53.6	12.1	44.7	9.46	35.7	7.53	26.8	6.28	
39	90.8	54.5	11.9	45.4	9.32	36.3	7.42	27.2	6.19	
37	93.5	56.1	11.5	46.7	9.04	37.4	7.20	28.0	6.00	
35	96.0	57.6	11.2	48.0	8.75	38.4	6.97	28.8	5.81	
33	96.0	57.6	10.4	48.0	8.23	38.4	6.61	28.8	5.56	
31	96.0	57.6	9.77	48.0	7.76	38.4	6.28	28.8	5.33	
30	96.0	57.6	9.46	48.0	7.53	38.4	6.12	28.8	5.21	
29	96.0	57.6	9.17	48.0	7.32	38.4	5.96	28.8	5.10	
27	96.0	57.6	8.62	48.0	6.91	38.4	5.66	28.8	4.87	
25	96.0	57.6	8.11	48.0	6.53	38.4	5.38	28.8	4.66	
23	96.0	57.6	7.63	48.0	6.17	38.4	5.10	28.8	4.44	
21	96.0	57.6	7.51	48.0	6.09	38.4	5.06	28.8	4.42	
20	96.0	57.6	7.46	48.0	6.06	38.4	5.05	28.8	4.42	
19	96.0	57.6	7.41	48.0	6.03	38.4	5.03	28.8	4.41	
17	96.0	57.6	7.33	48.0	5.98	38.4	5.00	28.8	4.40	
15	96.0	57.6	7.26	48.0	5.93	38.4	4.98	28.8	4.39	

TC : Total Capacity PI : Power Input
Indoor air temperature conditions : 27.0 °C dry-bulb / 19.0 °C wet bulb

Heating

Outdoor Unit Dry-Bulb (°C)		Outdoor Unit 100 % Heating Capacity (kW)	Compressor + Outdoor Fan Power consumption (kW)							
			100 %		90 %		80 %		70 %	
			TC (kW)	PI (kW)	TC (kW)	PI (kW)	TC (kW)	PI (kW)	TC (kW)	PI (kW)
15.0	13.7	108.0	108.0	23.8	97.2	19.7	86.4	16.3	75.6	13.5
13.0	11.8	108.0	108.0	24.8	97.2	20.4	86.4	16.8	75.6	13.8
11.0	9.8	108.0	108.0	25.9	97.2	21.3	86.4	17.4	75.6	14.2
9.0	7.9	108.0	108.0	27.2	97.2	22.2	86.4	18.0	75.6	14.6
7.0	6.0	108.0	108.0	28.6	97.2	23.2	86.4	18.8	75.6	15.1
5.0	4.1	104.3	104.3	28.2	93.9	22.9	83.5	18.5	73.0	14.9
3.0	2.2	100.6	100.6	27.7	90.5	22.5	80.5	18.2	70.4	14.7
0.0	-0.7	94.7	94.7	27.1	85.3	22.0	75.8	17.8	66.3	14.3
-3.0	-3.7	88.5	88.5	26.4	79.7	21.4	70.8	17.3	62.0	14.0
-5.0	-5.6	84.5	84.5	25.9	76.0	21.1	67.6	17.0	59.1	13.7
-7.0	-7.6	80.2	80.2	25.5	72.2	20.7	64.1	16.7	56.1	13.5
-10	-10.5	73.8	73.8	24.8	66.4	20.1	59.0	16.3	51.6	13.1
-14.5	-15.0	63.5	63.5	23.8	57.1	19.3	50.8	15.6	44.4	12.6

Outdoor Unit Dry-Bulb (°C)		Outdoor Unit 100 % Heating Capacity (kW)	Compressor + Outdoor Fan Power consumption (kW)							
			60 %		50 %		40 %		30 %	
			TC (kW)	PI (kW)	TC (kW)	PI (kW)	TC (kW)	PI (kW)	TC (kW)	PI (kW)
15.0	13.7	108.0	64.8	11.2	54.0	9.24	43.2	7.65	32.4	6.30
13.0	11.8	108.0	64.8	11.4	54.0	9.35	43.2	7.70	32.4	6.31
11.0	9.8	108.0	64.8	11.6	54.0	9.50	43.2	7.77	32.4	6.34
9.0	7.9	108.0	64.8	11.9	54.0	9.66	43.2	7.86	32.4	6.37
7.0	6.0	108.0	64.8	12.2	54.0	9.85	43.2	7.96	32.4	6.41
5.0	4.1	104.3	62.6	12.0	52.2	9.70	41.7	7.83	31.3	6.31
3.0	2.2	100.6	60.4	11.8	50.3	9.55	40.2	7.71	30.2	6.21
0.0	-0.7	94.7	56.8	11.5	47.4	9.32	37.9	7.53	28.4	6.07
-3.0	-3.7	88.5	53.1	11.3	44.3	9.08	35.4	7.34	26.6	5.91
-5.0	-5.6	84.5	50.7	11.1	42.2	8.93	33.8	7.22	25.3	5.81
-7.0	-7.6	80.2	48.1	10.9	40.1	8.77	32.1	7.09	24.1	5.71
-10	-10.5	73.8	44.3	10.6	36.9	8.55	29.5	6.90	22.1	5.56
-14.5	-15.0	63.5	38.1	10.1	31.7	8.19	25.4	6.62	19.0	5.33

TC : Total Capacity PI : Power Input
Indoor air temperature conditions : 20.0 °C dry-bulb



MMY-AP3614HT8P-E, AP3614T8P-E (36HP, 101 kW system)

Cooling

Outdoor Unit Dry-Bulb (°C)		Outdoor Unit 100 % Cooling Capacity (kW)	Compressor + Outdoor Fan Power consumption (kW)							
			100 %		90 %		80 %		70 %	
			TC (kW)	PI (kW)	TC (kW)	PI (kW)	TC (kW)	PI (kW)	TC (kW)	PI (kW)
40	94.0	94.0	31.2	84.6	25.5	75.2	20.5	65.8	16.2	
39	95.5	95.5	30.8	85.9	25.1	76.4	20.2	66.8	16.0	
37	98.3	98.3	29.8	88.5	24.3	78.7	19.6	68.8	15.5	
35	101.0	101.0	28.9	90.9	23.6	80.8	18.9	70.7	15.0	
33	101.0	101.0	26.7	90.9	21.8	80.8	17.6	70.7	14.0	
31	101.0	101.0	24.7	90.9	20.2	80.8	16.3	70.7	13.0	
30	101.0	101.0	23.8	90.9	19.5	80.8	15.8	70.7	12.6	
29	101.0	101.0	23.0	90.9	18.8	80.8	15.2	70.7	12.2	
27	101.0	101.0	21.4	90.9	17.5	80.8	14.2	70.7	11.4	
25	101.0	101.0	19.9	90.9	16.4	80.8	13.3	70.7	10.7	
23	101.0	101.0	18.6	90.9	15.3	80.8	12.4	70.7	10.0	
21	101.0	101.0	18.2	90.9	15.0	80.8	12.2	70.7	9.86	
20	101.0	101.0	18.0	90.9	14.8	80.8	12.1	70.7	9.78	
19	101.0	101.0	17.8	90.9	14.7	80.8	12.0	70.7	9.70	
17	101.0	101.0	17.5	90.9	14.5	80.8	11.8	70.7	9.57	
15	101.0	101.0	17.3	90.9	14.3	80.8	11.7	70.7	9.46	

Outdoor Unit Dry-Bulb (°C)		Outdoor Unit 100 % Cooling Capacity (kW)	Compressor + Outdoor Fan Power consumption (kW)							
			60 %		50 %		40 %		30 %	
			TC (kW)	PI (kW)	TC (kW)	PI (kW)	TC (kW)	PI (kW)	TC (kW)	PI (kW)
40	94.0	56.4	12.7	47.0	10.0	37.6	7.97	28.2	6.65	
39	95.5	57.3	12.6	47.7	9.85	38.2	7.85	28.6	6.55	
37	98.3	59.0	12.2	49.2	9.55	39.3	7.62	29.5	6.35	
35	101.0	60.6	11.8	50.5	9.25	40.4	7.38	30.3	6.15	
33	101.0	60.6	11.0	50.5	8.70	40.4	7.00	30.3	5.89	
31	101.0	60.6	10.3	50.5	8.20	40.4	6.64	30.3	5.64	
30	101.0	60.6	10.0	50.5	7.96	40.4	6.47	30.3	5.52	
29	101.0	60.6	9.69	50.5	7.74	40.4	6.31	30.3	5.40	
27	101.0	60.6	9.11	50.5	7.31	40.4	5.99	30.3	5.16	
25	101.0	60.6	8.57	50.5	6.91	40.4	5.69	30.3	4.93	
23	101.0	60.6	8.06	50.5	6.52	40.4	5.40	30.3	4.70	
21	101.0	60.6	7.94	50.5	6.45	40.4	5.36	30.3	4.68	
20	101.0	60.6	7.89	50.5	6.41	40.4	5.34	30.3	4.67	
19	101.0	60.6	7.84	50.5	6.38	40.4	5.33	30.3	4.67	
17	101.0	60.6	7.75	50.5	6.32	40.4	5.29	30.3	4.65	
15	101.0	60.6	7.67	50.5	6.27	40.4	5.27	30.3	4.64	

TC : Total Capacity PI : Power Input
Indoor air temperature conditions : 27.0 °C dry-bulb / 19.0 °C wet bulb

Heating

Outdoor Unit Dry-Bulb (°C) Wet-Bulb (°C)			Outdoor Unit 100 % Heating Capacity (kW)	Compressor + Outdoor Fan Power consumption (kW)							
				100 %		90 %		80 %		70 %	
				TC (kW)	PI (kW)	TC (kW)	PI (kW)	TC (kW)	PI (kW)	TC (kW)	PI (kW)
15.0	13.7	113.0	113.0	25.7	101.7	21.3	90.4	17.6	79.1	14.4	
13.0	11.8	113.0	113.0	26.7	101.7	22.0	90.4	18.1	79.1	14.8	
11.0	9.8	113.0	113.0	28.0	101.7	22.9	90.4	18.7	79.1	15.2	
9.0	7.9	113.0	113.0	29.3	101.7	23.9	90.4	19.4	79.1	15.7	
7.0	6.0	113.0	113.0	30.8	101.7	25.1	90.4	20.2	79.1	16.3	
5.0	4.1	109.2	109.2	30.4	98.2	24.7	87.3	19.9	76.4	16.0	
3.0	2.2	105.2	105.2	29.9	94.7	24.3	84.2	19.6	73.7	15.8	
0.0	-0.7	99.1	99.1	29.2	89.2	23.7	79.3	19.1	69.4	15.4	
-3.0	-3.7	92.6	92.6	28.4	83.4	23.1	74.1	18.7	64.8	15.0	
-5.0	-5.6	88.4	88.4	28.0	79.6	22.7	70.7	18.4	61.9	14.8	
-7.0	-7.6	83.9	83.9	27.5	75.5	22.3	67.1	18.0	58.7	14.5	
-10	-10.5	77.2	77.2	26.8	69.5	21.7	61.7	17.6	54.0	14.1	
-14.5	-15.0	66.4	66.4	25.7	59.8	20.8	53.1	16.8	46.5	13.5	

Outdoor Unit Dry-Bulb (°C) Wet-Bulb (°C)			Outdoor Unit 100 % Heating Capacity (kW)	Compressor + Outdoor Fan Power consumption (kW)							
				60 %		50 %		40 %		30 %	
				TC (kW)	PI (kW)	TC (kW)	PI (kW)	TC (kW)	PI (kW)	TC (kW)	PI (kW)
15.0	13.7	113.0	67.8	11.9	56.5	9.83	45.2	8.17	33.9	6.85	
13.0	11.8	113.0	67.8	12.1	56.5	9.95	45.2	8.22	33.9	6.85	
11.0	9.8	113.0	67.8	12.4	56.5	10.1	45.2	8.29	33.9	6.86	
9.0	7.9	113.0	67.8	12.7	56.5	10.3	45.2	8.37	33.9	6.88	
7.0	6.0	113.0	67.8	13.0	56.5	10.5	45.2	8.47	33.9	6.91	
5.0	4.1	109.2	65.5	12.8	54.6	10.3	43.7	8.34	32.7	6.80	
3.0	2.2	105.2	63.1	12.7	52.6	10.2	42.1	8.21	31.6	6.70	
0.0	-0.7	99.1	59.5	12.3	49.6	9.92	39.7	8.02	29.7	6.54	
-3.0	-3.7	92.6	55.6	12.0	46.3	9.67	37.0	7.82	27.8	6.37	
-5.0	-5.6	88.4	53.0	11.8	44.2	9.51	35.4	7.69	26.5	6.27	
-7.0	-7.6	83.9	50.3	11.6	41.9	9.34	33.6	7.55	25.2	6.16	
-10	-10.5	77.2	46.3	11.3	38.6	9.10	30.9	7.35	23.2	6.00	
-14.5	-15.0	66.4	39.9	10.9	33.2	8.72	26.6	7.05	19.9	5.75	

TC : Total Capacity PI : Power Input
Indoor air temperature conditions : 20.0 °C dry-bulb



MMY-AP3814HT8P-E, AP3814T8P-E (38HP, 106.5 kW system)

Cooling

Outdoor Unit Dry-Bulb (°C)		Outdoor Unit 100 % Cooling Capacity (kW)	Compressor + Outdoor Fan Power consumption (kW)							
			100 %		90 %		80 %		70 %	
			TC (kW)	PI (kW)	TC (kW)	PI (kW)	TC (kW)	PI (kW)	TC (kW)	PI (kW)
40	99.1	99.1	33.1	89.2	27.1	79.3	21.8	69.4	17.2	
39	100.7	100.7	32.6	90.6	26.7	80.6	21.5	70.5	17.0	
37	103.7	103.7	31.6	93.3	25.9	83.0	20.8	72.6	16.5	
35	106.5	106.5	30.7	95.9	25.1	85.2	20.2	74.6	16.0	
33	106.5	106.5	28.3	95.9	23.2	85.2	18.7	74.6	14.8	
31	106.5	106.5	26.3	95.9	21.5	85.2	17.4	74.6	13.8	
30	106.5	106.5	25.3	95.9	20.8	85.2	16.8	74.6	13.3	
29	106.5	106.5	24.4	95.9	20.0	85.2	16.2	74.6	12.9	
27	106.5	106.5	22.7	95.9	18.7	85.2	15.1	74.6	12.1	
25	106.5	106.5	21.2	95.9	17.4	85.2	14.1	74.6	11.3	
23	106.5	106.5	19.8	95.9	16.3	85.2	13.2	74.6	10.6	
21	106.5	106.5	19.4	95.9	16.0	85.2	13.0	74.6	10.4	
20	106.5	106.5	19.2	95.9	15.8	85.2	12.8	74.6	10.3	
19	106.5	106.5	19.0	95.9	15.7	85.2	12.7	74.6	10.2	
17	106.5	106.5	18.7	95.9	15.4	85.2	12.5	74.6	10.1	
15	106.5	106.5	18.4	95.9	15.2	85.2	12.4	74.6	9.97	

Outdoor Unit Dry-Bulb (°C)		Outdoor Unit 100 % Cooling Capacity (kW)	Compressor + Outdoor Fan Power consumption (kW)							
			60 %		50 %		40 %		30 %	
			TC (kW)	PI (kW)	TC (kW)	PI (kW)	TC (kW)	PI (kW)	TC (kW)	PI (kW)
40	99.1	59.5	13.4	49.6	10.4	39.6	8.28	29.7	6.99	
39	100.7	60.4	13.2	50.3	10.3	40.3	8.15	30.2	6.89	
37	103.7	62.2	12.8	51.9	9.97	41.5	7.91	31.1	6.68	
35	106.5	63.9	12.4	53.3	9.66	42.6	7.66	32.0	6.47	
33	106.5	63.9	11.6	53.3	9.07	42.6	7.26	32.0	6.21	
31	106.5	63.9	10.9	53.3	8.54	42.6	6.90	32.0	5.95	
30	106.5	63.9	10.5	53.3	8.29	42.6	6.72	32.0	5.83	
29	106.5	63.9	10.2	53.3	8.05	42.6	6.56	32.0	5.71	
27	106.5	63.9	9.56	53.3	7.60	42.6	6.23	32.0	5.47	
25	106.5	63.9	8.98	53.3	7.18	42.6	5.92	32.0	5.23	
23	106.5	63.9	8.45	53.3	6.78	42.6	5.62	32.0	4.99	
21	106.5	63.9	8.31	53.3	6.70	42.6	5.58	32.0	4.98	
20	106.5	63.9	8.25	53.3	6.66	42.6	5.56	32.0	4.97	
19	106.5	63.9	8.20	53.3	6.63	42.6	5.55	32.0	4.97	
17	106.5	63.9	8.10	53.3	6.57	42.6	5.52	32.0	4.96	
15	106.5	63.9	8.02	53.3	6.52	42.6	5.49	32.0	4.95	

TC : Total Capacity PI : Power Input
Indoor air temperature conditions : 27.0 °C dry-bulb / 19.0 °C wet bulb

Heating

Outdoor Unit Dry-Bulb (°C)		Outdoor Unit Wet-Bulb (°C)	Outdoor Unit 100 % Heating Capacity (kW)	Compressor + Outdoor Fan Power consumption (kW)							
				100 %		90 %		80 %		70 %	
				TC (kW)	PI (kW)	TC (kW)	PI (kW)	TC (kW)	PI (kW)	TC (kW)	PI (kW)
15.0	13.7	119.5	119.5	26.8	107.6	22.1	95.6	18.2	83.7	15.0	
13.0	11.8	119.5	119.5	27.9	107.6	22.9	95.6	18.8	83.7	15.3	
11.0	9.8	119.5	119.5	29.1	107.6	23.9	95.6	19.5	83.7	15.8	
9.0	7.9	119.5	119.5	30.5	107.6	24.9	95.6	20.2	83.7	16.3	
7.0	6.0	119.5	119.5	32.1	107.6	26.1	95.6	21.0	83.7	16.9	
5.0	4.1	115.4	115.4	31.6	103.9	25.7	92.4	20.7	80.8	16.6	
3.0	2.2	111.3	111.3	31.2	100.2	25.3	89.0	20.4	77.9	16.4	
0.0	-0.7	104.8	104.8	30.4	94.4	24.7	83.9	19.9	73.4	16.0	
-3.0	-3.7	98.0	98.0	29.6	88.2	24.1	78.4	19.4	68.6	15.6	
-5.0	-5.6	93.5	93.5	29.2	84.1	23.7	74.8	19.1	65.4	15.3	
-7.0	-7.6	88.7	88.7	28.6	79.8	23.3	71.0	18.8	62.1	15.0	
-10	-10.5	81.6	81.6	27.9	73.5	22.7	65.3	18.3	57.1	14.7	
-14.5	-15.0	70.2	70.2	26.7	63.2	21.7	56.2	17.5	49.2	14.0	

Outdoor Unit Dry-Bulb (°C)		Outdoor Unit Wet-Bulb (°C)	Outdoor Unit 100 % Heating Capacity (kW)	Compressor + Outdoor Fan Power consumption (kW)							
				60 %		50 %		40 %		30 %	
				TC (kW)	PI (kW)	TC (kW)	PI (kW)	TC (kW)	PI (kW)	TC (kW)	PI (kW)
15.0	13.7	119.5	71.7	12.3	59.8	10.2	47.8	8.49	35.9	7.19	
13.0	11.8	119.5	71.7	12.5	59.8	10.3	47.8	8.54	35.9	7.18	
11.0	9.8	119.5	71.7	12.8	59.8	10.5	47.8	8.60	35.9	7.18	
9.0	7.9	119.5	71.7	13.1	59.8	10.6	47.8	8.68	35.9	7.19	
7.0	6.0	119.5	71.7	13.5	59.8	10.8	47.8	8.78	35.9	7.21	
5.0	4.1	115.4	69.3	13.3	57.7	10.7	46.2	8.65	34.6	7.10	
3.0	2.2	111.3	66.8	13.1	55.7	10.5	44.5	8.51	33.4	6.99	
0.0	-0.7	104.8	62.9	12.8	52.4	10.3	41.9	8.31	31.5	6.83	
-3.0	-3.7	98.0	58.8	12.5	49.0	10.0	39.2	8.10	29.4	6.65	
-5.0	-5.6	93.5	56.1	12.3	46.7	9.84	37.4	7.97	28.0	6.54	
-7.0	-7.6	88.7	53.2	12.0	44.4	9.67	35.5	7.82	26.6	6.43	
-10	-10.5	81.6	49.0	11.7	40.8	9.42	32.6	7.62	24.5	6.26	
-14.5	-15.0	70.2	42.1	11.2	35.1	9.03	28.1	7.31	21.1	6.00	

TC : Total Capacity PI : Power Input
Indoor air temperature conditions : 20.0 °C dry-bulb



MMY-AP4014HT8P-E, AP4014T8P-E (40HP, 112 kW system)

Cooling

Outdoor Unit Dry-Bulb (°C)		Outdoor Unit 100 % Cooling Capacity (kW)	Compressor + Outdoor Fan Power consumption (kW)							
			100 %		90 %		80 %		70 %	
			TC (kW)	PI (kW)	TC (kW)	PI (kW)	TC (kW)	PI (kW)	TC (kW)	PI (kW)
40	104.2	104.2	35.4	93.8	28.9	83.4	23.2	73.0	18.3	
39	105.9	105.9	34.9	95.3	28.5	84.7	22.9	74.1	18.0	
37	109.1	109.1	33.8	98.2	27.6	87.2	22.2	76.3	17.5	
35	112.0	112.0	32.8	100.8	26.8	89.6	21.5	78.4	16.9	
33	112.0	112.0	30.3	100.8	24.7	89.6	19.9	78.4	15.7	
31	112.0	112.0	28.1	100.8	23.0	89.6	18.5	78.4	14.6	
30	112.0	112.0	27.0	100.8	22.1	89.6	17.8	78.4	14.1	
29	112.0	112.0	26.1	100.8	21.3	89.6	17.2	78.4	13.7	
27	112.0	112.0	24.3	100.8	19.9	89.6	16.1	78.4	12.8	
25	112.0	112.0	22.6	100.8	18.6	89.6	15.0	78.4	12.0	
23	112.0	112.0	21.1	100.8	17.4	89.6	14.0	78.4	11.2	
21	112.0	112.0	20.7	100.8	17.0	89.6	13.8	78.4	11.0	
20	112.0	112.0	20.5	100.8	16.8	89.6	13.6	78.4	10.9	
19	112.0	112.0	20.3	100.8	16.7	89.6	13.5	78.4	10.8	
17	112.0	112.0	19.9	100.8	16.4	89.6	13.3	78.4	10.7	
15	112.0	112.0	19.6	100.8	16.15	89.6	13.1	78.4	10.6	

Outdoor Unit Dry-Bulb (°C)		Outdoor Unit 100 % Cooling Capacity (kW)	Compressor + Outdoor Fan Power consumption (kW)							
			60 %		50 %		40 %		30 %	
			TC (kW)	PI (kW)	TC (kW)	PI (kW)	TC (kW)	PI (kW)	TC (kW)	PI (kW)
40	104.2	62.5	14.2	52.1	11.0	41.7	8.74	31.3	7.39	
39	105.9	63.5	14.0	52.9	10.9	42.4	8.6	31.8	7.28	
37	109.1	65.4	13.6	54.5	10.5	43.6	8.35	32.7	7.06	
35	112.0	67.2	13.2	56.0	10.2	44.8	8.08	33.6	6.84	
33	112.0	67.2	12.3	56.0	9.58	44.8	7.67	33.6	6.56	
31	112.0	67.2	11.5	56.0	9.02	44.8	7.28	33.6	6.30	
30	112.0	67.2	11.1	56.0	8.76	44.8	7.10	33.6	6.16	
29	112.0	67.2	10.8	56.0	8.50	44.8	6.92	33.6	6.04	
27	112.0	67.2	10.1	56.0	8.03	44.8	6.58	33.6	5.78	
25	112.0	67.2	9.49	56.0	7.58	44.8	6.25	33.6	5.53	
23	112.0	67.2	8.93	56.0	7.16	44.8	5.94	33.6	5.28	
21	112.0	67.2	8.78	56.0	7.07	44.8	5.89	33.6	5.27	
20	112.0	67.2	8.72	56.0	7.03	44.8	5.87	33.6	5.26	
19	112.0	67.2	8.66	56.0	7.00	44.8	5.86	33.6	5.26	
17	112.0	67.2	8.56	56.0	6.93	44.8	5.82	33.6	5.25	
15	112.0	67.2	8.47	56.0	6.88	44.8	5.80	33.6	5.24	

TC : Total Capacity PI : Power Input
Indoor air temperature conditions : 27.0 °C dry-bulb / 19.0 °C wet bulb

Heating

Outdoor Unit Dry-Bulb (°C) Wet-Bulb (°C)			Outdoor Unit 100 % Heating Capacity (kW)	Compressor + Outdoor Fan Power consumption (kW)							
				100 %		90 %		80 %		70 %	
				TC (kW)	PI (kW)	TC (kW)	PI (kW)	TC (kW)	PI (kW)	TC (kW)	PI (kW)
15.0	13.7	127.0	127.0	29.5	114.3	24.3	101.6	20.0	88.9	16.3	
13.0	11.8	127.0	127.0	30.6	114.3	25.2	101.6	20.6	88.9	16.7	
11.0	9.8	127.0	127.0	32.0	114.3	26.2	101.6	21.3	88.9	17.3	
9.0	7.9	127.0	127.0	33.5	114.3	27.4	101.6	22.2	88.9	17.8	
7.0	6.0	127.0	127.0	35.3	114.3	28.7	101.6	23.1	88.9	18.5	
5.0	4.1	122.7	122.7	34.8	110.4	28.2	98.1	22.8	85.9	18.2	
3.0	2.2	118.3	118.3	34.2	106.5	27.8	94.6	22.4	82.8	17.9	
0.0	-0.7	111.4	111.4	33.4	100.3	27.1	89.1	21.9	78.0	17.5	
-3.0	-3.7	104.1	104.1	32.5	93.7	26.5	83.3	21.3	72.9	17.0	
-5.0	-5.6	99.4	99.4	32.0	89.4	26.0	79.5	21.0	69.5	16.8	
-7.0	-7.6	94.3	94.3	31.4	84.8	25.6	75.4	20.6	66.0	16.5	
-10	-10.5	86.7	86.7	30.6	78.1	24.9	69.4	20.1	60.7	16.0	
-14.5	-15.0	74.6	74.6	29.4	67.2	23.9	59.7	19.2	52.3	15.4	

Outdoor Unit Dry-Bulb (°C) Wet-Bulb (°C)			Outdoor Unit 100 % Heating Capacity (kW)	Compressor + Outdoor Fan Power consumption (kW)							
				60 %		50 %		40 %		30 %	
				TC (kW)	PI (kW)	TC (kW)	PI (kW)	TC (kW)	PI (kW)	TC (kW)	PI (kW)
15.0	13.7	127.0	76.2	13.4	63.5	11.0	50.8	9.24	38.1	7.96	
13.0	11.8	127.0	76.2	13.6	63.5	11.2	50.8	9.28	38.1	7.93	
11.0	9.8	127.0	76.2	13.9	63.5	11.3	50.8	9.34	38.1	7.92	
9.0	7.9	127.0	76.2	14.3	63.5	11.5	50.8	9.42	38.1	7.91	
7.0	6.0	127.0	76.2	14.7	63.5	11.8	50.8	9.52	38.1	7.92	
5.0	4.1	122.7	73.6	14.5	61.3	11.6	49.1	9.38	36.8	7.80	
3.0	2.2	118.3	71.0	14.3	59.1	11.4	47.3	9.23	35.5	7.68	
0.0	-0.7	111.4	66.8	13.9	55.7	11.1	44.6	9.01	33.4	7.49	
-3.0	-3.7	104.1	62.5	13.6	52.0	10.9	41.6	8.78	31.2	7.30	
-5.0	-5.6	99.4	59.6	13.4	49.7	10.7	39.7	8.64	29.8	7.18	
-7.0	-7.6	94.3	56.6	13.1	47.1	10.5	37.7	8.48	28.3	7.06	
-10	-10.5	86.7	52.0	12.8	43.4	10.2	34.7	8.26	26.0	6.87	
-14.5	-15.0	74.6	44.8	12.25	37.3	9.79	29.9	7.92	22.4	6.59	

TC : Total Capacity PI : Power Input
Indoor air temperature conditions : 20.0 °C dry-bulb



MMY-AP4214HT8P-E, AP4214T8P-E (42HP, 118 kW system)

Cooling

Outdoor Unit Dry-Bulb (°C)		Outdoor Unit 100 % Cooling Capacity (kW)	Compressor + Outdoor Fan Power consumption (kW)							
			100 %		90 %		80 %		70 %	
			TC (kW)	PI (kW)	TC (kW)	PI (kW)	TC (kW)	PI (kW)	TC (kW)	PI (kW)
40	109.8	109.8	37.2	98.8	30.4	87.8	24.4	76.9	19.2	
39	111.6	111.6	36.7	100.4	30.0	89.3	24.0	78.1	18.9	
37	114.9	114.9	35.6	103.4	29.1	91.9	23.3	80.4	18.3	
35	118.0	118.0	34.5	106.2	28.2	94.4	22.6	82.6	17.7	
33	118.0	118.0	31.8	106.2	26.0	94.4	20.9	82.6	16.5	
31	118.0	118.0	29.5	106.2	24.1	94.4	19.4	82.6	15.3	
30	118.0	118.0	28.4	106.2	23.3	94.4	18.7	82.6	14.8	
29	118.0	118.0	27.4	106.2	22.4	94.4	18.1	82.6	14.3	
27	118.0	118.0	25.5	106.2	20.9	94.4	16.8	82.6	13.4	
25	118.0	118.0	23.8	106.2	19.5	94.4	15.7	82.6	12.5	
23	118.0	118.0	22.2	106.2	18.2	94.4	14.7	82.6	11.7	
21	118.0	118.0	21.7	106.2	17.8	94.4	14.4	82.6	11.5	
20	118.0	118.0	21.5	106.2	17.7	94.4	14.3	82.6	11.4	
19	118.0	118.0	21.3	106.2	17.5	94.4	14.2	82.6	11.3	
17	118.0	118.0	20.9	106.2	17.2	94.4	13.9	82.6	11.1	
15	118.0	118.0	20.6	106.2	17.0	94.4	13.7	82.6	11.0	

Outdoor Unit Dry-Bulb (°C)		Outdoor Unit 100 % Cooling Capacity (kW)	Compressor + Outdoor Fan Power consumption (kW)							
			60 %		50 %		40 %		30 %	
			TC (kW)	PI (kW)	TC (kW)	PI (kW)	TC (kW)	PI (kW)	TC (kW)	PI (kW)
40	109.8	65.9	14.8	54.9	11.4	43.9	9.03	32.9	7.70	
39	111.6	66.9	14.6	55.8	11.3	44.6	8.90	33.5	7.59	
37	114.9	68.9	14.2	57.5	10.9	46.0	8.63	34.5	7.36	
35	118.0	70.8	13.7	59.0	10.6	47.2	8.36	35.4	7.12	
33	118.0	70.8	12.8	59.0	9.93	47.2	7.93	35.4	6.84	
31	118.0	70.8	12.0	59.0	9.34	47.2	7.53	35.4	6.57	
30	118.0	70.8	11.6	59.0	9.07	47.2	7.34	35.4	6.44	
29	118.0	70.8	11.2	59.0	8.81	47.2	7.16	35.4	6.30	
27	118.0	70.8	10.5	59.0	8.31	47.2	6.81	35.4	6.04	
25	118.0	70.8	9.87	59.0	7.85	47.2	6.47	35.4	5.78	
23	118.0	70.8	9.28	59.0	7.41	47.2	6.15	35.4	5.53	
21	118.0	70.8	9.13	59.0	7.32	47.2	6.10	35.4	5.52	
20	118.0	70.8	9.06	59.0	7.28	47.2	6.08	35.4	5.51	
19	118.0	70.8	9.00	59.0	7.24	47.2	6.07	35.4	5.51	
17	118.0	70.8	8.89	59.0	7.17	47.2	6.04	35.4	5.51	
15	118.0	70.8	8.79	59.0	7.12	47.2	6.01	35.4	5.50	

TC : Total Capacity PI : Power Input
Indoor air temperature conditions : 27.0 °C dry-bulb / 19.0 °C wet bulb

Heating

Outdoor Unit Dry-Bulb (°C)		Outdoor Unit Wet-Bulb (°C)	Outdoor Unit 100 % Heating Capacity (kW)	Compressor + Outdoor Fan Power consumption (kW)							
				100 %		90 %		80 %		70 %	
				TC (kW)	PI (kW)	TC (kW)	PI (kW)	TC (kW)	PI (kW)	TC (kW)	PI (kW)
15.0	13.7	132.0	132.0	29.6	118.8	24.4	105.6	20.1	92.4	16.5	
13.0	11.8	132.0	132.0	30.7	118.8	25.3	105.6	20.7	92.4	16.9	
11.0	9.8	132.0	132.0	32.2	118.8	26.3	105.6	21.5	92.4	17.4	
9.0	7.9	132.0	132.0	33.7	118.8	27.5	105.6	22.3	92.4	18.0	
7.0	6.0	132.0	132.0	35.5	118.8	28.8	105.6	23.2	92.4	18.6	
5.0	4.1	127.5	127.5	34.9	114.8	28.4	102.0	22.9	89.3	18.3	
3.0	2.2	122.9	122.9	34.4	110.7	27.9	98.4	22.5	86.1	18.1	
0.0	-0.7	115.8	115.8	33.6	104.2	27.2	92.6	22.0	81.1	17.6	
-3.0	-3.7	108.2	108.2	32.7	97.4	26.6	86.6	21.4	75.7	17.2	
-5.0	-5.6	103.3	103.3	32.2	92.9	26.1	82.6	21.1	72.3	16.9	
-7.0	-7.6	98.0	98.0	31.6	88.2	25.7	78.4	20.7	68.6	16.6	
-10	-10.5	90.1	90.1	30.8	81.1	25.0	72.1	20.2	63.1	16.2	
-14.5	-15.0	77.6	77.6	29.5	69.8	24.0	62.1	19.3	54.3	15.5	

Outdoor Unit Dry-Bulb (°C)		Outdoor Unit Wet-Bulb (°C)	Outdoor Unit 100 % Heating Capacity (kW)	Compressor + Outdoor Fan Power consumption (kW)							
				60 %		50 %		40 %		30 %	
				TC (kW)	PI (kW)	TC (kW)	PI (kW)	TC (kW)	PI (kW)	TC (kW)	PI (kW)
15.0	13.7	132.0	79.2	13.6	66.0	11.2	52.8	9.37	39.6	7.93	
13.0	11.8	132.0	79.2	13.8	66.0	11.4	52.8	9.42	39.6	7.92	
11.0	9.8	132.0	79.2	14.2	66.0	11.5	52.8	9.49	39.6	7.92	
9.0	7.9	132.0	79.2	14.5	66.0	11.7	52.8	9.58	39.6	7.94	
7.0	6.0	132.0	79.2	14.9	66.0	12.0	52.8	9.69	39.6	7.96	
5.0	4.1	127.5	76.5	14.7	63.8	11.8	51.0	9.54	38.3	7.84	
3.0	2.2	122.9	73.8	14.5	61.5	11.6	49.2	9.39	36.9	7.72	
0.0	-0.7	115.8	69.5	14.1	57.9	11.3	46.3	9.17	34.7	7.53	
-3.0	-3.7	108.2	64.9	13.8	54.1	11.0	43.3	8.94	32.5	7.34	
-5.0	-5.6	103.3	62.0	13.5	51.6	10.9	41.3	8.79	31.0	7.22	
-7.0	-7.6	98.0	58.8	13.3	49.0	10.7	39.2	8.63	29.4	7.09	
-10	-10.5	90.1	54.1	12.9	45.1	10.4	36.1	8.41	27.0	6.91	
-14.5	-15.0	77.6	46.6	12.4	38.8	9.96	31.0	8.06	23.3	6.62	

TC : Total Capacity PI : Power Input
Indoor air temperature conditions : 20.0 °C dry-bulb



MMY-AP4414HT8P-E, AP4414T8P-E (44HP, 123.5 kW system)

Cooling

Outdoor Unit Dry-Bulb (°C)		Outdoor Unit 100 % Cooling Capacity (kW)	Compressor + Outdoor Fan Power consumption (kW)							
			100 %		90 %		80 %		70 %	
			TC (kW)	PI (kW)	TC (kW)	PI (kW)	TC (kW)	PI (kW)	TC (kW)	PI (kW)
40	114.9	114.9	39.3	103.4	32.2	91.9	25.8	80.4	20.2	
39	116.8	116.8	39.3	105.1	32.2	93.4	25.8	81.7	20.2	
37	120.3	120.3	38.1	108.2	31.2	96.2	25.0	84.2	19.6	
35	123.5	123.5	37.0	111.2	30.2	98.8	24.2	86.5	18.9	
33	123.5	123.5	34.1	111.2	27.9	98.8	22.4	86.5	17.6	
31	123.5	123.5	31.6	111.2	25.9	98.8	20.8	86.5	16.3	
30	123.5	123.5	30.5	111.2	25.0	98.8	20.0	86.5	15.8	
29	123.5	123.5	29.4	111.2	24.1	98.8	19.3	86.5	15.2	
27	123.5	123.5	27.4	111.2	22.4	98.8	18.0	86.5	14.2	
25	123.5	123.5	25.6	111.2	20.9	98.8	16.8	86.5	13.3	
23	123.5	123.5	23.9	111.2	19.6	98.8	15.7	86.5	12.5	
21	123.5	123.5	23.3	111.2	19.1	98.8	15.4	86.5	12.2	
20	123.5	123.5	23.1	111.2	18.9	98.8	15.3	86.5	12.1	
19	123.5	123.5	22.9	111.2	18.8	98.8	15.1	86.5	12.0	
17	123.5	123.5	22.5	111.2	18.4	98.8	14.9	86.5	11.8	
15	123.5	123.5	22.1	111.2	18.2	98.8	14.7	86.5	11.7	

Outdoor Unit Dry-Bulb (°C)		Outdoor Unit 100 % Cooling Capacity (kW)	Compressor + Outdoor Fan Power consumption (kW)							
			60 %		50 %		40 %		30 %	
			TC (kW)	PI (kW)	TC (kW)	PI (kW)	TC (kW)	PI (kW)	TC (kW)	PI (kW)
40	114.9	69.0	15.5	57.5	11.9	46.0	9.36	34.5	8.04	
39	116.8	70.1	15.5	58.4	11.9	46.7	9.36	35.0	8.04	
37	120.3	72.2	15.0	60.1	11.5	48.1	9.08	36.1	7.80	
35	123.5	74.1	14.6	61.8	11.2	49.4	8.79	37.1	7.55	
33	123.5	74.1	13.6	61.8	10.5	49.4	8.34	37.1	7.26	
31	123.5	74.1	12.7	61.8	9.85	49.4	7.92	37.1	6.98	
30	123.5	74.1	12.3	61.8	9.55	49.4	7.73	37.1	6.84	
29	123.5	74.1	11.9	61.8	9.28	49.4	7.53	37.1	6.71	
27	123.5	74.1	11.1	61.8	8.75	49.4	7.17	37.1	6.44	
25	123.5	74.1	10.4	61.8	8.26	49.4	6.81	37.1	6.17	
23	123.5	74.1	9.81	61.8	7.79	49.4	6.47	37.1	5.90	
21	123.5	74.1	9.65	61.8	7.70	49.4	6.43	37.1	5.89	
20	123.5	74.1	9.58	61.8	7.65	49.4	6.41	37.1	5.89	
19	123.5	74.1	9.51	61.8	7.61	49.4	6.39	37.1	5.89	
17	123.5	74.1	9.39	61.8	7.54	49.4	6.36	37.1	5.89	
15	123.5	74.1	9.29	61.8	7.48	49.4	6.33	37.1	5.88	

TC : Total Capacity PI : Power Input
Indoor air temperature conditions : 27.0 °C dry-bulb / 19.0 °C wet bulb

Heating

Outdoor Unit Dry-Bulb (°C) Wet-Bulb (°C)			Outdoor Unit 100 % Heating Capacity (kW)	Compressor + Outdoor Fan Power consumption (kW)							
				100 %		90 %		80 %		70 %	
				TC (kW)	PI (kW)	TC (kW)	PI (kW)	TC (kW)	PI (kW)	TC (kW)	PI (kW)
15.0	13.7	138.0	138.0	32.4	124.2	26.7	110.4	21.8	96.6	17.7	
13.0	11.8	138.0	138.0	33.7	124.2	27.7	110.4	22.5	96.6	18.2	
11.0	9.8	138.0	138.0	35.3	124.2	28.9	110.4	23.4	96.6	18.8	
9.0	7.9	138.0	138.0	36.9	124.2	30.1	110.4	24.3	96.6	19.5	
7.0	6.0	138.0	138.0	38.9	124.2	31.6	110.4	25.4	96.6	20.2	
5.0	4.1	133.3	133.3	38.3	120.0	31.1	106.6	25.0	93.3	19.9	
3.0	2.2	128.5	128.5	37.7	115.7	30.6	102.8	24.6	90.0	19.6	
0.0	-0.7	121.1	121.1	36.8	109.0	29.9	96.9	24.0	84.7	19.1	
-3.0	-3.7	113.1	113.1	35.8	101.8	29.1	90.5	23.4	79.2	18.6	
-5.0	-5.6	108.0	108.0	35.2	97.2	28.7	86.4	23.0	75.6	18.3	
-7.0	-7.6	102.4	102.4	34.6	92.2	28.1	82.0	22.6	71.7	18.0	
-10	-10.5	94.2	94.2	33.7	84.8	27.4	75.4	22.0	66.0	17.5	
-14.5	-15.0	81.1	81.1	32.3	73.0	26.3	64.9	21.1	56.8	16.8	

Outdoor Unit Dry-Bulb (°C) Wet-Bulb (°C)			Outdoor Unit 100 % Heating Capacity (kW)	Compressor + Outdoor Fan Power consumption (kW)							
				60 %		50 %		40 %		30 %	
				TC (kW)	PI (kW)	TC (kW)	PI (kW)	TC (kW)	PI (kW)	TC (kW)	PI (kW)
15.0	13.7	138.0	82.8	14.4	69.0	11.9	55.2	10.0	41.4	8.89	
13.0	11.8	138.0	82.8	14.7	69.0	12.0	55.2	10.1	41.4	8.84	
11.0	9.8	138.0	82.8	15.1	69.0	12.2	55.2	10.1	41.4	8.79	
9.0	7.9	138.0	82.8	15.5	69.0	12.4	55.2	10.2	41.4	8.75	
7.0	6.0	138.0	82.8	16.0	69.0	12.7	55.2	10.3	41.4	8.73	
5.0	4.1	133.3	80.0	15.7	66.7	12.5	53.3	10.13	40.0	8.60	
3.0	2.2	128.5	77.1	15.5	64.3	12.3	51.4	9.97	38.6	8.46	
0.0	-0.7	121.1	72.6	15.1	60.5	12.0	48.4	9.74	36.3	8.26	
-3.0	-3.7	113.1	67.9	14.7	56.6	11.7	45.2	9.49	33.9	8.05	
-5.0	-5.6	108.0	64.8	14.5	54.0	11.5	43.2	9.33	32.4	7.92	
-7.0	-7.6	102.4	61.5	14.2	51.2	11.3	41.0	9.17	30.7	7.78	
-10	-10.5	94.2	56.5	13.9	47.1	11.0	37.7	8.93	28.3	7.58	
-14.5	-15.0	81.1	48.7	13.3	40.6	10.6	32.4	8.56	24.3	7.26	

TC : Total Capacity PI : Power Input
Indoor air temperature conditions : 20.0 °C dry-bulb



MMY-AP4614HT8P-E, AP4614T8P-E (46HP, 130 kW system)

Cooling

Outdoor Unit Dry-Bulb (°C)		Outdoor Unit 100 % Cooling Capacity (kW)	Compressor + Outdoor Fan Power consumption (kW)							
			100 %		90 %		80 %		70 %	
			TC (kW)	PI (kW)	TC (kW)	PI (kW)	TC (kW)	PI (kW)	TC (kW)	PI (kW)
40	121.0	121.0	42.0	108.9	34.4	96.8	27.5	84.7	21.5	
39	122.9	122.9	41.4	110.6	33.9	98.3	27.1	86.0	21.2	
37	126.6	126.6	40.1	113.9	32.9	101.3	26.3	88.6	20.5	
35	130.0	130.0	38.9	117.0	31.8	104.0	25.5	91.0	19.9	
33	130.0	130.0	35.9	117.0	29.4	104.0	23.6	91.0	18.4	
31	130.0	130.0	33.3	117.0	27.3	104.0	21.9	91.0	17.1	
30	130.0	130.0	32.1	117.0	26.3	104.0	21.1	91.0	16.5	
29	130.0	130.0	31.0	117.0	25.4	104.0	20.3	91.0	16.0	
27	130.0	130.0	28.9	117.0	23.6	104.0	19.0	91.0	14.9	
25	130.0	130.0	26.9	117.0	22.0	104.0	17.7	91.0	13.9	
23	130.0	130.0	25.1	117.0	20.6	104.0	16.5	91.0	13.1	
21	130.0	130.0	24.6	117.0	20.1	104.0	16.2	91.0	12.8	
20	130.0	130.0	24.3	117.0	19.9	104.0	16.0	91.0	12.7	
19	130.0	130.0	24.1	117.0	19.7	104.0	15.9	91.0	12.6	
17	130.0	130.0	23.7	117.0	19.4	104.0	15.6	91.0	12.4	
15	130.0	130.0	23.3	117.0	19.1	104.0	15.4	91.0	12.2	

Outdoor Unit Dry-Bulb (°C)		Outdoor Unit 100 % Cooling Capacity (kW)	Compressor + Outdoor Fan Power consumption (kW)							
			60 %		50 %		40 %		30 %	
			TC (kW)	PI (kW)	TC (kW)	PI (kW)	TC (kW)	PI (kW)	TC (kW)	PI (kW)
40	121.0	72.6	16.5	60.5	12.5	48.4	9.84	36.3	8.51	
39	122.9	73.8	16.2	61.5	12.3	49.2	9.69	36.9	8.39	
37	126.6	76.0	15.7	63.3	12.0	50.6	9.40	38.0	8.13	
35	130.0	78.0	15.2	65.0	11.6	52.0	9.10	39.0	7.88	
33	130.0	78.0	14.2	65.0	10.9	52.0	8.64	39.0	7.58	
31	130.0	78.0	13.2	65.0	10.2	52.0	8.21	39.0	7.30	
30	130.0	78.0	12.8	65.0	9.91	52.0	8.00	39.0	7.16	
29	130.0	78.0	12.4	65.0	9.62	52.0	7.81	39.0	7.02	
27	130.0	78.0	11.6	65.0	9.07	52.0	7.43	39.0	6.74	
25	130.0	78.0	10.9	65.0	8.56	52.0	7.06	39.0	6.46	
23	130.0	78.0	10.2	65.0	8.08	52.0	6.71	39.0	6.19	
21	130.0	78.0	10.0	65.0	7.97	52.0	6.67	39.0	6.18	
20	130.0	78.0	9.96	65.0	7.93	52.0	6.65	39.0	6.18	
19	130.0	78.0	9.89	65.0	7.89	52.0	6.63	39.0	6.18	
17	130.0	78.0	9.76	65.0	7.81	52.0	6.60	39.0	6.18	
15	130.0	78.0	9.65	65.0	7.75	52.0	6.57	39.0	6.18	

TC : Total Capacity PI : Power Input
Indoor air temperature conditions : 27.0 °C dry-bulb / 19.0 °C wet bulb

Heating

Outdoor Unit Dry-Bulb (°C) Wet-Bulb (°C)			Outdoor Unit 100 % Heating Capacity (kW)	Compressor + Outdoor Fan Power consumption (kW)							
				100 %		90 %		80 %		70 %	
				TC (kW)	PI (kW)	TC (kW)	PI (kW)	TC (kW)	PI (kW)	TC (kW)	PI (kW)
15.0	13.7	145.0	145.0	33.0	130.5	27.2	116.0	22.3	101.5	18.2	
13.0	11.8	145.0	145.0	34.3	130.5	28.2	116.0	23.0	101.5	18.7	
11.0	9.8	145.0	145.0	35.9	130.5	29.4	116.0	23.9	101.5	19.3	
9.0	7.9	145.0	145.0	37.6	130.5	30.7	116.0	24.8	101.5	19.9	
7.0	6.0	145.0	145.0	39.6	130.5	32.2	116.0	25.9	101.5	20.7	
5.0	4.1	140.1	140.1	39.0	126.1	31.7	112.1	25.5	98.1	20.3	
3.0	2.2	135.1	135.1	38.4	121.5	31.2	108.0	25.1	94.5	20.0	
0.0	-0.7	127.2	127.2	37.5	114.5	30.4	101.8	24.5	89.0	19.5	
-3.0	-3.7	118.9	118.9	36.5	107.0	29.7	95.1	23.9	83.2	19.1	
-5.0	-5.6	113.4	113.4	35.9	102.1	29.2	90.8	23.5	79.4	18.7	
-7.0	-7.6	107.6	107.6	35.3	96.9	28.7	86.1	23.1	75.3	18.4	
-10	-10.5	99.0	99.0	34.4	89.1	27.9	79.2	22.5	69.3	17.9	
-14.5	-15.0	85.2	85.2	32.9	76.7	26.8	68.2	21.5	59.7	17.2	

Outdoor Unit Dry-Bulb (°C) Wet-Bulb (°C)			Outdoor Unit 100 % Heating Capacity (kW)	Compressor + Outdoor Fan Power consumption (kW)							
				60 %		50 %		40 %		30 %	
				TC (kW)	PI (kW)	TC (kW)	PI (kW)	TC (kW)	PI (kW)	TC (kW)	PI (kW)
15.0	13.7	145.0	87.0	14.9	72.5	12.3	58.0	10.3	43.5	8.99	
13.0	11.8	145.0	87.0	15.2	72.5	12.4	58.0	10.4	43.5	8.95	
11.0	9.8	145.0	87.0	15.5	72.5	12.6	58.0	10.4	43.5	8.92	
9.0	7.9	145.0	87.0	16.0	72.5	12.8	58.0	10.5	43.5	8.91	
7.0	6.0	145.0	87.0	16.4	72.5	13.1	58.0	10.6	43.5	8.90	
5.0	4.1	140.1	84.0	16.2	70.0	12.9	56.0	10.5	42.0	8.77	
3.0	2.2	135.1	81.0	15.9	67.5	12.7	54.0	10.3	40.5	8.63	
0.0	-0.7	127.2	76.3	15.5	63.6	12.4	50.9	10.1	38.2	8.42	
-3.0	-3.7	118.9	71.3	15.1	59.4	12.1	47.5	9.80	35.7	8.21	
-5.0	-5.6	113.4	68.1	14.9	56.7	11.9	45.4	9.64	34.0	8.07	
-7.0	-7.6	107.6	64.6	14.6	53.8	11.7	43.1	9.47	32.3	7.93	
-10	-10.5	99.0	59.4	14.3	49.5	11.4	39.6	9.22	29.7	7.73	
-14.5	-15.0	85.2	51.1	13.7	42.6	10.9	34.1	8.84	25.6	7.41	

TC : Total Capacity PI : Power Input
Indoor air temperature conditions : 20.0 °C dry-bulb



MMY-AP4814HT8P-E, AP4814T8P-E (48HP, 135 kW system)

Cooling

Outdoor Unit Dry-Bulb (°C)		Outdoor Unit 100 % Cooling Capacity (kW)	Compressor + Outdoor Fan Power consumption (kW)							
			100 %		90 %		80 %		70 %	
			TC (kW)	PI (kW)	TC (kW)	PI (kW)	TC (kW)	PI (kW)	TC (kW)	PI (kW)
40	125.6	125.6	44.4	113.1	36.4	100.5	29.1	87.9	22.7	
39	127.6	127.6	43.7	114.9	35.8	102.1	28.6	89.4	22.4	
37	131.5	131.5	42.4	118.3	34.7	105.2	27.8	92.0	21.7	
35	135.0	135.0	41.1	121.5	33.6	108.0	26.9	94.5	21.0	
33	135.0	135.0	38.0	121.5	31.1	108.0	24.9	94.5	19.5	
31	135.0	135.0	35.2	121.5	28.8	108.0	23.1	94.5	18.1	
30	135.0	135.0	34.0	121.5	27.8	108.0	22.3	94.5	17.5	
29	135.0	135.0	32.7	121.5	26.8	108.0	21.5	94.5	16.9	
27	135.0	135.0	30.5	121.5	25.0	108.0	20.0	94.5	15.7	
25	135.0	135.0	28.5	121.5	23.3	108.0	18.7	94.5	14.7	
23	135.0	135.0	26.6	121.5	21.8	108.0	17.5	94.5	13.8	
21	135.0	135.0	26.0	121.5	21.3	108.0	17.1	94.5	13.5	
20	135.0	135.0	25.7	121.5	21.1	108.0	16.9	94.5	13.4	
19	135.0	135.0	25.5	121.5	20.9	108.0	16.8	94.5	13.3	
17	135.0	135.0	25.0	121.5	20.5	108.0	16.5	94.5	13.1	
15	135.0	135.0	24.6	121.5	20.2	108.0	16.3	94.5	12.9	

Outdoor Unit Dry-Bulb (°C)		Outdoor Unit 100 % Cooling Capacity (kW)	Compressor + Outdoor Fan Power consumption (kW)							
			60 %		50 %		40 %		30 %	
			TC (kW)	PI (kW)	TC (kW)	PI (kW)	TC (kW)	PI (kW)	TC (kW)	PI (kW)
40	125.6	75.4	17.4	62.8	13.2	50.3	10.4	37.7	9.06	
39	127.6	76.6	17.1	63.8	13.0	51.1	10.3	38.3	8.92	
37	131.5	78.9	16.6	65.7	12.6	52.6	9.95	39.4	8.65	
35	135.0	81.0	16.1	67.5	12.2	54.0	9.63	40.5	8.38	
33	135.0	81.0	15.0	67.5	11.5	54.0	9.14	40.5	8.07	
31	135.0	81.0	14.0	67.5	10.8	54.0	8.69	40.5	7.77	
30	135.0	81.0	13.5	67.5	10.5	54.0	8.48	40.5	7.62	
29	135.0	81.0	13.1	67.5	10.2	54.0	8.27	40.5	7.47	
27	135.0	81.0	12.2	67.5	9.59	54.0	7.87	40.5	7.18	
25	135.0	81.0	11.5	67.5	9.05	54.0	7.49	40.5	6.89	
23	135.0	81.0	10.8	67.5	8.54	54.0	7.12	40.5	6.59	
21	135.0	81.0	10.6	67.5	8.43	54.0	7.07	40.5	6.59	
20	135.0	81.0	10.5	67.5	8.38	54.0	7.05	40.5	6.59	
19	135.0	81.0	10.4	67.5	8.34	54.0	7.03	40.5	6.59	
17	135.0	81.0	10.3	67.5	8.26	54.0	7.00	40.5	6.59	
15	135.0	81.0	10.2	67.5	8.20	54.0	6.97	40.5	6.59	

TC : Total Capacity PI : Power Input
Indoor air temperature conditions : 27.0 °C dry-bulb / 19.0 °C wet bulb

Heating

Outdoor Unit Dry-Bulb (°C)		Outdoor Unit Wet-Bulb (°C)	Outdoor Unit 100 % Heating Capacity (kW)	Compressor + Outdoor Fan Power consumption (kW)							
				100 %		90 %		80 %		70 %	
				TC (kW)	PI (kW)	TC (kW)	PI (kW)	TC (kW)	PI (kW)	TC (kW)	PI (kW)
15.0	13.7	150.0	150.0	35.6	135.0	29.2	120.0	23.8	105.0	19.2	
13.0	11.8	150.0	150.0	37.0	135.0	30.3	120.0	24.6	105.0	19.7	
11.0	9.8	150.0	150.0	38.7	135.0	31.6	120.0	25.5	105.0	20.4	
9.0	7.9	150.0	150.0	40.5	135.0	33.0	120.0	26.6	105.0	21.1	
7.0	6.0	150.0	150.0	42.6	135.0	34.6	120.0	27.8	105.0	22.0	
5.0	4.1	144.9	144.9	41.9	130.4	34.1	115.9	27.4	101.4	21.7	
3.0	2.2	139.7	139.7	41.3	125.7	33.6	111.8	26.9	97.8	21.3	
0.0	-0.7	131.6	131.6	40.3	118.4	32.8	105.3	26.3	92.1	20.8	
-3.0	-3.7	123.0	123.0	39.3	110.7	32.0	98.4	25.6	86.1	20.3	
-5.0	-5.6	117.4	117.4	38.6	105.6	31.4	93.9	25.2	82.1	19.9	
-7.0	-7.6	111.3	111.3	38.0	100.2	30.9	89.1	24.8	77.9	19.6	
-10	-10.5	102.4	102.4	37.0	92.2	30.1	82.0	24.1	71.7	19.1	
-14.5	-15.0	88.2	88.2	35.4	79.3	28.8	70.5	23.1	61.7	18.3	

Outdoor Unit Dry-Bulb (°C)		Outdoor Unit Wet-Bulb (°C)	Outdoor Unit 100 % Heating Capacity (kW)	Compressor + Outdoor Fan Power consumption (kW)							
				60 %		50 %		40 %		30 %	
				TC (kW)	PI (kW)	TC (kW)	PI (kW)	TC (kW)	PI (kW)	TC (kW)	PI (kW)
15.0	13.7	150.0	90.0	15.5	75.0	12.8	60.0	10.9	45.0	9.90	
13.0	11.8	150.0	90.0	15.9	75.0	12.9	60.0	10.9	45.0	9.80	
11.0	9.8	150.0	90.0	16.3	75.0	13.1	60.0	10.9	45.0	9.71	
9.0	7.9	150.0	90.0	16.7	75.0	13.3	60.0	11.0	45.0	9.64	
7.0	6.0	150.0	90.0	17.3	75.0	13.6	60.0	11.1	45.0	9.58	
5.0	4.1	144.9	86.9	17.0	72.5	13.4	58.0	10.9	43.5	9.44	
3.0	2.2	139.7	83.8	16.7	69.9	13.2	55.9	10.7	41.9	9.29	
0.0	-0.7	131.6	79.0	16.3	65.8	12.9	52.6	10.5	39.5	9.07	
-3.0	-3.7	123.0	73.8	15.9	61.5	12.6	49.2	10.2	36.9	8.84	
-5.0	-5.6	117.4	70.4	15.7	58.7	12.4	46.9	10.0	35.2	8.70	
-7.0	-7.6	111.3	66.8	15.4	55.7	12.1	44.5	9.87	33.4	8.54	
-10	-10.5	102.4	61.5	15.0	51.2	11.8	41.0	9.61	30.7	8.32	
-14.5	-15.0	88.2	52.9	14.4	44.1	11.3	35.3	9.21	26.4	7.97	

TC : Total Capacity PI : Power Input
Indoor air temperature conditions : 20.0 °C dry-bulb



• High efficiency model

MMY-AP1624HT8P-E, AP1624T8P-E (16HP, 45 kW system)

Cooling

Outdoor Unit Dry-Bulb (°C)		Outdoor Unit 100 % Cooling Capacity (kW)	Compressor + Outdoor Fan Power consumption (kW)							
			100 %		90 %		80 %		70 %	
			TC (kW)	PI (kW)	TC (kW)	PI (kW)	TC (kW)	PI (kW)	TC (kW)	PI (kW)
40		41.9	11.8	37.7	9.67	33.5	7.84	29.3	6.27	
39		42.5	11.6	38.3	9.53	34.0	7.72	29.8	6.17	
37		43.8	11.2	39.4	9.24	35.1	7.49	30.7	5.99	
35		45.0	10.9	40.5	8.95	36.0	7.25	31.5	5.80	
33		45.0	10.1	40.5	8.29	36.0	6.73	31.5	5.40	
31		45.0	9.34	40.5	7.70	36.0	6.27	31.5	5.04	
30		45.0	9.00	40.5	7.43	36.0	6.1	31.5	4.87	
29		45.0	8.69	40.5	7.17	36.0	5.85	31.5	4.72	
27		45.0	8.10	40.5	6.69	36.0	5.47	31.5	4.42	
25		45.0	7.56	40.5	6.26	36.0	5.12	31.5	4.15	
23		45.0	7.07	40.5	5.85	36.0	4.80	31.5	3.89	
21		45.0	6.92	40.5	5.74	36.0	4.71	31.5	3.83	
20		45.0	6.85	40.5	5.68	36.0	4.66	31.5	3.80	
19		45.0	6.79	40.5	5.63	36.0	4.63	31.5	3.77	
17		45.0	6.68	40.5	5.54	36.0	4.56	31.5	3.72	
15		45.0	6.58	40.5	5.47	36.0	4.50	31.5	3.68	

Outdoor Unit Dry-Bulb (°C)		Outdoor Unit 100 % Cooling Capacity (kW)	Compressor + Outdoor Fan Power consumption (kW)							
			60 %		50 %		40 %		30 %	
			TC (kW)	PI (kW)	TC (kW)	PI (kW)	TC (kW)	PI (kW)	TC (kW)	PI (kW)
40		41.9	4.96	20.9	3.91	16.8	3.12	12.6	2.59	
39		42.5	4.88	21.3	3.85	17.0	3.07	12.8	2.55	
37		43.8	4.73	21.9	3.73	17.5	2.98	13.1	2.48	
35		45.0	4.59	22.5	3.61	18.0	2.89	13.5	2.40	
33		45.0	4.29	22.5	3.40	18.0	2.74	13.5	2.30	
31		45.0	4.02	22.5	3.21	18.0	2.60	13.5	2.20	
30		45.0	3.90	22.5	3.11	18.0	2.53	13.5	2.15	
29		45.0	3.78	22.5	3.03	18.0	2.47	13.5	2.10	
27		45.0	3.55	22.5	2.86	18.0	2.34	13.5	2.01	
25		45.0	3.34	22.5	2.70	18.0	2.23	13.5	1.92	
23		45.0	3.15	22.5	2.55	18.0	2.11	13.5	1.83	
21		45.0	3.10	22.5	2.52	18.0	2.10	13.5	1.82	
20		45.0	3.08	22.5	2.51	18.0	2.09	13.5	1.82	
19		45.0	3.06	22.5	2.50	18.0	2.08	13.5	1.81	
17		45.0	3.02	22.5	2.47	18.0	2.07	13.5	1.81	
15		45.0	2.99	22.5	2.46	18.0	2.06	13.5	1.80	

TC : Total Capacity PI : Power Input
Indoor air temperature conditions : 27.0 °C dry-bulb / 19.0 °C wet bulb

Heating

Outdoor Unit Dry-Bulb (°C) Wet-Bulb (°C) Heating Capacity (kW)			Compressor + Outdoor Fan Power consumption (kW)							
			100 %		90 %		80 %		70 %	
			TC (kW)	PI (kW)	TC (kW)	PI (kW)	TC (kW)	PI (kW)	TC (kW)	PI (kW)
15.0	13.7	50.0	9.20	45.0	7.64	40.0	6.35	35.0	5.29	
13.0	11.8	50.0	9.57	45.0	7.90	40.0	6.53	35.0	5.41	
11.0	9.8	50.0	10.0	45.0	8.21	40.0	6.74	35.0	5.55	
9.0	7.9	50.0	10.5	45.0	8.56	40.0	6.98	35.0	5.71	
7.0	6.0	50.0	11.1	45.0	8.96	40.0	7.26	35.0	5.89	
5.0	4.1	48.3	10.9	43.5	8.82	38.6	7.15	33.8	5.80	
3.0	2.2	46.6	10.7	41.9	8.69	37.3	7.04	32.6	5.71	
0.0	-0.7	43.9	10.5	39.5	8.48	35.1	6.87	30.7	5.58	
-3.0	-3.7	41.0	10.2	36.9	8.26	32.8	6.70	28.7	5.43	
-5.0	-5.6	39.1	10.0	35.2	8.13	31.3	6.58	27.4	5.34	
-7.0	-7.6	37.1	9.85	33.4	7.98	29.7	6.47	26.0	5.25	
-10	-10.5	34.1	9.60	30.7	7.78	27.3	6.30	23.9	5.11	
-14.5	-15.0	29.4	9.20	26.4	7.45	23.5	6.04	20.6	4.90	

Outdoor Unit Dry-Bulb (°C) Wet-Bulb (°C) Heating Capacity (kW)			Compressor + Outdoor Fan Power consumption (kW)							
			60 %		50 %		40 %		30 %	
			TC (kW)	PI (kW)	TC (kW)	PI (kW)	TC (kW)	PI (kW)	TC (kW)	PI (kW)
15.0	13.7	50.0	4.41	25.0	3.67	20.0	3.01	15.0	2.39	
13.0	11.8	50.0	4.49	25.0	3.71	20.0	3.04	15.0	2.41	
11.0	9.8	50.0	4.58	25.0	3.77	20.0	3.07	15.0	2.43	
9.0	7.9	50.0	4.68	25.0	3.83	20.0	3.11	15.0	2.45	
7.0	6.0	50.0	4.79	25.0	3.90	20.0	3.15	15.0	2.48	
5.0	4.1	48.3	4.72	24.2	3.84	19.3	3.10	14.5	2.44	
3.0	2.2	46.6	4.65	23.3	3.78	18.6	3.06	14.0	2.41	
0.0	-0.7	43.9	4.54	21.9	3.69	17.5	2.98	13.2	2.35	
-3.0	-3.7	41.0	4.42	20.5	3.60	16.4	2.91	12.3	2.29	
-5.0	-5.6	39.1	4.35	19.6	3.54	15.6	2.86	11.7	2.25	
-7.0	-7.6	37.1	4.27	18.6	3.48	14.8	2.81	11.1	2.21	
-10	-10.5	34.1	4.16	17.1	3.39	13.7	2.74	10.2	2.15	
-14.5	-15.0	29.4	3.99	14.7	3.25	11.8	2.62	8.82	2.06	

TC : Total Capacity PI : Power Input
Indoor air temperature conditions : 20.0 °C dry-bulb



MMY-AP2424HT8P-E, AP2424T8P-E (24HP, 68 kW system)

Cooling

Outdoor Unit Dry-Bulb (°C)		Outdoor Unit 100 % Cooling Capacity (kW)	Compressor + Outdoor Fan Power consumption (kW)							
			100 %		90 %		80 %		70 %	
			TC (kW)	PI (kW)	TC (kW)	PI (kW)	TC (kW)	PI (kW)	TC (kW)	PI (kW)
40	63.3	63.3	17.9	57.0	14.7	50.6	11.9	44.3	9.54	
39	64.3	64.3	17.6	57.9	14.5	51.4	11.8	45.0	9.40	
37	66.2	66.2	17.1	59.6	14.1	53.0	11.4	46.4	9.11	
35	68.0	68.0	16.6	61.2	13.6	54.4	11.0	47.6	8.83	
33	68.0	68.0	15.3	61.2	12.6	54.4	10.2	47.6	8.22	
31	68.0	68.0	14.2	61.2	11.7	54.4	9.54	47.6	7.67	
30	68.0	68.0	13.7	61.2	11.3	54.4	9.22	47.6	7.42	
29	68.0	68.0	13.2	61.2	10.9	54.4	8.90	47.6	7.18	
27	68.0	68.0	12.3	61.2	10.2	54.4	8.33	47.6	6.73	
25	68.0	68.0	11.5	61.2	9.53	54.4	7.80	47.6	6.32	
23	68.0	68.0	10.8	61.2	8.91	54.4	7.30	47.6	5.93	
21	68.0	68.0	10.5	61.2	8.73	54.4	7.16	47.6	5.83	
20	68.0	68.0	10.4	61.2	8.65	54.4	7.10	47.6	5.78	
19	68.0	68.0	10.3	61.2	8.58	54.4	7.04	47.6	5.74	
17	68.0	68.0	10.2	61.2	8.44	54.4	6.94	47.6	5.66	
15	68.0	68.0	10.0	61.2	8.33	54.4	6.85	47.6	5.60	

Outdoor Unit Dry-Bulb (°C)		Outdoor Unit 100 % Cooling Capacity (kW)	Compressor + Outdoor Fan Power consumption (kW)							
			60 %		50 %		40 %		30 %	
			TC (kW)	PI (kW)	TC (kW)	PI (kW)	TC (kW)	PI (kW)	TC (kW)	PI (kW)
40	63.3	38.0	7.54	31.6	5.95	25.3	4.75	19.0	3.95	
39	64.3	38.6	7.43	32.1	5.86	25.7	4.68	19.3	3.89	
37	66.2	39.7	7.21	33.1	5.68	26.5	4.54	19.9	3.77	
35	68.0	40.8	6.98	34.0	5.50	27.2	4.39	20.4	3.65	
33	68.0	40.8	6.53	34.0	5.18	27.2	4.17	20.4	3.49	
31	68.0	40.8	6.12	34.0	4.88	27.2	3.96	20.4	3.34	
30	68.0	40.8	5.93	34.0	4.74	27.2	3.85	20.4	3.27	
29	68.0	40.8	5.75	34.0	4.61	27.2	3.76	20.4	3.20	
27	68.0	40.8	5.41	34.0	4.35	27.2	3.57	20.4	3.06	
25	68.0	40.8	5.09	34.0	4.11	27.2	3.39	20.4	2.92	
23	68.0	40.8	4.79	34.0	3.89	27.2	3.22	20.4	2.78	
21	68.0	40.8	4.72	34.0	3.84	27.2	3.19	20.4	2.77	
20	68.0	40.8	4.69	34.0	3.82	27.2	3.18	20.4	2.77	
19	68.0	40.8	4.66	34.0	3.80	27.2	3.17	20.4	2.76	
17	68.0	40.8	4.60	34.0	3.77	27.2	3.15	20.4	2.75	
15	68.0	40.8	4.56	34.0	3.74	27.2	3.13	20.4	2.75	

TC : Total Capacity PI : Power Input
Indoor air temperature conditions : 27.0 °C dry-bulb / 19.0 °C wet bulb

Heating

Outdoor Unit Dry-Bulb (°C) Wet-Bulb (°C) Heating Capacity (kW)			Compressor + Outdoor Fan Power consumption (kW)							
			100 %		90 %		80 %		70 %	
			TC (kW)	PI (kW)	TC (kW)	PI (kW)	TC (kW)	PI (kW)	TC (kW)	PI (kW)
15.0	13.7	76.5	76.5	14.3	68.9	11.9	61.2	9.87	53.6	8.22
13.0	11.8	76.5	76.5	14.9	68.9	12.3	61.2	10.1	53.6	8.40
11.0	9.8	76.5	76.5	15.5	68.9	12.8	61.2	10.5	53.6	8.62
9.0	7.9	76.5	76.5	16.3	68.9	13.3	61.2	10.8	53.6	8.87
7.0	6.0	76.5	76.5	17.2	68.9	13.9	61.2	11.3	53.6	9.15
5.0	4.1	73.9	73.9	16.9	66.5	13.7	59.1	11.1	51.7	9.01
3.0	2.2	71.3	71.3	16.7	64.1	13.5	57.0	10.9	49.9	8.87
0.0	-0.7	67.1	67.1	16.3	60.4	13.2	53.7	10.7	47.0	8.66
-3.0	-3.7	62.7	62.7	15.8	56.4	12.8	50.2	10.4	43.9	8.44
-5.0	-5.6	59.8	59.8	15.6	53.9	12.6	47.9	10.2	41.9	8.30
-7.0	-7.6	56.8	56.8	15.3	51.1	12.4	45.4	10.0	39.8	8.16
-10	-10.5	52.2	52.2	14.9	47.0	12.1	41.8	9.79	36.6	7.94
-14.5	-15.0	45.0	45.0	14.3	40.5	11.6	36.0	9.38	31.5	7.61

Outdoor Unit Dry-Bulb (°C) Wet-Bulb (°C) Heating Capacity (kW)			Compressor + Outdoor Fan Power consumption (kW)							
			60 %		50 %		40 %		30 %	
			TC (kW)	PI (kW)	TC (kW)	PI (kW)	TC (kW)	PI (kW)	TC (kW)	PI (kW)
15.0	13.7	76.5	45.9	6.85	38.3	5.70	30.6	4.68	23.0	3.72
13.0	11.8	76.5	45.9	6.97	38.3	5.77	30.6	4.72	23.0	3.74
11.0	9.8	76.5	45.9	7.11	38.3	5.85	30.6	4.77	23.0	3.78
9.0	7.9	76.5	45.9	7.27	38.3	5.95	30.6	4.83	23.0	3.81
7.0	6.0	76.5	45.9	7.45	38.3	6.06	30.6	4.90	23.0	3.85
5.0	4.1	73.9	44.3	7.33	37.0	5.97	29.6	4.82	22.2	3.79
3.0	2.2	71.3	42.8	7.22	35.6	5.88	28.5	4.75	21.4	3.74
0.0	-0.7	67.1	40.3	7.05	33.6	5.74	26.8	4.63	20.1	3.65
-3.0	-3.7	62.7	37.6	6.87	31.4	5.59	25.1	4.52	18.8	3.55
-5.0	-5.6	59.8	35.9	6.75	29.9	5.50	23.9	4.44	18.0	3.50
-7.0	-7.6	56.8	34.1	6.64	28.4	5.40	22.7	4.36	17.0	3.43
-10	-10.5	52.2	31.3	6.46	26.1	5.26	20.9	4.25	15.7	3.34
-14.5	-15.0	45.0	27.0	6.19	22.5	5.04	18.0	4.07	13.5	3.21

TC : Total Capacity PI : Power Input
Indoor air temperature conditions : 20.0 °C dry-bulb



MMY-AP2624HT8P-E, AP2624T8P-E (26HP, 73 kW system)

Cooling

Outdoor Unit Dry-Bulb (°C)		Outdoor Unit 100 % Cooling Capacity (kW)	Compressor + Outdoor Fan Power consumption (kW)							
			100 %		90 %		80 %		70 %	
			TC (kW)	PI (kW)	TC (kW)	PI (kW)	TC (kW)	PI (kW)	TC (kW)	PI (kW)
40	67.9	67.9	19.8	61.1	16.3	54.3	13.2	47.6	10.5	
39	69.0	69.0	19.5	62.1	16.0	55.2	13.0	48.3	10.4	
37	71.1	71.1	18.9	64.0	15.5	56.9	12.6	49.8	10.1	
35	73.0	73.0	18.3	65.7	15.0	58.4	12.2	51.1	9.75	
33	73.0	73.0	16.9	65.7	13.9	58.4	11.3	51.1	9.08	
31	73.0	73.0	15.7	65.7	12.9	58.4	10.54	51.1	8.47	
30	73.0	73.0	15.1	65.7	12.5	58.4	10.2	51.1	8.20	
29	73.0	73.0	14.6	65.7	12.1	58.4	9.83	51.1	7.93	
27	73.0	73.0	13.6	65.7	11.3	58.4	9.20	51.1	7.43	
25	73.0	73.0	12.7	65.7	10.5	58.4	8.61	51.1	6.97	
23	73.0	73.0	11.9	65.7	9.84	58.4	8.07	51.1	6.55	
21	73.0	73.0	11.6	65.7	9.64	58.4	7.91	51.1	6.43	
20	73.0	73.0	11.5	65.7	9.55	58.4	7.84	51.1	6.38	
19	73.0	73.0	11.4	65.7	9.47	58.4	7.78	51.1	6.34	
17	73.0	73.0	11.2	65.7	9.32	58.4	7.67	51.1	6.25	
15	73.0	73.0	11.1	65.7	9.20	58.4	7.57	51.1	6.18	

Outdoor Unit Dry-Bulb (°C)		Outdoor Unit 100 % Cooling Capacity (kW)	Compressor + Outdoor Fan Power consumption (kW)							
			60 %		50 %		40 %		30 %	
			TC (kW)	PI (kW)	TC (kW)	PI (kW)	TC (kW)	PI (kW)	TC (kW)	PI (kW)
40	67.9	40.8	8.33	34.0	6.57	27.2	5.24	20.4	4.36	
39	69.0	41.4	8.21	34.5	6.47	27.6	5.17	20.7	4.29	
37	71.1	42.7	7.96	35.5	6.28	28.4	5.01	21.3	4.16	
35	73.0	43.8	7.71	36.5	6.08	29.2	4.85	21.9	4.03	
33	73.0	43.8	7.21	36.5	5.72	29.2	4.60	21.9	3.86	
31	73.0	43.8	6.76	36.5	5.39	29.2	4.37	21.9	3.69	
30	73.0	43.8	6.55	36.5	5.24	29.2	4.26	21.9	3.61	
29	73.0	43.8	6.35	36.5	5.09	29.2	4.15	21.9	3.53	
27	73.0	43.8	5.97	36.5	4.81	29.2	3.94	21.9	3.38	
25	73.0	43.8	5.62	36.5	4.54	29.2	3.74	21.9	3.22	
23	73.0	43.8	5.29	36.5	4.29	29.2	3.55	21.9	3.07	
21	73.0	43.8	5.21	36.5	4.24	29.2	3.52	21.9	3.06	
20	73.0	43.8	5.17	36.5	4.22	29.2	3.51	21.9	3.06	
19	73.0	43.8	5.14	36.5	4.20	29.2	3.50	21.9	3.05	
17	73.0	43.8	5.08	36.5	4.16	29.2	3.48	21.9	3.04	
15	73.0	43.8	5.03	36.5	4.13	29.2	3.46	21.9	3.03	

TC : Total Capacity PI : Power Input
Indoor air temperature conditions : 27.0 °C dry-bulb / 19.0 °C wet bulb

Heating

Outdoor Unit Dry-Bulb (°C) Wet-Bulb (°C) Heating Capacity (kW)			Compressor + Outdoor Fan Power consumption (kW)							
			100 %		90 %		80 %		70 %	
			TC (kW)	PI (kW)	TC (kW)	PI (kW)	TC (kW)	PI (kW)	TC (kW)	PI (kW)
15.0	13.7	81.5	81.5	15.4	73.4	12.8	65.2	10.7	57.1	8.88
13.0	11.8	81.5	81.5	16.1	73.4	13.3	65.2	11.0	57.1	9.08
11.0	9.8	81.5	81.5	16.8	73.4	13.8	65.2	11.3	57.1	9.31
9.0	7.9	81.5	81.5	17.6	73.4	14.4	65.2	11.7	57.1	9.58
7.0	6.0	81.5	81.5	18.6	73.4	15.0	65.2	12.2	57.1	9.89
5.0	4.1	78.7	78.7	18.3	70.9	14.8	63.0	12.0	55.1	9.74
3.0	2.2	75.9	75.9	18.0	68.3	14.6	60.7	11.8	53.1	9.59
0.0	-0.7	71.5	71.5	17.6	64.3	14.2	57.2	11.5	50.0	9.36
-3.0	-3.7	66.8	66.8	17.1	60.1	13.9	53.4	11.2	46.8	9.12
-5.0	-5.6	63.8	63.8	16.8	57.4	13.6	51.0	11.1	44.6	8.97
-7.0	-7.6	60.5	60.5	16.5	54.4	13.4	48.4	10.9	42.3	8.81
-10	-10.5	55.7	55.7	16.1	50.1	13.1	44.5	10.6	39.0	8.58
-14.5	-15.0	47.9	47.9	15.4	43.1	12.5	38.3	10.1	33.5	8.23

Outdoor Unit Dry-Bulb (°C) Wet-Bulb (°C) Heating Capacity (kW)			Compressor + Outdoor Fan Power consumption (kW)							
			60 %		50 %		40 %		30 %	
			TC (kW)	PI (kW)	TC (kW)	PI (kW)	TC (kW)	PI (kW)	TC (kW)	PI (kW)
15.0	13.7	81.5	48.9	7.41	40.8	6.16	32.6	5.05	24.5	4.02
13.0	11.8	81.5	48.9	7.53	40.8	6.23	32.6	5.10	24.5	4.04
11.0	9.8	81.5	48.9	7.68	40.8	6.33	32.6	5.16	24.5	4.08
9.0	7.9	81.5	48.9	7.85	40.8	6.43	32.6	5.22	24.5	4.12
7.0	6.0	81.5	48.9	8.04	40.8	6.55	32.6	5.29	24.5	4.16
5.0	4.1	78.7	47.2	7.92	39.4	6.45	31.5	5.21	23.6	4.10
3.0	2.2	75.9	45.5	7.80	38.0	6.35	30.4	5.13	22.8	4.04
0.0	-0.7	71.5	42.9	7.61	35.7	6.20	28.6	5.01	21.4	3.94
-3.0	-3.7	66.8	40.1	7.42	33.4	6.04	26.7	4.88	20.0	3.84
-5.0	-5.6	63.8	38.3	7.30	31.9	5.94	25.5	4.80	19.1	3.78
-7.0	-7.6	60.5	36.3	7.17	30.2	5.84	24.2	4.71	18.1	3.71
-10	-10.5	55.7	33.4	6.98	27.8	5.68	22.3	4.59	16.7	3.61
-14.5	-15.0	47.9	28.7	6.69	24.0	5.45	19.2	4.40	14.4	3.46

TC : Total Capacity PI : Power Input
Indoor air temperature conditions : 20.0 °C dry-bulb



MMY-AP2824HT8P-E, AP2824T8P-E (28HP, 78.5 kW system)

Cooling

Outdoor Unit Dry-Bulb (°C)		Outdoor Unit 100 % Cooling Capacity (kW)	Compressor + Outdoor Fan Power consumption (kW)							
			100 %		90 %		80 %		70 %	
			TC (kW)	PI (kW)	TC (kW)	PI (kW)	TC (kW)	PI (kW)	TC (kW)	PI (kW)
40	73.1	73.1	21.9	65.7	18.0	58.4	14.6	51.1	11.7	
39	74.2	74.2	21.6	66.8	17.7	59.4	14.4	52.0	11.5	
37	76.4	76.4	20.9	68.8	17.2	61.2	13.9	53.5	11.1	
35	78.5	78.5	20.3	70.7	16.7	62.8	13.5	55.0	10.8	
33	78.5	78.5	18.7	70.7	15.4	62.8	12.5	55.0	10.0	
31	78.5	78.5	17.4	70.7	14.3	62.8	11.7	55.0	9.38	
30	78.5	78.5	16.8	70.7	13.8	62.8	11.3	55.0	9.07	
29	78.5	78.5	16.2	70.7	13.4	62.8	10.9	55.0	8.78	
27	78.5	78.5	15.1	70.7	12.5	62.8	10.2	55.0	8.23	
25	78.5	78.5	14.1	70.7	11.6	62.8	9.53	55.0	7.72	
23	78.5	78.5	13.2	70.7	10.9	62.8	8.93	55.0	7.25	
21	78.5	78.5	12.9	70.7	10.7	62.8	8.76	55.0	7.12	
20	78.5	78.5	12.7	70.7	10.6	62.8	8.68	55.0	7.07	
19	78.5	78.5	12.6	70.7	10.5	62.8	8.61	55.0	7.01	
17	78.5	78.5	12.4	70.7	10.3	62.8	8.49	55.0	6.92	
15	78.5	78.5	12.2	70.7	10.2	62.8	8.38	55.0	6.84	

Outdoor Unit Dry-Bulb (°C)		Outdoor Unit 100 % Cooling Capacity (kW)	Compressor + Outdoor Fan Power consumption (kW)							
			60 %		50 %		40 %		30 %	
			TC (kW)	PI (kW)	TC (kW)	PI (kW)	TC (kW)	PI (kW)	TC (kW)	PI (kW)
40	73.1	43.8	9.22	36.5	7.27	29.2	5.81	21.9	4.83	
39	74.2	44.5	9.09	37.1	7.16	29.7	5.72	22.3	4.75	
37	76.4	45.9	8.81	38.2	6.95	30.6	5.55	22.9	4.61	
35	78.5	47.1	8.54	39.3	6.73	31.4	5.37	23.6	4.46	
33	78.5	47.1	7.98	39.3	6.33	31.4	5.09	23.6	4.27	
31	78.5	47.1	7.48	39.3	5.97	31.4	4.84	23.6	4.09	
30	78.5	47.1	7.25	39.3	5.80	31.4	4.71	23.6	4.00	
29	78.5	47.1	7.03	39.3	5.63	31.4	4.59	23.6	3.91	
27	78.5	47.1	6.61	39.3	5.32	31.4	4.36	23.6	3.74	
25	78.5	47.1	6.22	39.3	5.03	31.4	4.14	23.6	3.57	
23	78.5	47.1	5.86	39.3	4.75	31.4	3.93	23.6	3.40	
21	78.5	47.1	5.77	39.3	4.69	31.4	3.90	23.6	3.39	
20	78.5	47.1	5.73	39.3	4.67	31.4	3.89	23.6	3.38	
19	78.5	47.1	5.69	39.3	4.65	31.4	3.87	23.6	3.38	
17	78.5	47.1	5.63	39.3	4.60	31.4	3.85	23.6	3.37	
15	78.5	47.1	5.57	39.3	4.57	31.4	3.83	23.6	3.36	

TC : Total Capacity PI : Power Input
Indoor air temperature conditions : 27.0 °C dry-bulb / 19.0 °C wet bulb

Heating

Outdoor Unit Dry-Bulb (°C) Wet-Bulb (°C) Heating Capacity (kW)			Compressor + Outdoor Fan Power consumption (kW)							
			100 %		90 %		80 %		70 %	
			TC (kW)	PI (kW)	TC (kW)	PI (kW)	TC (kW)	PI (kW)	TC (kW)	PI (kW)
15.0	13.7	88.0	88.0	17.1	79.2	14.2	70.4	11.8	61.6	9.82
13.0	11.8	88.0	88.0	17.8	79.2	14.7	70.4	12.1	61.6	10.0
11.0	9.8	88.0	88.0	18.6	79.2	15.2	70.4	12.5	61.6	10.3
9.0	7.9	88.0	88.0	19.5	79.2	15.9	70.4	13.0	61.6	10.6
7.0	6.0	88.0	88.0	20.5	79.2	16.6	70.4	13.5	61.6	10.9
5.0	4.1	85.0	85.0	20.2	76.5	16.4	68.0	13.3	59.5	10.8
3.0	2.2	82.0	82.0	19.9	73.8	16.1	65.6	13.1	57.4	10.6
0.0	-0.7	77.2	77.2	19.4	69.5	15.7	61.8	12.8	54.0	10.3
-3.0	-3.7	72.1	72.1	18.9	64.9	15.3	57.7	12.4	50.5	10.1
-5.0	-5.6	68.8	68.8	18.6	62.0	15.1	55.1	12.2	48.2	9.92
-7.0	-7.6	65.3	65.3	18.3	58.8	14.8	52.3	12.0	45.7	9.75
-10	-10.5	60.1	60.1	17.8	54.1	14.4	48.1	11.7	42.1	9.49
-14.5	-15.0	51.7	51.7	17.1	46.6	13.8	41.4	11.2	36.2	9.10

Outdoor Unit Dry-Bulb (°C) Wet-Bulb (°C) Heating Capacity (kW)			Compressor + Outdoor Fan Power consumption (kW)							
			60 %		50 %		40 %		30 %	
			TC (kW)	PI (kW)	TC (kW)	PI (kW)	TC (kW)	PI (kW)	TC (kW)	PI (kW)
15.0	13.7	88.0	52.8	8.19	44.0	6.81	35.2	5.59	26.4	4.44
13.0	11.8	88.0	52.8	8.33	44.0	6.89	35.2	5.64	26.4	4.47
11.0	9.8	88.0	52.8	8.50	44.0	7.00	35.2	5.70	26.4	4.51
9.0	7.9	88.0	52.8	8.68	44.0	7.11	35.2	5.77	26.4	4.56
7.0	6.0	88.0	52.8	8.90	44.0	7.24	35.2	5.85	26.4	4.60
5.0	4.1	85.0	51.0	8.76	42.5	7.13	34.0	5.76	25.5	4.53
3.0	2.2	82.0	49.2	8.63	41.0	7.02	32.8	5.67	24.6	4.46
0.0	-0.7	77.2	46.3	8.42	38.6	6.85	30.9	5.54	23.2	4.36
-3.0	-3.7	72.1	43.3	8.21	36.1	6.68	28.9	5.40	21.6	4.25
-5.0	-5.6	68.8	41.3	8.07	34.4	6.57	27.5	5.31	20.7	4.18
-7.0	-7.6	65.3	39.2	7.93	32.7	6.45	26.1	5.21	19.6	4.10
-10	-10.5	60.1	36.1	7.72	30.0	6.29	24.0	5.08	18.0	4.00
-14.5	-15.0	51.7	31.0	7.40	25.9	6.03	20.7	4.87	15.5	3.83

TC : Total Capacity PI : Power Input
Indoor air temperature conditions : 20.0 °C dry-bulb



MMY-AP3024HT8P-E, AP3024T8P-E (30HP, 85 kW system)

Cooling

Outdoor Unit Dry-Bulb (°C)		Outdoor Unit 100 % Cooling Capacity (kW)	Compressor + Outdoor Fan Power consumption (kW)							
			100 %		90 %		80 %		70 %	
			TC (kW)	PI (kW)	TC (kW)	PI (kW)	TC (kW)	PI (kW)	TC (kW)	PI (kW)
40	79.1	79.1	24.6	71.2	20.2	63.3	16.4	55.4	13.1	
39	80.4	80.4	24.2	72.3	19.9	64.3	16.1	56.3	12.9	
37	82.8	82.8	23.5	74.5	19.3	66.2	15.6	57.9	12.5	
35	85.0	85.0	22.8	76.5	18.7	68.0	15.1	59.5	12.1	
33	85.0	85.0	21.0	76.5	17.3	68.0	14.1	59.5	11.3	
31	85.0	85.0	19.5	76.5	16.1	68.0	13.1	59.5	10.5	
30	85.0	85.0	18.8	76.5	15.5	68.0	12.6	59.5	10.2	
29	85.0	85.0	18.1	76.5	15.0	68.0	12.2	59.5	9.85	
27	85.0	85.0	16.9	76.5	14.0	68.0	11.4	59.5	9.24	
25	85.0	85.0	15.8	76.5	13.1	68.0	10.7	59.5	8.67	
23	85.0	85.0	14.8	76.5	12.2	68.0	10.0	59.5	8.14	
21	85.0	85.0	14.4	76.5	12.0	68.0	9.83	59.5	7.99	
20	85.0	85.0	14.3	76.5	11.9	68.0	9.74	59.5	7.93	
19	85.0	85.0	14.2	76.5	11.8	68.0	9.67	59.5	7.87	
17	85.0	85.0	13.9	76.5	11.6	68.0	9.52	59.5	7.77	
15	85.0	85.0	13.7	76.5	11.4	68.0	9.40	59.5	7.68	

Outdoor Unit Dry-Bulb (°C)		Outdoor Unit 100 % Cooling Capacity (kW)	Compressor + Outdoor Fan Power consumption (kW)							
			60 %		50 %		40 %		30 %	
			TC (kW)	PI (kW)	TC (kW)	PI (kW)	TC (kW)	PI (kW)	TC (kW)	PI (kW)
40	79.1	47.5	10.4	39.5	8.16	31.6	6.52	23.7	5.42	
39	80.4	48.2	10.2	40.2	8.04	32.1	6.42	24.1	5.34	
37	82.8	49.7	9.89	41.4	7.80	33.1	6.23	24.8	5.17	
35	85.0	51.0	9.58	42.5	7.55	34.0	6.03	25.5	5.01	
33	85.0	51.0	8.96	42.5	7.10	34.0	5.72	25.5	4.79	
31	85.0	51.0	8.40	42.5	6.70	34.0	5.43	25.5	4.59	
30	85.0	51.0	8.14	42.5	6.51	34.0	5.29	25.5	4.49	
29	85.0	51.0	7.89	42.5	6.32	34.0	5.15	25.5	4.39	
27	85.0	51.0	7.42	42.5	5.97	34.0	4.90	25.5	4.19	
25	85.0	51.0	6.98	42.5	5.64	34.0	4.65	25.5	4.00	
23	85.0	51.0	6.57	42.5	5.33	34.0	4.41	25.5	3.82	
21	85.0	51.0	6.47	42.5	5.27	34.0	4.38	25.5	3.80	
20	85.0	51.0	6.43	42.5	5.24	34.0	4.36	25.5	3.80	
19	85.0	51.0	6.39	42.5	5.21	34.0	4.35	25.5	3.79	
17	85.0	51.0	6.32	42.5	5.17	34.0	4.32	25.5	3.78	
15	85.0	51.0	6.26	42.5	5.13	34.0	4.30	25.5	3.77	

TC : Total Capacity PI : Power Input
Indoor air temperature conditions : 27.0 °C dry-bulb / 19.0 °C wet bulb

Heating

Outdoor Unit Dry-Bulb (°C) Wet-Bulb (°C)			Outdoor Unit 100 % Heating Capacity (kW)	Compressor + Outdoor Fan Power consumption (kW)							
				100 %		90 %		80 %		70 %	
				TC (kW)	PI (kW)	TC (kW)	PI (kW)	TC (kW)	PI (kW)	TC (kW)	PI (kW)
15.0	13.7	95.0	95.0	18.9	85.5	15.7	76.0	13.0	66.5	10.9	
13.0	11.8	95.0	95.0	19.6	85.5	16.2	76.0	13.4	66.5	11.1	
11.0	9.8	95.0	95.0	20.5	85.5	16.9	76.0	13.8	66.5	11.4	
9.0	7.9	95.0	95.0	21.5	85.5	17.6	76.0	14.3	66.5	11.7	
7.0	6.0	95.0	95.0	22.7	85.5	18.4	76.0	14.9	66.5	12.1	
5.0	4.1	91.8	91.8	22.4	82.6	18.1	73.4	14.7	64.2	11.9	
3.0	2.2	88.5	88.5	22.0	79.6	17.8	70.8	14.5	61.9	11.7	
0.0	-0.7	83.3	83.3	21.5	75.0	17.4	66.7	14.1	58.3	11.4	
-3.0	-3.7	77.9	77.9	20.9	70.1	17.0	62.3	13.7	54.5	11.2	
-5.0	-5.6	74.3	74.3	20.6	66.9	16.7	59.5	13.5	52.0	11.0	
-7.0	-7.6	70.5	70.5	20.2	63.5	16.4	56.4	13.3	49.4	10.8	
-10	-10.5	64.9	64.9	19.7	58.4	16.0	51.9	12.9	45.4	10.5	
-14.5	-15.0	55.8	55.8	18.9	50.3	15.3	44.7	12.4	39.1	10.1	

Outdoor Unit Dry-Bulb (°C) Wet-Bulb (°C)			Outdoor Unit 100 % Heating Capacity (kW)	Compressor + Outdoor Fan Power consumption (kW)							
				60 %		50 %		40 %		30 %	
				TC (kW)	PI (kW)	TC (kW)	PI (kW)	TC (kW)	PI (kW)	TC (kW)	PI (kW)
15.0	13.7	95.0	57.0	9.06	47.5	7.53	38.0	6.18	28.5	4.91	
13.0	11.8	95.0	57.0	9.21	47.5	7.63	38.0	6.24	28.5	4.95	
11.0	9.8	95.0	57.0	9.40	47.5	7.74	38.0	6.31	28.5	4.99	
9.0	7.9	95.0	57.0	9.60	47.5	7.87	38.0	6.38	28.5	5.04	
7.0	6.0	95.0	57.0	9.84	47.5	8.01	38.0	6.47	28.5	5.09	
5.0	4.1	91.8	55.1	9.69	45.9	7.89	36.7	6.37	27.5	5.02	
3.0	2.2	88.5	53.1	9.54	44.2	7.77	35.4	6.28	26.5	4.94	
0.0	-0.7	83.3	50.0	9.31	41.7	7.58	33.3	6.13	25.0	4.82	
-3.0	-3.7	77.9	46.7	9.08	38.9	7.39	31.1	5.97	23.4	4.70	
-5.0	-5.6	74.3	44.6	8.93	37.2	7.27	29.7	5.87	22.3	4.62	
-7.0	-7.6	70.5	42.3	8.77	35.3	7.14	28.2	5.77	21.2	4.54	
-10	-10.5	64.9	38.9	8.54	32.4	6.95	26.0	5.62	19.5	4.42	
-14.5	-15.0	55.8	33.5	8.19	27.9	6.67	22.3	5.38	16.8	4.24	

TC : Total Capacity PI : Power Input
Indoor air temperature conditions : 20.0 °C dry-bulb



MMY-AP3224HT8P-E, AP3224T8P-E (32HP, 90 kW system)

Cooling

Outdoor Unit Dry-Bulb (°C)		Outdoor Unit 100 % Cooling Capacity (kW)	Compressor + Outdoor Fan Power consumption (kW)							
			100 %		90 %		80 %		70 %	
			TC (kW)	PI (kW)	TC (kW)	PI (kW)	TC (kW)	PI (kW)	TC (kW)	PI (kW)
40		83.8	23.5	75.4	19.3	67.0	15.7	58.6	12.5	
39		85.1	23.2	76.6	19.1	68.1	15.4	59.6	12.4	
37		87.6	22.5	78.9	18.5	70.1	15.0	61.3	12.0	
35		90.0	21.8	81.0	17.9	72.0	14.5	63.0	11.6	
33		90.0	20.1	81.0	16.6	72.0	13.5	63.0	10.8	
31		90.0	18.7	81.0	15.4	72.0	12.5	63.0	10.1	
30		90.0	18.0	81.0	14.9	72.0	12.1	63.0	9.75	
29		90.0	17.4	81.0	14.4	72.0	11.7	63.0	9.44	
27		90.0	16.2	81.0	13.4	72.0	10.9	63.0	8.85	
25		90.0	15.1	81.0	12.5	72.0	10.2	63.0	8.30	
23		90.0	14.1	81.0	11.7	72.0	9.60	63.0	7.79	
21		90.0	13.8	81.0	11.5	72.0	9.42	63.0	7.66	
20		90.0	13.7	81.0	11.4	72.0	9.33	63.0	7.60	
19		90.0	13.6	81.0	11.3	72.0	9.26	63.0	7.54	
17		90.0	13.4	81.0	11.1	72.0	9.12	63.0	7.44	
15		90.0	13.2	81.0	10.9	72.0	9.01	63.0	7.36	

Outdoor Unit Dry-Bulb (°C)		Outdoor Unit 100 % Cooling Capacity (kW)	Compressor + Outdoor Fan Power consumption (kW)							
			60 %		50 %		40 %		30 %	
			TC (kW)	PI (kW)	TC (kW)	PI (kW)	TC (kW)	PI (kW)	TC (kW)	PI (kW)
40		83.8	50.3	9.92	41.9	7.82	33.5	6.24	25.1	5.19
39		85.1	51.1	9.77	42.5	7.70	34.0	6.15	25.5	5.11
37		87.6	52.6	9.47	43.8	7.47	35.1	5.96	26.3	4.96
35		90.0	54.0	9.18	45.0	7.23	36.0	5.77	27.0	4.80
33		90.0	54.0	8.58	45.0	6.80	36.0	5.48	27.0	4.59
31		90.0	54.0	8.04	45.0	6.41	36.0	5.20	27.0	4.39
30		90.0	54.0	7.79	45.0	6.23	36.0	5.07	27.0	4.30
29		90.0	54.0	7.55	45.0	6.05	36.0	4.94	27.0	4.20
27		90.0	54.0	7.10	45.0	5.72	36.0	4.69	27.0	4.02
25		90.0	54.0	6.69	45.0	5.40	36.0	4.45	27.0	3.84
23		90.0	54.0	6.29	45.0	5.11	36.0	4.23	27.0	3.66
21		90.0	54.0	6.20	45.0	5.05	36.0	4.19	27.0	3.64
20		90.0	54.0	6.16	45.0	5.02	36.0	4.18	27.0	3.64
19		90.0	54.0	6.12	45.0	4.99	36.0	4.16	27.0	3.63
17		90.0	54.0	6.05	45.0	4.95	36.0	4.14	27.0	3.62
15		90.0	54.0	5.99	45.0	4.91	36.0	4.12	27.0	3.61

TC : Total Capacity PI : Power Input
Indoor air temperature conditions : 27.0 °C dry-bulb / 19.0 °C wet bulb

Heating

Outdoor Unit Dry-Bulb (°C) Wet-Bulb (°C) Heating Capacity (kW)			Compressor + Outdoor Fan Power consumption (kW)							
			100 %		90 %		80 %		70 %	
			TC (kW)	PI (kW)	TC (kW)	PI (kW)	TC (kW)	PI (kW)	TC (kW)	PI (kW)
15.0	13.7	100.0	100.0	18.4	90.0	15.3	80.0	12.7	70.0	10.6
13.0	11.8	100.0	100.0	19.1	90.0	15.8	80.0	13.1	70.0	10.8
11.0	9.8	100.0	100.0	20.0	90.0	16.4	80.0	13.5	70.0	11.1
9.0	7.9	100.0	100.0	21.0	90.0	17.1	80.0	14.0	70.0	11.4
7.0	6.0	100.0	100.0	22.1	90.0	17.9	80.0	14.5	70.0	11.8
5.0	4.1	96.6	96.6	21.8	86.9	17.6	77.3	14.3	67.6	11.6
3.0	2.2	93.1	93.1	21.4	83.8	17.4	74.5	14.1	65.2	11.4
0.0	-0.7	87.7	87.7	20.9	79.0	17.0	70.2	13.7	61.4	11.2
-3.0	-3.7	82.0	82.0	20.4	73.8	16.5	65.6	13.4	57.4	10.9
-5.0	-5.6	78.2	78.2	20.1	70.4	16.3	62.6	13.2	54.8	10.7
-7.0	-7.6	74.2	74.2	19.7	66.8	16.0	59.4	12.9	52.0	10.5
-10	-10.5	68.3	68.3	19.2	61.5	15.6	54.6	12.6	47.8	10.2
-14.5	-15.0	58.8	58.8	18.4	52.9	14.9	47.0	12.1	41.1	9.80

Outdoor Unit Dry-Bulb (°C) Wet-Bulb (°C) Heating Capacity (kW)			Compressor + Outdoor Fan Power consumption (kW)							
			60 %		50 %		40 %		30 %	
			TC (kW)	PI (kW)	TC (kW)	PI (kW)	TC (kW)	PI (kW)	TC (kW)	PI (kW)
15.0	13.7	100.0	60.0	8.83	50.0	7.34	40.0	6.02	30.0	4.79
13.0	11.8	100.0	60.0	8.97	50.0	7.43	40.0	6.08	30.0	4.82
11.0	9.8	100.0	60.0	9.15	50.0	7.54	40.0	6.14	30.0	4.86
9.0	7.9	100.0	60.0	9.35	50.0	7.66	40.0	6.22	30.0	4.91
7.0	6.0	100.0	60.0	9.59	50.0	7.80	40.0	6.30	30.0	4.96
5.0	4.1	96.6	58.0	9.44	48.3	7.68	38.6	6.21	29.0	4.89
3.0	2.2	93.1	55.9	9.30	46.6	7.57	37.3	6.11	27.9	4.81
0.0	-0.7	87.7	52.6	9.07	43.9	7.39	35.1	5.97	26.3	4.70
-3.0	-3.7	82.0	49.2	8.84	41.0	7.20	32.8	5.81	24.6	4.58
-5.0	-5.6	78.2	46.9	8.70	39.1	7.08	31.3	5.72	23.5	4.50
-7.0	-7.6	74.2	44.5	8.54	37.1	6.95	29.7	5.62	22.3	4.42
-10	-10.5	68.3	41.0	8.32	34.1	6.77	27.3	5.47	20.5	4.31
-14.5	-15.0	58.8	35.3	7.98	29.4	6.49	23.5	5.25	17.6	4.13

TC : Total Capacity PI : Power Input
Indoor air temperature conditions : 20.0 °C dry-bulb



MMY-AP3424HT8P-E, AP3424T8P-E (34HP, 96 kW system)

Cooling

Outdoor Unit Dry-Bulb (°C)		Outdoor Unit 100 % Cooling Capacity (kW)	Compressor + Outdoor Fan Power consumption (kW)							
			100 %		90 %		80 %		70 %	
			TC (kW)	PI (kW)	TC (kW)	PI (kW)	TC (kW)	PI (kW)	TC (kW)	PI (kW)
40	89.3	89.3	25.9	80.4	21.3	71.5	17.3	62.5	13.8	
39	90.8	90.8	25.5	81.7	21.0	72.6	17.0	63.5	13.6	
37	93.5	93.5	24.8	84.1	20.4	74.8	16.5	65.4	13.2	
35	96.0	96.0	24.0	86.4	19.7	76.8	16.0	67.2	12.8	
33	96.0	96.0	22.2	86.4	18.3	76.8	14.8	67.2	11.9	
31	96.0	96.0	20.6	86.4	17.0	76.8	13.8	67.2	11.1	
30	96.0	96.0	19.8	86.4	16.4	76.8	13.3	67.2	10.7	
29	96.0	96.0	19.1	86.4	15.8	76.8	12.9	67.2	10.4	
27	96.0	96.0	17.8	86.4	14.8	76.8	12.1	67.2	9.74	
25	96.0	96.0	16.7	86.4	13.8	76.8	11.3	67.2	9.14	
23	96.0	96.0	15.6	86.4	12.9	76.8	10.6	67.2	8.58	
21	96.0	96.0	15.2	86.4	12.6	76.8	10.4	67.2	8.43	
20	96.0	96.0	15.1	86.4	12.5	76.8	10.3	67.2	8.37	
19	96.0	96.0	15.0	86.4	12.4	76.8	10.2	67.2	8.31	
17	96.0	96.0	14.7	86.4	12.2	76.8	10.0	67.2	8.20	
15	96.0	96.0	14.5	86.4	12.1	76.8	9.92	67.2	8.10	

Outdoor Unit Dry-Bulb (°C)		Outdoor Unit 100 % Cooling Capacity (kW)	Compressor + Outdoor Fan Power consumption (kW)							
			60 %		50 %		40 %		30 %	
			TC (kW)	PI (kW)	TC (kW)	PI (kW)	TC (kW)	PI (kW)	TC (kW)	PI (kW)
40	89.3	53.6	10.9	44.7	8.61	35.7	6.87	26.8	5.71	
39	90.8	54.5	10.8	45.4	8.48	36.3	6.77	27.2	5.63	
37	93.5	56.1	10.4	46.7	8.23	37.4	6.57	28.0	5.46	
35	96.0	57.6	10.1	48.0	7.97	38.4	6.36	28.8	5.29	
33	96.0	57.6	9.45	48.0	7.50	38.4	6.03	28.8	5.06	
31	96.0	57.6	8.86	48.0	7.07	38.4	5.73	28.8	4.84	
30	96.0	57.6	8.58	48.0	6.86	38.4	5.58	28.8	4.73	
29	96.0	57.6	8.32	48.0	6.67	38.4	5.44	28.8	4.63	
27	96.0	57.6	7.83	48.0	6.30	38.4	5.17	28.8	4.42	
25	96.0	57.6	7.36	48.0	5.95	38.4	4.91	28.8	4.22	
23	96.0	57.6	6.93	48.0	5.62	38.4	4.66	28.8	4.03	
21	96.0	57.6	6.83	48.0	5.56	38.4	4.62	28.8	4.01	
20	96.0	57.6	6.78	48.0	5.53	38.4	4.60	28.8	4.00	
19	96.0	57.6	6.74	48.0	5.50	38.4	4.59	28.8	4.00	
17	96.0	57.6	6.66	48.0	5.45	38.4	4.56	28.8	3.99	
15	96.0	57.6	6.60	48.0	5.41	38.4	4.54	28.8	3.98	

TC : Total Capacity PI : Power Input
Indoor air temperature conditions : 27.0 °C dry-bulb / 19.0 °C wet bulb

Heating

Outdoor Unit Dry-Bulb (°C) Wet-Bulb (°C)			Outdoor Unit 100 % Heating Capacity (kW)	Compressor + Outdoor Fan Power consumption (kW)							
				100 %		90 %		80 %		70 %	
				TC (kW)	PI (kW)	TC (kW)	PI (kW)	TC (kW)	PI (kW)	TC (kW)	PI (kW)
15.0	13.7	108.0	108.0	20.6	97.2	17.1	86.4	14.2	75.6	11.8	
13.0	11.8	108.0	108.0	21.4	97.2	17.6	86.4	14.6	75.6	12.1	
11.0	9.8	108.0	108.0	22.3	97.2	18.3	86.4	15.1	75.6	12.4	
9.0	7.9	108.0	108.0	23.4	97.2	19.1	86.4	15.6	75.6	12.7	
7.0	6.0	108.0	108.0	24.7	97.2	20.0	86.4	16.2	75.6	13.2	
5.0	4.1	104.3	104.3	24.3	93.9	19.7	83.5	16.0	73.0	13.0	
3.0	2.2	100.6	100.6	23.9	90.5	19.4	80.5	15.7	70.4	12.8	
0.0	-0.7	94.7	94.7	23.4	85.3	18.9	75.8	15.3	66.3	12.5	
-3.0	-3.7	88.5	88.5	22.8	79.7	18.5	70.8	15.0	62.0	12.1	
-5.0	-5.6	84.5	84.5	22.4	76.0	18.2	67.6	14.7	59.1	11.9	
-7.0	-7.6	80.2	80.2	22.0	72.2	17.8	64.1	14.4	56.1	11.7	
-10	-10.5	73.8	73.8	21.4	66.4	17.4	59.0	14.1	51.6	11.4	
-14.5	-15.0	63.5	63.5	20.5	57.1	16.6	50.8	13.5	44.4	10.9	

Outdoor Unit Dry-Bulb (°C) Wet-Bulb (°C)			Outdoor Unit 100 % Heating Capacity (kW)	Compressor + Outdoor Fan Power consumption (kW)							
				60 %		50 %		40 %		30 %	
				TC (kW)	PI (kW)	TC (kW)	PI (kW)	TC (kW)	PI (kW)	TC (kW)	PI (kW)
15.0	13.7	108.0	64.8	9.86	54.0	8.19	43.2	6.72	32.4	5.34	
13.0	11.8	108.0	64.8	10.0	54.0	8.29	43.2	6.78	32.4	5.38	
11.0	9.8	108.0	64.8	10.2	54.0	8.42	43.2	6.86	32.4	5.43	
9.0	7.9	108.0	64.8	10.4	54.0	8.55	43.2	6.94	32.4	5.48	
7.0	6.0	108.0	64.8	10.7	54.0	8.71	43.2	7.04	32.4	5.54	
5.0	4.1	104.3	62.6	10.5	52.2	8.58	41.7	6.93	31.3	5.46	
3.0	2.2	100.6	60.4	10.4	50.3	8.45	40.2	6.83	30.2	5.37	
0.0	-0.7	94.7	56.8	10.1	47.4	8.25	37.9	6.66	28.4	5.24	
-3.0	-3.7	88.5	53.1	9.87	44.3	8.04	35.4	6.49	26.6	5.11	
-5.0	-5.6	84.5	50.7	9.71	42.2	7.90	33.8	6.39	25.3	5.03	
-7.0	-7.6	80.2	48.1	9.54	40.1	7.77	32.1	6.27	24.1	4.94	
-10	-10.5	73.8	44.3	9.29	36.9	7.56	29.5	6.11	22.1	4.81	
-14.5	-15.0	63.5	38.1	8.91	31.7	7.25	25.4	5.86	19.0	4.61	

TC : Total Capacity PI : Power Input
Indoor air temperature conditions : 20.0 °C dry-bulb



MMY-AP3624HT8P-E, AP3624T8P-E (36HP, 101 kW system)

Cooling

Outdoor Unit Dry-Bulb (°C)		Outdoor Unit 100 % Cooling Capacity (kW)	Compressor + Outdoor Fan Power consumption (kW)							
			100 %		90 %		80 %		70 %	
			TC (kW)	PI (kW)	TC (kW)	PI (kW)	TC (kW)	PI (kW)	TC (kW)	PI (kW)
40	94.0	94.0	27.8	84.6	22.8	75.2	18.5	65.8	14.8	
39	95.5	95.5	27.4	85.9	22.5	76.4	18.2	66.8	14.6	
37	98.3	98.3	26.5	88.5	21.8	78.7	17.7	68.8	14.1	
35	101.0	101.0	25.7	90.9	21.1	80.8	17.1	70.7	13.7	
33	101.0	101.0	23.8	90.9	19.6	80.8	15.9	70.7	12.7	
31	101.0	101.0	22.1	90.9	18.2	80.8	14.8	70.7	11.9	
30	101.0	101.0	21.3	90.9	17.5	80.8	14.3	70.7	11.5	
29	101.0	101.0	20.5	90.9	16.9	80.8	13.8	70.7	11.1	
27	101.0	101.0	19.1	90.9	15.8	80.8	12.9	70.7	10.4	
25	101.0	101.0	17.9	90.9	14.8	80.8	12.1	70.7	9.80	
23	101.0	101.0	16.7	90.9	13.8	80.8	11.3	70.7	9.20	
21	101.0	101.0	16.3	90.9	13.5	80.8	11.1	70.7	9.04	
20	101.0	101.0	16.2	90.9	13.4	80.8	11.0	70.7	8.97	
19	101.0	101.0	16.0	90.9	13.3	80.8	10.9	70.7	8.90	
17	101.0	101.0	15.8	90.9	13.1	80.8	10.8	70.7	8.78	
15	101.0	101.0	15.5	90.9	12.9	80.8	10.6	70.7	8.68	

Outdoor Unit Dry-Bulb (°C)		Outdoor Unit 100 % Cooling Capacity (kW)	Compressor + Outdoor Fan Power consumption (kW)							
			60 %		50 %		40 %		30 %	
			TC (kW)	PI (kW)	TC (kW)	PI (kW)	TC (kW)	PI (kW)	TC (kW)	PI (kW)
40	94.0	56.4	11.7	47.0	9.23	37.6	7.37	28.2	6.12	
39	95.5	57.3	11.5	47.7	9.09	38.2	7.26	28.6	6.03	
37	98.3	59.0	11.2	49.2	8.81	39.3	7.04	29.5	5.85	
35	101.0	60.6	10.8	50.5	8.54	40.4	6.82	30.3	5.67	
33	101.0	60.6	10.1	50.5	8.03	40.4	6.46	30.3	5.42	
31	101.0	60.6	9.49	50.5	7.57	40.4	6.14	30.3	5.19	
30	101.0	60.6	9.20	50.5	7.35	40.4	5.98	30.3	5.07	
29	101.0	60.6	8.92	50.5	7.15	40.4	5.83	30.3	4.96	
27	101.0	60.6	8.39	50.5	6.75	40.4	5.54	30.3	4.74	
25	101.0	60.6	7.89	50.5	6.38	40.4	5.26	30.3	4.53	
23	101.0	60.6	7.43	50.5	6.03	40.4	4.99	30.3	4.32	
21	101.0	60.6	7.32	50.5	5.96	40.4	4.95	30.3	4.30	
20	101.0	60.6	7.27	50.5	5.92	40.4	4.93	30.3	4.29	
19	101.0	60.6	7.22	50.5	5.89	40.4	4.92	30.3	4.28	
17	101.0	60.6	7.14	50.5	5.84	40.4	4.89	30.3	4.27	
15	101.0	60.6	7.07	50.5	5.80	40.4	4.86	30.3	4.26	

TC : Total Capacity PI : Power Input
Indoor air temperature conditions : 27.0 °C dry-bulb / 19.0 °C wet bulb

Heating

Outdoor Unit Dry-Bulb (°C)		Outdoor Unit Wet-Bulb (°C)	Outdoor Unit 100 % Heating Capacity (kW)	Compressor + Outdoor Fan Power consumption (kW)							
				100 %		90 %		80 %		70 %	
				TC (kW)	PI (kW)	TC (kW)	PI (kW)	TC (kW)	PI (kW)	TC (kW)	PI (kW)
15.0	13.7	113.0	113.0	21.7	101.7	18.0	90.4	15.0	79.1	12.5	
13.0	11.8	113.0	113.0	22.5	101.7	18.6	90.4	15.4	79.1	12.7	
11.0	9.8	113.0	113.0	23.6	101.7	19.3	90.4	15.9	79.1	13.1	
9.0	7.9	113.0	113.0	24.7	101.7	20.2	90.4	16.5	79.1	13.4	
7.0	6.0	113.0	113.0	26.1	101.7	21.1	90.4	17.1	79.1	13.9	
5.0	4.1	109.2	109.2	25.7	98.2	20.8	87.3	16.8	76.4	13.7	
3.0	2.2	105.2	105.2	25.3	94.7	20.5	84.2	16.6	73.7	13.5	
0.0	-0.7	99.1	99.1	24.7	89.2	20.0	79.3	16.2	69.4	13.1	
-3.0	-3.7	92.6	92.6	24.0	83.4	19.5	74.1	15.8	64.8	12.8	
-5.0	-5.6	88.4	88.4	23.6	79.6	19.2	70.7	15.5	61.9	12.6	
-7.0	-7.6	83.9	83.9	23.2	75.5	18.8	67.1	15.2	58.7	12.4	
-10	-10.5	77.2	77.2	22.6	69.5	18.3	61.7	14.8	54.0	12.0	
-14.5	-15.0	66.4	66.4	21.7	59.8	17.6	53.1	14.2	46.5	11.5	

Outdoor Unit Dry-Bulb (°C)		Outdoor Unit Wet-Bulb (°C)	Outdoor Unit 100 % Heating Capacity (kW)	Compressor + Outdoor Fan Power consumption (kW)							
				60 %		50 %		40 %		30 %	
				TC (kW)	PI (kW)	TC (kW)	PI (kW)	TC (kW)	PI (kW)	TC (kW)	PI (kW)
15.0	13.7	113.0	67.8	10.4	56.5	8.64	45.2	7.09	33.9	5.64	
13.0	11.8	113.0	67.8	10.6	56.5	8.75	45.2	7.16	33.9	5.68	
11.0	9.8	113.0	67.8	10.8	56.5	8.88	45.2	7.24	33.9	5.73	
9.0	7.9	113.0	67.8	11.0	56.5	9.03	45.2	7.33	33.9	5.78	
7.0	6.0	113.0	67.8	11.3	56.5	9.19	45.2	7.43	33.9	5.84	
5.0	4.1	109.2	65.5	11.1	54.6	9.05	43.7	7.31	32.7	5.76	
3.0	2.2	105.2	63.1	11.0	52.6	8.91	42.1	7.20	31.6	5.67	
0.0	-0.7	99.1	59.5	10.7	49.6	8.70	39.7	7.03	29.7	5.53	
-3.0	-3.7	92.6	55.6	10.4	46.3	8.48	37.0	6.85	27.8	5.39	
-5.0	-5.6	88.4	53.0	10.2	44.2	8.34	35.4	6.74	26.5	5.30	
-7.0	-7.6	83.9	50.3	10.1	41.9	8.19	33.6	6.62	25.2	5.21	
-10	-10.5	77.2	46.3	9.80	38.6	7.98	30.9	6.45	23.2	5.07	
-14.5	-15.0	66.4	39.9	9.40	33.2	7.65	26.6	6.18	19.9	4.86	

TC : Total Capacity PI : Power Input
Indoor air temperature conditions : 20.0 °C dry-bulb



MMY-AP3824HT8P-E, AP3824T8P-E (38HP, 106.5 kW system)

Cooling

Outdoor Unit Dry-Bulb (°C)		Outdoor Unit 100 % Cooling Capacity (kW)	Compressor + Outdoor Fan Power consumption (kW)							
			100 %		90 %		80 %		70 %	
			TC (kW)	PI (kW)	TC (kW)	PI (kW)	TC (kW)	PI (kW)	TC (kW)	PI (kW)
40	99.1	99.1	29.9	89.2	24.6	79.3	19.9	69.4	15.9	
39	100.7	100.7	29.5	90.6	24.2	80.6	19.6	70.5	15.7	
37	103.7	103.7	28.6	93.3	23.5	83.0	19.0	72.6	15.2	
35	106.5	106.5	27.7	95.9	22.7	85.2	18.4	74.6	14.7	
33	106.5	106.5	25.6	95.9	21.1	85.2	17.1	74.6	13.7	
31	106.5	106.5	23.7	95.9	19.6	85.2	15.9	74.6	12.8	
30	106.5	106.5	22.9	95.9	18.9	85.2	15.4	74.6	12.4	
29	106.5	106.5	22.1	95.9	18.2	85.2	14.9	74.6	12.0	
27	106.5	106.5	20.6	95.9	17.0	85.2	13.9	74.6	11.2	
25	106.5	106.5	19.2	95.9	15.9	85.2	13.0	74.6	10.5	
23	106.5	106.5	18.0	95.9	14.9	85.2	12.2	74.6	9.9	
21	106.5	106.5	17.6	95.9	14.6	85.2	12.0	74.6	9.73	
20	106.5	106.5	17.4	95.9	14.4	85.2	11.9	74.6	9.65	
19	106.5	106.5	17.2	95.9	14.3	85.2	11.8	74.6	9.58	
17	106.5	106.5	17.0	95.9	14.1	85.2	11.6	74.6	9.45	
15	106.5	106.5	16.7	95.9	13.9	85.2	11.4	74.6	9.35	

Outdoor Unit Dry-Bulb (°C)		Outdoor Unit 100 % Cooling Capacity (kW)	Compressor + Outdoor Fan Power consumption (kW)							
			60 %		50 %		40 %		30 %	
			TC (kW)	PI (kW)	TC (kW)	PI (kW)	TC (kW)	PI (kW)	TC (kW)	PI (kW)
40	99.1	59.5	12.6	49.6	9.9	39.6	7.93	29.7	6.59	
39	100.7	60.4	12.4	50.3	9.78	40.3	7.81	30.2	6.49	
37	103.7	62.2	12.0	51.9	9.49	41.5	7.57	31.1	6.30	
35	106.5	63.9	11.7	53.3	9.19	42.6	7.34	32.0	6.10	
33	106.5	63.9	10.9	53.3	8.64	42.6	6.96	32.0	5.83	
31	106.5	63.9	10.2	53.3	8.15	42.6	6.60	32.0	5.58	
30	106.5	63.9	9.9	53.3	7.92	42.6	6.44	32.0	5.46	
29	106.5	63.9	9.60	53.3	7.69	42.6	6.27	32.0	5.34	
27	106.5	63.9	9.03	53.3	7.27	42.6	5.96	32.0	5.10	
25	106.5	63.9	8.49	53.3	6.87	42.6	5.66	32.0	4.87	
23	106.5	63.9	8.00	53.3	6.49	42.6	5.37	32.0	4.65	
21	106.5	63.9	7.88	53.3	6.41	42.6	5.33	32.0	4.63	
20	106.5	63.9	7.82	53.3	6.38	42.6	5.31	32.0	4.62	
19	106.5	63.9	7.77	53.3	6.34	42.6	5.29	32.0	4.61	
17	106.5	63.9	7.69	53.3	6.29	42.6	5.26	32.0	4.60	
15	106.5	63.9	7.61	53.3	6.24	42.6	5.23	32.0	4.59	

TC : Total Capacity PI : Power Input
Indoor air temperature conditions : 27.0 °C dry-bulb / 19.0 °C wet bulb

Heating

Outdoor Unit Dry-Bulb (°C)		Outdoor Unit Wet-Bulb (°C)	Outdoor Unit 100 % Heating Capacity (kW)	Compressor + Outdoor Fan Power consumption (kW)							
				100 %		90 %		80 %		70 %	
				TC (kW)	PI (kW)	TC (kW)	PI (kW)	TC (kW)	PI (kW)	TC (kW)	PI (kW)
15.0	13.7	119.5	119.5	23.3	107.6	19.4	95.6	16.1	83.7	13.4	
13.0	11.8	119.5	119.5	24.2	107.6	20.0	95.6	16.5	83.7	13.7	
11.0	9.8	119.5	119.5	25.4	107.6	20.8	95.6	17.1	83.7	14.1	
9.0	7.9	119.5	119.5	26.6	107.6	21.7	95.6	17.7	83.7	14.5	
7.0	6.0	119.5	119.5	28.0	107.6	22.7	95.6	18.4	83.7	14.9	
5.0	4.1	115.4	115.4	27.6	103.9	22.4	92.4	18.1	80.8	14.7	
3.0	2.2	111.3	111.3	27.2	100.2	22.0	89.0	17.8	77.9	14.5	
0.0	-0.7	104.8	104.8	26.5	94.4	21.5	83.9	17.4	73.4	14.1	
-3.0	-3.7	98.0	98.0	25.9	88.2	20.9	78.4	17.0	68.6	13.8	
-5.0	-5.6	93.5	93.5	25.4	84.1	20.6	74.8	16.7	65.4	13.5	
-7.0	-7.6	88.7	88.7	25.0	79.8	20.2	71.0	16.4	62.1	13.3	
-10	-10.5	81.6	81.6	24.3	73.5	19.7	65.3	16.0	57.1	13.0	
-14.5	-15.0	70.2	70.2	23.3	63.2	18.9	56.2	15.3	49.2	12.4	

Outdoor Unit Dry-Bulb (°C)		Outdoor Unit Wet-Bulb (°C)	Outdoor Unit 100 % Heating Capacity (kW)	Compressor + Outdoor Fan Power consumption (kW)							
				60 %		50 %		40 %		30 %	
				TC (kW)	PI (kW)	TC (kW)	PI (kW)	TC (kW)	PI (kW)	TC (kW)	PI (kW)
15.0	13.7	119.5	71.7	11.2	59.8	9.30	47.8	7.63	35.9	6.06	
13.0	11.8	119.5	71.7	11.4	59.8	9.41	47.8	7.70	35.9	6.11	
11.0	9.8	119.5	71.7	11.6	59.8	9.55	47.8	7.79	35.9	6.16	
9.0	7.9	119.5	71.7	11.9	59.8	9.71	47.8	7.88	35.9	6.22	
7.0	6.0	119.5	71.7	12.1	59.8	9.89	47.8	7.99	35.9	6.29	
5.0	4.1	115.4	69.3	12.0	57.7	9.74	46.2	7.87	34.6	6.19	
3.0	2.2	111.3	66.8	11.8	55.7	9.59	44.5	7.75	33.4	6.10	
0.0	-0.7	104.8	62.9	11.5	52.4	9.36	41.9	7.56	31.5	5.95	
-3.0	-3.7	98.0	58.8	11.2	49.0	9.12	39.2	7.37	29.4	5.80	
-5.0	-5.6	93.5	56.1	11.0	46.7	8.97	37.4	7.25	28.0	5.70	
-7.0	-7.6	88.7	53.2	10.8	44.4	8.81	35.5	7.12	26.6	5.60	
-10	-10.5	81.6	49.0	10.5	40.8	8.58	32.6	6.93	24.5	5.46	
-14.5	-15.0	70.2	42.1	10.1	35.1	8.23	28.1	6.65	21.1	5.23	

TC : Total Capacity PI : Power Input
Indoor air temperature conditions : 20.0 °C dry-bulb



MMY-AP4024HT8P-E, AP4024T8P-E (40HP, 112 kW system)

Cooling

Outdoor Unit Dry-Bulb (°C)		Outdoor Unit 100 % Cooling Capacity (kW)	Compressor + Outdoor Fan Power consumption (kW)							
			100 %		90 %		80 %		70 %	
			TC (kW)	PI (kW)	TC (kW)	PI (kW)	TC (kW)	PI (kW)	TC (kW)	PI (kW)
40	104.2	104.2	32.0	93.8	26.3	83.4	21.3	73.0	17.1	
39	105.9	105.9	31.5	95.3	25.9	84.7	21.0	74.1	16.8	
37	109.1	109.1	30.6	98.2	25.1	87.2	20.4	76.3	16.3	
35	112.0	112.0	29.6	100.8	24.4	89.6	19.7	78.4	15.8	
33	112.0	112.0	27.4	100.8	22.6	89.6	18.3	78.4	14.7	
31	112.0	112.0	25.4	100.8	21.0	89.6	17.1	78.4	13.7	
30	112.0	112.0	24.5	100.8	20.2	89.6	16.5	78.4	13.3	
29	112.0	112.0	23.6	100.8	19.5	89.6	15.9	78.4	12.8	
27	112.0	112.0	22.0	100.8	18.2	89.6	14.9	78.4	12.0	
25	112.0	112.0	20.6	100.8	17.0	89.6	13.9	78.4	11.3	
23	112.0	112.0	19.2	100.8	15.9	89.6	13.1	78.4	10.6	
21	112.0	112.0	18.8	100.8	15.6	89.6	12.8	78.4	10.4	
20	112.0	112.0	18.6	100.8	15.5	89.6	12.7	78.4	10.3	
19	112.0	112.0	18.5	100.8	15.3	89.6	12.6	78.4	10.3	
17	112.0	112.0	18.2	100.8	15.1	89.6	12.4	78.4	10.1	
15	112.0	112.0	17.9	100.8	14.9	89.6	12.3	78.4	10.0	

Outdoor Unit Dry-Bulb (°C)		Outdoor Unit 100 % Cooling Capacity (kW)	Compressor + Outdoor Fan Power consumption (kW)							
			60 %		50 %		40 %		30 %	
			TC (kW)	PI (kW)	TC (kW)	PI (kW)	TC (kW)	PI (kW)	TC (kW)	PI (kW)
40	104.2	62.5	13.5	52.1	10.6	41.7	8.49	31.3	7.06	
39	105.9	63.5	13.3	52.9	10.5	42.4	8.36	31.8	6.95	
37	109.1	65.4	12.9	54.5	10.2	43.6	8.11	32.7	6.74	
35	112.0	67.2	12.5	56.0	9.84	44.8	7.86	33.6	6.53	
33	112.0	67.2	11.7	56.0	9.26	44.8	7.45	33.6	6.25	
31	112.0	67.2	10.9	56.0	8.73	44.8	7.07	33.6	5.98	
30	112.0	67.2	10.6	56.0	8.48	44.8	6.89	33.6	5.85	
29	112.0	67.2	10.3	56.0	8.24	44.8	6.72	33.6	5.72	
27	112.0	67.2	9.7	56.0	7.78	44.8	6.38	33.6	5.46	
25	112.0	67.2	9.1	56.0	7.35	44.8	6.06	33.6	5.22	
23	112.0	67.2	8.6	56.0	6.95	44.8	5.75	33.6	4.97	
21	112.0	67.2	8.4	56.0	6.86	44.8	5.70	33.6	4.95	
20	112.0	67.2	8.4	56.0	6.83	44.8	5.68	33.6	4.95	
19	112.0	67.2	8.3	56.0	6.79	44.8	5.66	33.6	4.94	
17	112.0	67.2	8.2	56.0	6.73	44.8	5.63	33.6	4.92	
15	112.0	67.2	8.2	56.0	6.68	44.8	5.60	33.6	4.91	

TC : Total Capacity PI : Power Input
Indoor air temperature conditions : 27.0 °C dry-bulb / 19.0 °C wet bulb

Heating

Outdoor Unit Dry-Bulb (°C) Wet-Bulb (°C)			Outdoor Unit 100 % Heating Capacity (kW)	Compressor + Outdoor Fan Power consumption (kW)							
				100 %		90 %		80 %		70 %	
				TC (kW)	PI (kW)	TC (kW)	PI (kW)	TC (kW)	PI (kW)	TC (kW)	PI (kW)
15.0	13.7	127.0	127.0	25.3	114.3	21.0	101.6	17.5	88.9	14.6	
13.0	11.8	127.0	127.0	26.3	114.3	21.7	101.6	18.0	88.9	14.9	
11.0	9.8	127.0	127.0	27.5	114.3	22.6	101.6	18.5	88.9	15.3	
9.0	7.9	127.0	127.0	28.9	114.3	23.5	101.6	19.2	88.9	15.7	
7.0	6.0	127.0	127.0	30.4	114.3	24.6	101.6	20.0	88.9	16.2	
5.0	4.1	122.7	122.7	30.0	110.4	24.3	98.1	19.7	85.9	16.0	
3.0	2.2	118.3	118.3	29.5	106.5	23.9	94.6	19.4	82.8	15.7	
0.0	-0.7	111.4	111.4	28.8	100.3	23.3	89.1	18.9	78.0	15.3	
-3.0	-3.7	104.1	104.1	28.1	93.7	22.7	83.3	18.4	72.9	14.9	
-5.0	-5.6	99.4	99.4	27.6	89.4	22.4	79.5	18.1	69.5	14.7	
-7.0	-7.6	94.3	94.3	27.1	84.8	22.0	75.4	17.8	66.0	14.4	
-10	-10.5	86.7	86.7	26.4	78.1	21.4	69.4	17.3	60.7	14.1	
-14.5	-15.0	74.6	74.6	25.3	67.2	20.5	59.7	16.6	52.3	13.5	

Outdoor Unit Dry-Bulb (°C) Wet-Bulb (°C)			Outdoor Unit 100 % Heating Capacity (kW)	Compressor + Outdoor Fan Power consumption (kW)							
				60 %		50 %		40 %		30 %	
				TC (kW)	PI (kW)	TC (kW)	PI (kW)	TC (kW)	PI (kW)	TC (kW)	PI (kW)
15.0	13.7	127.0	76.2	12.1	63.5	10.1	50.8	8.28	38.1	6.58	
13.0	11.8	127.0	76.2	12.3	63.5	10.2	50.8	8.36	38.1	6.63	
11.0	9.8	127.0	76.2	12.6	63.5	10.4	50.8	8.45	38.1	6.69	
9.0	7.9	127.0	76.2	12.9	63.5	10.5	50.8	8.55	38.1	6.75	
7.0	6.0	127.0	76.2	13.2	63.5	10.7	50.8	8.67	38.1	6.82	
5.0	4.1	122.7	73.6	13.0	61.3	10.6	49.1	8.54	36.8	6.72	
3.0	2.2	118.3	71.0	12.8	59.1	10.4	47.3	8.41	35.5	6.62	
0.0	-0.7	111.4	66.8	12.5	55.7	10.2	44.6	8.20	33.4	6.46	
-3.0	-3.7	104.1	62.5	12.2	52.0	9.90	41.6	8.00	31.2	6.29	
-5.0	-5.6	99.4	59.6	12.0	49.7	9.74	39.7	7.87	29.8	6.19	
-7.0	-7.6	94.3	56.6	11.7	47.1	9.56	37.7	7.73	28.3	6.08	
-10	-10.5	86.7	52.0	11.4	43.4	9.31	34.7	7.53	26.0	5.92	
-14.5	-15.0	74.6	44.8	11.0	37.3	8.93	29.9	7.21	22.4	5.68	

TC : Total Capacity PI : Power Input
Indoor air temperature conditions : 20.0 °C dry-bulb



MMY-AP4224HT8P-E, AP4224T8P-E (42HP, 118 kW system)

Cooling

Outdoor Unit Dry-Bulb (°C)		Outdoor Unit 100 % Cooling Capacity (kW)	Compressor + Outdoor Fan Power consumption (kW)							
			100 %		90 %		80 %		70 %	
			TC (kW)	PI (kW)	TC (kW)	PI (kW)	TC (kW)	PI (kW)	TC (kW)	PI (kW)
40	109.8	109.8	34.6	98.8	28.4	87.8	23.0	76.9	18.3	
39	111.6	111.6	34.1	100.4	28.0	89.3	22.6	78.1	18.0	
37	114.9	114.9	33.1	103.4	27.1	91.9	21.9	80.4	17.5	
35	118.0	118.0	32.0	106.2	26.3	94.4	21.2	82.6	17.0	
33	118.0	118.0	29.6	106.2	24.3	94.4	19.7	82.6	15.8	
31	118.0	118.0	27.4	106.2	22.6	94.4	18.3	82.6	14.7	
30	118.0	118.0	26.5	106.2	21.8	94.4	17.7	82.6	14.2	
29	118.0	118.0	25.5	106.2	21.0	94.4	17.1	82.6	13.8	
27	118.0	118.0	23.8	106.2	19.6	94.4	16.0	82.6	12.9	
25	118.0	118.0	22.2	106.2	18.3	94.4	15.0	82.6	12.1	
23	118.0	118.0	20.7	106.2	17.2	94.4	14.0	82.6	11.4	
21	118.0	118.0	20.3	106.2	16.8	94.4	13.8	82.6	11.2	
20	118.0	118.0	20.1	106.2	16.6	94.4	13.6	82.6	11.1	
19	118.0	118.0	19.9	106.2	16.5	94.4	13.5	82.6	11.0	
17	118.0	118.0	19.6	106.2	16.2	94.4	13.3	82.6	10.9	
15	118.0	118.0	19.3	106.2	16.0	94.4	13.2	82.6	10.7	

Outdoor Unit Dry-Bulb (°C)		Outdoor Unit 100 % Cooling Capacity (kW)	Compressor + Outdoor Fan Power consumption (kW)							
			60 %		50 %		40 %		30 %	
			TC (kW)	PI (kW)	TC (kW)	PI (kW)	TC (kW)	PI (kW)	TC (kW)	PI (kW)
40	109.8	65.9	14.5	54.9	11.4	43.9	9.09	32.9	7.56	
39	111.6	66.9	14.2	55.8	11.2	44.6	8.96	33.5	7.45	
37	114.9	68.9	13.8	57.5	10.9	46.0	8.68	34.5	7.22	
35	118.0	70.8	13.4	59.0	10.54	47.2	8.41	35.4	7.00	
33	118.0	70.8	12.5	59.0	9.91	47.2	7.98	35.4	6.70	
31	118.0	70.8	11.7	59.0	9.34	47.2	7.57	35.4	6.41	
30	118.0	70.8	11.4	59.0	9.08	47.2	7.38	35.4	6.27	
29	118.0	70.8	11.0	59.0	8.82	47.2	7.19	35.4	6.13	
27	118.0	70.8	10.4	59.0	8.33	47.2	6.83	35.4	5.86	
25	118.0	70.8	9.75	59.0	7.87	47.2	6.49	35.4	5.59	
23	118.0	70.8	9.17	59.0	7.44	47.2	6.16	35.4	5.33	
21	118.0	70.8	9.04	59.0	7.35	47.2	6.11	35.4	5.31	
20	118.0	70.8	8.98	59.0	7.31	47.2	6.09	35.4	5.30	
19	118.0	70.8	8.92	59.0	7.27	47.2	6.07	35.4	5.29	
17	118.0	70.8	8.82	59.0	7.21	47.2	6.03	35.4	5.28	
15	118.0	70.8	8.73	59.0	7.15	47.2	6.00	35.4	5.27	

TC : Total Capacity PI : Power Input
Indoor air temperature conditions : 27.0 °C dry-bulb / 19.0 °C wet bulb

Heating

Outdoor Unit Dry-Bulb (°C)		Outdoor Unit Wet-Bulb (°C)	Outdoor Unit 100 % Heating Capacity (kW)	Compressor + Outdoor Fan Power consumption (kW)							
				100 %		90 %		80 %		70 %	
				TC (kW)	PI (kW)	TC (kW)	PI (kW)	TC (kW)	PI (kW)	TC (kW)	PI (kW)
15.0	13.7	132.0	132.0	27.2	118.8	22.6	105.6	18.7	92.4	15.6	
13.0	11.8	132.0	132.0	28.3	118.8	23.4	105.6	19.3	92.4	15.9	
11.0	9.8	132.0	132.0	29.6	118.8	24.3	105.6	19.9	92.4	16.3	
9.0	7.9	132.0	132.0	31.0	118.8	25.3	105.6	20.6	92.4	16.8	
7.0	6.0	132.0	132.0	32.7	118.8	26.5	105.6	21.5	92.4	17.4	
5.0	4.1	127.5	127.5	32.2	114.8	26.1	102.0	21.1	89.3	17.1	
3.0	2.2	122.9	122.9	31.7	110.7	25.7	98.4	20.8	86.1	16.8	
0.0	-0.7	115.8	115.8	30.9	104.2	25.1	92.6	20.3	81.1	16.4	
-3.0	-3.7	108.2	108.2	30.2	97.4	24.5	86.6	19.8	75.7	16.0	
-5.0	-5.6	103.3	103.3	29.7	92.9	24.0	82.6	19.5	72.3	15.8	
-7.0	-7.6	98.0	98.0	29.1	88.2	23.6	78.4	19.1	68.6	15.5	
-10	-10.5	90.1	90.1	28.4	81.1	23.0	72.1	18.6	63.1	15.1	
-14.5	-15.0	77.6	77.6	27.2	69.8	22.1	62.1	17.9	54.3	14.5	

Outdoor Unit Dry-Bulb (°C)		Outdoor Unit Wet-Bulb (°C)	Outdoor Unit 100 % Heating Capacity (kW)	Compressor + Outdoor Fan Power consumption (kW)							
				60 %		50 %		40 %		30 %	
				TC (kW)	PI (kW)	TC (kW)	PI (kW)	TC (kW)	PI (kW)	TC (kW)	PI (kW)
15.0	13.7	132.0	79.2	12.9	66.0	10.7	52.8	8.84	39.6	7.12	
13.0	11.8	132.0	79.2	13.2	66.0	10.9	52.8	8.92	39.6	7.16	
11.0	9.8	132.0	79.2	13.4	66.0	11.0	52.8	9.01	39.6	7.21	
9.0	7.9	132.0	79.2	13.7	66.0	11.2	52.8	9.11	39.6	7.27	
7.0	6.0	132.0	79.2	14.1	66.0	11.4	52.8	9.24	39.6	7.33	
5.0	4.1	127.5	76.5	13.9	63.8	11.3	51.0	9.09	38.3	7.22	
3.0	2.2	122.9	73.8	13.7	61.5	11.1	49.2	8.95	36.9	7.11	
0.0	-0.7	115.8	69.5	13.3	57.9	10.8	46.3	8.74	34.7	6.94	
-3.0	-3.7	108.2	64.9	13.0	54.1	10.54	43.3	8.52	32.5	6.76	
-5.0	-5.6	103.3	62.0	12.8	51.6	10.37	41.3	8.38	31.0	6.65	
-7.0	-7.6	98.0	58.8	12.6	49.0	10.19	39.2	8.23	29.4	6.53	
-10	-10.5	90.1	54.1	12.2	45.1	9.92	36.1	8.02	27.0	6.36	
-14.5	-15.0	77.6	46.6	11.7	38.8	9.51	31.0	7.68	23.3	6.10	

TC : Total Capacity PI : Power Input
Indoor air temperature conditions : 20.0 °C dry-bulb



MMY-AP4424HT8P-E, AP4424T8P-E (44HP, 123.5 kW system)

Cooling

Outdoor Unit Dry-Bulb (°C)		Outdoor Unit 100 % Cooling Capacity (kW)	Compressor + Outdoor Fan Power consumption (kW)							
			100 %		90 %		80 %		70 %	
			TC (kW)	PI (kW)	TC (kW)	PI (kW)	TC (kW)	PI (kW)	TC (kW)	PI (kW)
40	114.9	114.9	36.9	103.4	30.2	91.9	24.4	80.4	19.5	
39	116.8	116.8	36.4	105.1	29.8	93.4	24.1	81.7	19.2	
37	120.3	120.3	35.3	108.2	28.9	96.2	23.3	84.2	18.6	
35	123.5	123.5	34.2	111.2	28.0	98.8	22.6	86.5	18.0	
33	123.5	123.5	31.6	111.2	25.9	98.8	21.0	86.5	16.7	
31	123.5	123.5	29.3	111.2	24.1	98.8	19.5	86.5	15.6	
30	123.5	123.5	28.2	111.2	23.2	98.8	18.8	86.5	15.1	
29	123.5	123.5	27.2	111.2	22.4	98.8	18.2	86.5	14.6	
27	123.5	123.5	25.4	111.2	20.9	98.8	17.0	86.5	13.7	
25	123.5	123.5	23.7	111.2	19.5	98.8	15.9	86.5	12.8	
23	123.5	123.5	22.1	111.2	18.3	98.8	14.9	86.5	12.1	
21	123.5	123.5	21.6	111.2	17.9	98.8	14.6	86.5	11.8	
20	123.5	123.5	21.4	111.2	17.7	98.8	14.5	86.5	11.7	
19	123.5	123.5	21.2	111.2	17.6	98.8	14.4	86.5	11.7	
17	123.5	123.5	20.9	111.2	17.3	98.8	14.2	86.5	11.5	
15	123.5	123.5	20.6	111.2	17.0	98.8	14.0	86.5	11.4	

Outdoor Unit Dry-Bulb (°C)		Outdoor Unit 100 % Cooling Capacity (kW)	Compressor + Outdoor Fan Power consumption (kW)							
			60 %		50 %		40 %		30 %	
			TC (kW)	PI (kW)	TC (kW)	PI (kW)	TC (kW)	PI (kW)	TC (kW)	PI (kW)
40	114.9	69.0	15.3	57.5	12.0	46.0	9.59	34.5	7.99	
39	116.8	70.1	15.1	58.4	11.9	46.7	9.45	35.0	7.87	
37	120.3	72.2	14.6	60.1	11.5	48.1	9.16	36.1	7.63	
35	123.5	74.1	14.2	61.8	11.1	49.4	8.87	37.1	7.39	
33	123.5	74.1	13.2	61.8	10.5	49.4	8.41	37.1	7.08	
31	123.5	74.1	12.4	61.8	9.87	49.4	7.99	37.1	6.77	
30	123.5	74.1	12.0	61.8	9.58	49.4	7.78	37.1	6.63	
29	123.5	74.1	11.7	61.8	9.31	49.4	7.59	37.1	6.48	
27	123.5	74.1	11.0	61.8	8.79	49.4	7.21	37.1	6.20	
25	123.5	74.1	10.3	61.8	8.31	49.4	6.85	37.1	5.92	
23	123.5	74.1	9.70	61.8	7.85	49.4	6.50	37.1	5.64	
21	123.5	74.1	9.55	61.8	7.76	49.4	6.44	37.1	5.62	
20	123.5	74.1	9.49	61.8	7.71	49.4	6.42	37.1	5.61	
19	123.5	74.1	9.43	61.8	7.68	49.4	6.40	37.1	5.60	
17	123.5	74.1	9.32	61.8	7.61	49.4	6.36	37.1	5.59	
15	123.5	74.1	9.23	61.8	7.55	49.4	6.33	37.1	5.58	

TC : Total Capacity PI : Power Input
Indoor air temperature conditions : 27.0 °C dry-bulb / 19.0 °C wet bulb

Heating

Outdoor Unit Dry-Bulb (°C) Wet-Bulb (°C)			Outdoor Unit 100 % Heating Capacity (kW)	Compressor + Outdoor Fan Power consumption (kW)							
				100 %		90 %		80 %		70 %	
				TC (kW)	PI (kW)	TC (kW)	PI (kW)	TC (kW)	PI (kW)	TC (kW)	PI (kW)
15.0	13.7	138.0	138.0	29.5	124.2	24.4	110.4	20.2	96.6	16.8	
13.0	11.8	138.0	138.0	30.7	124.2	25.3	110.4	20.8	96.6	17.2	
11.0	9.8	138.0	138.0	32.1	124.2	26.3	110.4	21.5	96.6	17.6	
9.0	7.9	138.0	138.0	33.6	124.2	27.4	110.4	22.3	96.6	18.2	
7.0	6.0	138.0	138.0	35.4	124.2	28.7	110.4	23.2	96.6	18.8	
5.0	4.1	133.3	133.3	34.9	120.0	28.3	106.6	22.9	93.3	18.5	
3.0	2.2	128.5	128.5	34.3	115.7	27.8	102.8	22.5	90.0	18.2	
0.0	-0.7	121.1	121.1	33.5	109.0	27.2	96.9	22.0	84.7	17.8	
-3.0	-3.7	113.1	113.1	32.6	101.8	26.5	90.5	21.4	79.2	17.3	
-5.0	-5.6	108.0	108.0	32.1	97.2	26.1	86.4	21.1	75.6	17.0	
-7.0	-7.6	102.4	102.4	31.5	92.2	25.6	82.0	20.7	71.7	16.7	
-10	-10.5	94.2	94.2	30.7	84.8	24.9	75.4	20.2	66.0	16.3	
-14.5	-15.0	81.1	81.1	29.4	73.0	23.9	64.9	19.3	56.8	15.6	

Outdoor Unit Dry-Bulb (°C) Wet-Bulb (°C)			Outdoor Unit 100 % Heating Capacity (kW)	Compressor + Outdoor Fan Power consumption (kW)							
				60 %		50 %		40 %		30 %	
				TC (kW)	PI (kW)	TC (kW)	PI (kW)	TC (kW)	PI (kW)	TC (kW)	PI (kW)
15.0	13.7	138.0	82.8	13.9	69.0	11.5	55.2	9.51	41.4	7.76	
13.0	11.8	138.0	82.8	14.1	69.0	11.7	55.2	9.58	41.4	7.79	
11.0	9.8	138.0	82.8	14.4	69.0	11.8	55.2	9.68	41.4	7.83	
9.0	7.9	138.0	82.8	14.8	69.0	12.0	55.2	9.78	41.4	7.88	
7.0	6.0	138.0	82.8	15.2	69.0	12.3	55.2	9.91	41.4	7.94	
5.0	4.1	133.3	80.0	14.9	66.7	12.1	53.3	9.76	40.0	7.81	
3.0	2.2	128.5	77.1	14.7	64.3	11.9	51.4	9.61	38.6	7.69	
0.0	-0.7	121.1	72.6	14.3	60.5	11.6	48.4	9.38	36.3	7.51	
-3.0	-3.7	113.1	67.9	14.0	56.6	11.3	45.2	9.14	33.9	7.32	
-5.0	-5.6	108.0	64.8	13.8	54.0	11.1	43.2	8.99	32.4	7.20	
-7.0	-7.6	102.4	61.5	13.5	51.2	10.9	41.0	8.83	30.7	7.07	
-10	-10.5	94.2	56.5	13.2	47.1	10.6	37.7	8.60	28.3	6.89	
-14.5	-15.0	81.1	48.7	12.6	40.6	10.2	32.4	8.24	24.3	6.60	

TC : Total Capacity PI : Power Input
Indoor air temperature conditions : 20.0 °C dry-bulb



MMY-AP4624HT8P-E, AP4624T8P-E (46HP, 130 kW system)

Cooling

Outdoor Unit Dry-Bulb (°C)		Outdoor Unit 100 % Cooling Capacity (kW)	Compressor + Outdoor Fan Power consumption (kW)							
			100 %		90 %		80 %		70 %	
			TC (kW)	PI (kW)	TC (kW)	PI (kW)	TC (kW)	PI (kW)	TC (kW)	PI (kW)
40	121.0	121.0	39.8	108.9	32.5	96.8	26.2	84.7	20.8	
39	122.9	122.9	39.2	110.6	32.1	98.3	25.8	86.0	20.5	
37	126.6	126.6	38.1	113.9	31.1	101.3	25.0	88.6	19.9	
35	130.0	130.0	36.9	117.0	30.1	104.0	24.2	91.0	19.3	
33	130.0	130.0	34.0	117.0	27.8	104.0	22.5	91.0	17.9	
31	130.0	130.0	31.5	117.0	25.8	104.0	20.9	91.0	16.7	
30	130.0	130.0	30.4	117.0	24.9	104.0	20.2	91.0	16.2	
29	130.0	130.0	29.3	117.0	24.0	104.0	19.5	91.0	15.6	
27	130.0	130.0	27.3	117.0	22.4	104.0	18.2	91.0	14.6	
25	130.0	130.0	25.5	117.0	20.9	104.0	17.0	91.0	13.7	
23	130.0	130.0	23.8	117.0	19.6	104.0	16.0	91.0	12.9	
21	130.0	130.0	23.2	117.0	19.2	104.0	15.6	91.0	12.7	
20	130.0	130.0	23.0	117.0	19.0	104.0	15.5	91.0	12.6	
19	130.0	130.0	22.8	117.0	18.8	104.0	15.4	91.0	12.5	
17	130.0	130.0	22.4	117.0	18.5	104.0	15.1	91.0	12.3	
15	130.0	130.0	22.1	117.0	18.3	104.0	15.0	91.0	12.2	

Outdoor Unit Dry-Bulb (°C)		Outdoor Unit 100 % Cooling Capacity (kW)	Compressor + Outdoor Fan Power consumption (kW)							
			60 %		50 %		40 %		30 %	
			TC (kW)	PI (kW)	TC (kW)	PI (kW)	TC (kW)	PI (kW)	TC (kW)	PI (kW)
40	121.0	72.6	16.4	60.5	12.9	48.4	10.3	36.3	8.55	
39	122.9	73.8	16.1	61.5	12.7	49.2	10.1	36.9	8.43	
37	126.6	76.0	15.7	63.3	12.3	50.6	9.80	38.0	8.17	
35	130.0	78.0	15.2	65.0	11.9	52.0	9.50	39.0	7.91	
33	130.0	78.0	14.2	65.0	11.2	52.0	9.01	39.0	7.58	
31	130.0	78.0	13.3	65.0	10.6	52.0	8.55	39.0	7.25	
30	130.0	78.0	12.9	65.0	10.3	52.0	8.33	39.0	7.09	
29	130.0	78.0	12.5	65.0	9.96	52.0	8.12	39.0	6.94	
27	130.0	78.0	11.7	65.0	9.41	52.0	7.72	39.0	6.63	
25	130.0	78.0	11.0	65.0	8.89	52.0	7.33	39.0	6.33	
23	130.0	78.0	10.4	65.0	8.40	52.0	6.96	39.0	6.04	
21	130.0	78.0	10.2	65.0	8.30	52.0	6.90	39.0	6.02	
20	130.0	78.0	10.1	65.0	8.25	52.0	6.88	39.0	6.01	
19	130.0	78.0	10.1	65.0	8.21	52.0	6.85	39.0	6.00	
17	130.0	78.0	9.97	65.0	8.14	52.0	6.81	39.0	5.98	
15	130.0	78.0	9.87	65.0	8.08	52.0	6.78	39.0	5.97	

TC : Total Capacity PI : Power Input
Indoor air temperature conditions : 27.0 °C dry-bulb / 19.0 °C wet bulb

Heating

Outdoor Unit Dry-Bulb (°C) Wet-Bulb (°C) Heating Capacity (kW)			Compressor + Outdoor Fan Power consumption (kW)							
			100 %		90 %		80 %		70 %	
			TC (kW)	PI (kW)	TC (kW)	PI (kW)	TC (kW)	PI (kW)	TC (kW)	PI (kW)
15.0	13.7	145.0	145.0	32.2	130.5	26.6	116.0	22.0	101.5	18.2
13.0	11.8	145.0	145.0	33.4	130.5	27.6	116.0	22.6	101.5	18.6
11.0	9.8	145.0	145.0	35.0	130.5	28.7	116.0	23.4	101.5	19.1
9.0	7.9	145.0	145.0	36.6	130.5	29.9	116.0	24.3	101.5	19.7
7.0	6.0	145.0	145.0	38.6	130.5	31.3	116.0	25.3	101.5	20.4
5.0	4.1	140.1	140.1	38.0	126.1	30.8	112.1	24.9	98.1	20.1
3.0	2.2	135.1	135.1	37.4	121.5	30.4	108.0	24.5	94.5	19.8
0.0	-0.7	127.2	127.2	36.5	114.5	29.6	101.8	23.9	89.0	19.3
-3.0	-3.7	118.9	118.9	35.6	107.0	28.9	95.1	23.3	83.2	18.8
-5.0	-5.6	113.4	113.4	35.0	102.1	28.4	90.8	23.0	79.4	18.5
-7.0	-7.6	107.6	107.6	34.4	96.9	27.9	86.1	22.6	75.3	18.2
-10	-10.5	99.0	99.0	33.5	89.1	27.2	79.2	22.0	69.3	17.7
-14.5	-15.0	85.2	85.2	32.1	76.7	26.1	68.2	21.1	59.7	17.0

Outdoor Unit Dry-Bulb (°C) Wet-Bulb (°C) Heating Capacity (kW)			Compressor + Outdoor Fan Power consumption (kW)							
			60 %		50 %		40 %		30 %	
			TC (kW)	PI (kW)	TC (kW)	PI (kW)	TC (kW)	PI (kW)	TC (kW)	PI (kW)
15.0	13.7	145.0	87.0	15.0	72.5	12.4	58.0	10.3	43.5	8.51
13.0	11.8	145.0	87.0	15.3	72.5	12.6	58.0	10.4	43.5	8.53
11.0	9.8	145.0	87.0	15.6	72.5	12.8	58.0	10.5	43.5	8.56
9.0	7.9	145.0	87.0	16.0	72.5	13.0	58.0	10.6	43.5	8.59
7.0	6.0	145.0	87.0	16.4	72.5	13.2	58.0	10.7	43.5	8.64
5.0	4.1	140.1	84.0	16.2	70.0	13.0	56.0	10.5	42.0	8.51
3.0	2.2	135.1	81.0	15.9	67.5	12.8	54.0	10.4	40.5	8.38
0.0	-0.7	127.2	76.3	15.5	63.6	12.5	50.9	10.1	38.2	8.18
-3.0	-3.7	118.9	71.3	15.1	59.4	12.2	47.5	9.87	35.7	7.97
-5.0	-5.6	113.4	68.1	14.9	56.7	12.0	45.4	9.70	34.0	7.84
-7.0	-7.6	107.6	64.6	14.6	53.8	11.8	43.1	9.53	32.3	7.70
-10	-10.5	99.0	59.4	14.2	49.5	11.5	39.6	9.28	29.7	7.50
-14.5	-15.0	85.2	51.1	13.7	42.6	11.0	34.1	8.90	25.6	7.19

TC : Total Capacity PI : Power Input
Indoor air temperature conditions : 20.0 °C dry-bulb



MMY-AP4824HT8P-E, AP4824T8P-E (48HP, 135 kW system)

Cooling

Outdoor Unit Dry-Bulb (°C)		Outdoor Unit 100 % Cooling Capacity (kW)	Compressor + Outdoor Fan Power consumption (kW)							
			100 %		90 %		80 %		70 %	
			TC (kW)	PI (kW)	TC (kW)	PI (kW)	TC (kW)	PI (kW)	TC (kW)	PI (kW)
40		125.6	41.9	113.1	34.1	100.5	27.4	87.9	21.7	
39		127.6	41.2	114.9	33.6	102.1	27.0	89.4	21.4	
37		131.5	40.0	118.3	32.6	105.2	26.2	92.0	20.8	
35		135.0	38.8	121.5	31.6	108.0	25.4	94.5	20.1	
33		135.0	35.8	121.5	29.2	108.0	23.5	94.5	18.7	
31		135.0	33.1	121.5	27.1	108.0	21.9	94.5	17.5	
30		135.0	31.9	121.5	26.1	108.0	21.1	94.5	16.9	
29		135.0	30.8	121.5	25.2	108.0	20.4	94.5	16.3	
27		135.0	28.6	121.5	23.5	108.0	19.0	94.5	15.3	
25		135.0	26.7	121.5	21.9	108.0	17.8	94.5	14.3	
23		135.0	24.9	121.5	20.5	108.0	16.7	94.5	13.4	
21		135.0	24.4	121.5	20.1	108.0	16.3	94.5	13.2	
20		135.0	24.1	121.5	19.9	108.0	16.2	94.5	13.1	
19		135.0	23.9	121.5	19.7	108.0	16.1	94.5	13.0	
17		135.0	23.5	121.5	19.4	108.0	15.8	94.5	12.8	
15		135.0	23.1	121.5	19.1	108.0	15.6	94.5	12.7	

Outdoor Unit Dry-Bulb (°C)		Outdoor Unit 100 % Cooling Capacity (kW)	Compressor + Outdoor Fan Power consumption (kW)							
			60 %		50 %		40 %		30 %	
			TC (kW)	PI (kW)	TC (kW)	PI (kW)	TC (kW)	PI (kW)	TC (kW)	PI (kW)
40		125.6	75.4	17.1	62.8	13.4	50.3	10.7	37.7	8.91
39		127.6	76.6	16.8	63.8	13.2	51.1	10.5	38.3	8.78
37		131.5	78.9	16.3	65.7	12.8	52.6	10.2	39.4	8.51
35		135.0	81.0	15.8	67.5	12.4	54.0	9.88	40.5	8.24
33		135.0	81.0	14.8	67.5	11.7	54.0	9.37	40.5	7.89
31		135.0	81.0	13.8	67.5	11.0	54.0	8.90	40.5	7.56
30		135.0	81.0	13.4	67.5	10.7	54.0	8.67	40.5	7.39
29		135.0	81.0	13.0	67.5	10.4	54.0	8.45	40.5	7.23
27		135.0	81.0	12.2	67.5	9.79	54.0	8.03	40.5	6.91
25		135.0	81.0	11.5	67.5	9.25	54.0	7.63	40.5	6.60
23		135.0	81.0	10.8	67.5	8.74	54.0	7.24	40.5	6.30
21		135.0	81.0	10.6	67.5	8.64	54.0	7.18	40.5	6.27
20		135.0	81.0	10.6	67.5	8.59	54.0	7.16	40.5	6.26
19		135.0	81.0	10.5	67.5	8.55	54.0	7.13	40.5	6.25
17		135.0	81.0	10.4	67.5	8.47	54.0	7.09	40.5	6.24
15		135.0	81.0	10.3	67.5	8.41	54.0	7.06	40.5	6.22

TC : Total Capacity PI : Power Input
Indoor air temperature conditions : 27.0 °C dry-bulb / 19.0 °C wet bulb

Heating

Outdoor Unit Dry-Bulb (°C) Wet-Bulb (°C)			Outdoor Unit 100 % Heating Capacity (kW)	Compressor + Outdoor Fan Power consumption (kW)							
				100 %		90 %		80 %		70 %	
				TC (kW)	PI (kW)	TC (kW)	PI (kW)	TC (kW)	PI (kW)	TC (kW)	PI (kW)
15.0	13.7	150.0	150.0	34.0	135.0	28.2	120.0	23.2	105.0	19.1	
13.0	11.8	150.0	150.0	35.4	135.0	29.2	120.0	23.9	105.0	19.6	
11.0	9.8	150.0	150.0	37.0	135.0	30.3	120.0	24.8	105.0	20.2	
9.0	7.9	150.0	150.0	38.8	135.0	31.6	120.0	25.7	105.0	20.8	
7.0	6.0	150.0	150.0	40.8	135.0	33.1	120.0	26.8	105.0	21.5	
5.0	4.1	144.9	144.9	40.2	130.4	32.6	115.9	26.4	101.4	21.2	
3.0	2.2	139.7	139.7	39.6	125.7	32.1	111.8	25.9	97.8	20.9	
0.0	-0.7	131.6	131.6	38.6	118.4	31.4	105.3	25.3	92.1	20.4	
-3.0	-3.7	123.0	123.0	37.6	110.7	30.6	98.4	24.7	86.1	19.8	
-5.0	-5.6	117.4	117.4	37.0	105.6	30.1	93.9	24.3	82.1	19.5	
-7.0	-7.6	111.3	111.3	36.4	100.2	29.5	89.1	23.9	77.9	19.2	
-10	-10.5	102.4	102.4	35.4	92.2	28.8	82.0	23.2	71.7	18.7	
-14.5	-15.0	88.2	88.2	33.9	79.3	27.6	70.5	22.3	61.7	17.9	

Outdoor Unit Dry-Bulb (°C) Wet-Bulb (°C)			Outdoor Unit 100 % Heating Capacity (kW)	Compressor + Outdoor Fan Power consumption (kW)							
				60 %		50 %		40 %		30 %	
				TC (kW)	PI (kW)	TC (kW)	PI (kW)	TC (kW)	PI (kW)	TC (kW)	PI (kW)
15.0	13.7	150.0	90.0	15.7	75.0	13.0	60.0	10.8	45.0	9.06	
13.0	11.8	150.0	90.0	16.0	75.0	13.2	60.0	10.9	45.0	9.06	
11.0	9.8	150.0	90.0	16.4	75.0	13.4	60.0	11.0	45.0	9.08	
9.0	7.9	150.0	90.0	16.8	75.0	13.6	60.0	11.1	45.0	9.10	
7.0	6.0	150.0	90.0	17.3	75.0	13.9	60.0	11.2	45.0	9.14	
5.0	4.1	144.9	86.9	17.0	72.5	13.7	58.0	11.0	43.5	9.00	
3.0	2.2	139.7	83.8	16.7	69.9	13.4	55.9	10.9	41.9	8.86	
0.0	-0.7	131.6	79.0	16.3	65.8	13.1	52.6	10.6	39.5	8.65	
-3.0	-3.7	123.0	73.8	15.9	61.5	12.8	49.2	10.3	36.9	8.43	
-5.0	-5.6	117.4	70.4	15.7	58.7	12.6	46.9	10.2	35.2	8.29	
-7.0	-7.6	111.3	66.8	15.4	55.7	12.4	44.5	10.0	33.4	8.14	
-10	-10.5	102.4	61.5	15.0	51.2	12.0	41.0	9.73	30.7	7.93	
-14.5	-15.0	88.2	52.9	14.4	44.1	11.5	35.3	9.33	26.4	7.60	

TC : Total Capacity PI : Power Input
Indoor air temperature conditions : 20.0 °C dry-bulb



5-11. Sound pressure level data

Outdoor unit

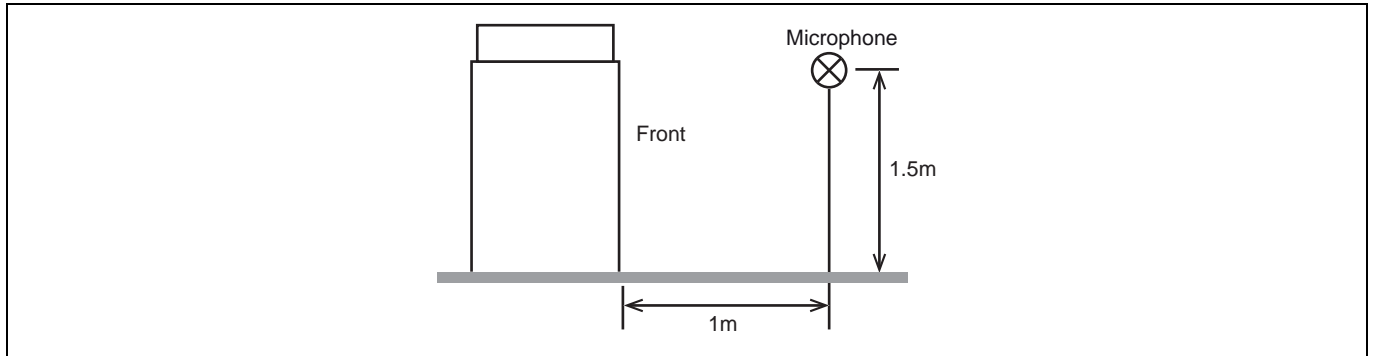

Single unit

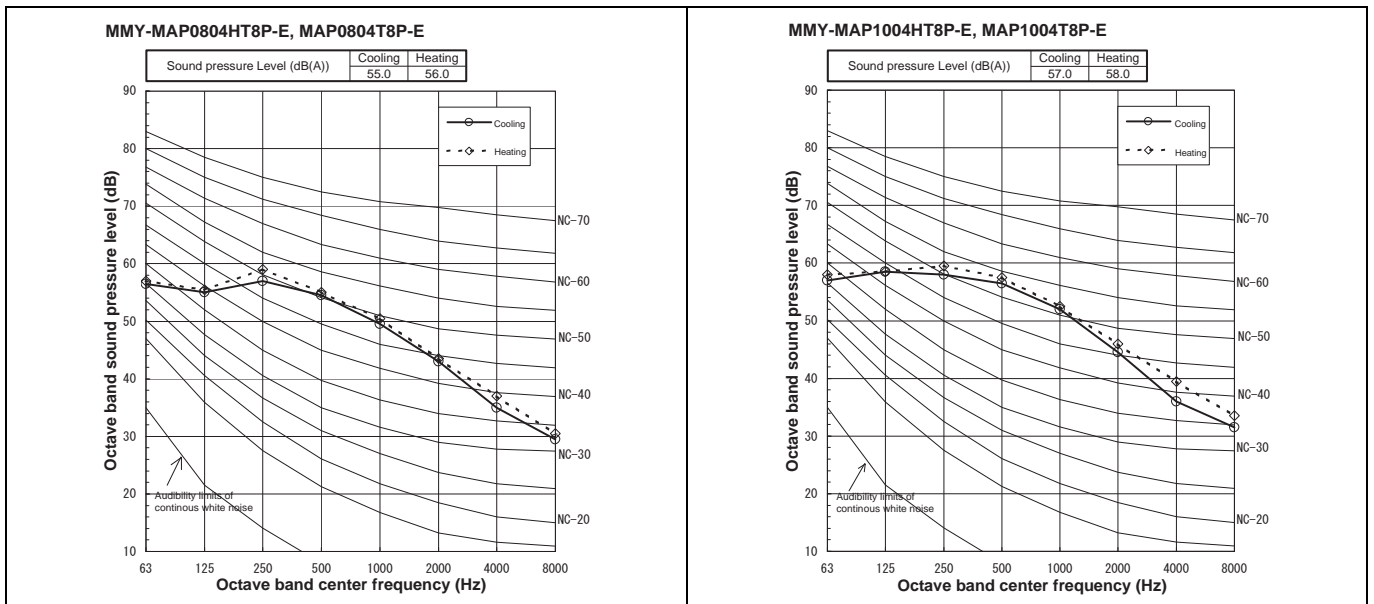



MMY-MAP1204HT8P-E, MAP1204T8P-E

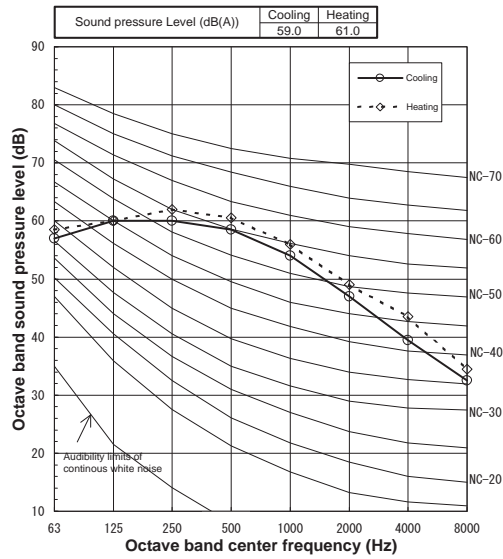

MMY-MAP1404HT8P-E, MAP1404T8P-E

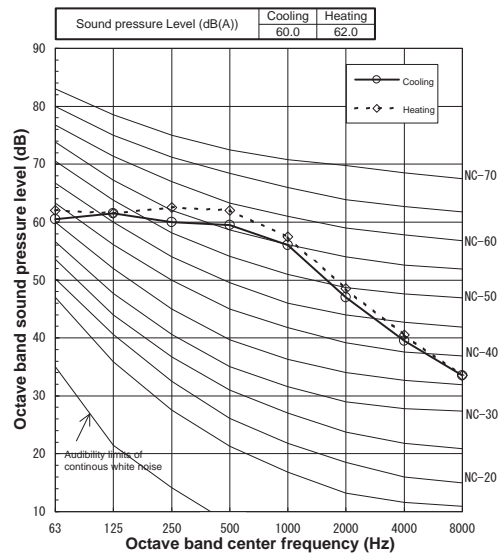

MMY-MAP1604HT8P-E, MAP1604T8P-E

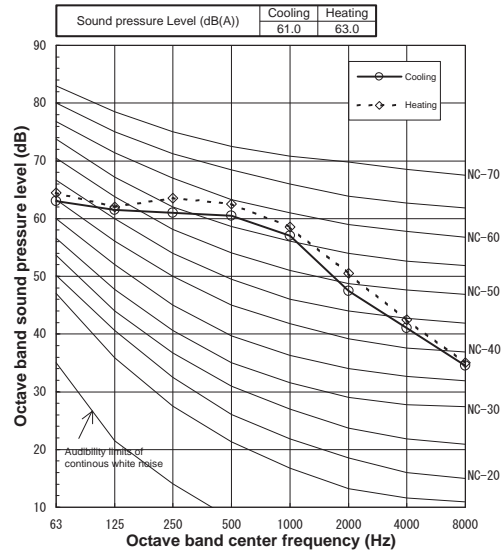



Combination
• Standard model

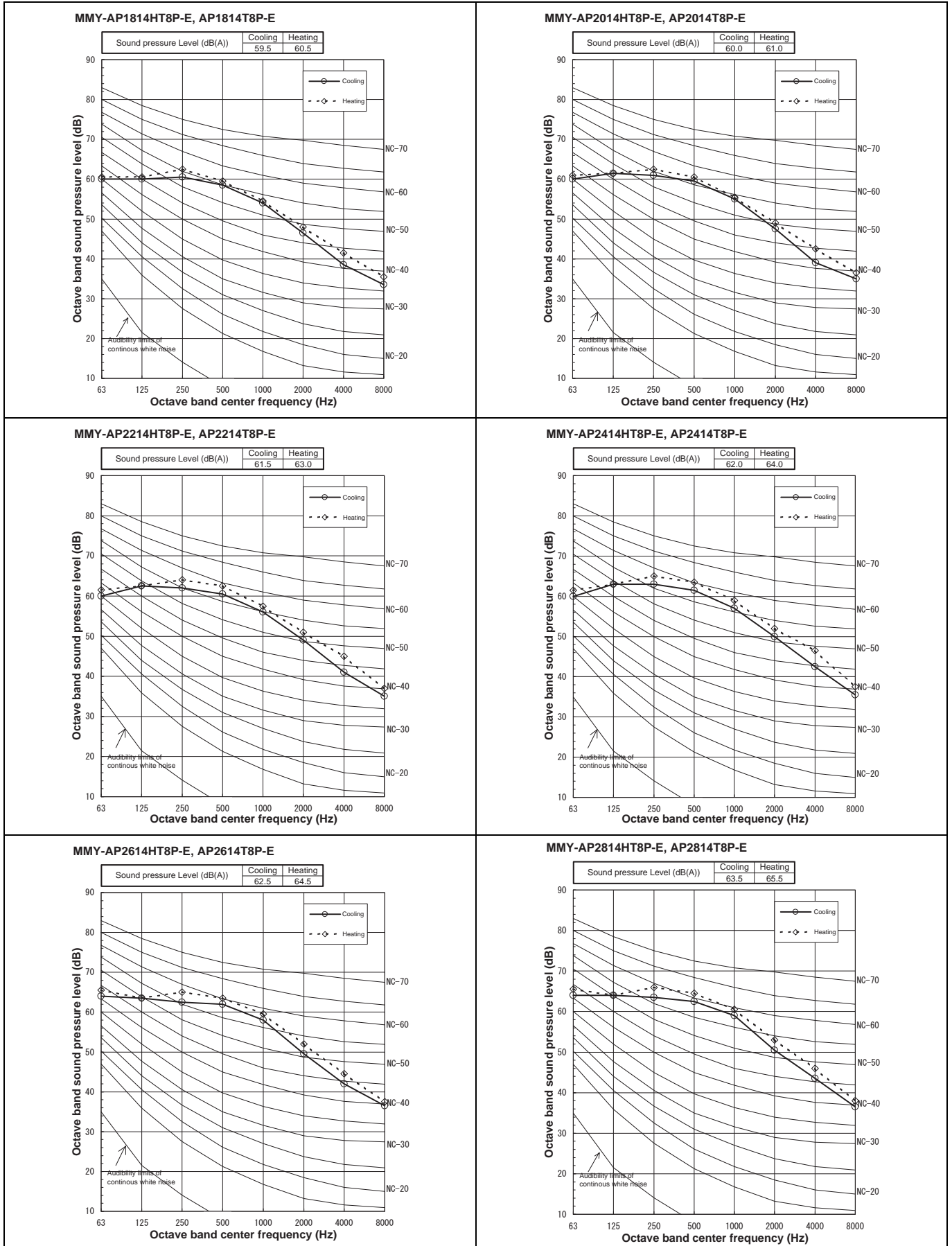



MMY-AP3014HT8P-E, AP3014T8P-E

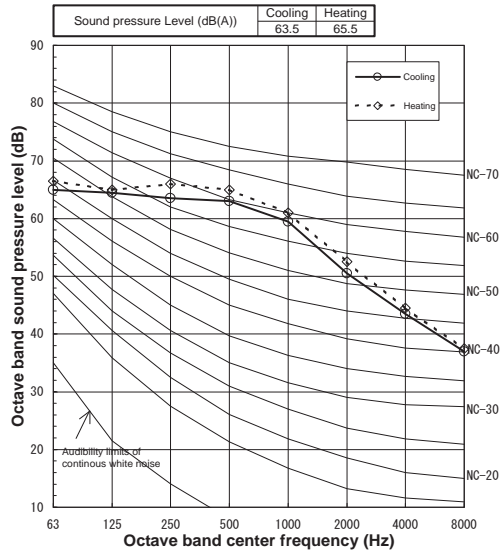

MMY-AP3214HT8P-E, AP3214T8P-E

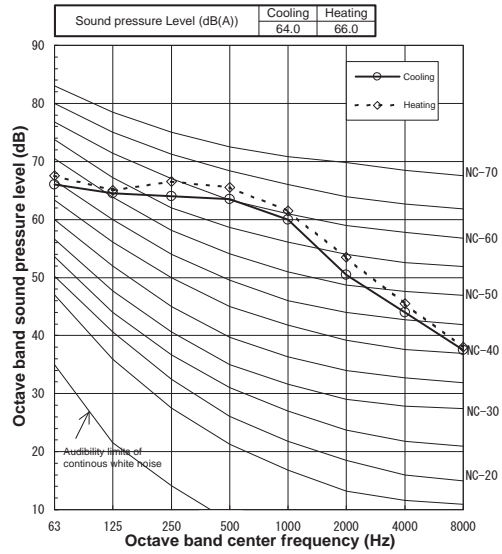

MMY-AP3414HT8P-E, AP3414T8P-E

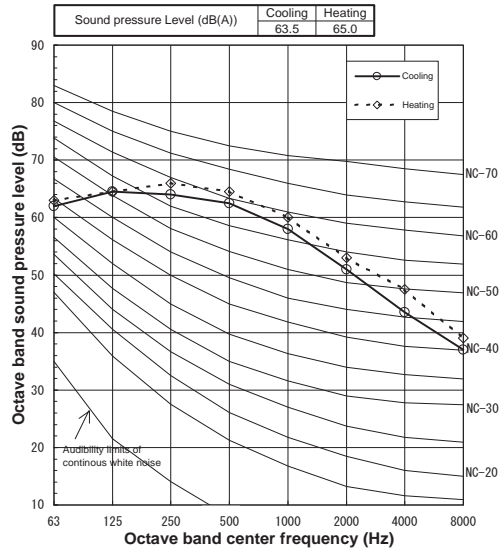

MMY-AP3614HT8P-E, AP3614T8P-E

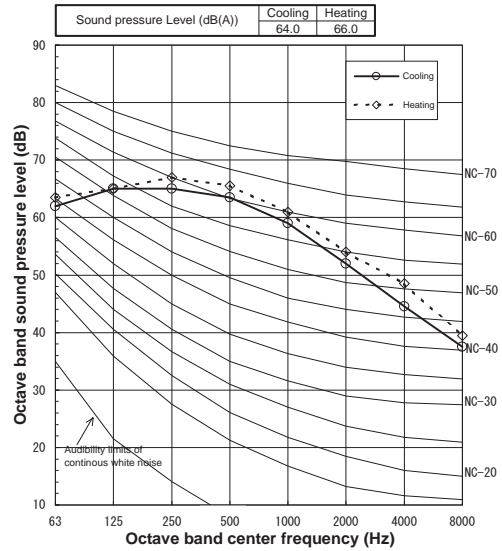

MMY-AP3814HT8P-E, AP3814T8P-E

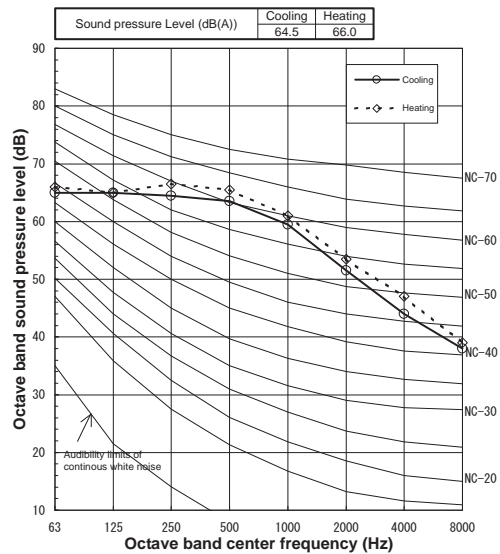

MMY-AP4014HT8P-E, AP4014T8P-E

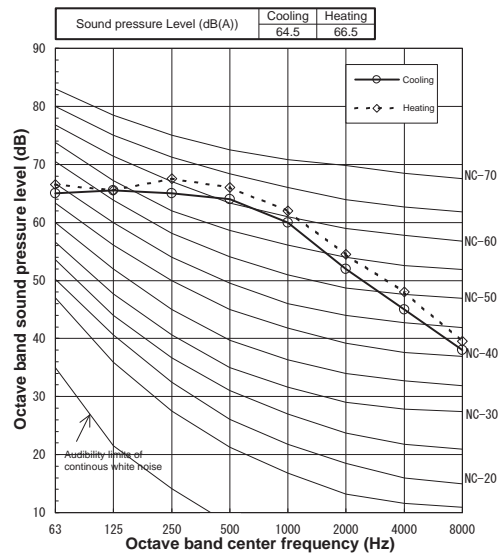

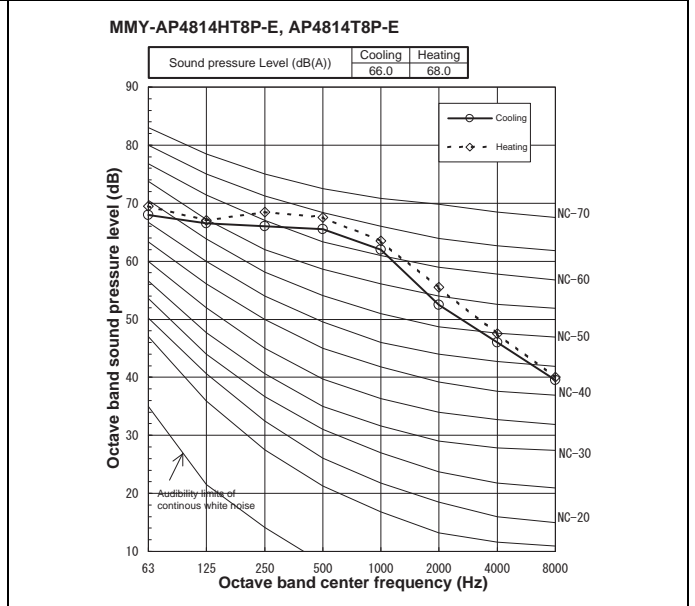
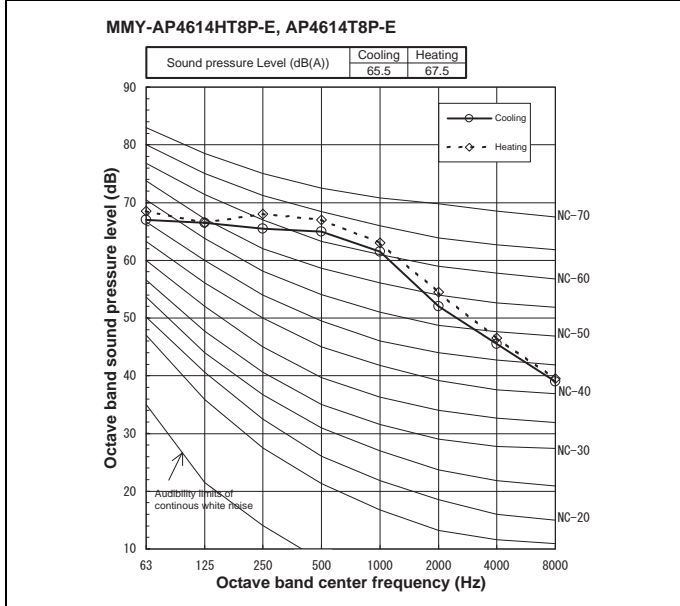
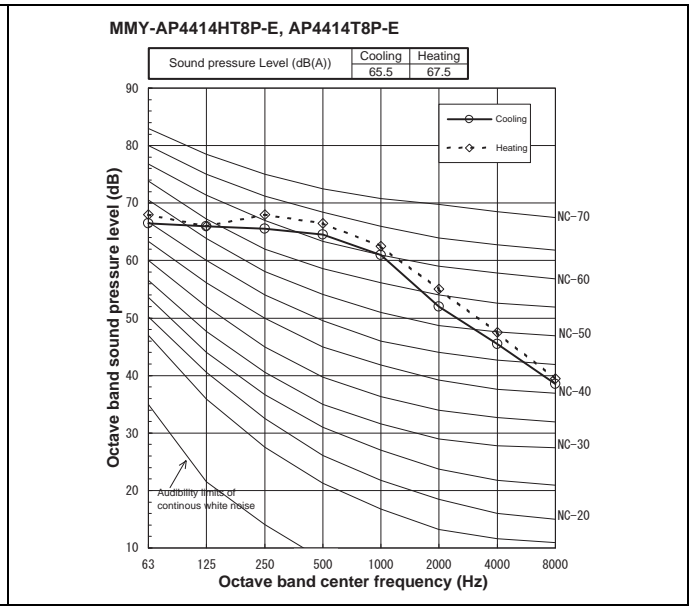
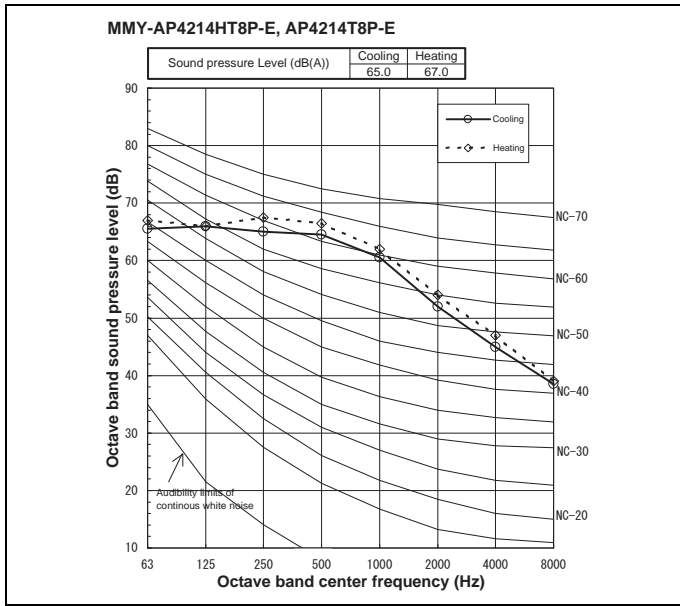

• High efficiency model

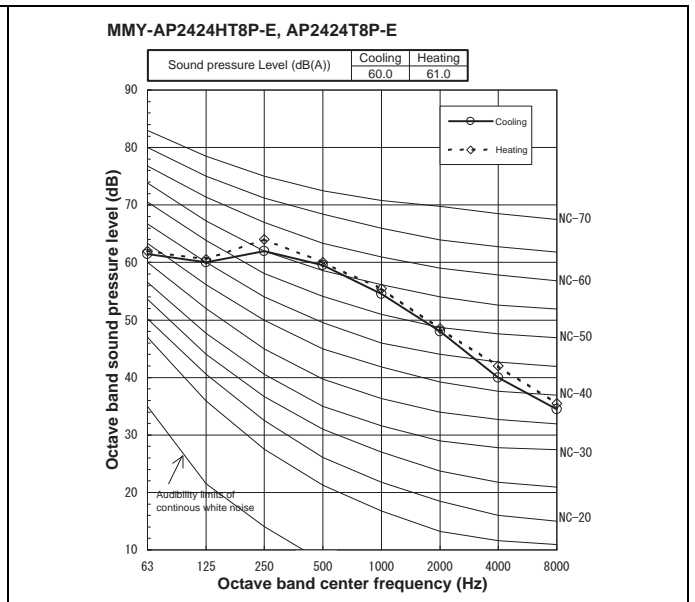
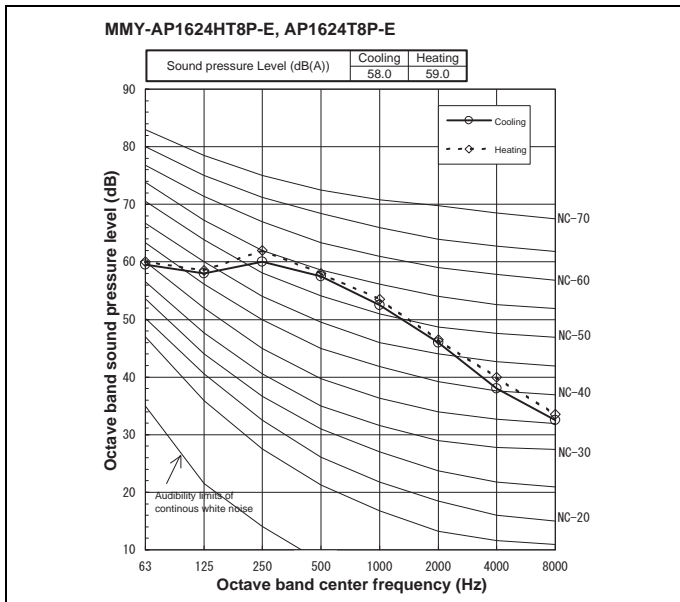



MMY-AP2624HT8P-E, AP2624T8P-E

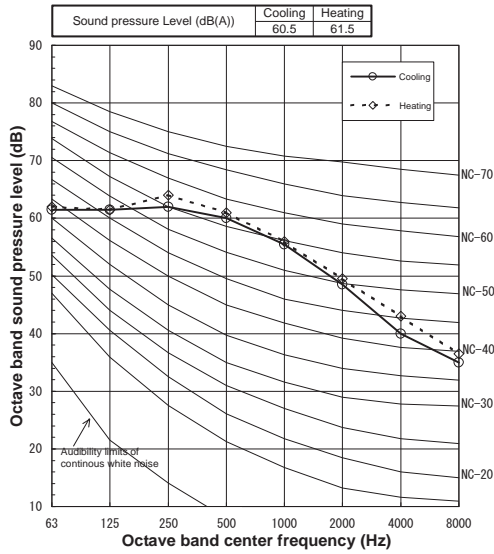

MMY-AP2824HT8P-E, AP2824T8P-E

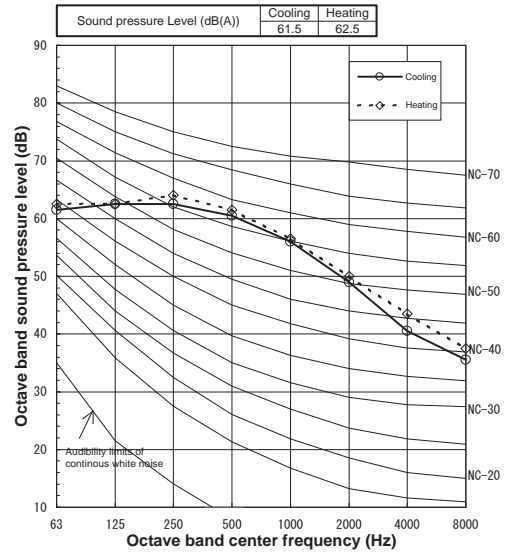

MMY-AP3024HT8P-E, AP3024T8P-E

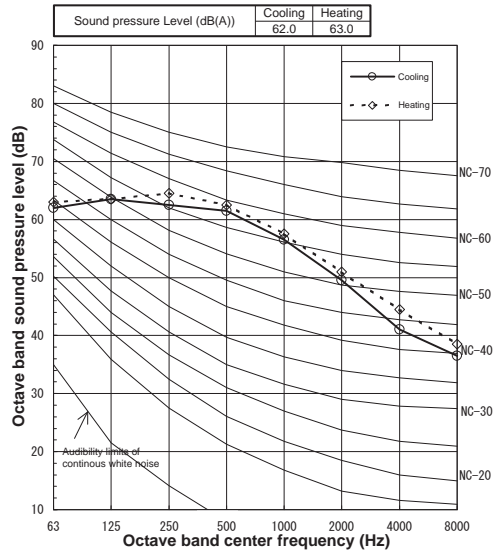

MMY-AP3224HT8P-E, AP3224T8P-E

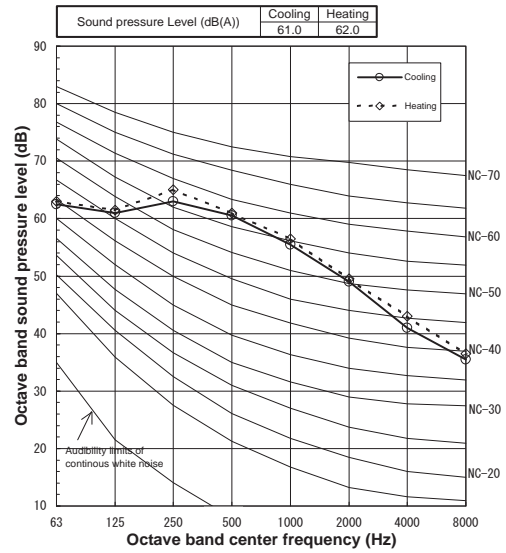

MMY-AP3424HT8P-E, AP3424T8P-E

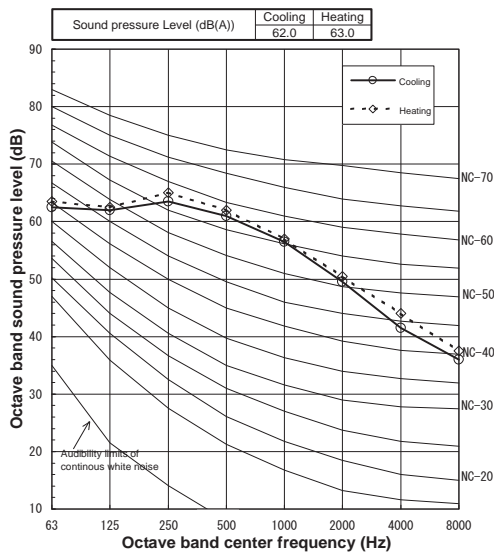

MMY-AP3624HT8P-E, AP3624T8P-E

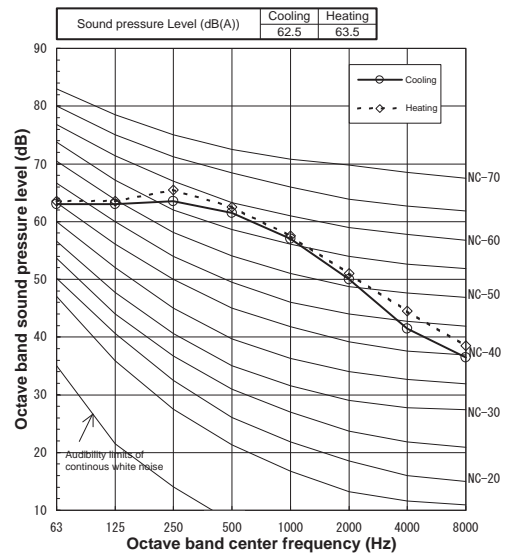



MMY-AP3824HT8P-E, AP3824T8P-E

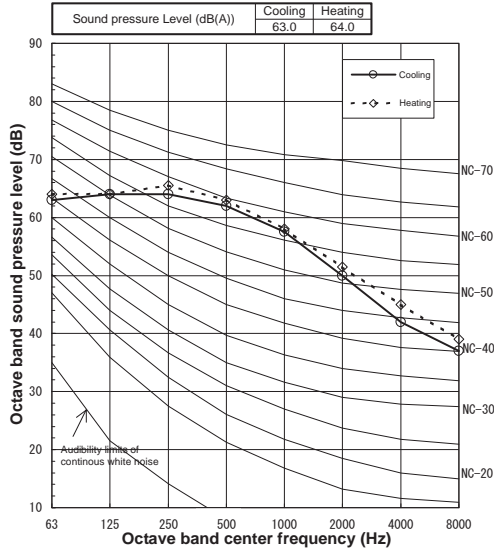

MMY-AP4024HT8P-E, AP4024T8P-E

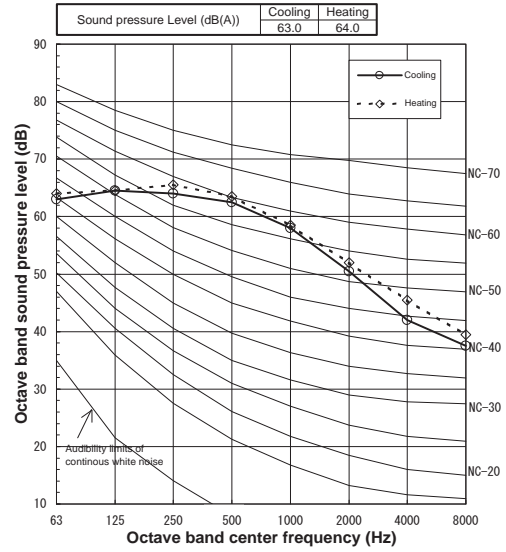

MMY-AP4224HT8P-E, AP4224T8P-E

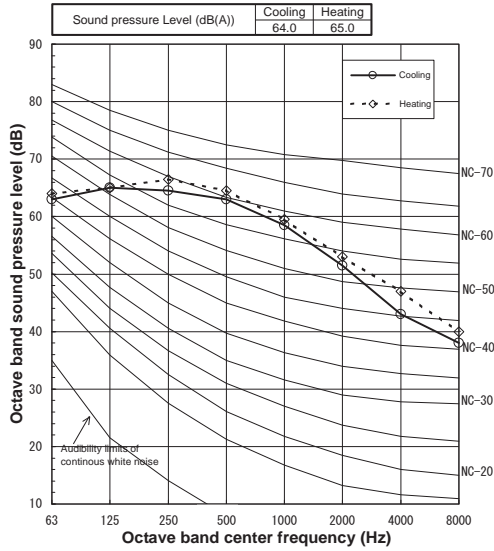

MMY-AP4424HT8P-E, AP4424T8P-E

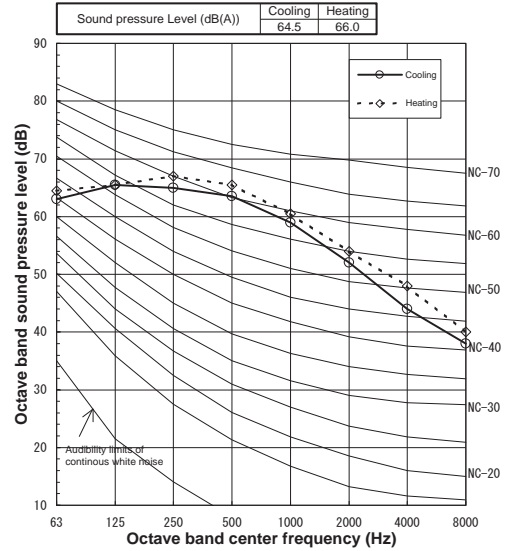

MMY-AP4624HT8P-E, AP4624T8P-E

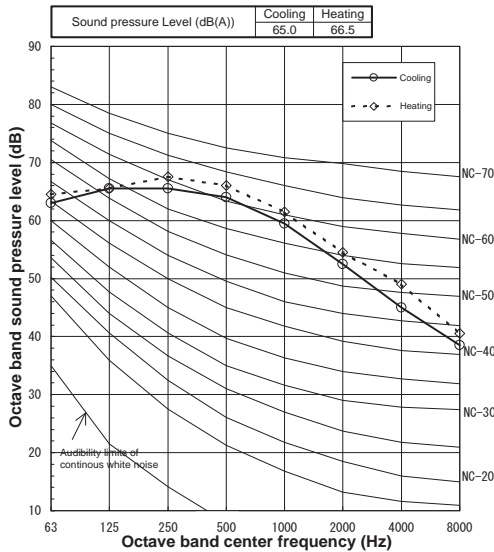

MMY-AP4824HT8P-E, AP4824T8P-E

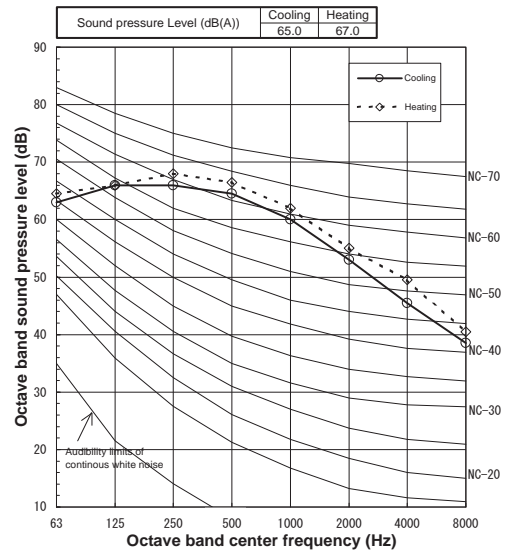

SMMS-i Engineering Data Book

Model name:

MMY-MAP_4HT8P-E

MMY-MAP_4T8P-E

August, 2013 First Edition

TOSHIBA CARRIER CORPORATION