

TOSHIBA

E16-006-1

Leading Innovation >>>

Model name:

MMY-MAP_6FT8P-E

SHRM
SUPER HEAT RECOVERY MULTI



**Engineering
Data Book**

Full Version



Notice: Toshiba is committed to continuously improving its products to ensure the highest quality and reliability standards, and to meet local regulations and market requirements. All features and specifications are subject to change without prior notice.









	Safety caution	2
1	System overview	5
	1-1. Allocation standard of model name	5
	1-2. Summary of system equipments	6
2	Equipment selection procedure	11
	2-1. Selection flow chart	11
	2-2. Combination conditions for indoor unit and outdoor unit	12
	2-3. Cooling/heating capacity characteristics	13
	2-4. Operational temperature range	20
	2-5. Selection procedure for Air to Air Heat exchanger with DX-coil Type	21
3	Refrigerant piping design	22
	3-1. Free branching system	22
	3-2. Allowable length/height difference of refrigerant piping	23
	3-3. Selection of refrigerant piping	26
	3-4. Charging requirement with additional refrigerant	28
4	Wiring design	29
	4-1. General	29
	4-2. Summary of wiring design	29
	4-3. Electrical wiring design	29
	4-4. Outdoor unit power supply	30
	4-5. Indoor unit power supply	31
	4-6. Design of control wiring	33
5	Outdoor unit	35
	5-1. Specifications	35
	5-2. Dimensional drawing	42
	5-3. Center of gravity	54
	5-4. Branch header / Branch joint	55
	5-5. Refrigerant cycle diagram	59
	5-6. Wiring diagram	62
	5-7. Connecting diagram	65
	5-8. Applied control for Outdoor Unit	69
	5-9. Optional printed circuit board (PCB) of outdoor unit	70
	5-10. Part load performance	79
	5-11. Sound pressure level	103
	5-12. FS unit (Flow Selection unit)	109



- Before use, read carefully through the “Safety caution” section to ensure correct operation.
- The important contents concerned to the safety are described in the “Safety cautions”. Be sure to keep them. For Indications and their meanings, see the following description.

■ Warning Indications on the Air Conditioner Unit

Warning indication		Description	
 <table border="1"> <tr> <td>WARNING</td> </tr> <tr> <td>ELECTRICAL SHOCK HAZARD Disconnect all remote electric power supplies</td> </tr> </table>	WARNING	ELECTRICAL SHOCK HAZARD Disconnect all remote electric power supplies	WARNING ELECTRICAL SHOCK HAZARD Disconnect all remote electric power supplies before servicing.
WARNING			
ELECTRICAL SHOCK HAZARD Disconnect all remote electric power supplies			
 <table border="1"> <tr> <td>WARNING</td> </tr> <tr> <td>Moving parts. Do not operate unit with grille removed.</td> </tr> </table>	WARNING	Moving parts. Do not operate unit with grille removed.	WARNING Moving parts. Do not operate unit with grille removed. Stop the unit before the servicing.
WARNING			
Moving parts. Do not operate unit with grille removed.			
 <table border="1"> <tr> <td>CAUTION</td> </tr> <tr> <td>High temperature parts. You might get burned when removing this panel.</td> </tr> </table>	CAUTION	High temperature parts. You might get burned when removing this panel.	CAUTION High temperature parts. You might get burned when removing this panel.
CAUTION			
High temperature parts. You might get burned when removing this panel.			
 <table border="1"> <tr> <td>CAUTION</td> </tr> <tr> <td>Do not touch the aluminum fins of the unit. Doing so may result in injury.</td> </tr> </table>	CAUTION	Do not touch the aluminum fins of the unit. Doing so may result in injury.	CAUTION Do not touch the aluminium fins of the unit. Doing so may result in injury.
CAUTION			
Do not touch the aluminum fins of the unit. Doing so may result in injury.			
 <table border="1"> <tr> <td>CAUTION</td> </tr> <tr> <td>BURST HAZARD Open the service valves before the operation,</td> </tr> </table>	CAUTION	BURST HAZARD Open the service valves before the operation,	CAUTION BURST HAZARD Open the service valves before the operation, otherwise there might be the burst.
CAUTION			
BURST HAZARD Open the service valves before the operation,			
 <table border="1"> <tr> <td>CAUTION</td> </tr> <tr> <td>Do not climb onto the fan guard. Doing so may result in</td> </tr> </table>	CAUTION	Do not climb onto the fan guard. Doing so may result in	CAUTION Do not climb onto the fan guard. Doing so may result in injury.
CAUTION			
Do not climb onto the fan guard. Doing so may result in			

■ **Explanation of indications**

 **WARNING**

Indicates possibilities that a death or serious injury of personnel is caused by an incorrect handling.

 **CAUTION**

Indicates contents that an injury (*1) or property damage (*2) only may be caused when an incorrect work has been executed.

*1: "Injury" means a hurt, a burn, or an electric shock which does not require hospitalization or a long-term going to the hospital.

*2: "Property damage means an enlarged damage concerned to property, or breakage of materials.

- **After installation work has finished, check there is no trouble by a test operation, and explain using method and maintenance method to the customers based on the Owner's Manual.**

Please ask the customers to keep this Installation Manual together with the Owner's Manual.

 **WARNING**

Ask a shop or a professional dealer to install the air conditioner.

If you will install by yourself, a fire, an electric shock, or water leak is caused.

Take measures so that the refrigerant does not exceed the limit concentration even if it leaks when installing the air conditioner in a small room.

For the measures not to exceed the limit of concentration, contact the dealer. If the refrigerant leaks and it exceeds the limit of concentration, an accident of oxygen shortage is caused.

Install the air conditioner at a place which is satisfactorily bearable to weight.

If strength is insufficient, the unit may fall down resulting in human injury.

Perform a specified installation work against a strong wind such as typhoon or earthquake.

If the air conditioner is imperfectly installed, an accident by falling or dropping may be caused.

If refrigerant gas leaks during installation work, ventilate the room.

If the leaked refrigerant gas approaches to fire, noxious gas may generate.

After installation work, confirm that refrigerant gas does not leak.

If refrigerant gas leaks in the room, and approaches to fire such as fan heater, stove or kitchen range, generation of noxious gas may be caused.

Never recover refrigerant in the outdoor unit.

Be sure to use a refrigerant recovery device to recover refrigerant in reinstallation or repair work.

Recovery of refrigerant in the outdoor unit is unavailable; otherwise a serious accident such as crack or human injury is caused.

A person qualified for the electric work should deal with the electric construction conforming to the regulations of the local electric company and the Installation Manual. Be sure to use the exclusive circuit.

If there is capacity shortage of the power supply circuit or incomplete installation, a fire or an electric shock is caused.

For cabling, use the specified cables and connect them securely so that external force of cable does not transmit to the terminal connecting section.

If connection or fixing is incomplete, a fire, etc. may be caused.

Be sure to connect earth wire.

Do not connect earth wire to gas pipe, water pipe, lightning rod, nor earth wire of telephone.

If grounding is incomplete, an electric shock is caused.

 **CAUTION**

Do not install the air conditioner at a place where combustible gas may leak.

If gas leaks and is collected at surrounding the unit, the production of fire may be caused.

Be sure to attach an earth leakage breaker; otherwise an electric shock may be caused.

Using a torque wrench, tighten the flare nut in the specified method.

If the flare nut is exceedingly tightened, the flare nut is broken and a refrigerant leakage may be caused after a long time has passed.

WARNINGS ON REFRIGERANT LEAKAGE

Check of Concentration Limit

The room in which the air conditioner is to be installed requires a design that in the event of refrigerant gas leaking out, its concentration will not exceed a set limit.

The refrigerant R410A which is used in the air conditioner is safe, without the toxicity or combustibility of ammonia, and is not restricted by laws to be imposed which protect the ozone layer. However, since it contains more than air, it poses the risk of suffocation if its concentration should rise excessively.

Suffocation from leakage of R410A is almost nonexistent. With the recent increase in the number of high concentration buildings, however, the installation of multi air conditioner systems is on the increase because of the need for effective use of floor space, individual control, energy conservation by curtailing heat and carrying power etc.

Most importantly, the multi air conditioner system is able to replenish a large amount of refrigerant compared with conventional individual air conditioners. If a single unit of the multi conditioner system is to be installed in a small room, select a suitable model and installation procedure so that if the refrigerant accidentally leaks out, its concentration does not reach the limit (and in the event of an emergency, measures can be made before injury can occur).

In a room where the concentration may exceed the limit, create an opening with adjacent rooms, or install mechanical ventilation combined with a gas leak detection device.

The concentration is as given below.

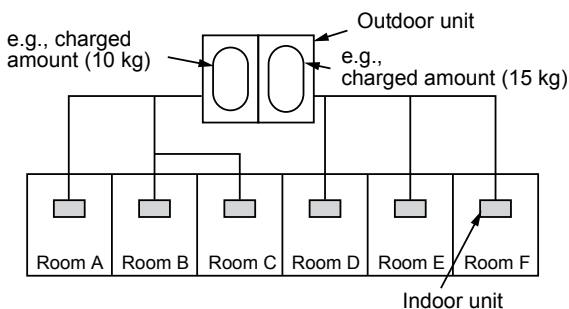
$$\frac{\text{Total amount of refrigerant (kg)}}{\text{Min. volume of the indoor unit installed room (m}^3\text{)}} \leq \text{Concentration limit (kg/m}^3\text{)}$$

Concentration limit

Compliance to the local applicable regulations and standards for the concentration limit is required.

NOTE 1:

If there are 2 or more refrigerating systems in a single refrigerating device, the amounts of refrigerant should be as charged in each independent device.



For the amount of charge in this example:

The possible amount of leaked refrigerant gas in rooms A, B and C is 10 kg.

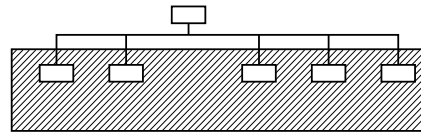
The possible amount of leaked refrigerant gas in rooms D, E and F is 15 kg.

Important

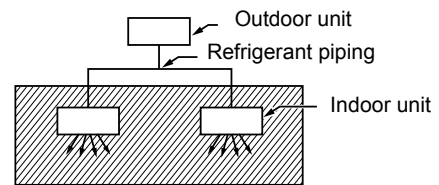
NOTE 2:

The standards for minimum room volume are as follows.

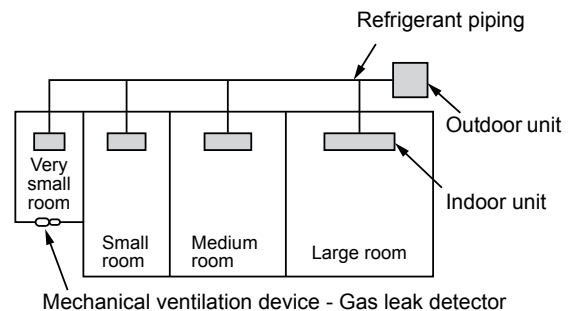
- (1) No partition (shaded portion)



- (2) When there is an effective opening with the adjacent room for ventilation of leaking refrigerant gas (opening without a door, or an opening 0.15 % or larger than the respective floor spaces at the top or bottom of the door).

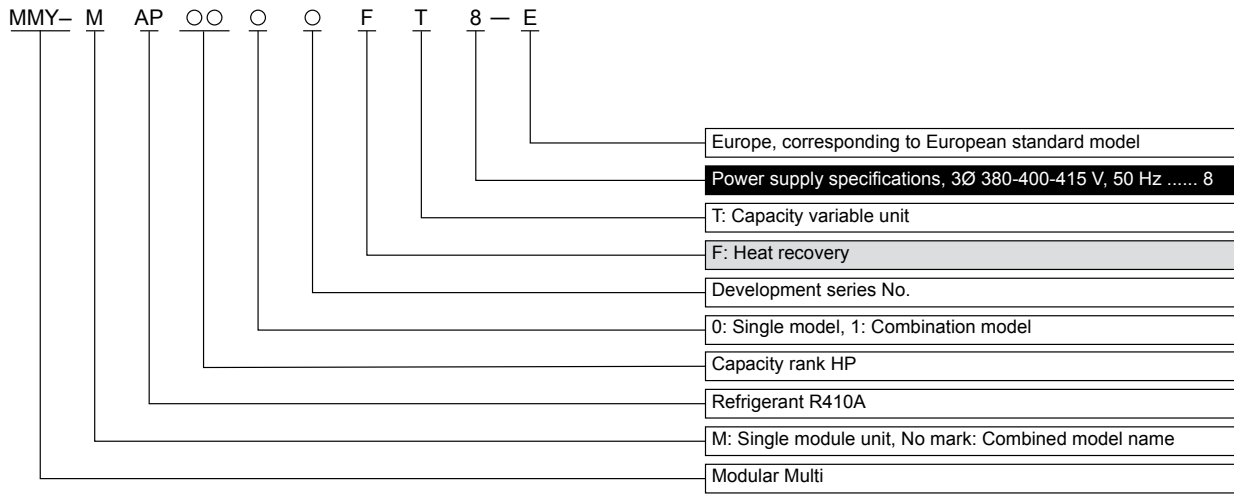


- (3) If an indoor unit is installed in each partitioned room and the refrigerant tubing is interconnected, the smallest room of course becomes the object. But when a mechanical ventilation is installed interlocked with a gas leakage detector in the smallest room where the density limit is exceeded, the volume of the next smallest room becomes the object.





1-1. Allocation standard of model name SHRM-e





1-2. Summary of system equipments

1-2-1. Outdoor units

Corresponding HP			8HP	10HP	12HP	14HP	16HP	18HP	20HP
Model name	MMY-		MAP0806FT8P-E	MAP1006FT8P-E	MAP1206FT8P-E	MAP1406FT8P-E	MAP1606FT8P-E	MAP1806FT8P-E	MAP2006FT8P-E
Cooling capacity	nominal	(kW)	22.4	28.0	33.5	40.0	45.0	50.4	56.0
	maximum	(kW)	25.0	31.5	37.5	45.0	50.0	56.5	58.0
Heating capacity			22.4	28.0	33.5	40.0	45.0	50.4	56.0
Power supply			3 phase 50Hz 400V(380-415V)						
No. of connectable indoor units (*)			18	22	27	31	36	40	41

■ Combination of outdoor units

Corresponding HP			22HP	24HP	26HP	28HP	30HP	32HP	34HP
Model name	MMY-		AP2216FT8P-E	AP2416FT8P-E	AP2616FT8P-E	AP2816FT8P-E	AP3016FT8P-E	AP3216FT8P-E	AP3416FT8P-E
Cooling capacity	nominal	(kW)	61.5	68.0	73.5	80.0	85.0	90.4	95.4
	maximum	(kW)	69.0	76.5	82.5	90.0	95.0	101.5	106.5
Heating capacity			61.5	68.0	73.5	80.0	85.0	90.4	95.4
Power supply			3 phase 50Hz 400V(380-415V)						
Combined outdoor units			12HP	14HP	14HP	14HP	16HP	18HP	18HP
			10HP	10HP	12HP	14HP	14HP	14HP	16HP
			-	-	-	-	-	-	-
No. of connectable indoor units (*)			49	54	58	63	64	64	64

Corresponding HP			36HP	38HP	40HP	42HP	44HP	46HP	48HP
Model name	MMY-		AP3616FT8P-E	AP3816FT8P-E	AP4016FT8P-E	AP4216FT8P-E	AP4416FT8P-E	AP4616FT8P-E	AP4816FT8P-E
Cooling capacity	nominal	(kW)	100.8	106.4	112.0	120.0	125.0	130.4	135.4
	maximum	(kW)	113.0	114.5	116.0	135.0	140.0	146.0	151.5
Heating capacity			100.8	106.4	112.0	120.0	125.0	130.4	135.4
Power supply			3 phase 50Hz 400V(380-415V)						
Combined outdoor units			18HP	20HP	20HP	14HP	16HP	18HP	18HP
			18HP	18HP	20HP	14HP	14HP	14HP	16HP
			-	-	-	14HP	14HP	14HP	14HP
No. of connectable indoor units (*)			64	64	64	64	64	64	64

Corresponding HP			50HP	52HP	54HP
Model name	MMY-		AP5016FT8P-E	AP5216FT8P-E	AP5416FT8P-E
Cooling capacity	nominal	(kW)	140.8	145.8	151.2
	maximum	(kW)	158.0	163.0	169.5
Heating capacity			140.8	145.8	151.2
Power supply			3 phase 50Hz 400V(380-415V)		
Combined outdoor units			18HP	18HP	18HP
			18HP	18HP	18HP
			14HP	16HP	18HP
No. of connectable indoor units (*)			64	64	64

(*) Under centralized control maximum 54 unit.

1-2-2. Indoor Unit



Type	Appearance	Model name	Capacity rank	Capacity Code	Cooling capacity(kW)	Heating capacity(kW)
4-way Air Discharge Cassette Type		MMU-AP0094HP1-E	009	1	2.8	3.2
		MMU-AP0124HP1-E	012	1.25	3.6	4.0
		MMU-AP0154HP1-E	015	1.7	4.5	5.0
		MMU-AP0184HP1-E	018	2	5.6	6.3
		MMU-AP0244HP1-E	024	2.5	7.1	8.0
		MMU-AP0274HP1-E	027	3	8.0	9.0
		MMU-AP0304HP1-E	030	3.2	9.0	10.0
		MMU-AP0364HP1-E	036	4	11.2	12.5
		MMU-AP0484HP1-E	048	5	14.0	16.0
Compact 4-way Cassette (600 x 600) Type		MMU-AP0056MH1-E	005	0.6	1.7	1.9
		MMU-AP0074MH1-E	007	0.8	2.2	2.5
		MMU-AP0094MH1-E	009	1	2.8	3.2
		MMU-AP0124MH1-E	012	1.25	3.6	4.0
		MMU-AP0154MH1-E	015	1.7	4.5	5.0
		MMU-AP0184MH1-E	018	2	5.6	6.3
		MMU-AP0057MH-E	005	0.6	1.7	1.9
		MMU-AP0077MH-E	007	0.8	2.2	2.5
		MMU-AP0097MH-E	009	1	2.8	3.2
Compact 4-way Cassette		MMU-AP0127MH-E	012	1.25	3.6	4.0
		MMU-AP0157MH-E	015	1.7	4.5	5.0
		MMU-AP0187MH-E	018	2	5.6	6.3
		MMU-AP0072WH1	007	0.8	2.2	2.5
		MMU-AP0092WH1	009	1	2.8	3.2
		MMU-AP0122WH1	012	1.25	3.6	4.0
		MMU-AP0152WH1	015	1.7	4.5	5.0
		MMU-AP0182WH1	018	2	5.6	6.3
		MMU-AP0242WH1	024	2.5	7.1	8.0
2-way Air Discharge Cassette Type		MMU-AP0272WH1	027	3	8.0	9.0
		MMU-AP0302WH1	030	3.2	9.0	10.0
		MMU-AP0362WH1	036	4.0	11.2	12.5
		MMU-AP0482WH1	048	5.0	14.0	16.0
		MMU-AP0562WH1	056	6	16.0	18.0
		MMU-AP0074YH1-E	007	0.8	2.2	2.5
		MMU-AP0094YH1-E	009	1.0	2.8	3.2
		MMU-AP0124YH1-E	012	1.3	3.6	4.0
		MMU-AP0154SH1-E	015	1.7	4.5	5.0
1-way Air Discharge Cassette Type		MMU-AP0184SH1-E	018	2.0	5.6	6.3
		MMU-AP0244SH1-E	024	2.5	7.1	8.0
		MMD-AP0076BHP1-E	007	0.80	2.2	2.5
		MMD-AP0096BHP1-E	009	1.00	2.8	3.2
		MMD-AP0126BHP1-E	012	1.25	3.6	4.0
		MMD-AP0156BHP1-E	015	1.70	4.5	5.0
		MMD-AP0186BHP1-E	018	2.00	5.6	6.3
		MMD-AP0246BHP1-E	024	2.50	7.1	8.0
		MMD-AP0276BHP1-E	027	3.00	8.0	9.0
Concealed Duct Type		MMD-AP0306BHP1-E	030	3.20	9.0	10.0
		MMD-AP0366BHP1-E	036	4.00	11.2	12.5
		MMD-AP0486BHP1-E	048	5.00	14.0	16.0
		MMD-AP0566BHP1-E	056	6.00	16.0	18.0
		MMD-AP0056SPH1-E	005	0.6	1.7	1.9
		MMD-AP0074SPH1-E	007	0.80	2.2	2.5
		MMD-AP0094SPH1-E	009	1.00	2.8	3.2
		MMD-AP0124SPH1-E	012	1.25	3.6	4.0
		MMD-AP0154SPH1-E	015	1.70	4.5	5.0
Slim Duct Type		MMD-AP0184SPH1-E	018	2.00	5.6	6.3
		MMD-AP0244SPH1-E	024	2.25	7.1	8.0
		MMD-AP0274SPH1-E	027	3.0	8.0	9.0
		MMD-AP0186HP1-E	018	2.0	5.6	6.3
		MMD-AP0246HP1-E	024	2.5	7.1	8.0
		MMD-AP0276HP1-E	027	3.0	8.0	9.0
		MMD-AP0366HP1-E	036	4.0	11.2	12.5
		MMD-AP0486HP1-E	048	5.0	14.0	16.0
		MMD-AP0566HP1-E	056	6.0	16.0	18.0
Concealed Duct High Static Pressure Type		MMD-AP0726HP-E	072	8.0	22.4	25.0
		MMD-AP0966HP-E	096	10.0	28.0	31.5
		MMC-AP0158HP-E	015	1.7	4.5	5.0
		MMC-AP0188HP-E	018	2.0	5.6	6.3
		MMC-AP0248HP-E	024	2.5	7.1	8.0
		MMC-AP0278HP-E	027	3.0	8.0	9.0
		MMC-AP0368HP-E	036	4.0	11.2	12.5
		MMC-AP0488HP-E	048	5.0	14.0	16.0
		MMC-AP0568HP-E	056	6.0	16.0	18.0
Under Ceiling Type						

Indoor Unit






Type	Appearance	Model name	Capacity rank	Capacity Code	Cooling capacity(kW)	Heating capacity(kW)
High Wall Type 3 series		MMK-AP0073H1	007	0.8	2.2	2.5
		MMK-AP0093H1	009	1.0	2.8	3.2
		MMK-AP0123H1	012	1.25	3.6	4.0
		MMK-AP0153H1	015	1.70	4.5	5.0
		MMK-AP0183H1	018	2.00	5.6	6.3
		MMK-AP0243H1	024	2.50	7.1	8.0
High Wall Type 3 series (Without PMV)		MMK-AP0073HP1-E1	007	0.8	2.2	2.5
		MMK-AP0093HP1-E1	009	1.0	2.8	3.2
		MMK-AP0123HP1-E1	012	1.25	3.6	4.0
		MMK-AP0153HP1-E1	015	1.70	4.5	5.0
		MMK-AP0183HP1-E1	018	2.00	5.6	6.3
		MMK-AP0243HP1-E1	024	2.50	7.1	8.0
High Wall Type 4 series		MMK-AP0054MHP1-E	005	0.6	1.7	1.9
		MMK-AP0074MH1-E	007	0.8	2.2	2.5
		MMK-AP0094MH1-E	009	1	2.8	3.2
		MMK-AP0124MH1-E	012	1.25	3.6	4.0
High Wall Type 4 series (Without PMV)		MMK-AP0054MHP1-E1	005	0.6	1.7	1.9
		MMK-AP0074MHP1-E1	007	0.8	2.2	2.5
		MMK-AP0094MHP1-E1	009	1	2.8	3.2
		MMK-AP0124MHP1-E1	012	1.25	3.6	4.0
Floor Standing Concealed Type		MML-AP0074BH1-E	007	0.8	2.2	2.5
		MML-AP0094BH1-E	009	1	2.8	3.2
		MML-AP0124BH1-E	012	1.25	3.6	4.0
		MML-AP0154BH1-E	015	1.7	4.5	5.0
		MML-AP0184BH1-E	018	2	5.6	6.3
		MML-AP0244BH1-E	024	2.5	7.1	8.0
Floor Standing Cabinet Type		MML-AP0074H1-E	007	0.8	2.2	2.5
		MML-AP0094H1-E	009	1	2.8	3.2
		MML-AP0124H1-E	012	1.25	3.6	4.0
		MML-AP0154H1-E	015	1.7	4.5	5.0
		MML-AP0184H1-E	018	2	5.6	6.3
		MML-AP0244H1-E	024	2.5	7.1	8.0
Floor Standing Type		MMF-AP0156H1-E	015	1.7	4.5	5.0
		MMF-AP0186H1-E	018	2	5.6	6.3
		MMF-AP0246H1-E	024	2.5	7.1	8.0
		MMF-AP0276H1-E	027	3	8.0	9.0
		MMF-AP0366H1-E	036	4	11.2	12.5
		MMF-AP0486H1-E	048	5	14.0	16.0
		MMF-AP0566H1-E	056	6.0	16.0	18.0
Console Type		MML-AP0074NH1-E	007	0.8	2.2	2.5
		MML-AP0094NH1-E	009	1	2.8	3.2
		MML-AP0124NH1-E	012	1.3	3.6	4.0
		MML-AP0154NH1-E	015	1.7	4.5	5.0
		MML-AP0184NH1-E	018	2.0	5.6	6.3
Air to Air Heat exchanger with DX-coil Type		MMD-VN502HEX1E	009	1	4.10(1.30)*	5.53(2.33)*
		MMD-VN802HEX1E	015	1.7	6.56(2.06)*	8.61(3.61)*
		MMD-VN1002HEX1E	018	2	8.25(2.32)*	10.92(4.32)*
Air to Air Heat exchanger with DX-coil Humidifier Type		MMD-VNK502HEX1E	009	1	4.10(1.30)*	5.53(2.33)*
		MMD-VNK802HEX1E	015	1.7	6.56(2.06)*	8.61(3.61)*
		MMD-VNK1002HEX1E	018	2	8.25(2.32)*	10.92(4.32)*

* : The figures in () indicate the heat reclaimed from the heat recovery ventilator.

1-2-3. FS units (Flow selector units)

Model name	Appearance	Remarks
RBM-Y1123FE		
RBM-Y1803FE		
RBM-Y2803FE		
RBM-Y1801F4PE		
RBM-Y1801F6PE		

1-2-4. Branching joints and headers

Name	Model name	Appearance	Remarks
Y-shape branching joint	RBM-BY55FE		For 3 piping
	RBM-BY105FE		
	RBM-BY205FE		
	RBM-BY305FE		
Y-shape branching joint	RBM-BY55E		For 2 piping
	RBM-BY105E		
	RBM-BY205E		
	RBM-BY305E		
4-branching header	RBM-HY1043FE		For 3 piping
	RBM-HY2043FE		For 2 piping
	RBM-HY1043E		
	RBM-HY2043E		
8-branching header	RBM-HY1083FE		For 3 piping
	RBM-HY2083FE		For 2 piping
	RBM-HY1083E		
	RBM-HY2083E		
Branching joint for connection of outdoor units	RBM-BT14FE		
	RBM-BT24FE		



1-2-5. Remote controllers

Name	Model name	Remarks
Wired remote controller	RBC-AMT32E	
	RBC-AMS54E-EN/ES	-EN : English, Italian, Polish, Greece, Russian, Turkish -ES : English, Spanish, Portuguese, French, Dutch, German
Simple wired remote controller	RBC-AS41E	
Wireless remote controller kit	RBC-AX32U(W)-E RBC-AX32U(WS)-E	For 4-way Air Discharge Cassette
	RBC-AX33CE	For Under Ceiling, 1-way Air Discharge Cassette SH
	TCB-AX32E	For Compact 4-way Cassette, 1-way Air Discharge Cassette YH, Concealed Duct Standard, Slim Duct, Floor Standing Cabinet, Floor Standing
	RBC-AX23UW(W)-E	For 2-way Air Discharge Cassette
ON-OFF controller	TCB-CC163TLE2	
Central remote controller	BMS-CM1280TLE	
Schedule timer	TCB-EXS21TLE	
Remote controller with schedule timer (7-day timer function)	RBC-AMS41E	
Wired remote controller for Air to Air Heat Exchanger with DX coil unit	NRC-01HE	

1-2-6. Optional PCB of outdoor unit

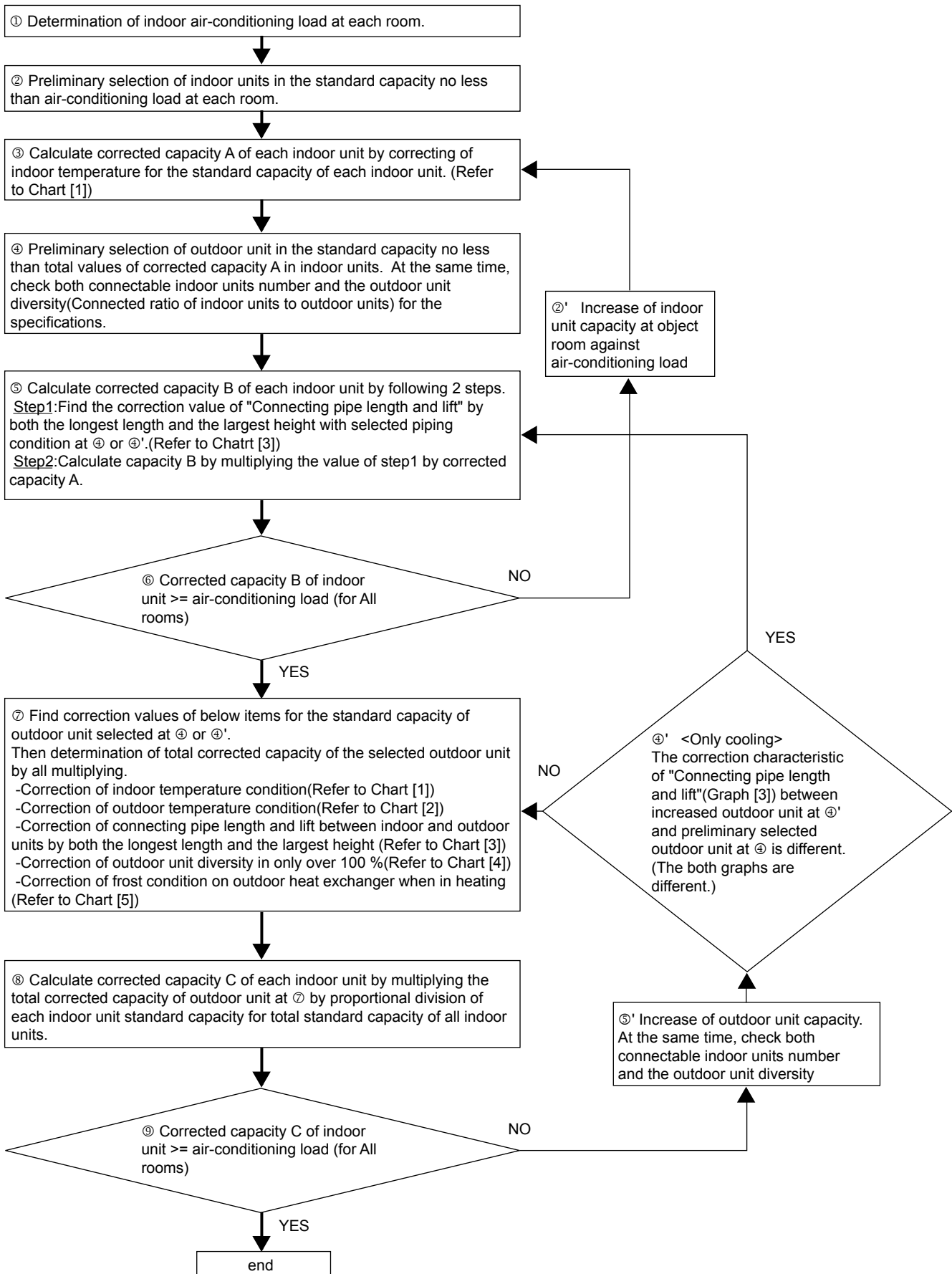
Name	Model name	Remarks
Power peak-cut control board	TCB-PCDM4E	
External master ON/OFF control board	TCB-PCMO4E	
Output control board	TCB-PCIN4E	

1-2-7. Controls

Name	Model name	Remarks
Touch Screen Controller	BMS-CT5121E	
Smart BMS manager	BMS-SM1280HTLE	
Smart BMS manager with data analyze	BMS-SM1280ETLE	
TCS-NET Relay Interface	BMS-IFLSV4E	
Energy Monitoring Relay Interface	BMS-IFWH5E	
Digital I/O Relay Interface	BMS-IFDD03E	
LonWorks LN Interface	TCB-IFLN642TLE	
BACnet Server	BMS-LSV9E	
	BMS-STBN10E	
Modbus Interface	TCB-IFMB641TLE	
Analog Interface	TCB-IFCB640TLE	
BN Interface	BMS-IFBN640TLE	



2-1. Selection flow chart





2-2. Combination conditions for indoor unit and outdoor unit

2-2-1. For indoor unit, the capacity code is decided for each capacity rank.

Capacity rank type	005	007	009	012	015	018	024	027	030	036	048	056	072	096
Capacity code	0.6	0.8	1	1.25	1.7	2	2.5	3	3.2	4	5	6	8	10

NOTE:

Capacity rank: Correspondence to Btu/h.

Capacity code: Correspondence to Horsepower.

2-2-2.outdoor unit connectable indoor units

Outdoor unit(Heat recovery)	Capacity code of outdoor unit	max.number of indoor units	Total capacity code of indoor units
MMY-MAP0806FT8P-E	8	18	5.6 to 10.8
MMY-MAP1006FT8P-E	10	22	7.0 to 13.5
MMY-MAP1206FT8P-E	12	27	8.4 to 16.2
MMY-MAP1406FT8P-E	14	31	9.8 to 18.9
MMY-MAP1606FT8P-E	16	36	11.2 to 21.6
MMY-MAP1806FT8P-E	18	40	12.6 to 24.3
MMY-MAP2006FT8P-E	20	41	14.0 to 25.0*
MMY-AP2216FT8P-E	22	49	15.4 to 29.7
MMY-AP2416FT8P-E	24	54	16.8 to 32.4
MMY-AP2616FT8P-E	26	58	18.2 to 35.1
MMY-AP2816FT8P-E	28	63	19.6 to 37.8
MMY-AP3016FT8P-E	30	64	21.0 to 40.5
MMY-AP3216FT8P-E	32	64	22.4 to 43.2
MMY-AP3416FT8P-E	34	64	23.8 to 45.9
MMY-AP3616FT8P-E	36	64	25.2 to 48.6
MMY-AP3816FT8P-E	38	64	26.6 to 49.4**
MMY-AP4016FT8P-E	40	64	28.0 to 50.0*
MMY-AP4216FT8P-E	42	64	29.4 to 56.7
MMY-AP4416FT8P-E	44	64	30.8 to 59.4
MMY-AP4616FT8P-E	46	64	32.2 to 62.1
MMY-AP4816FT8P-E	48	64	33.6 to 64.8
MMY-AP5016FT8P-E	50	64	35.0 to 67.5
MMY-AP5216FT8P-E	52	64	36.4 to 70.2
MMY-AP5416FT8P-E	54	64	37.8 to 72.9

70 to 135% of outdoor unit capacity

*20,40HP:70 to 125%

**38HP:70 to 130%

2-2-3. Combination ratio between indoor units and outdoor units.

Compared with the capacity code of the outdoor unit, the total value of capacity code of the connectable indoor units differs based on the height difference between the indoor units.

- When the height difference between the indoor units is 15 m or less : 70 to 135 % of outdoor unit capacity
*20,40HP: 70 to 125% , **38HP:70 to 130% of the combination ratio of indoor units to outdoor units
- When the height difference between the indoor units is over 15 m : Up to 70 to 105 % of the combination ratio of indoor units to outdoor units

NOTE:

The case of "Air to Air Heat exchanger with DX-coil" Type is below.

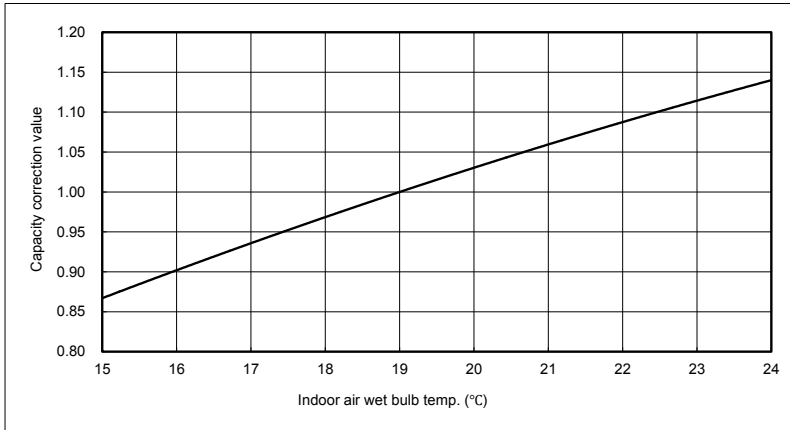
- When the height difference between the indoor units is 15 m or less: Up to 80 to 135 % of the combination ratio of all indoor units to outdoor units
When the height difference between the indoor units is over 15 m: Up to 80 to 105 % of the combination ratio of all indoor units to outdoor units
- Up to 30 % of the internal ratio with total capacity codes of the connecting indoor units
(The connection only of this type with SHRM-i is not allowed.)



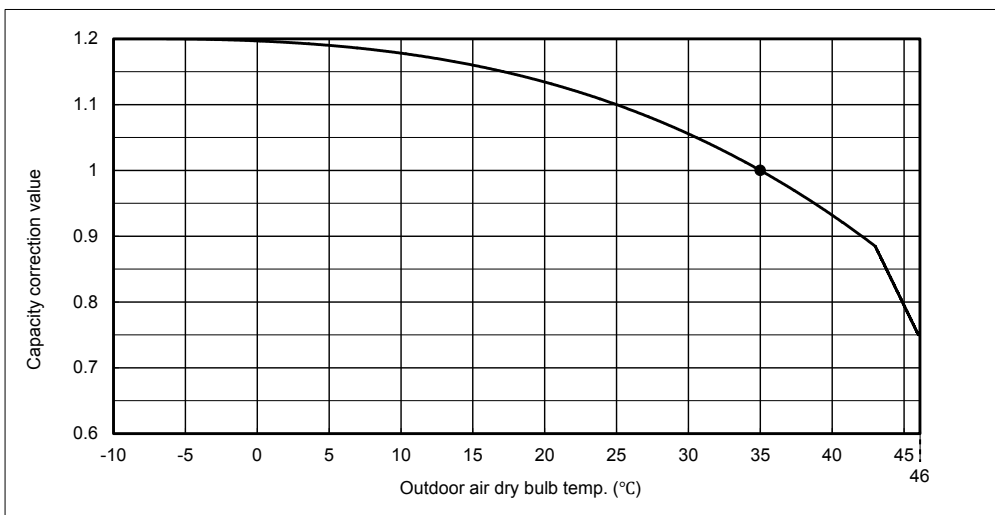
2-3. Cooling/heating capacity characteristics

2-3-1. Correction charts for cooling capacity calculation

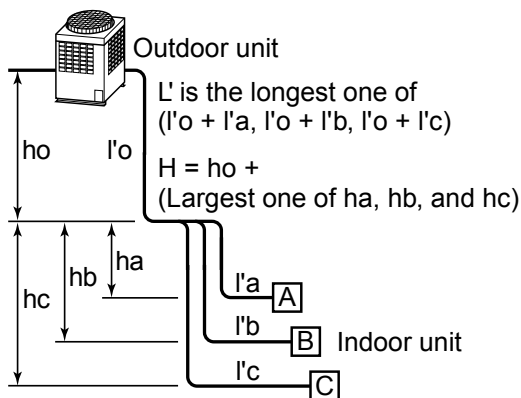
[Chart 1] Indoor air wet bulb temperature vs. capacity correction value



[Chart 2] Outdoor air dry bulb temperature vs. capacity correction value

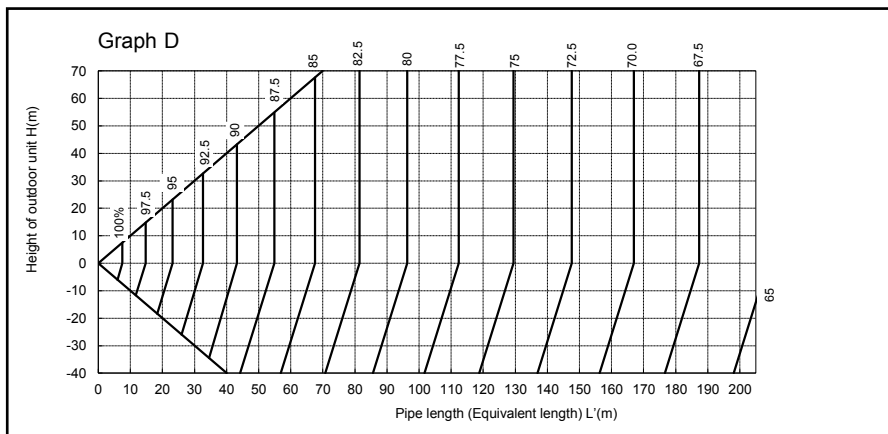
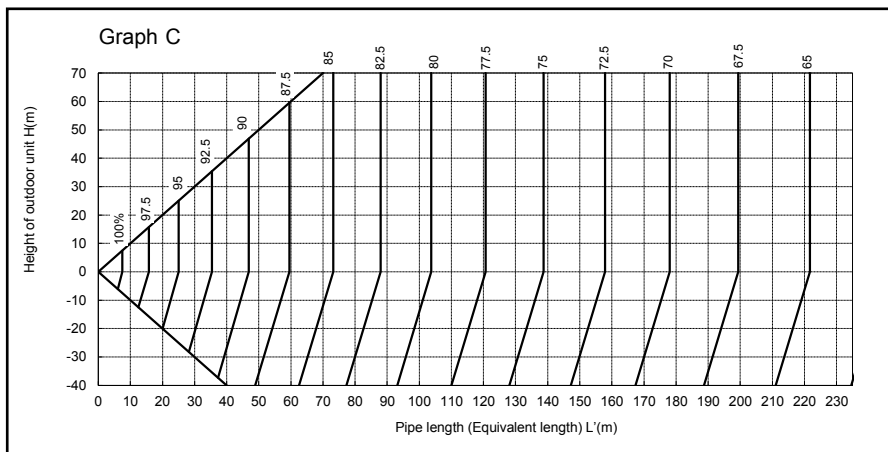
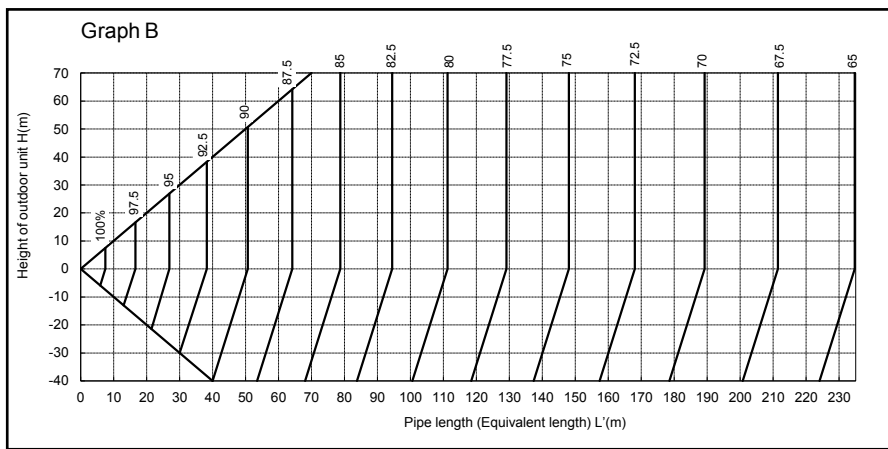
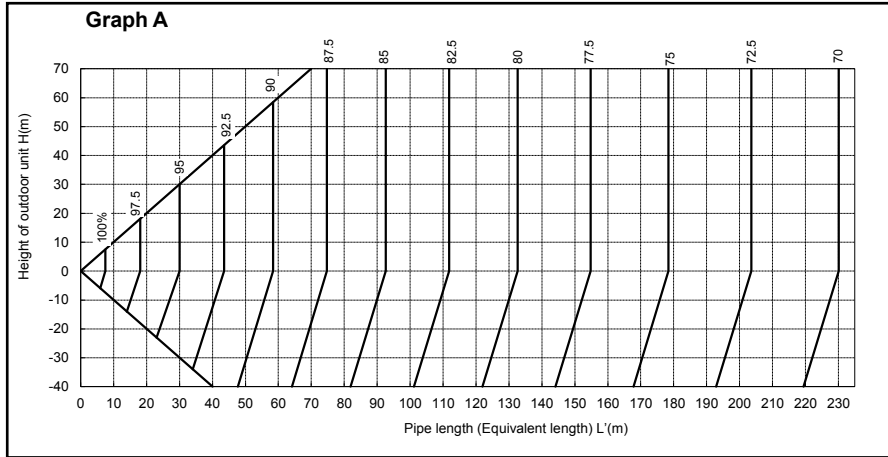


[Chart 3] Connecting pipe length and life difference between indoor and outdoor units vs. capacity correction valve.



HP	Graph	combination	Pipe length (m)
8	B	8	210
10	C	10	210
12	A	12	210
14	A	14	210
16	B	16	210
18	C	18	210
20	C	20	210
22	A	12+10	220
24	A	14+10	220
26	B	14+12	220
28	B	14+14	220
30	B	16+14	220
32	C	18+14	220
34	C	18+16	220
36	A	18+18	220
38	A	20+18	220
40	B	20+20	220
42	D	14+14+14	230
44	D	16+14+14	185
46	D	18+14+14	140
48	D	18+16+14	140
50	D	18+18+14	140
52	D	18+18+16	140
54	D	18+18+18	140

- * 1CDU=210
- * 2CDU=220
- * 3CDU (up to 40HP)=220
- * 3CDU (42HP)=185
- * 3CDU (more than 44HP)=140



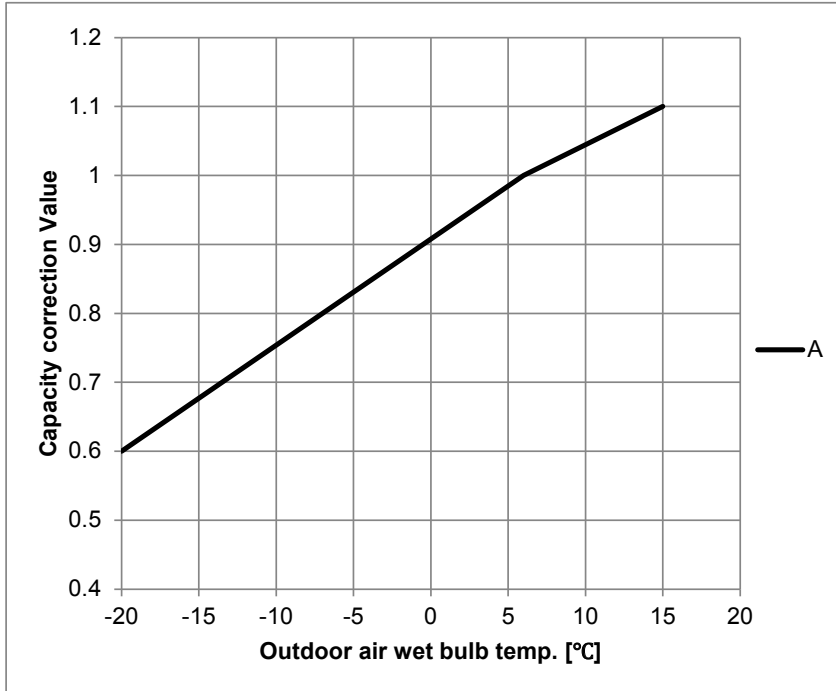


2-3-2. Correction charts for heating capacity calculation

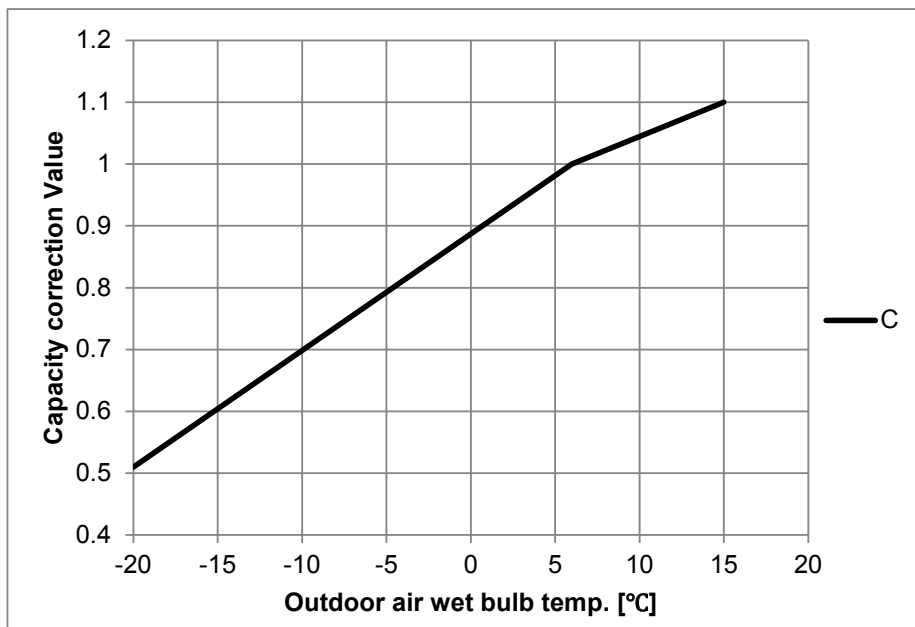
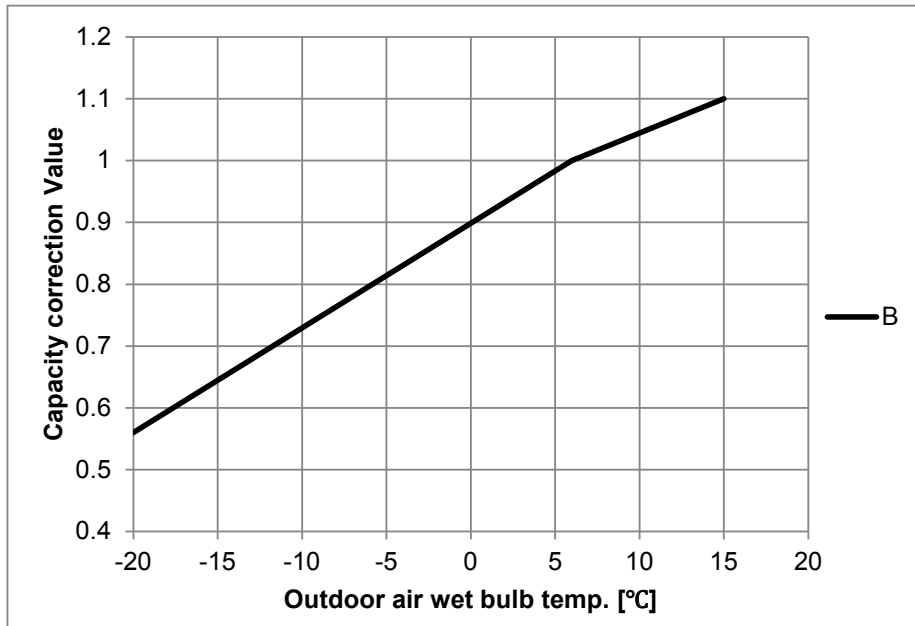
[Chart 1] Indoor air wet bulb temperature vs. capacity correction value



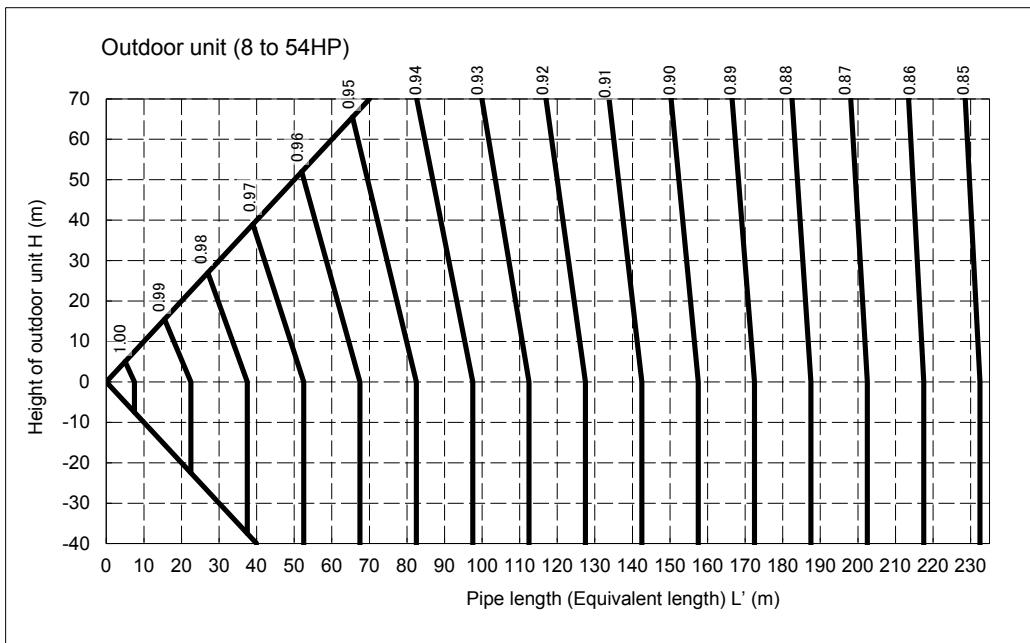
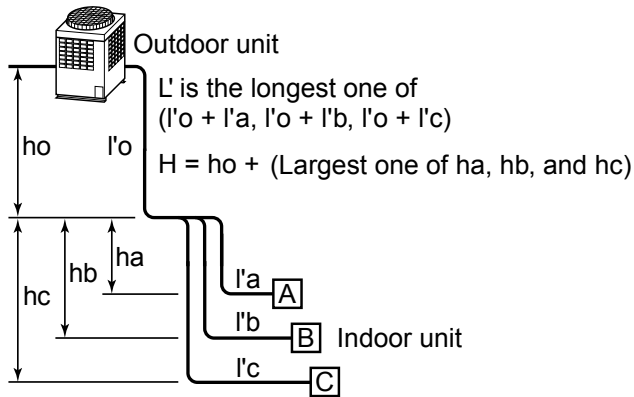
[Chart 2] Outdoor air wet bulb temperature vs. capacity correction value



HP	combination	Graph
8	8	A
10	10	B
12	12	A
14	14	B
16	16	A
18	18	B
20	20	C
22	12+10	B
24	14+10	B
26	14+12	B
28	14+14	B
30	16+14	B
32	18+14	B
34	18+16	B
36	18+18	B
38	20+18	C
40	20+20	C
42	14+14+14	B
44	16+14+14	B
46	18+14+14	B
48	18+16+14	B
50	18+18+14	B
52	18+18+16	B
54	18+18+18	B

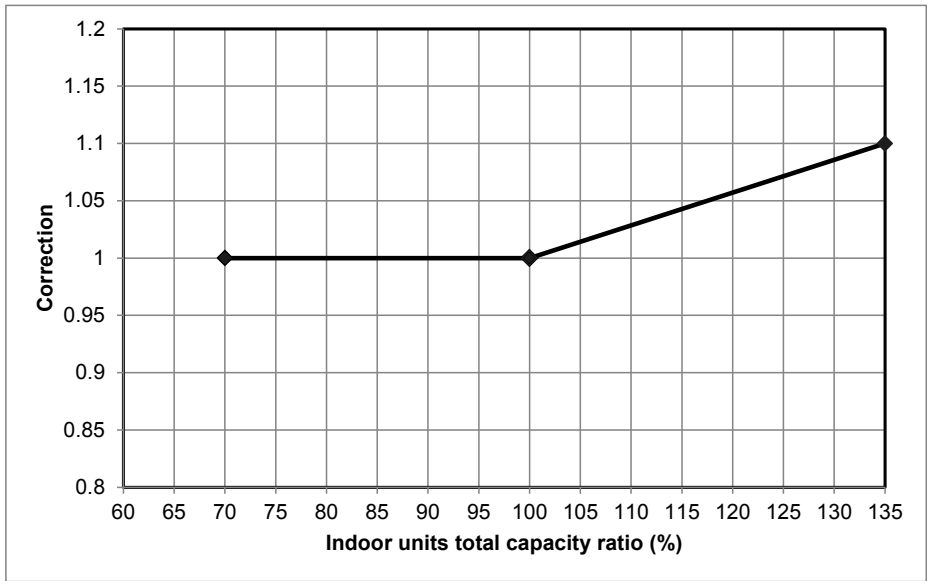


[Chart 3] Connecting pipe length and life difference between indoor and outdoor unit vs. capacity valve





[4]* Correction of outdoor unit diversity



* Coefficient to use for the correction of the outdoor unit capacity when the total capacity of the indoor units are not equal to the outdoor unit capacity.

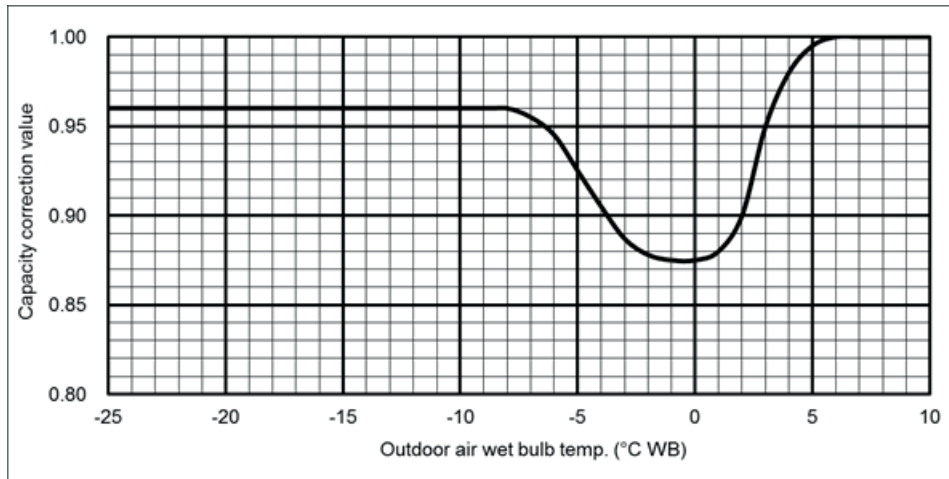


2-3-3. Capacity correction in case of frost on the outdoor heat exchanger when in heating

Correct the heating capacity when frost can be found on the outdoor heat exchanger.

Heating capacity = Capacity after correction of outdoor unit x Correction value of capacity resulted from frost
 (Capacity after correction of outdoor unit: Heating capacity calculated in the above item 2.)

[Chart 5] Capacity correction in case of frost on the outdoor heat exchanger



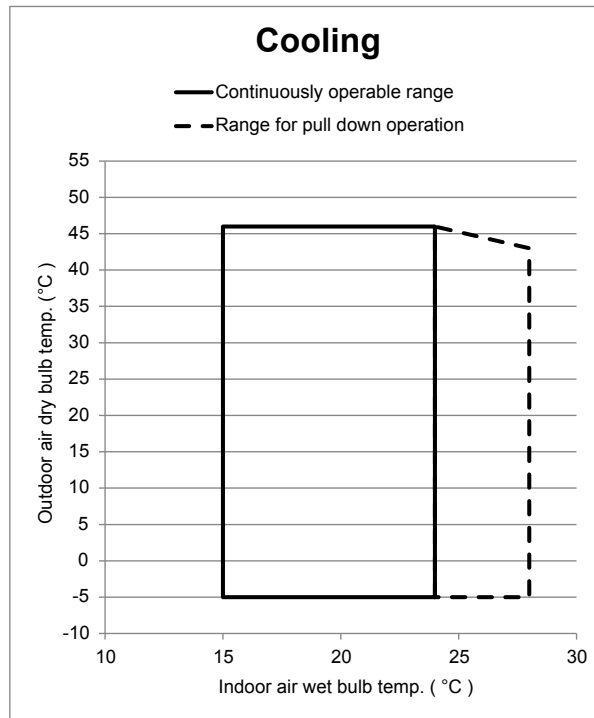
2-3-4. Rated conditions

Cooling: Indoor air temperature 27°C DB/19°C WB, Outdoor air temperature 35°C DB

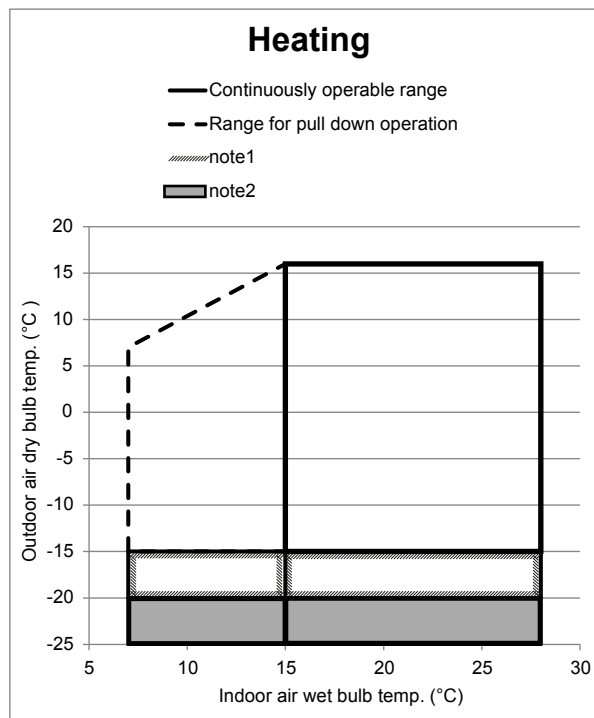
Heating: Indoor air temperature 20°C DB, Outdoor air temperature 7°C DB/6°C WB



2-4. Operational temperature range



Note : The cooling performance may decline considerably when total operating capacity of cooling indoor units is less than 4HP while ambient temperature is below 0 °C.

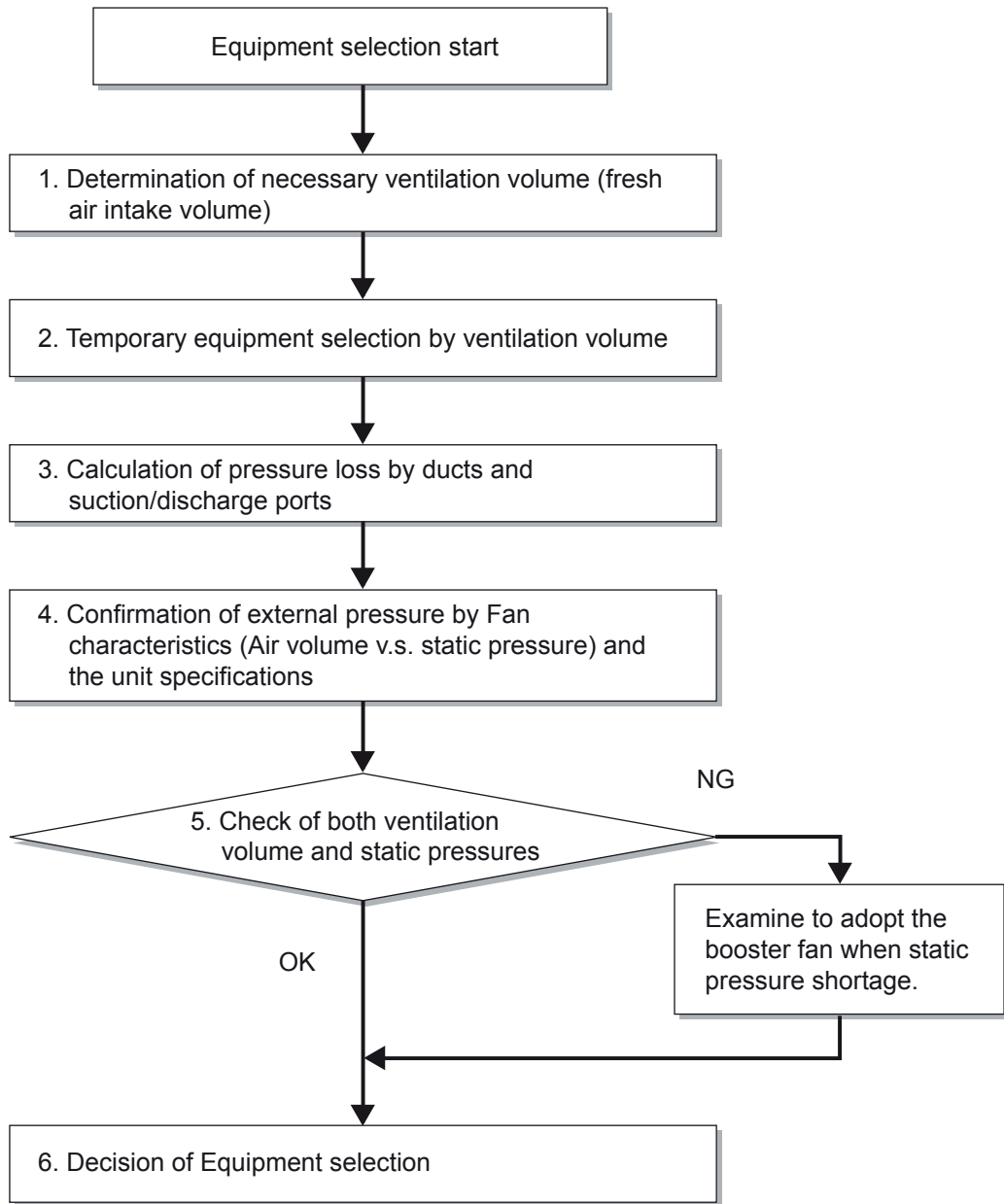


Note1 The unit will operate down to an outdoor temperature of -25°C, however considerable performance decrease will be expected below -15°C. Therefore please consider installation location/surroundings and system design when expected to operate between -15°C and -20°C. Avoid the following place
 Places where ambient temperature falls below -15°C for more than 72 hours running/ The outdoor heat exchanger may be damaged by the frost.

Note2 Low ambient heating (-20°C or less) for extended periods of time is not allowed.

2-5. Selection procedure for Air to Air Heat exchanger with DX-coil Type

2-5-1. Selection flow chart



Note : Air to Air Heat exchanger with DX-coil Type is selected by necessary ventilation volume (fresh air intake volume). And this type operates to bring fresh air close to the room temperature, but is not to control the room temperature. For control of room temperature, it is necessary to set the other air-conditioners.

2-5-2. Example of equipment selection

<Condition>

Necessary ventilation volume : 1000 m³/h

Pressure loss by ducts (including suction/discharge ports) : 100 Pa

<Selection>

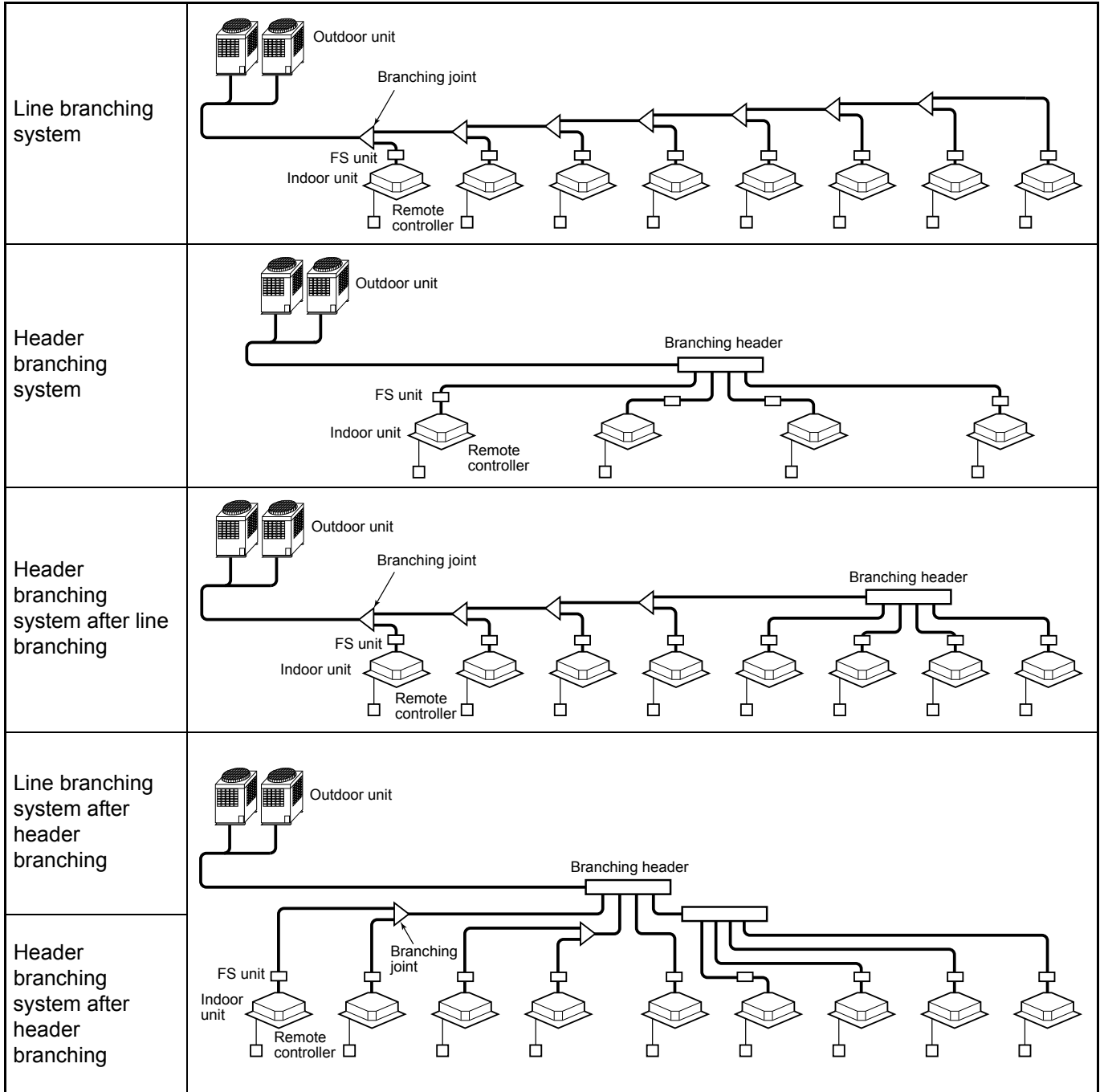
MMD-VN1002HEX1E/MMD-VNK1002HEX1E(High) is selected by the Fan characteristics.



3-1. Free branching system

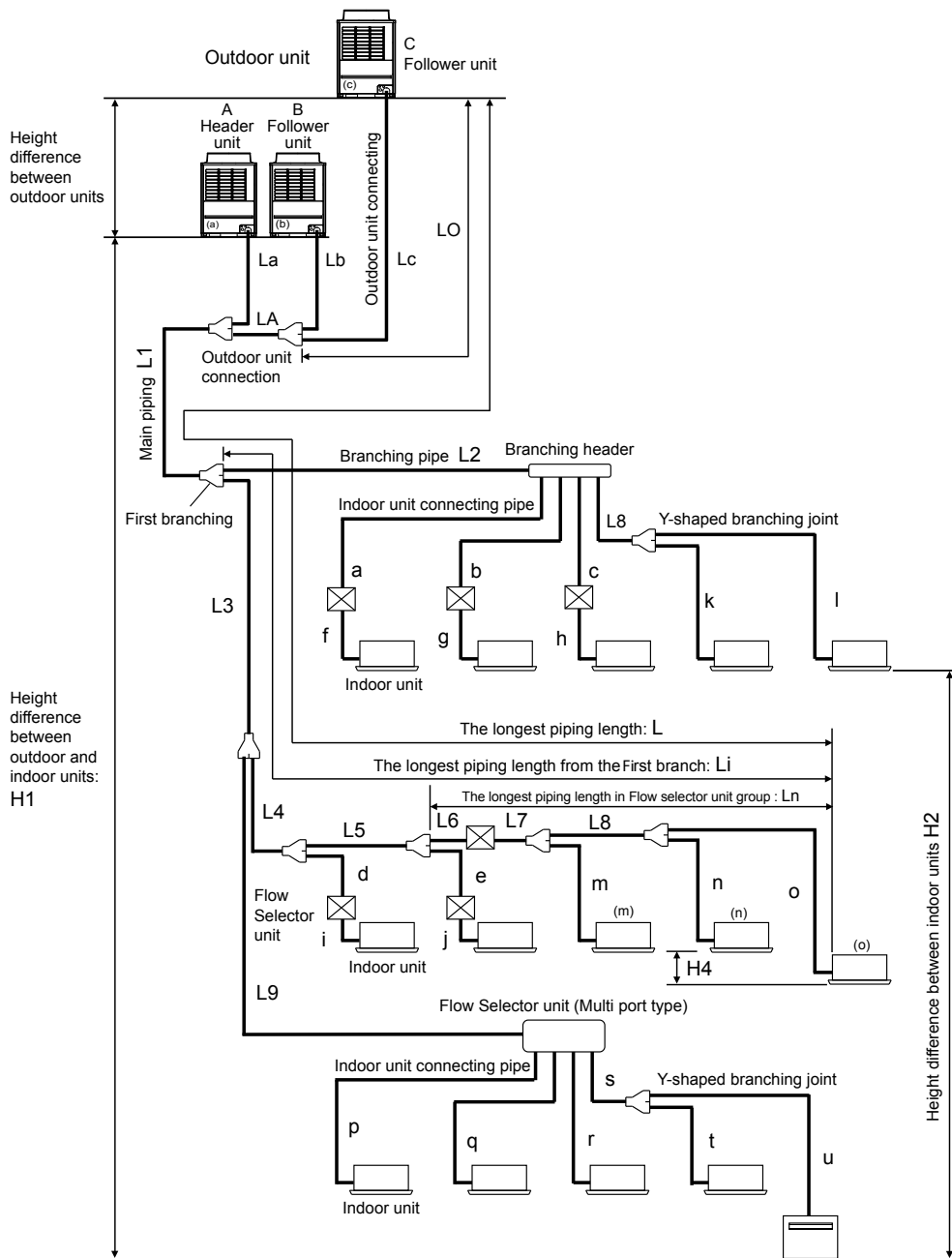
- [1] Line branching system
- [2] Header branching system
- [3] Header branching system after line branching
- [4] Line branching system after header branching
- [5] Header branching system after header branching

The above five branching systems enable to dramatically increase the flexibility of refrigerant piping design.





3-2. Allowable length/height difference of refrigerant piping



◆ System restriction

Outdoor unit combination	Up to 3 units	
Total capacity of outdoor units	Up to 54 HP	
Indoor unit connection	Up to 64 units (*1)	
Total capacity of indoor units (varies depending on the height difference between indoor units.)	$H2 \leq 15m$	135% of outdoor units' capacity (*2)
	$15m < H2$	105% of outdoor units' capacity

(*1) : In case without central control.

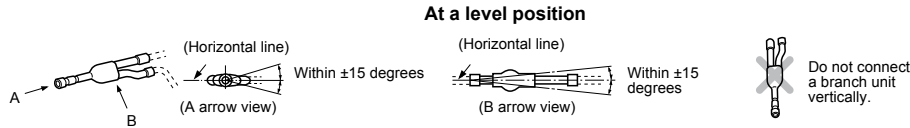
It is up to 54 units in case with central control.

(*2) : MAP200* : 125%, AP381* : 130%, AP401* : 125%

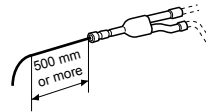
◆ Cautions for installation

Be careful of the connecting arrangement of the header unit and follower units. Set the outdoor units in order of capacity from the one with the largest capacity. (A (Header unit) ≥ B ≥ C ≥ D)

- Be sure to use a header unit for the leading outdoor unit to be connected to the main pipe. (Figure 1 and 3)
- Be sure to use a T-shaped branch joint (RBM-BT14E/RBM-BT24E: separately purchased) to connect each outdoor unit.
- Be careful of the direction of the Outdoor unit connection piping kit for the liquid side. (As shown in Figure 2, a Outdoor unit connection piping kit cannot be attached so that the refrigerant of the main pipe flows directly into the header unit.)
- When attaching a Y-shaped branch unit for the outdoor unit connection piping kit, attach it level with the ground (Be sure not to exceed ±15 degrees.). Regarding a T-shape branch joints for the liquid side, there is no restriction for its angle

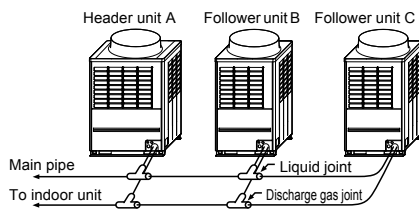


- In case of using the Y-shaped branching joint for connection between outdoor units (Discharge gas joint and Suction gas joint), please keep the straight part of at least 500mm at the inlet.

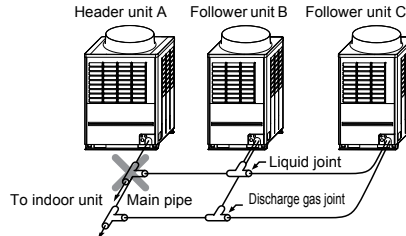


Discharge gas / Liquid pipes

▼ Figure 1



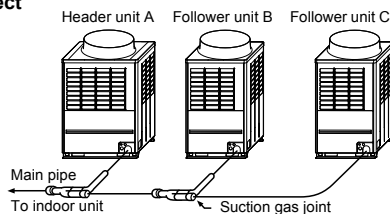
▼ Figure 2



Suction side gas piping

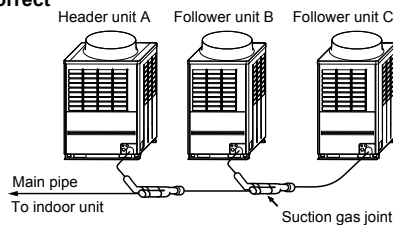
▼ Figure 3

Correct



<Inverse connection suction gas joint>

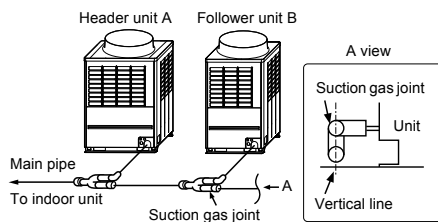
▼ Figure 4
Incorrect



<Upright connection of suction gas joint>

▼ Figure 5

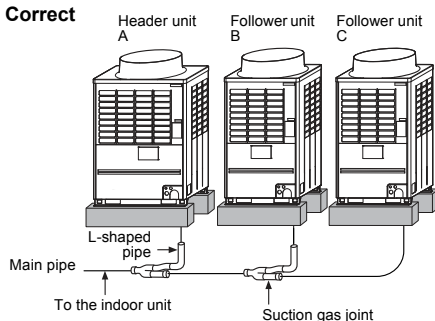
Incorrect



<When drawing pipes downward>

▼ Figure 6

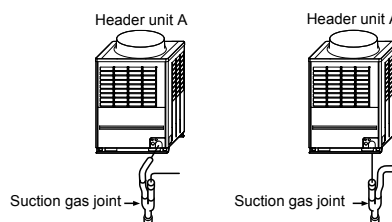
Correct



<Vertical connection of branch units>

▼ Figure 7

Incorrect





◆ Allowable length and allowable height difference of refrigerant piping

Item		Allowable value	Pipes		
Pipe length	Total extension of pipe (liquid pipe, real length)	Less than 34 HP or less	300 m		
		34 HP or more	1000 m (*9)		
	Farthest piping length L (*1) (*3)	Equivalent length	200 m (*2)	LA+Lc+L1+L3+L4+L5+L6+L7+L8+o	
		Real length	180 m		
	Max. equivalent length of Main piping (*12)	H2 > 3 m	Equivalent length	100 m	
			Real length	85 m	
		H2 ≤ 3 m	Equivalent length	120 m	L1
			Real length	100 m	
	Farthest equivalent piping length from the first branch Li (*1)	H2 > 3 m	50 m	L3+L4+L5+L6+L7+L8+o, L3+L9+s+u	
		H2 ≤ 3 m	65 m		
	Farthest equivalent piping length between outdoor units LO (*1)		15 m	LA+Lc (LA+Lb)	
	maximum equivalent piping length of pipes connected to outdoor units		10 m	Lc (La, Lb)	
	Maximum real length of terminal branching section to indoor units		30 m	a+f, b+g, c+h, d+i, e+j, k, l	
Maximum real length of between Flow Selector unit and indoor unit	Single port type	15 m	f, g, h, i, j		
	Multi port type	50 m (*10) (*11)	p, q, r, s+t, s+u		
Maximum equivalent length between branching section		50 m	L2, L3, L4, L8, L9		
Height difference	Height between outdoor and indoor units H1 (*7)	Upper outdoor unit	70m (*8)(*13)		
		Lower outdoor units	30 m (*6)		
	Height between indoor units H2 (*7)	Upper outdoor units	40 m		
		Lower outdoor units (*4)	15 m		
Height between outdoor units H3 (*5)		5 m	-		
<In case of connecting single port type Flow Selector unit and a branch of Multi port type Flow Selector unit to the indoor units.>					
Maximum equivalent length indoor units in group control by one single port Flow Selector unit Ln		30 m	L6+L7+L8+o		
Maximum real length between Flow Selector unit and indoor unit (*2)	Single port type	15 m	(Ex.) In case of wiring to the indoor unit (m): L7+m ≤ 15m In case of wiring to the indoor unit (n): L7+L8+n ≤ 15m		
	Multi port type	50 m	s+t, s+u ≤ 50m		
Height difference between indoor units in group control by one Flow Selector unit H4		0.5 m	-		

*1: Farthest outdoor unit from the first branch: (C), farthest indoor unit: (o)

*2: When connecting the multiple indoor units to the single port type flow selector unit, wire the indoor unit to the remote controller to the single port type flow selection unit.

*3: Allowable values for length equivalent to furthest pipe are shown below and they vary according to performance rank of outdoor unit.

22.4 to 56.0 : 180m, 61.5 to 112:195m, 120:200m.

*4: When system capacity is greater than 28 HP, height difference between indoor units is limited to 3 m. If the piping exceeds 3 m with a capacity greater than 28 HP there may be a case of capacity shortage in cooling.

*5: Ensure that the header unit is installed below all connected follower outdoor unit(s).

Possible product failure may occur if header unit is installed above any follower unit(s).

*6: 40m is possible for a system that uses only the flow selector unit (multi port type), whose all the indoor units are 3HP or higher, and working ambient temperature is 0°C or higher.

*7: As for 44HP to 54HP, contact our agent.

*8: If the height difference (H2) between indoor units exceed 3 m, set 50 m or less.

*9: Total charging refrigerant is 140 kg or less.

*10: The total piping length in one FS unit in case of branching to 4 : 120m (p + q + r + s + t + u), In case of branching to 6 : 180m.

*11: Length of whole pipe should be shorter than 50 m in one branch.

*12: As for 42HP to 54HP, contact our agent.

*13: Extension up till 90m is possible with conditions below

- Outdoor Temperature

Cooling operation : 10 - 46 (DB)

Heating operation : -5 - 15.5 (WB)

Simultaneous operation : 7 - 25 (DB)

- Equivalent length of farthest piping from 1st branching Li < 50m

- Real length of main piping L1 < 100m

- Height difference between indoor units H2 < 3m

- Height difference between FS units < 0.5m

- Total capacity of connectable indoor units : 90% - 100%

- Single CDU, and up to 18HP

- Minimum capacity of connectable indoor : unit 4HP or Larger.



Selection of pipe size

No.	Title	Use Part	Selection of pipe size	Remarks																																													
(1)	Outdoor unit connecting pipe	Outdoor Unit ↓ Outdoor unit connection piping kit	<table border="1"> <thead> <tr> <th>Type</th> <th>Balance pipe side</th> <th>Suction gas side</th> <th>Discharge gas side</th> <th>Liquid side</th> </tr> </thead> <tbody> <tr> <td>MMY-MAP0806*</td> <td>Ø9.5</td> <td>Ø22.2</td> <td>Ø19.1</td> <td>Ø12.7</td> </tr> <tr> <td>MMY-MAP1006*</td> <td>Ø9.5</td> <td>Ø22.2</td> <td>Ø19.1</td> <td>Ø12.7</td> </tr> <tr> <td>MMY-MAP1206*</td> <td>Ø9.5</td> <td>Ø28.6</td> <td>Ø19.1</td> <td>Ø12.7</td> </tr> <tr> <td>MMY-MAP1406*</td> <td>Ø9.5</td> <td>Ø28.6</td> <td>Ø22.2</td> <td>Ø15.9</td> </tr> <tr> <td>MMY-MAP1606*</td> <td>Ø9.5</td> <td>Ø28.6</td> <td>Ø22.2</td> <td>Ø19.1</td> </tr> <tr> <td>MMY-MAP1806*</td> <td>Ø9.5</td> <td>Ø28.6</td> <td>Ø22.2</td> <td>Ø19.1</td> </tr> <tr> <td>MMY-MAP2006*</td> <td>Ø9.5</td> <td>Ø28.6</td> <td>Ø22.2</td> <td>Ø19.1</td> </tr> </tbody> </table>	Type	Balance pipe side	Suction gas side	Discharge gas side	Liquid side	MMY-MAP0806*	Ø9.5	Ø22.2	Ø19.1	Ø12.7	MMY-MAP1006*	Ø9.5	Ø22.2	Ø19.1	Ø12.7	MMY-MAP1206*	Ø9.5	Ø28.6	Ø19.1	Ø12.7	MMY-MAP1406*	Ø9.5	Ø28.6	Ø22.2	Ø15.9	MMY-MAP1606*	Ø9.5	Ø28.6	Ø22.2	Ø19.1	MMY-MAP1806*	Ø9.5	Ø28.6	Ø22.2	Ø19.1	MMY-MAP2006*	Ø9.5	Ø28.6	Ø22.2	Ø19.1						
Type	Balance pipe side	Suction gas side	Discharge gas side	Liquid side																																													
MMY-MAP0806*	Ø9.5	Ø22.2	Ø19.1	Ø12.7																																													
MMY-MAP1006*	Ø9.5	Ø22.2	Ø19.1	Ø12.7																																													
MMY-MAP1206*	Ø9.5	Ø28.6	Ø19.1	Ø12.7																																													
MMY-MAP1406*	Ø9.5	Ø28.6	Ø22.2	Ø15.9																																													
MMY-MAP1606*	Ø9.5	Ø28.6	Ø22.2	Ø19.1																																													
MMY-MAP1806*	Ø9.5	Ø28.6	Ø22.2	Ø19.1																																													
MMY-MAP2006*	Ø9.5	Ø28.6	Ø22.2	Ø19.1																																													
(2)	Between Outdoor unit connecting piping *6	Outdoor unit connection piping kit ↓ Outdoor unit connection piping kit	<table border="1"> <thead> <tr> <th>Total capacity code of outdoor units at the downstream side</th> <th>Suction gas side</th> <th>Discharge gas side</th> <th>Liquid side</th> </tr> </thead> <tbody> <tr> <td>Equivalent to capacity</td> <td>Equivalent to HP</td> <td></td> <td></td> </tr> <tr> <td>45.0 to below 61.5</td> <td>16 to below 22</td> <td>Ø28.6</td> <td>Ø22.2</td> </tr> <tr> <td>61.5 to below 73</td> <td>22 to below 26</td> <td>Ø34.9</td> <td>Ø28.6</td> </tr> <tr> <td>73.0 to below 101.0</td> <td>26 to below 36</td> <td>Ø34.9</td> <td>Ø28.6</td> </tr> <tr> <td>101.0 or more</td> <td>36 or more</td> <td>Ø41.3</td> <td>Ø28.6</td> </tr> </tbody> </table>	Total capacity code of outdoor units at the downstream side	Suction gas side	Discharge gas side	Liquid side	Equivalent to capacity	Equivalent to HP			45.0 to below 61.5	16 to below 22	Ø28.6	Ø22.2	61.5 to below 73	22 to below 26	Ø34.9	Ø28.6	73.0 to below 101.0	26 to below 36	Ø34.9	Ø28.6	101.0 or more	36 or more	Ø41.3	Ø28.6																						
Total capacity code of outdoor units at the downstream side	Suction gas side	Discharge gas side	Liquid side																																														
Equivalent to capacity	Equivalent to HP																																																
45.0 to below 61.5	16 to below 22	Ø28.6	Ø22.2																																														
61.5 to below 73	22 to below 26	Ø34.9	Ø28.6																																														
73.0 to below 101.0	26 to below 36	Ø34.9	Ø28.6																																														
101.0 or more	36 or more	Ø41.3	Ø28.6																																														
(3)	Main piping	Outdoor unit connecting piping kit of header unit ↓ First branching section	<table border="1"> <thead> <tr> <th colspan="2">Total capacity code of all outdoor units</th> <th>Suction gas side</th> <th>Discharge gas side</th> <th>Liquid side</th> </tr> <tr> <th>Equivalent to capacity</th> <th>Equivalent to HP</th> <td></td> <td></td> <td></td> </tr> </thead> <tbody> <tr> <td>22.4 to below 33.5</td> <td>8 to below 12</td> <td>Ø22.2</td> <td>Ø19.1</td> <td>Ø12.7</td> </tr> <tr> <td>33.5 to below 38.4</td> <td>12 to below 14</td> <td>Ø28.6</td> <td>Ø19.1</td> <td>Ø12.7</td> </tr> <tr> <td>38.4 to below 45.0</td> <td>14 to below 16</td> <td>Ø28.6</td> <td>Ø22.2</td> <td>Ø15.8</td> </tr> <tr> <td>45.0 to below 61.5</td> <td>16 to below 22</td> <td>Ø28.6</td> <td>Ø22.2</td> <td>Ø19.1</td> </tr> <tr> <td>61.5 to below 73.0</td> <td>22 to below 26</td> <td>Ø34.9</td> <td>Ø28.6</td> <td>Ø19.1</td> </tr> <tr> <td>73.0 to below 101.0</td> <td>26 to below 36</td> <td>Ø34.9</td> <td>Ø28.6</td> <td>Ø22.2</td> </tr> <tr> <td>101.0 or more</td> <td>36 or more</td> <td>Ø41.3</td> <td>Ø34.9</td> <td>Ø22.2</td> </tr> </tbody> </table>	Total capacity code of all outdoor units		Suction gas side	Discharge gas side	Liquid side	Equivalent to capacity	Equivalent to HP				22.4 to below 33.5	8 to below 12	Ø22.2	Ø19.1	Ø12.7	33.5 to below 38.4	12 to below 14	Ø28.6	Ø19.1	Ø12.7	38.4 to below 45.0	14 to below 16	Ø28.6	Ø22.2	Ø15.8	45.0 to below 61.5	16 to below 22	Ø28.6	Ø22.2	Ø19.1	61.5 to below 73.0	22 to below 26	Ø34.9	Ø28.6	Ø19.1	73.0 to below 101.0	26 to below 36	Ø34.9	Ø28.6	Ø22.2	101.0 or more	36 or more	Ø41.3	Ø34.9	Ø22.2	Pipes side offers based on the total capacity codes of all outdoor units (see table2)
Total capacity code of all outdoor units		Suction gas side	Discharge gas side	Liquid side																																													
Equivalent to capacity	Equivalent to HP																																																
22.4 to below 33.5	8 to below 12	Ø22.2	Ø19.1	Ø12.7																																													
33.5 to below 38.4	12 to below 14	Ø28.6	Ø19.1	Ø12.7																																													
38.4 to below 45.0	14 to below 16	Ø28.6	Ø22.2	Ø15.8																																													
45.0 to below 61.5	16 to below 22	Ø28.6	Ø22.2	Ø19.1																																													
61.5 to below 73.0	22 to below 26	Ø34.9	Ø28.6	Ø19.1																																													
73.0 to below 101.0	26 to below 36	Ø34.9	Ø28.6	Ø22.2																																													
101.0 or more	36 or more	Ø41.3	Ø34.9	Ø22.2																																													
(4)	Branching piping *1, *2, *6	Branching section ↓ Branching section ↓ Branching section ↓ Flow selector unit ↓ Flow selector unit ↓ Branching section	<table border="1"> <thead> <tr> <th colspan="2">Total capacity code of outdoor units of indoor units at the downstream side</th> <th>Suction gas side</th> <th>Discharge gas side</th> <th>Liquid side</th> </tr> <tr> <th>Equivalent to capacity</th> <th>Equivalent to HP</th> <td></td> <td></td> <td></td> </tr> </thead> <tbody> <tr> <td>Below 18</td> <td>Below 6.4</td> <td>Ø15.9</td> <td>Ø12.7</td> <td>Ø9.5</td> </tr> <tr> <td>18 to below 34</td> <td>6.4 to below 12.2</td> <td>Ø22.2</td> <td>Ø19.1</td> <td>Ø12.7</td> </tr> <tr> <td>34 to below 45.5</td> <td>12.2 to below 16.2</td> <td>Ø28.6</td> <td>Ø22.2</td> <td>Ø15.9</td> </tr> <tr> <td>45.5 to below 56.5</td> <td>16.2 to below 20.2</td> <td>Ø28.6</td> <td>Ø22.2</td> <td>Ø19.1</td> </tr> <tr> <td>56.5 to below 70.5</td> <td>20.2 to below 25.2</td> <td>Ø34.9</td> <td>Ø28.6</td> <td>Ø19.1</td> </tr> <tr> <td>70.5 to below 98.5</td> <td>25.2 to below 35.2</td> <td>Ø34.9</td> <td>Ø28.6</td> <td>Ø22.2</td> </tr> <tr> <td>98.5 or more</td> <td>35.2 or more</td> <td>Ø41.3</td> <td>Ø34.9</td> <td>Ø22.2</td> </tr> </tbody> </table>	Total capacity code of outdoor units of indoor units at the downstream side		Suction gas side	Discharge gas side	Liquid side	Equivalent to capacity	Equivalent to HP				Below 18	Below 6.4	Ø15.9	Ø12.7	Ø9.5	18 to below 34	6.4 to below 12.2	Ø22.2	Ø19.1	Ø12.7	34 to below 45.5	12.2 to below 16.2	Ø28.6	Ø22.2	Ø15.9	45.5 to below 56.5	16.2 to below 20.2	Ø28.6	Ø22.2	Ø19.1	56.5 to below 70.5	20.2 to below 25.2	Ø34.9	Ø28.6	Ø19.1	70.5 to below 98.5	25.2 to below 35.2	Ø34.9	Ø28.6	Ø22.2	98.5 or more	35.2 or more	Ø41.3	Ø34.9	Ø22.2	Pipes side offers based on the total capacity code value of indoor units at the downstream side (See Table1 and 2)
Total capacity code of outdoor units of indoor units at the downstream side		Suction gas side	Discharge gas side	Liquid side																																													
Equivalent to capacity	Equivalent to HP																																																
Below 18	Below 6.4	Ø15.9	Ø12.7	Ø9.5																																													
18 to below 34	6.4 to below 12.2	Ø22.2	Ø19.1	Ø12.7																																													
34 to below 45.5	12.2 to below 16.2	Ø28.6	Ø22.2	Ø15.9																																													
45.5 to below 56.5	16.2 to below 20.2	Ø28.6	Ø22.2	Ø19.1																																													
56.5 to below 70.5	20.2 to below 25.2	Ø34.9	Ø28.6	Ø19.1																																													
70.5 to below 98.5	25.2 to below 35.2	Ø34.9	Ø28.6	Ø22.2																																													
98.5 or more	35.2 or more	Ø41.3	Ø34.9	Ø22.2																																													
(5)	Indoor unit connecting pipe	Flow selector unit ↓ Indoor unit	<table border="1"> <thead> <tr> <th>Capacity rank</th> <th>Equivalent to capacity</th> <th>Gas side</th> <th>Liquid side</th> </tr> </thead> <tbody> <tr> <td>005 to 012</td> <td>0.8 to 1.25</td> <td>Ø9.5</td> <td>Ø5.4</td> </tr> <tr> <td>015 to 018</td> <td>1.7 to 2.0</td> <td>Ø12.7</td> <td>Ø5.4</td> </tr> <tr> <td>024 to 056</td> <td>2.5 to 6.0</td> <td>Ø15.9</td> <td>Ø9.5</td> </tr> <tr> <td>072 to 096</td> <td>8.0 to 10.0</td> <td>Ø22.2</td> <td>Ø12.7</td> </tr> </tbody> </table>	Capacity rank	Equivalent to capacity	Gas side	Liquid side	005 to 012	0.8 to 1.25	Ø9.5	Ø5.4	015 to 018	1.7 to 2.0	Ø12.7	Ø5.4	024 to 056	2.5 to 6.0	Ø15.9	Ø9.5	072 to 096	8.0 to 10.0	Ø22.2	Ø12.7																										
Capacity rank	Equivalent to capacity	Gas side	Liquid side																																														
005 to 012	0.8 to 1.25	Ø9.5	Ø5.4																																														
015 to 018	1.7 to 2.0	Ø12.7	Ø5.4																																														
024 to 056	2.5 to 6.0	Ø15.9	Ø9.5																																														
072 to 096	8.0 to 10.0	Ø22.2	Ø12.7																																														
(6)	Indoor unit connecting pipe	Terminal branching section ↓ Indoor unit	<table border="1"> <thead> <tr> <th>Capacity rank</th> <th>Equivalent to HP</th> <th>Length og piping</th> <th>Gas side</th> <th>Liquid side</th> </tr> </thead> <tbody> <tr> <td rowspan="2">005 to 012</td> <td rowspan="2">0.5 to 1.25</td> <td>15 m or less real length</td> <td>Ø9.5</td> <td>Ø6.4</td> </tr> <tr> <td>Exceeds 15m real length</td> <td>Ø12.7</td> <td>Ø9.5</td> </tr> <tr> <td rowspan="2">015 to 018</td> <td rowspan="2">1.7 tp 2.0</td> <td>15 m or less real length</td> <td>Ø12.7</td> <td>Ø6.4</td> </tr> <tr> <td>Exceeds 15m real length</td> <td>Ø15.9</td> <td>Ø9.5</td> </tr> <tr> <td>024 to 056</td> <td>2.5 to 6.0</td> <td>-</td> <td>Ø15.9</td> <td>Ø9.5</td> </tr> <tr> <td>072 to 096</td> <td>8.0 to 10.0</td> <td>-</td> <td>Ø22.2</td> <td>Ø12.7</td> </tr> </tbody> </table>	Capacity rank	Equivalent to HP	Length og piping	Gas side	Liquid side	005 to 012	0.5 to 1.25	15 m or less real length	Ø9.5	Ø6.4	Exceeds 15m real length	Ø12.7	Ø9.5	015 to 018	1.7 tp 2.0	15 m or less real length	Ø12.7	Ø6.4	Exceeds 15m real length	Ø15.9	Ø9.5	024 to 056	2.5 to 6.0	-	Ø15.9	Ø9.5	072 to 096	8.0 to 10.0	-	Ø22.2	Ø12.7															
Capacity rank	Equivalent to HP	Length og piping	Gas side	Liquid side																																													
005 to 012	0.5 to 1.25	15 m or less real length	Ø9.5	Ø6.4																																													
		Exceeds 15m real length	Ø12.7	Ø9.5																																													
015 to 018	1.7 tp 2.0	15 m or less real length	Ø12.7	Ø6.4																																													
		Exceeds 15m real length	Ø15.9	Ø9.5																																													
024 to 056	2.5 to 6.0	-	Ø15.9	Ø9.5																																													
072 to 096	8.0 to 10.0	-	Ø22.2	Ø12.7																																													
(7)	Y-shaped branhing joint *3, *4	Branching section	<table border="1"> <thead> <tr> <th colspan="2">Total capacity code of indoor units</th> <th colspan="2">Model name</th> </tr> <tr> <th>Equivalent to capacity</th> <th>Equivalent to HP</th> <th>For 3 piping</th> <th>For 2 piping</th> </tr> </thead> <tbody> <tr> <td>Below 18.0</td> <td>Below 6.4</td> <td>RBM-BY55FE</td> <td>RBM-BY55E</td> </tr> <tr> <td>18.0 to below 40.0</td> <td>6.4 to below 14.2</td> <td>RBM-BY105FE</td> <td>RBM-BY105E</td> </tr> <tr> <td>40.0 to below 70.5</td> <td>14.2 to below 25.2</td> <td>RBM-BY205FE</td> <td>RBM-BY205E</td> </tr> <tr> <td>70.5 or more</td> <td>25.2 or more</td> <td>RBM-BY305FE</td> <td>RBM-BY305E</td> </tr> </tbody> </table>	Total capacity code of indoor units		Model name		Equivalent to capacity	Equivalent to HP	For 3 piping	For 2 piping	Below 18.0	Below 6.4	RBM-BY55FE	RBM-BY55E	18.0 to below 40.0	6.4 to below 14.2	RBM-BY105FE	RBM-BY105E	40.0 to below 70.5	14.2 to below 25.2	RBM-BY205FE	RBM-BY205E	70.5 or more	25.2 or more	RBM-BY305FE	RBM-BY305E																						
Total capacity code of indoor units		Model name																																															
Equivalent to capacity	Equivalent to HP	For 3 piping	For 2 piping																																														
Below 18.0	Below 6.4	RBM-BY55FE	RBM-BY55E																																														
18.0 to below 40.0	6.4 to below 14.2	RBM-BY105FE	RBM-BY105E																																														
40.0 to below 70.5	14.2 to below 25.2	RBM-BY205FE	RBM-BY205E																																														
70.5 or more	25.2 or more	RBM-BY305FE	RBM-BY305E																																														
(8)	Branching header *3, *4, *5	Branching section	<table border="1"> <thead> <tr> <th rowspan="2"></th> <th colspan="2">Total capacity code of indoor units</th> <th colspan="2">Model name</th> </tr> <tr> <th>Equivalent to capacity</th> <th>Equivalent to HP</th> <th>For 3 piping</th> <th>For 2 piping</th> </tr> </thead> <tbody> <tr> <td rowspan="2">For 4 branches</td> <td>Below 40.0</td> <td>Below 14.2</td> <td>RBM-HY1043FE</td> <td>RBM-HY1043E</td> </tr> <tr> <td>40.0 to below 70.5</td> <td>14.2 to below 25.2</td> <td>RBM-HY2043FE</td> <td>RBM-HY2043E</td> </tr> <tr> <td rowspan="2">For 8 branches</td> <td>Below 40.0</td> <td>Below 14.2</td> <td>RBM-HY1083FE</td> <td>RBM-HY1083E</td> </tr> <tr> <td>40.0 to below 70.5</td> <td>14.2 to below 25.2</td> <td>RBM-HY2083FE</td> <td>RBM-HY2083E</td> </tr> </tbody> </table>		Total capacity code of indoor units		Model name		Equivalent to capacity	Equivalent to HP	For 3 piping	For 2 piping	For 4 branches	Below 40.0	Below 14.2	RBM-HY1043FE	RBM-HY1043E	40.0 to below 70.5	14.2 to below 25.2	RBM-HY2043FE	RBM-HY2043E	For 8 branches	Below 40.0	Below 14.2	RBM-HY1083FE	RBM-HY1083E	40.0 to below 70.5	14.2 to below 25.2	RBM-HY2083FE	RBM-HY2083E																			
	Total capacity code of indoor units		Model name																																														
	Equivalent to capacity	Equivalent to HP	For 3 piping	For 2 piping																																													
For 4 branches	Below 40.0	Below 14.2	RBM-HY1043FE	RBM-HY1043E																																													
	40.0 to below 70.5	14.2 to below 25.2	RBM-HY2043FE	RBM-HY2043E																																													
For 8 branches	Below 40.0	Below 14.2	RBM-HY1083FE	RBM-HY1083E																																													
	40.0 to below 70.5	14.2 to below 25.2	RBM-HY2083FE	RBM-HY2083E																																													
(9)	Outdoor unit connection piping kit *6	Branching section	<table border="1"> <thead> <tr> <th colspan="2">Total capacity codes of outdoor units at the downstream side</th> <th>Model name</th> </tr> <tr> <th>Equivalent to capacity</th> <th>Equivalent to HP</th> <td></td> </tr> </thead> <tbody> <tr> <td>Below 73.0</td> <td>Below 26.0</td> <td>RBM-BT14FE</td> </tr> <tr> <td>73.0 or more</td> <td>26.0 or more</td> <td>RBM-BT24FE</td> </tr> </tbody> </table>	Total capacity codes of outdoor units at the downstream side		Model name	Equivalent to capacity	Equivalent to HP		Below 73.0	Below 26.0	RBM-BT14FE	73.0 or more	26.0 or more	RBM-BT24FE																																		
Total capacity codes of outdoor units at the downstream side		Model name																																															
Equivalent to capacity	Equivalent to HP																																																
Below 73.0	Below 26.0	RBM-BT14FE																																															
73.0 or more	26.0 or more	RBM-BT24FE																																															
(10)	Flow Selector unit *7	Flow Selector unit ↓ Indoor unit	<table border="1"> <thead> <tr> <th colspan="4">Single port type</th> </tr> <tr> <th colspan="3">Total capacity codes of connected indoor units</th> <th>Model name</th> </tr> <tr> <th>Equivalent to capacity</th> <th>Equivalent to HP</th> <th>Max No. of connected indoor unit</th> <td></td> </tr> </thead> <tbody> <tr> <td>Below 11.2</td> <td>Below 4.0</td> <td>Below 5</td> <td>RBM-Y1123FE*</td> </tr> <tr> <td>11.2 to below 18.0</td> <td>4.0 to below 6.4</td> <td>Below 10</td> <td>RBM-Y1803FE*</td> </tr> <tr> <td>18.0 to 28.0 or less</td> <td>6.4 to below 10.0</td> <td>Below 10</td> <td>RBM-Y2803FE*</td> </tr> <tr> <th colspan="4">Multi port type</th> </tr> <tr> <th>Equivalent to capacity</th> <th>Equivalent to HP</th> <th>Max No. of connected indoor unit in a branch</th> <th>No. of branch</th> </tr> <tr> <td rowspan="2">Below 18.0</td> <td rowspan="2">Below 6.4</td> <td rowspan="2">10</td> <td>4</td> </tr> <tr> <td>5</td> </tr> </tbody> </table>	Single port type				Total capacity codes of connected indoor units			Model name	Equivalent to capacity	Equivalent to HP	Max No. of connected indoor unit		Below 11.2	Below 4.0	Below 5	RBM-Y1123FE*	11.2 to below 18.0	4.0 to below 6.4	Below 10	RBM-Y1803FE*	18.0 to 28.0 or less	6.4 to below 10.0	Below 10	RBM-Y2803FE*	Multi port type				Equivalent to capacity	Equivalent to HP	Max No. of connected indoor unit in a branch	No. of branch	Below 18.0	Below 6.4	10	4	5									
Single port type																																																	
Total capacity codes of connected indoor units			Model name																																														
Equivalent to capacity	Equivalent to HP	Max No. of connected indoor unit																																															
Below 11.2	Below 4.0	Below 5	RBM-Y1123FE*																																														
11.2 to below 18.0	4.0 to below 6.4	Below 10	RBM-Y1803FE*																																														
18.0 to 28.0 or less	6.4 to below 10.0	Below 10	RBM-Y2803FE*																																														
Multi port type																																																	
Equivalent to capacity	Equivalent to HP	Max No. of connected indoor unit in a branch	No. of branch																																														
Below 18.0	Below 6.4	10	4																																														
			5																																														

*1 : Use the same size as the main pipe if it is larger than the main pipe.

*2 : use a suction gas pipe and a liquid pipe for the two pipe branching downstream from the flow selector unit and the dedicated cooling circuit.

*3 : Select the branch pipe of the first branch according to the outdoor capacity code.

*4 : Select according to the outdoor unit capacity code if the total of the indoor capacity codes exceeds the outdoor unit capacity code.

*5 : It is possible to select up to a maximum capacity code total AP056 (6hp) for the first circuit after the header branch.

When using a branch header for the first branch with an outdoor unit capacity code of 33.5 (12 hp equivalent) or more and 73.0 (26 hp equivalent) or less, use RBM-HY2043FE (4 branches) and RBM-HY2083FE (8 branches) regardless of the total value of the capacity codes of the downstream indoor units.

And, a branch header cannot be used as the first branch if the performance rank is over 73.0 (26hp equivalent).

*6 : The downstream strating point is the main pipe.

*7 : If the performance rank is over 117.5 (42 Hp equivalent), "Flow Selector unit" is available for only Multi port side.



3-4. Charging requirement with additional refrigerant

Calculating the amount of additional refrigerant required

Refrigerant in the system when shipped from the factory

		8HP	10HP	12HP	14HP	16HP	18HP	20HP
Refrigerant amount charged in factory	Heat recovery model	11.0 kg	11.0 kg	11.0 kg	11.0 kg	11.0 kg	11.0 kg	11.0 kg

When the system is charged with refrigerant at the factory, the amount of refrigerant needed for the pipes at the site is not included. Therefore, calculate the additional amount needed and add the required amount to the system.

(Calculation)

Additional refrigerant charge amount is calculated based on the size of liquid pipe at site and its real length.

$$[\text{Additional refrigerant charge amount at site}] =$$

$$[\text{Real length of liquid pipe}] \times \left[\frac{\text{Additional refrigerant charge amount}}{\text{per liquid pipe 1 m (Table 1)}} \right] \times 1.3 + \left[\frac{\text{Compensation by system HP (Table 2)}}{\text{system HP (Table 2)}} \right]$$

Example : Additional charge amount R (kg) = $\{(L1 \times 0.025 \text{ kg/m}) + (L2 \times 0.055 \text{ kg/m}) + (L3 \times 0.105 \text{ kg/m}) + (L4 \times 0.160 \text{ kg/m}) + (L5 \times 0.250 \text{ kg/m})\} \times 1.3 + (14 \text{ kg})$

- L1 : Real total length of liquid pipe ø6.4 (m)
- L2 : Real total length of liquid pipe ø9.5 (m)
- L3 : Real total length of liquid pipe ø12.7 (m)
- L4 : Real total length of liquid pipe ø15.9 (m)
- L5 : Real total length of liquid pipe ø19.1 (m)
- System : 30HP

Table 1

Pipe dia. at liquid side	ø6.4	ø9.5	ø12.7	ø15.9	ø19.1	ø22.2
Additional refrigerant amount / 1 m	0.025 kg	0.055 kg	0.105 kg	0.160 kg	0.250 kg	0.350 kg

Table 2 (SHRM-e)

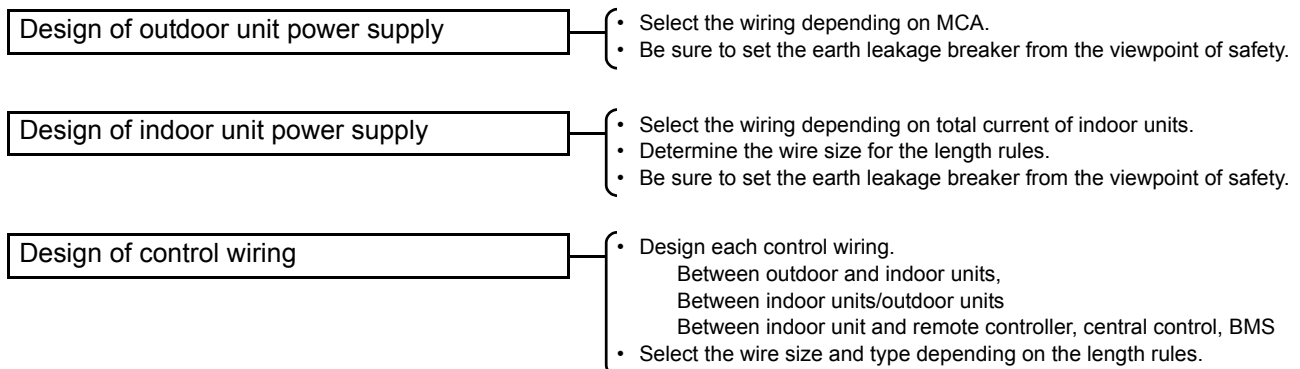
Combinated horse power (HP)	Outdoor combination (HP)			Compensation by system HP (kg)
8	8			2
10	10			3
12	12			8
14	14			10
16	16			12
18	18			14
20	20			15
22	12	10		6
24	14	10		8
26	14	12		12
28	14	14		12
30	16	14		14
32	16	16		15
34	18	16		16
36	18	18		18
38	20	18		22
40	20	20		24
42	14	14	14	14
44	16	14	14	15
46	18	14	14	16
48	16	16	16	17
50	18	16	16	18
52	18	18	16	20
54	18	18	18	22



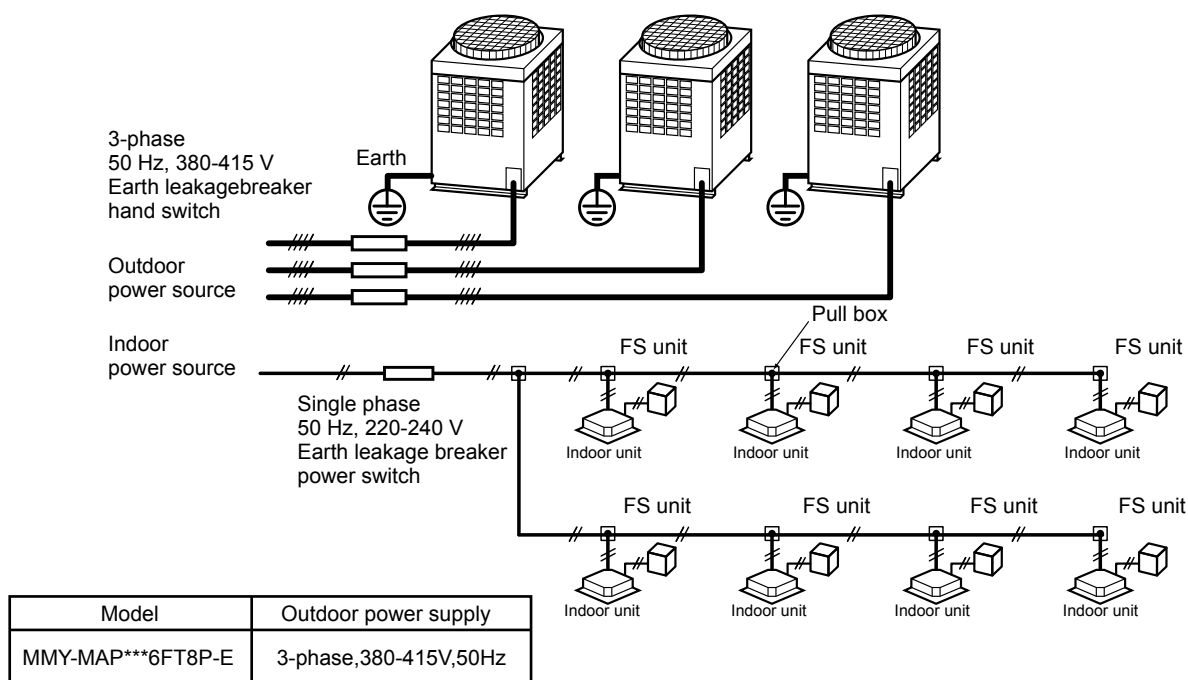
4-1.General

- Perform wiring of the power supply in conformance with the regulations of the local electric company.
- For cabling of the power supply of the indoor unit and the inter-unit cabling between indoor and outdoor units, refer to the Installation Manual of indoor unit.
- Never connect power supply to the terminal block (U1, U2, U3, U4, U5, U6) for control wiring.
(The equipment breaks down.)
- Arrange the cables so that the electric wires do not come to contact with high-temperature part of the pipe; otherwise coating melts and an accident may be caused.
- After connecting cable to the terminal block, take off the trap and then fix the cable with cable clamp.
- Do not turn on power of the indoor unit until vacuuming of the refrigerant pipe will finish.

4-2.Summary of wiring design



4-3.Electrical wiring design



NOTE:

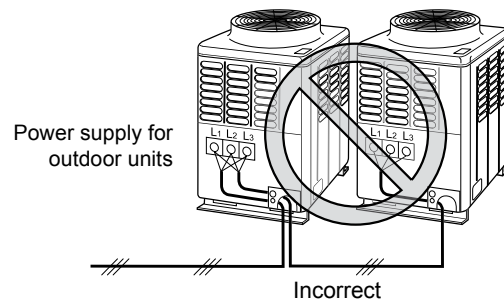
Control wire and power supply wire between the FS unit and the indoor unit are supplied as an accessory complete with the FS unit. (Wire length : 6 m) ※Except Multi ports FS unit
If the length between indoor and FS unit exceeds 5 m, connect by using the connection cable kit sold separately (RBC-CBK15FE).



4-4. Outdoor unit power supply

- Select the power supply cabling and fuse of each outdoor unit from the following specifications: cable 4-core, in conformance with Design 60245 IEC 66
- Do not connect the outdoor units by crossing outside of them, but connect them via the terminal block (L1, L2, L3, N).

Every outdoor unit must have a dedicated power supply.



Model	Outdoor power supply
MMY-MAP***6FT8P-E	3-phase,380-415V,50Hz

Outdoor unit data

[50Hz,380/400/415V]

■ Single outdoor unit

HP	Heat Recovery Model MMY-	Power Supply		Voltage Range		Output			MCA	MOCP	
						Compressor					Fan Motor
		Phase and frequency	Nominal Voltage	Min (V)	Max (V)	Unit No.1 (kW)	Unit No.2 (kW)	Unit No.3 (kW)			
8	MAP0806FT8P-E	3N~ 50Hz	380-400-415V	342	456	2.3x2			1.0	21.5	25
10	MAP1006FT8P-E	3N~ 50Hz	380-400-415V	342	456	3.1x2			1.0	26.1	32
12	MAP1206FT8P-E	3N~ 50Hz	380-400-415V	342	456	3.9x2			1.0	31.0	40
14	MAP1406FT8P-E	3N~ 50Hz	380-400-415V	342	456	4.8x2			1.0	35.8	50
16	MAP1606FT8P-E	3N~ 50Hz	380-400-415V	342	456	5.8x2			2.0	40.7	50
18	MAP1806FT8P-E	3N~ 50Hz	380-400-415V	342	456	6.5x2			2.0	44.9	50
20	MAP2006FT8P-E	3N~ 50Hz	380-400-415V	342	456	7.6x2			2.0	49.3	63

■ Combination of outdoor unit

HP	Heat Recovery Model MMY-	Power Supply		Voltage Range		Output			MCA	MOCP	
						Compressor					Fan Motor
		Phase and frequency	Nominal Voltage	Min (V)	Max (V)	Unit No.1 (kW)	Unit No.2 (kW)	Unit No.3 (kW)			
22	AP2216FT8P-E	3N~ 50Hz	380-400-415V	342	456	3.9x2	3.1x2		1.0+1.0	57.1	63
24	AP2416FT8P-E	3N~ 50Hz	380-400-415V	342	456	3.9x2	3.9x2		1.0+1.0	62.0	80
26	AP2616FT8P-E	3N~ 50Hz	380-400-415V	342	456	4.8x2	3.9x2		1.0+1.0	66.8	80
28	AP2816FT8P-E	3N~ 50Hz	380-400-415V	342	456	4.8x2	4.8x2		1.0+1.0	71.6	80
30	AP3016FT8P-E	3N~ 50Hz	380-400-415V	342	456	5.8x2	4.8x2		2.0+1.0	76.5	100
32	AP3216FT8P-E	3N~ 50Hz	380-400-415V	342	456	5.8x2	5.8x2		2.0+2.0	81.3	100
34	AP3416FT8P-E	3N~ 50Hz	380-400-415V	342	456	6.5x2	5.8x2		2.0+2.0	85.6	100
36	AP3616FT8P-E	3N~ 50Hz	380-400-415V	342	456	6.5x2	6.5x2		2.0+2.0	89.8	100
38	AP3816FT8P-E	3N~ 50Hz	380-400-415V	342	456	7.6x2	6.5x2		2.0+2.0	94.2	125
40	AP4016FT8P-E	3N~ 50Hz	380-400-415V	342	456	7.6x2	7.6x2		2.0+2.0	98.6	125
42	AP4216FT8P-E	3N~ 50Hz	380-400-415V	342	456	4.8x2	4.8x2	4.8x2	1.0+1.0+1.0	107.4	125
44	AP4416FT8P-E	3N~ 50Hz	380-400-415V	342	456	5.8x2	4.8x2	4.8x2	2.0+1.0+1.0	112.3	125
46	AP4616FT8P-E	3N~ 50Hz	380-400-415V	342	456	6.5x2	4.8x2	4.8x2	2.0+1.0+1.0	116.5	160
48	AP4816FT8P-E	3N~ 50Hz	380-400-415V	342	456	5.8x2	5.8x2	5.8x2	2.0+2.0+2.0	122.0	160
50	AP5016FT8P-E	3N~ 50Hz	380-400-415V	342	456	6.5x2	5.8x2	5.8x2	2.0+2.0+2.0	126.2	160
52	AP5216FT8P-E	3N~ 50Hz	380-400-415V	342	456	6.5x2	6.5x2	5.8x2	2.0+2.0+2.0	130.5	160
54	AP5416FT8P-E	3N~ 50Hz	380-400-415V	342	456	6.5x2	6.5x2	6.5x2	2.0+2.0+2.0	134.7	160

Notes MCA :Minimum Circuit Amps
MOCP :Maximum Overcurrent Protection(Amps)



4-5. Indoor unit power supply

Electrical characteristics for 50 Hz outdoor units

Type	Model name	Capacity rank	Capacity Code	Cooling capacity(kW)	Heating capacity(kW)	Nominal Voltage (V-Ph-Hz)	Voltage Range		Fan Motor		Power Supply	
							Min	Max	kW	FLA	MCA	MOCP
4-way Air Discharge Cassette Type	MMU-AP0094HP1-E	009	1	2.8	3.2	230-150	198	264	0.014	0.63	0.79	15
	MMU-AP0124HP1-E	012	1.25	3.6	4.0	230-150	198	264	0.014	0.63	0.79	15
	MMU-AP0154HP1-E	015	1.7	4.5	5.0	230-150	198	264	0.014	0.80	1.00	15
	MMU-AP0184HP1-E	018	2	5.6	6.3	230-150	198	264	0.014	0.80	1.00	15
	MMU-AP0244HP1-E	024	2.5	7.1	8.0	230-150	198	264	0.020	0.87	1.09	15
	MMU-AP0274HP1-E	027	3.0	8.0	9.0	230-150	198	264	0.020	0.87	1.09	15
	MMU-AP0304HP1-E	030	3.2	9.0	10.0	230-150	198	264	0.020	0.87	1.09	15
	MMU-AP0364HP1-E	036	4.0	11.2	12.5	230-150	198	264	0.068	1.15	1.44	15
Compact 4-way Cassette (600 x 600) Type	MMU-AP0484HP1-E	048	5.0	14.0	16.0	230-150	198	264	0.072	1.15	1.44	15
	MMU-AP0564HP1-E	056	6	16.0	18.0	230-150	198	264	0.072	1.15	1.44	15
	MMU-AP0056MH1-E	005	0.6	1.7	1.9	230-150	198	264	0.060	0.32	0.40	15
	MMU-AP0074MH1-E	007	0.8	2.2	2.5	230-150	198	264	0.060	0.32	0.40	15
	MMU-AP0094MH1-E	009	1	2.8	3.2	230-150	198	264	0.060	0.35	0.44	15
	MMU-AP0124MH1-E	012	1.25	3.6	4.0	230-150	198	264	0.060	0.36	0.45	15
	MMU-AP0154MH1-E	015	1.7	4.5	5.0	230-150	198	264	0.060	0.48	0.60	15
	MMU-AP0184MH1-E	018	2	5.6	6.3	230-150	198	264	0.060	0.48	0.60	15
Compact 4-way Cassette (600 x 600) Type	MMU-AP0057MH-E	005	0.6	1.7	1.9	230-150	198	264	0.060	0.18	0.23	15
	MMU-AP0077MH-E	007	0.8	2.2	2.5	230-150	198	264	0.060	0.26	0.33	15
	MMU-AP0097MH-E	009	1	2.8	3.2	230-150	198	264	0.060	0.28	0.35	15
	MMU-AP0127MH-E	012	1.25	3.6	4.0	230-150	198	264	0.060	0.29	0.36	15
	MMU-AP0157MH-E	015	1.7	4.5	5.0	230-150	198	264	0.060	0.47	0.59	15
	MMU-AP0187MH-E	018	2	5.6	6.3	230-150	198	264	0.060	0.53	0.66	15
	MMU-AP0072WH1	007	0.8	2.2	2.5	230-150	198	264	0.020	0.32	0.40	15
	MMU-AP0092WH1	009	1	2.8	3.2	230-150	198	264	0.020	0.32	0.40	15
2-way Air Discharge Cassette Type	MMU-AP0122WH1	012	1.25	3.6	4.0	230-150	198	264	0.020	0.32	0.40	15
	MMU-AP0152WH1	015	1.7	4.5	5.0	230-150	198	264	0.020	0.32	0.40	15
	MMU-AP0182WH1	018	2	5.6	6.3	230-150	198	264	0.030	0.70	0.88	15
	MMU-AP0242WH1	024	2.5	7.1	8.0	230-150	198	264	0.040	0.81	1.01	15
	MMU-AP0272WH1	027	3	8.0	9.0	230-150	198	264	0.040	0.81	1.01	15
	MMU-AP0302WH1	030	3.2	9.0	10.0	230-150	198	264	0.050	0.81	1.01	15
	MMU-AP0362WH1	036	4.0	11.2	12.5	230-150	198	264	0.070	0.87	1.09	15
	MMU-AP0482WH1	048	5.0	14.0	16.0	230-150	198	264	0.070	0.87	1.09	15
1-way Air Discharge Cassette Type	MMU-AP0562WH1	056	6	16.0	18.0	230-150	198	264	0.070	0.87	1.09	15
	MMU-AP0074YH1-E	007	0.8	2.2	2.5	230-150	198	264	0.022	0.28	0.35	15
	MMU-AP0094YH1-E	009	1.0	2.8	3.2	230-150	198	264	0.022	0.28	0.35	15
	MMU-AP0124YH1-E	012	1.3	3.6	4.0	230-150	198	264	0.022	0.28	0.35	15
	MMU-AP0154SH1-E	015	1.7	4.5	5.0	230-150	198	264	0.030	0.40	0.49	15
	MMU-AP0184SH1-E	018	2.0	5.6	6.3	230-150	198	264	0.030	0.42	0.53	15
	MMU-AP0244SH1-E	024	2.5	7.1	8.0	230-150	198	264	0.030	0.71	0.88	15
	MMD-AP0076BHP1-E	007	0.8	2.2	2.5	230-150	198	264	0.120	0.30	0.37	15
Concealed Duct Type	MMD-AP0096BHP1-E	009	1.0	2.8	3.2	230-150	198	264	0.150	0.34	0.42	15
	MMD-AP0126BHP1-E	012	1.25	3.6	4.0	230-150	198	264	0.150	0.34	0.42	15
	MMD-AP0156BHP1-E	015	1.70	4.5	5.0	230-150	198	264	0.150	0.48	0.61	15
	MMD-AP0186BHP1-E	018	2.0	5.6	6.3	230-150	198	264	0.150	0.48	0.61	15
	MMD-AP0246BHP1-E	024	2.50	7.1	8.0	230-150	198	264	0.150	0.60	0.75	15
	MMD-AP0276BHP1-E	027	3.0	8.0	9.0	230-150	198	264	0.150	0.60	0.75	15
	MMD-AP0306BHP1-E	030	3.20	9.0	10.0	230-150	198	264	0.150	0.70	0.88	15
	MMD-AP0366BHP1-E	036	4.00	11.2	12.5	230-150	198	264	0.250	1.23	1.54	15
	MMD-AP0486BHP1-E	048	5.00	14.0	16.0	230-150	198	264	0.250	1.41	1.77	15
	MMD-AP0566BHP1-E	056	6.00	16.0	18.0	230-150	198	264	0.250	1.41	1.77	15
Slim Duct Type	MMD-AP0056SPH1-E	005	0.6	1.7	1.9	230-150	198	264	0.060	0.35	0.44	15
	MMD-AP0074SPH1-E	007	0.80	2.2	2.5	230-150	198	264	0.060	0.35	0.44	15
	MMD-AP0094SPH1-E	009	1.0	2.8	3.2	230-150	198	264	0.060	0.35	0.44	15
	MMD-AP0124SPH1-E	012	1.25	3.6	4.0	230-150	198	264	0.060	0.37	0.47	15
	MMD-AP0154SPH1-E	015	1.70	4.5	5.0	230-150	198	264	0.060	0.38	0.48	15
	MMD-AP0184SPH1-E	018	2.00	5.6	6.3	230-150	198	264	0.060	0.47	0.59	15
	MMD-AP0244SPH1-E	024	2.25	7.1	8.0	230-150	198	264	0.120	0.86	1.08	15
	MMD-AP0274SPH1-E	027	3.0	8.0	9.0	230-150	198	264	0.120	0.86	1.08	15
Concealed Duct High Static Pressure Type	MMD-AP0186HP1-E	018	2.0	5.6	6.3	230-150	198	264	0.250	1.02	1.28	15
	MMD-AP0246HP1-E	024	2.5	7.1	8.0	230-150	198	264	0.250	1.33	1.66	15
	MMD-AP0276HP1-E	027	3.0	8.0	9	230-150	198	264	0.250	1.33	1.66	15
	MMD-AP0366HP1-E	036	4.0	11.2	12.5	230-150	198	264	0.350	2.22	2.78	15
	MMD-AP0486HP1-E	048	5.0	14.0	16.0	230-150	198	264	0.350	2.40	2.99	15
	MMD-AP0566HP1-E	056	6.0	16.0	18.0	230-150	198	264	0.350	2.57	3.22	15
	MMD-AP0726HP-E	072	8.0	22.4	25.0	230-150	198	264	0.37x3	6.04	7.55	15
	MMD-AP0966HP-E	096	10.0	28.0	31.5	230-150	198	264	0.37x3	6.35	7.94	15
Under Ceiling Type	MMC-AP0158HP-E	015	1.7	4.5	5.0	230-150	198	264	0.094	0.41	0.52	15
	MMC-AP0188HP-E	018	2.0	5.6	6.3	230-150	198	264	0.094	0.42	0.53	15
	MMC-AP0248HP-E	024	2.5	7.1	8.0	230-150	198	264	0.094	0.75	0.93	15
	MMC-AP0278HP-E	027	3.0	8.0	9.0	230-150	198	264	0.094	0.75	0.93	15
	MMC-AP0368HP-E	036	4.0	11.2	12.5	230-150	198	264	0.139	0.89	1.11	15
	MMC-AP0488HP-E	048	5.0	14.0	16.0	230-150	198	264	0.139	0.89	1.11	15
	MMC-AP0568HP-E	056	6.0	16.0	18.0	230-150	198	264	0.139	1.14	1.43	15



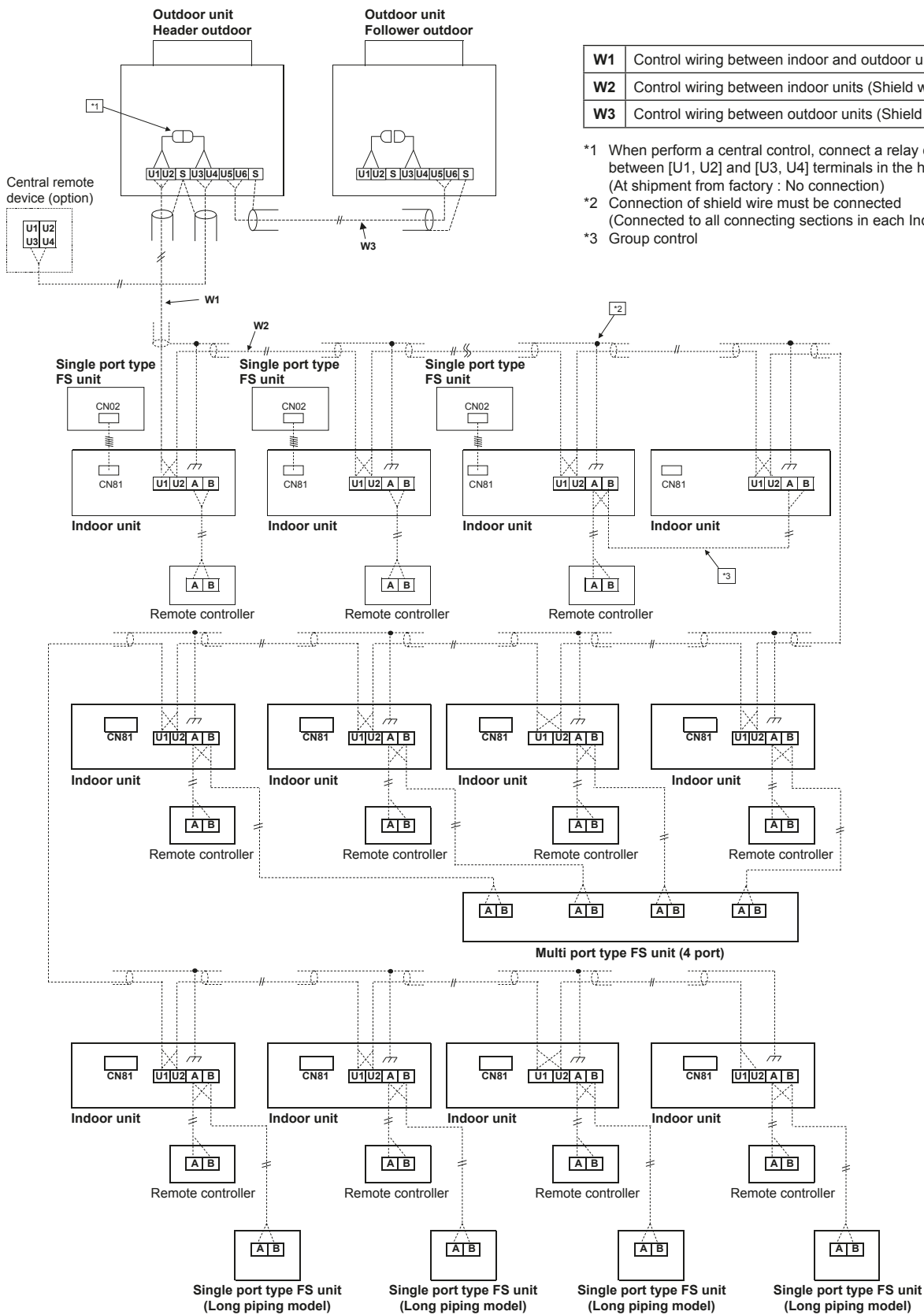
Electrical characteristics for 50 Hz outdoor units

Type	Model name	Capacity rank	Capacity Code	Cooling capacity(kW)	Heating capacity(kW)	Nominal Voltage (V-Ph-Hz)	Voltage Range		Fan Motor		Power Supply	
							Min	Max	kW	FLA	MCA	MOCp
High Wall Type 3 series	MMK-AP0073H1	007	0.8	2.2	2.5	230-1-50	198	264	0.030	0.20	0.22	15
	MMK-AP0093H1	009	1.0	2.8	3.2	230-1-50	198	264	0.030	0.22	0.24	15
	MMK-AP0123H1	012	1.25	3.6	4.0	230-1-50	198	264	0.030	0.22	0.24	15
	MMK-AP0153H1	015	1.7	4.5	5.0	230-1-50	198	264	0.030	0.37	0.40	15
	MMK-AP0183H1	018	2.0	5.6	6.3	230-1-50	198	264	0.030	0.37	0.40	15
	MMK-AP0243H1	024	2.5	7.1	8	230-1-50	198	264	0.030	0.43	0.47	15
High Wall Type 3 series (Without PMV)	MMK-AP0073HP1-E1	007	0.8	2.2	2.5	230-1-50	198	264	0.030	0.20	0.22	15
	MMK-AP0093HP1-E1	009	1.0	2.8	3.2	230-1-50	198	264	0.030	0.22	0.24	15
	MMK-AP0123HP1-E1	012	1.25	3.6	4.0	230-1-50	198	264	0.030	0.22	0.24	15
	MMK-AP0153HP1-E1	015	1.7	4.5	5.0	230-1-50	198	264	0.030	0.37	0.40	15
	MMK-AP0183HP1-E1	018	2.0	5.6	6.3	230-1-50	198	264	0.030	0.37	0.40	15
	MMK-AP0243HP1-E1	024	2.5	7.1	8	230-1-50	198	264	0.030	0.43	0.47	15
High Wall Type 4 series	MMK-AP0054MHP1-E	005	0.6	1.7	1.9	230-1-50	198	264	0.030	0.20	0.24	15
	MMK-AP0074MH1-E	007	0.8	2.2	2.5	230-1-50	198	264	0.030	0.20	0.24	15
	MMK-AP0094MH1-E	009	1	2.8	3.2	230-1-50	198	264	0.030	0.21	0.26	15
	MMK-AP0124MH1-E	012	1.25	3.6	4	230-1-50	198	264	0.030	0.22	0.27	15
High Wall Type 4 series (Without PMV)	MMK-AP0054MHP1-E1	005	0.6	1.7	1.9	230-1-50	198	264	0.030	0.20	0.24	15
	MMK-AP0074MHP1-E1	007	0.8	2.2	2.5	230-1-50	198	264	0.030	0.20	0.24	15
	MMK-AP0094MHP1-E1	009	1	2.8	3.2	230-1-50	198	264	0.030	0.21	0.26	15
	MMK-AP0124MHP1-E1	012	1.25	3.6	4	230-1-50	198	264	0.030	0.22	0.27	15
Floor Standing Concealed Type	MML-AP0074BH1-E	007	0.8	2.2	2.5	230-1-50	198	264	0.019	0.29	0.36	15
	MML-AP0094BH1-E	009	1	2.8	3.2	230-1-50	198	264	0.019	0.29	0.36	15
	MML-AP0124BH1-E	012	1.25	3.6	4	230-1-50	198	264	0.019	0.29	0.36	15
	MML-AP0154BH1-E	015	1.7	4.5	5	230-1-50	198	264	0.070	0.52	0.65	15
	MML-AP0184BH1-E	018	2	5.6	6.3	230-1-50	198	264	0.070	0.52	0.65	15
	MML-AP0244BH1-E	024	2.5	7.1	8	230-1-50	198	264	0.070	0.53	0.66	15
Floor Standing Cabinet Type	MML-AP0074H1-E	007	0.8	2.2	2.5	230-1-50	198	264	0.045	0.30	0.37	15
	MML-AP0094H1-E	009	1	2.8	3.2	230-1-50	198	264	0.045	0.30	0.37	15
	MML-AP0124H1-E	012	1.25	3.6	4	230-1-50	198	264	0.045	0.49	0.62	15
	MML-AP0154H1-E	015	1.7	4.5	5	230-1-50	198	264	0.045	0.49	0.62	15
	MML-AP0184H1-E	018	2	5.6	6.3	230-1-50	198	264	0.070	0.54	0.68	15
	MML-AP0244H1-E	024	2.5	7.1	8	230-1-50	198	264	0.070	0.54	0.68	15
Floor Standing Type	MMF-AP0156H1-E	015	1.7	4.5	5	230-1-50	198	264	0.062	0.44	0.56	15
	MMF-AP0186H1-E	018	2	5.6	6.3	230-1-50	198	264	0.062	0.44	0.56	15
	MMF-AP0246H1-E	024	2.5	7.1	8	230-1-50	198	264	0.062	0.69	0.86	15
	MMF-AP0276H1-E	027	3	8	9	230-1-50	198	264	0.062	0.69	0.86	15
	MMF-AP0366H1-E	036	4	11.2	12.5	230-1-50	198	264	0.109	1.04	1.29	15
	MMF-AP0486H1-E	048	5	14	16	230-1-50	198	264	0.109	1.27	1.58	15
	MMF-AP0566H1-E	056	6.0	16.0	18	230-1-50	198	264	0.109	1.27	1.58	15
Console Type	MML-AP0074NH1-E	007	0.8	2.2	2.5	230-1-50	198	264	0.041	0.21	0.26	15
	MML-AP0094NH1-E	009	1	2.8	3.2	230-1-50	198	264	0.041	0.21	0.26	15
	MML-AP0124NH1-E	012	1.3	4	4	230-1-50	198	264	0.041	0.25	0.31	15
	MML-AP0154NH1-E	015	1.7	5	5	230-1-50	198	264	0.041	0.32	0.40	15
	MML-AP0184NH1-E	018	2.0	5.6	6.3	230-1-50	198	264	0.041	0.46	0.58	15
Air to Air Heat exchanger with DX-coil Type	MMD-VN502HEX1E	009	1.0	4.1(1.30)*	5.53(2.33)*	230-1-50	198	264	0.248	1.50	1.70	15
	MMD-VN802HEX1E	015	1.7	6.56(2.06)*	8.61(3.61)*	230-1-50	198	264	0.254	2.60	3.00	15
	MMD-VN1002HEX1E	018	2.0	8.25(2.32)*	10.92(4.32)*	230-1-50	198	264	0.568	2.90	3.50	15
Air to Air Heat exchanger with DX-coil Humidifier Type	MMD-VNK502HEX1E	009	1	4.1(1.30)*	5.53(2.33)*	230-1-50	198	264	0.248	1.50	1.70	15
	MMD-VNK802HEX1E	015	1.7	6.56(2.06)*	8.61(3.61)*	230-1-50	198	264	0.254	2.60	2.90	15
	MMD-VNK1002HEX1E	018	2	8.25(2.32)*	10.92(4.32)*	230-1-50	198	264	0.568	2.90	3.40	15

* : The figures in () indicate the heat reclaimed from the heat recovery ventilator.

4-6. Design of control wiring

Summary of communication wiring



W1	Control wiring between indoor and outdoor units (Shield wire)
W2	Control wiring between indoor units (Shield wire)
W3	Control wiring between outdoor units (Shield wire)

- *1 When perform a central control, connect a relay connector between [U1, U2] and [U3, U4] terminals in the header unit. (At shipment from factory : No connection)
- *2 Connection of shield wire must be connected (Connected to all connecting sections in each Indoor unit)
- *3 Group control



Restriction of control wiring

Be sure to keep the rule of below tables about size and length of control wiring.

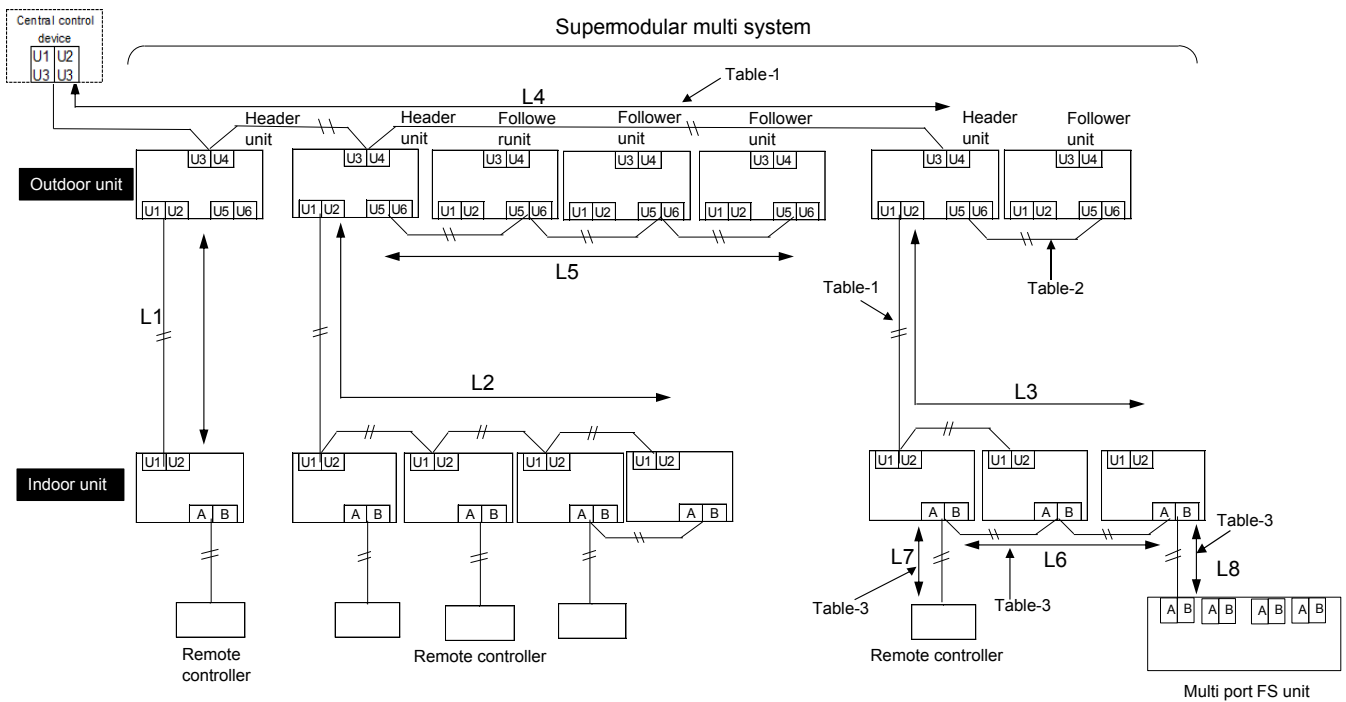


Table- 1 Control wiring between indoor and outdoor units (L1,L2,L3), Central control wiring (L4)

Wiring	2-core, non-polarity
Type	Shield wire
Size/Length	1.25 mm ² : Up to 1000 m / 2.0 mm ² : Up to 2000 m(*1)

Note (*1) Total length of control wiring length for all refrigerant circuits (L1+L2+L3+L4)

Table- 2 Controller wiring between outdoor units (L5)

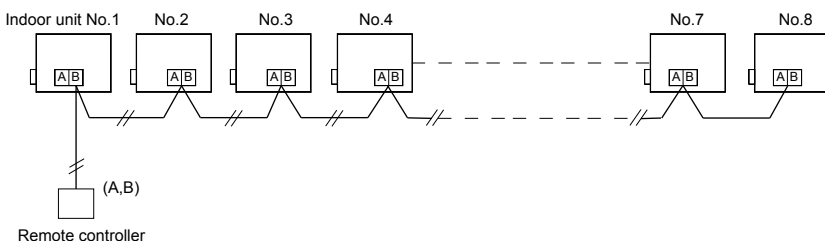
Wiring	2-core, non-polarity
Type	Shield wire
Size/Length	1.25 mm ² to 2.0 mm ² /Up to 100 m (L5)

Table- 3 Remote controller wiring (L6,L7) , Multi port FS unit wiring (L8)

Wire	2-core , non-polarity
Size	0.5mm ² to 2.0mm ²
Length	<ul style="list-style-type: none"> •Up to 500m(L6+L7) •Up to 400m in case of wireless remote controller in group control •Up to 200m total length of control wiring •between indoor units and Multi port FS unit(L6+L8) •Up to 300m(L6+L7+L8) •Up to 300m(L7)

Group Operation through Remote Controller

Group Operation of multiple indoor units (8 units) through a single remote controller switch





5-1. Specifications

Standard model (50Hz/380~415V)

Model name			Heat recovery		MMY-MAP0806FT8P-E	MMY-MAP1006FT8P-E	MMY-MAP1206FT8P-E	MMY-MAP1406FT8P-E
Outdoor unit type					Inverter unit			
Cooling capacity (*1)			Nominal.	kW	22.4	28.0	33.5	40.0
Heating capacity (*1)			Nominal.	kW	22.4	28.0	33.5	40.0
			Maximum.	kW	25.0	31.5	37.5	45.0
Capacity range					8	10	12	14
Power supply					3N~ 50Hz 400V(380-415V)	3N~ 50Hz 400V(380-415V)	3N~ 50Hz 400V(380-415V)	3N~ 50Hz 400V(380-415V)
Voltage range (*2)			Minimum	V	342	342	342	342
			Maximum	V	456	456	456	456
Electrical characteristic (*1)	Cooling	Running current	A		9.44	12.49	15.46	19.92
		Power input	kW		5.95	7.96	9.75	12.70
		EER	kW/kW		3.76	3.51	3.43	3.14
		Running current	A		8.57	11.06	13.80	16.47
	Heating	Power input	kW		5.40	7.05	8.70	10.50
		COP	kW/kW		4.14	3.97	3.85	3.80
		Starting current	A		Soft Start	Soft Start	Soft Start	Soft Start
		Starting current	A		Soft Start	Soft Start	Soft Start	Soft Start
Dimension	Height	mm		1830	1830	1830	1830	
	Width	mm		990	990	1210	1210	
	Depth	mm		780	780	780	780	
Weight	Heat recovery	kg		263	263	316	316	
Color					Silky shade (Munsell 1Y8.5/0.5)		Silky shade (Munsell 1Y8.5/0.5)	
Compressor	Type				Hermetic twin rotary compressor	Hermetic twin rotary compressor	Hermetic twin rotary compressor	Hermetic twin rotary compressor
	Motor output	kW		2.3x2	3.1x2	3.9x2	4.8x2	
Fan unit	Fan				Propeller fan	Propeller fan	Propeller fan	Propeller fan
	Motor output	W		1.0	1.0	1.0	1.0	
	Air volume	m3/h		9700	9700	12200	12200	
Max. external static pressure			Pa		60	50	50	40
Heat exchanger					Finned tube			
Refrigerant	Name				R410A	R410A	R410A	R410A
	Charge	Heat recovery	kg		11.0	11.0	11.0	11.0
High-pressure switch			MPa		OFF:2.9 ON:3.73	OFF:2.9 ON:3.73	OFF:2.9 ON:3.73	OFF:2.9 ON:3.73
Protective devices					(*3)			
Power supply wiring			MCA (*4)	A	21.5	26.1	31.0	35.8
			MOCP (*5)	A	25.0	32.0	40.0	50.0
Piping connections	Suction	Type			Brazing	Brazing	Brazing	Brazing
		Diameter	mm		22.2	22.2	28.6	28.6
	Discharge	Type			Brazing	Brazing	Brazing	Brazing
		Diameter	mm		19.1	19.1	19.1	22.2
	Liquid	Type			Flare	Flare	Flare	Flare
		Diameter	mm		12.7	12.7	12.7	15.9
	Balance	Type			Flare	Flare	Flare	Flare
		Diameter	mm		9.5	9.5	9.5	9.5
Max. number of connected indoor units (*8)					18	22	27	31
Sound pressure level	Cooling	dB(A)		59.0	59.0	60.0	62.0	
	Heating	dB(A)		61.0	61.0	62.0	64.0	
Sound power level	Cooling	dB(A)		80.0	80.0	80.0	81.0	
	Heating	dB(A)		82.0	82.0	82.0	83.0	
Operation temperature range	Cooling(*7)	CDB		-10.0 to 46.0	-10.0 to 46.0	-10.0 to 46.0	-10.0 to 46.0	
	Heating(*6)	CWB		-25.0 to 15.5	-25.0 to 15.5	-25.0 to 15.5	-25.0 to 15.5	

Note

(*1) Rated conditions

Cooling : Indoor 27 degC Dry Bulb /19 degC Wet Bulb , Outdoor 35 degC Dry Bulb.

Heating : Indoor 20 degC Dry Bulb , Outdoor 7 degC Dry Bulb / 6 degC Wet Bulb.

Based on equivalent piping length of 7.5m and piping height difference of 0m.

(*2) Voltage range : Units are suitable for use on electrical systems where voltage supplied to unit terminal is not below or above listed range limits.

(*3) Discharge temp. sensor / Suction temp. sensor / High-pressure sensor / Low-pressure sensor / Compressor case thermostat / PC board fuse

(*4) Select wire size base on the larger value of MCA.

MCA : Minimum Circuit Amps

(*5) MOCP : Maximum Overcurrent Protection(Amps)

(*6) Low ambient heating (-20degC or less) for extended periods of time is not allowed

(*7) Low ambient cooling (-5degC or less)

1. Not suitable for applications, which require precise room temperature control, due to increased risk of indoor ON/OFF control and potential low air off temperatures.

2. For areas that do demand a precise room temperature control, we would recommend the installation of a secondary system, which has been designed solely for the purpose of low ambient cooling.

(*8) Under centralized control maximum 54 unit.

Standard model (50Hz/380~415V)

Model name		Heat recovery		MMY-MAP1606FT8P-E	MMY-MAP1806FT8P-E	MMY-MAP2006FT8P-E	
Outdoor unit type				Inverter unit	Inverter unit	Inverter unit	
Cooling capacity (*1)	Nominal.	kW		45.0	50.4	56.0	
	Maximum.	kW		45.0	50.4	56.0	
Heating capacity (*1)	Nominal.	kW		50.0	56.5	58.0	
	Maximum.	kW		50.0	56.5	58.0	
Capacity range		HP		16	18	20	
Power supply				3N~ 50Hz 400V(380-415V)	3N~ 50Hz 400V(380-415V)	3N~ 50Hz 400V(380-415V)	
Voltage range (*2)	Minimum	V		342	342	342	
	Maximum	V		456	456	456	
Electrical characteristic (*1)	Cooling	Running current	A	21.81	25.10	29.18	
		Power input	kW	13.90	16.00	18.60	
		EER	kW/kW	3.23	3.15	3.01	
	Heating	Running current	A	19.14	21.49	24.68	
		Power input	kW	12.20	13.70	15.90	
		COP	kW/kW	3.68	3.67	3.52	
	Starting current	A		Soft Start	Soft Start	Soft Start	
Dimension	Height	mm		1830	1830	1830	
	Width	mm		1600	1600	1600	
	Depth	mm		780	780	780	
Weight	Heat recovery	kg		377	377	377	
Color				Silky shade (Munsell 1Y8.5/0.5)	Silky shade (Munsell 1Y8.5/0.5)	Silky shade (Munsell 1Y8.5/0.5)	
Compressor	Type			Hermetic twin rotary compressor	Hermetic twin rotary compressor	Hermetic twin rotary compressor	
	Motor output	kW		5.8x2	6.5x2	7.6x2	
Fan unit	Fan			Propeller fan	Propeller fan	Propeller fan	
	Motor output	kW		2.0	2.0	2.0	
	Air volume	m3/h		17300	17300	17900	
Max. external static pressure		Pa		40	40	40	
Heat exchanger				Finned tube	Finned tube	Finned tube	
Refrigerant	Name			R410A	R410A	R410A	
	Charge	Heat recovery	kg	11.0	11.0	11.0	
High-pressure switch		MPa		OFF:2.9 ON:3.73	OFF:2.9 ON:3.73	OFF:2.9 ON:3.73	
Protective devices				(*3)	(*3)	(*3)	
Power supply wiring	MCA (*4)	A		40.6	44.9	49.3	
	MOCP (*5)	A		50.0	50.0	63.0	
Piping connections	Suction	Type			Brazing	Brazing	Brazing
		Diameter	mm		28.6	28.6	28.6
	Discharge	Type			Brazing	Brazing	Brazing
		Diameter	mm		22.2	22.2	22.2
	Liquid	Type			Flare	Flare	Flare
		Diameter	mm		19.1	19.1	19.1
	Balance	Type			Flare	Flare	Flare
		Diameter	mm		9.5	9.5	9.5
Max. number of connected indoor units (*8)				36	40	41	
Sound pressure level	Cooling	dB(A)		61.0	61.0	61.0	
	Heating	dB(A)		62.0	62.0	62.0	
Sound power level	Cooling	dB(A)		83.0	83.0	83.0	
	Heating	dB(A)		84.0	84.0	84.0	
Operation temperature range	Cooling(*7)	CDB		-10.0 to 46.0	-10.0 to 46.0	-10.0 to 46.0	
	Heating(*6)	CWB		-25.0 to 15.5	-25.0 to 15.5	-25.0 to 15.5	

Note

(*1) Rated conditions

Cooling : Indoor 27 degC Dry Bulb /19 degC Wet Bulb , Outdoor 35 degC Dry Bulb.

Heating : Indoor 20 degC Dry Bulb, Outdoor 7 degC Dry Bulb / 6 degC Wet Bulb.

Based on equivalent piping length of 7.5m and piping height difference of 0m.

(*2) Voltage range : Units are suitable for use on electrical systems where voltage supplied to unit terminal is not below or above listed range limits.

(*3) Discharge temp. sensor / Suction temp. sensor / High-pressure sensor / Low-pressure sensor / Compressor case thermostat / PC board fuse

(*4) Select wire size base on the larger value of MCA.

MCA : Minimum Circuit Amps

(*5) MOCP : Maximum Overcurrent Protection(Amps)

(*6) Low ambient heating (-20degC or less) for extended periods of time is not allowed

(*7) Low ambient cooling (-5degC or less)

1. Not suitable for applications, which require precise room temperature control, due to increased risk of indoor ON/OFF control and potential low air off temperatures.

2. For areas that do demand a precise room temperature control, we would recommend the installation of a secondary system, which has been designed solely for the purpose of low ambient cooling.

(*8) Under centralized control maximum 54 unit.

Standard model (50Hz/380~415V)

Model	Name	Heat recovery		MMY-AP2216FT8P-E	MMY-AP2416FT8P-E	MMY-AP2616FT8P-E	MMY-AP2816FT8P-E
	Combination	Heat recovery		MMY-MAP1206FT8P-E	MMY-MAP1406FT8P-E	MMY-MAP1406FT8P-E	MMY-MAP1406FT8P-E
				MMY-MAP1006FT8P-E	MMY-MAP1006FT8P-E	MMY-MAP1206FT8P-E	MMY-MAP1406FT8P-E
Outdoor unit type				Inverter unit	Inverter unit	Inverter unit	Inverter unit
Cooling capacity (*1)		Nominal.	kW	61.5	68.0	73.5	80.0
Heating capacity (*1)		Nominal.	kW	61.5	68.0	73.5	80.0
		Maximum.	kW	69.0	76.5	82.5	90.0
Capacity range			HP	22	24	26	28
Power supply				3N~ 50Hz 400V(380-415V)	3N~ 50Hz 400V(380-415V)	3N~ 50Hz 400V(380-415V)	3N~ 50Hz 400V(380-415V)
Voltage range (*2)		Minimum	V	342	342	342	342
		Maximum	V	456	456	456	456
Electrical characteristic (*1)	Cooling	Running current	A	27.94	32.41	35.41	39.85
		Power input	kW	17.71	20.66	22.45	25.40
		EER	kW/kW	3.47	3.29	3.27	3.15
		Running current	A	24.85	27.53	30.29	32.95
	Heating	Power input	kW	15.75	17.55	19.20	21.00
		COP	kW/kW	3.90	3.87	3.83	3.81
	Starting current	A		Soft Start	Soft Start	Soft Start	Soft Start
Weight	Heat recovery		kg	316 + 263	316 + 263	316 + 316	316 + 316
Color				Silky shade (Munsell 1Y8.5/0.5)	Silky shade (Munsell 1Y8.5/0.5)	Silky shade (Munsell 1Y8.5/0.5)	Silky shade (Munsell 1Y8.5/0.5)
Compressor	Type			Hermetic twin rotary compressor	Hermetic twin rotary compressor	Hermetic twin rotary compressor	Hermetic twin rotary compressor
	Motor output		kW	3.9x2 + 3.1x2	4.8x2 + 3.1x2	4.8x2 + 3.9x2	4.8x2 + 4.8x2
Fan unit	Fan			Propeller fan	Propeller fan	Propeller fan	Propeller fan
	Motor output		kW	1.0 + 1.0	1.0 + 1.0	1.0 + 1.0	1.0 + 1.0
	Air volume		m ³ /h	12200 + 9700	12200 + 9700	12200 + 12200	12200 + 12200
Max. external static pressure			Pa	50	40	40	40
Heat exchanger				Finned tube	Finned tube	Finned tube	Finned tube
Refrigerant	Name			R410A	R410A	R410A	R410A
	Charge	Heat recovery	kg	11.0 + 11.0	11.0 + 11.0	11.0 + 11.0	11.0 + 11.0
High-pressure switch			MPa	OFF:2.9 ON:3.73	OFF:2.9 ON:3.73	OFF:2.9 ON:3.73	OFF:2.9 ON:3.73
Protective devices				(*3)	(*3)	(*3)	(*3)
Power supply wiring		MCA (*4)	A	57.1	62.0	66.8	71.6
		MOCP (*5)	A	63.0	80.0	80.0	80.0
Piping connections	Suction	Type		Brazing	Brazing	Brazing	Brazing
		Diameter	mm	34.9	34.9	34.9	34.9
	Discharge	Type		Brazing	Brazing	Brazing	Brazing
		Diameter	mm	28.6	28.6	28.6	28.6
	Liquid	Type		Flare	Flare	Flare	Flare
		Diameter	mm	19.1	19.1	22.2	22.2
	Balance	Type		Flare	Flare	Flare	Flare
		Diameter	mm	9.5	9.5	9.5	9.5
Max. number of connected indoor units (*8)				49	54	58	63
Sound pressure level		Cooling	dB(A)	63.0	64.0	64.5	65.5
		Heating	dB(A)	65.0	66.0	66.5	67.5
Sound power level		Cooling	dB(A)	83.5	84.0	84.0	84.5
		Heating	dB(A)	85.5	86.0	86.0	86.5
Operation temperature range		Cooling(*7)	CDB	-10.0 to 46.0	-10.0 to 46.0	-10.0 to 46.0	-10.0 to 46.0
		Heating(*6)	CWB	-25.0 to 15.5	-25.0 to 15.5	-25.0 to 15.5	-25.0 to 15.5

Note

(*1) Rated conditions

Cooling : Indoor 27 degC Dry Bulb / 19 degC Wet Bulb , Outdoor 35 degC Dry Bulb.

Heating : Indoor 20 degC Dry Bulb , Outdoor 7 degC Dry Bulb / 6 degC Wet Bulb.

Based on equivalent piping length of 7.5m and piping height difference of 0m.

(*2) Voltage range : Units are suitable for use on electrical systems where voltage supplied to unit terminal is not below or above listed range limits.

(*3) Discharge temp. sensor / Suction temp. sensor / High-pressure sensor / Low-pressure sensor / Compressor case thermostat / PC board fuse

(*4) Select wire size base on the larger value of MCA.

MCA : Minimum Circuit Amps

(*5) MOCP : Maximum Overcurrent Protection(Amps)

(*6) Low ambient heating (-20degC or less) for extended periods of time is not allowed

(*7) Low ambient cooling (-5degC or less)

1. Not suitable for applications, which require precise room temperature control, due to increased risk of indoor ON/OFF control and potential low air off temperatures.

2. For areas that do demand a precise room temperature control, we would recommend the installation of a secondary system, which has been designed solely for the purpose of low ambient cooling.

(*8) Under centralized control maximum 54 unit.

Standard model (50Hz/380~415V)

Model	Name		Heat recovery		MMY-AP3016FT8P-E	MMY-AP3216FT8P-E	MMY-AP3416FT8P-E
	Combination	Heat recovery		MMY-MAP1606FT8P-E	MMY-MAP1806FT8P-E	MMY-MAP1806FT8P-E	
				MMY-MAP1406FT8P-E	MMY-MAP1406FT8P-E	MMY-MAP1606FT8P-E	
Outdoor unit type					Inverter unit	Inverter unit	Inverter unit
Cooling capacity (*1)		Nominal.	kW	85.0	90.4	95.4	
Heating capacity (*1)		Nominal.	kW	85.0	90.4	95.4	
		Maximum.	kW	95.0	101.5	106.5	
Capacity range				30	32	34	
Power supply				3N~ 50Hz 400V(380-415V)	3N~ 50Hz 400V(380-415V)	3N~ 50Hz 400V(380-415V)	
Voltage range (*2)		Minimum	V	342	342	342	
		Maximum	V	456	456	456	
Electrical characteristic (*1)	Cooling	Running current	A	41.73	45.03	46.91	
		Power input	kW	26.60	28.70	29.90	
		EER	kW/kW	3.20	3.15	3.19	
	Heating	Running current	A	35.61	38.28	40.63	
		Power input	kW	22.70	24.40	25.90	
		COP	kW/kW	3.74	3.70	3.68	
	Starting current		A		Soft Start	Soft Start	Soft Start
Weight	Heat recovery		kg	377 + 316	377 + 316	377 + 377	
Color				Silky shade (Munsell 1Y8.5/0.5)	Silky shade (Munsell 1Y8.5/0.5)	Silky shade (Munsell 1Y8.5/0.5)	
Compressor	Type				Hermetic twin rotary compressor	Hermetic twin rotary compressor	Hermetic twin rotary compressor
	Motor output		kW		5.8x2 + 4.8x2	6.5x2 + 4.8x2	6.5x2 + 5.8x2
Fan unit	Fan				Propeller fan	Propeller fan	Propeller fan
	Motor output		kW		2.0 + 1.0	2.0 + 1.0	2.0 + 2.0
	Air volume		m3/h		17300 + 12200	17300 + 12200	17300 + 17300
Max. external static pressure		Pa		40	40	40	
Heat exchanger				Finned tube	Finned tube	Finned tube	
Refrigerant	Name				R410A	R410A	R410A
	Charge	Heat recovery	kg	11.0 + 11.0	11.0 + 11.0	11.0 + 11.0	
High-pressure switch		MPa		OFF:2.9 ON:3.73	OFF:2.9 ON:3.73	OFF:2.9 ON:3.73	
Protective devices				(*3)	(*3)	(*3)	
Power supply wiring		MCA (*4)	A	76.5	81.3	85.6	
		MOCP (*5)	A	100.0	100.0	100.0	
Piping connections	Suction	Type			Brazing	Brazing	Brazing
		Diameter	mm	34.9	34.9	34.9	
	Discharge	Type			Brazing	Brazing	Brazing
		Diameter	mm	28.6	28.6	28.6	
	Liquid	Type			Flare	Flare	Flare
		Diameter	mm	22.2	22.2	22.2	
	Balance	Type			Flare	Flare	Flare
		Diameter	mm	9.5	9.5	9.5	
Max. number of connected indoor units (*8)				64	64	64	
Sound pressure level		Cooling	dB(A)	65.0	65.0	64.5	
		Heating	dB(A)	66.5	66.5	65.5	
Sound power level		Cooling	dB(A)	85.5	85.5	86.5	
		Heating	dB(A)	87.0	87.0	87.5	
Operation temperature range		Cooling(*7)	CDB	-10.0 to 46.0	-10.0 to 46.0	-10.0 to 46.0	
		Heating(*6)	CWB	-25.0 to 15.5	-25.0 to 15.5	-25.0 to 15.5	

Note

(*1) Rated conditions

Cooling : Indoor 27 degC Dry Bulb / 19 degC Wet Bulb , Outdoor 35 degC Dry Bulb.

Heating : Indoor 20 degC Dry Bulb , Outdoor 7 degC Dry Bulb / 6 degC Wet Bulb.

Based on equivalent piping length of 7.5m and piping height difference of 0m.

(*2) Voltage range : Units are suitable for use on electrical systems where voltage supplied to unit terminal is not below or above listed range limits.

(*3) Discharge temp. sensor / Suction temp. sensor / High-pressure sensor / Low-pressure sensor / Compressor case thermostat / PC board fuse

(*4) Select wire size base on the larger value of MCA.

MCA : Minimum Circuit Amps

(*5) MOCP : Maximum Overcurrent Protection(Amps)

(*6) Low ambient heating (-20degC or less) for extended periods of time is not allowed

(*7) Low ambient cooling (-5degC or less)

1. Not suitable for applications, which require precise room temperature control, due to increased risk of indoor ON/OFF control and potential low air off temperatures.

2. For areas that do demand a precise room temperature control, we would recommend the installation of a secondary system, which has been designed solely for the purpose of low ambient cooling.

(*8) Under centralized control maximum 54 unit.

Standard model (50Hz/380~415V)

Model	Name	Heat recovery		MMY-AP3616FT8P-E	MMY-AP3816FT8P-E	MMY-AP4016FT8P-E	
	Combination	Heat recovery		MMY-MAP1806FT8P-E	MMY-MAP2006FT8P-E	MMY-MAP2006FT8P-E	
Outdoor unit type				Inverter unit	Inverter unit	Inverter unit	
Cooling capacity (*1)	Nominal.	kW		100.8	106.4	112.0	
Heating capacity (*1)	Nominal.	kW		100.8	106.4	112.0	
	Maximum.	kW		113.0	114.5	116.0	
Capacity range		HP		36	38	40	
Power supply				3N~ 50Hz 400V(380-415V)	3N~ 50Hz 400V(380-415V)	3N~ 50Hz 400V(380-415V)	
Voltage range (*2)	Minimum	V		342	342	342	
	Maximum	V		456	456	456	
Electrical characteristic (*1)	Cooling	Running current	A	50.20	54.28	58.36	
		Power input	kW	32.00	34.60	37.20	
		EER	kW/kW	3.15	3.08	3.01	
		Running current	A	42.99	46.19	49.35	
	Heating	Power input	kW	27.40	29.60	31.80	
		COP	kW/kW	3.68	3.59	3.52	
	Starting current	A		Soft Start	Soft Start	Soft Start	
Weight	Heat recovery	kg		377 + 377	377 + 377	377 + 377	
Color				Silky shade (Munsell 1Y8.5/0.5)	Silky shade (Munsell 1Y8.5/0.5)	Silky shade (Munsell 1Y8.5/0.5)	
Compressor	Type				Hermetic twin rotary compressor	Hermetic twin rotary compressor	Hermetic twin rotary compressor
	Motor output	kW		6.5x2 +6.5x2	7.6x2 +6.5x2	7.6x2 +7.6x2	
Fan unit	Fan				Propeller fan	Propeller fan	Propeller fan
	Motor output	kW		2.0 + 2.0	2.0 + 2.0	2.0 + 2.0	
	Air volume	m3/h		17300 + 17300	17900 + 17300	17900 + 17900	
Max. external static pressure		Pa		40	40	40	
Heat exchanger				Finned tube	Finned tube	Finned tube	
Refrigerant	Name				R410A	R410A	R410A
	Charge	Heat recovery	kg	11.0 + 11.0	11.0 + 11.0	11.0 + 11.0	
High-pressure switch		MPa		OFF:2.9 ON:3.73	OFF:2.9 ON:3.73	OFF:2.9 ON:3.73	
Protective devices				(*3)	(*3)	(*3)	
Power supply wiring	MCA (*4)	A		89.8	94.2	98.6	
	MOCP (*5)	A		100.0	125.0	125.0	
Piping connections	Suction	Type		Brazing	Brazing	Brazing	
		Diameter	mm	41.3	41.3	41.3	
	Discharge	Type		Brazing	Brazing	Brazing	
		Diameter	mm	34.9	34.9	34.9	
	Liquid	Type		Flare	Flare	Flare	
		Diameter	mm	22.2	22.2	22.2	
	Balance	Type		Flare	Flare	Flare	
		Diameter	mm	9.5	9.5	9.5	
Max. number of connected indoor units (*8)				64	64	64	
Sound pressure level	Cooling	dB(A)		64.5	64.5	64.5	
	Heating	dB(A)		65.5	65.5	65.5	
Sound power level	Cooling	dB(A)		86.5	86.5	86.5	
	Heating	dB(A)		87.5	87.5	87.5	
Operation temperature range	Cooling(*7)	CDB		-10.0 to 46.0	-10.0 to 46.0	-10.0 to 46.0	
	Heating(*6)	CWB		-25.0 to 15.5	-25.0 to 15.5	-25.0 to 15.5	

Note

(*1) Rated conditions

Cooling : Indoor 27 degC Dry Bulb /19 degC Wet Bulb , Outdoor 35 degC Dry Bulb.

Heating : Indoor 20 degC Dry Bulb, Outdoor 7 degC Dry Bulb / 6 degC Wet Bulb.

Based on equivalent piping length of 7.5m and piping height difference of 0m.

(*2) Voltage range : Units are suitable for use on electrical systems where voltage supplied to unit terminal is not below or above listed range limits.

(*3) Discharge temp. sensor / Suction temp. sensor / High-pressure sensor / Low-pressure sensor / Compressor case thermostat / PC board fuse

(*4) Select wire size base on the larger value of MCA.

MCA : Minimum Circuit Amps

(*5) MOCP : Maximum Overcurrent Protection(Amps)

(*6) Low ambient heating (-20degC or less) for extended periods of time is not allowed

(*7) Low ambient cooling (-5degC or less)

1. Not suitable for applications, which require precise room temperature control, due to increased risk of indoor ON/OFF control and potential low air off temperatures.

2. For areas that do demand a precise room temperature control, we would recommend the installation of a secondary system, which has been designed solely for the purpose of low ambient cooling.

(*8) Under centralized control maximum 54 unit.



Standard model (50Hz/380~415V)

Model	Name	Heat recovery		MMY-AP4216FT8P-E	MMY-AP4416FT8P-E	MMY-AP4616FT8P-E	MMY-AP4816FT8P-E	
	Combination	Heat recovery		MMY-MAP1406FT8P-E	MMY-MAP1606FT8P-E	MMY-MAP1806FT8P-E	MMY-MAP1806FT8P-E	
				MMY-MAP1406FT8P-E	MMY-MAP1406FT8P-E	MMY-MAP1406FT8P-E	MMY-MAP1606FT8P-E	
				MMY-MAP1406FT8P-E	MMY-MAP1406FT8P-E	MMY-MAP1406FT8P-E	MMY-MAP1406FT8P-E	
Outdoor unit type				Inverter unit	Inverter unit	Inverter unit	Inverter unit	
Cooling capacity (*1)	Nominal.	kW		120.0	125.0	130.4	135.4	
Heating capacity (*1)	Nominal.	kW		120.0	125.0	130.4	135.4	
	Maximum.	kW		135.0	140.0	146.5	151.5	
Capacity range			HP	42	44	46	48	
Power supply				3N~ 50Hz 400V(380-415V)	3N~ 50Hz 400V(380-415V)	3N~ 50Hz 400V(380-415V)	3N~ 50Hz 400V(380-415V)	
Voltage range (*2)	Minimum	V		342	342	342	342	
	Maximum	V		456	456	456	456	
Electrical characteristic (*1)	Cooling	Running current	A	59.8	61.7	65.0	65.4	
		Power input	kW	38.1	39.3	41.4	41.7	
		EER	kW/kW	3.15	3.18	3.15	3.25	
	Heating	Running current	A	49.4	52.1	54.4	57.4	
		Power input	kW	31.5	33.2	34.7	36.6	
		COP	kW/kW	3.81	3.77	3.76	3.70	
	Starting current			A	Soft Start	Soft Start	Soft Start	Soft Start
Weight	Heat recovery			kg	316 + 316 + 316	377 + 316 + 316	377 + 316 + 316	377 + 316 + 316
color				Silky shade (Munsell 1Y8.5/0.5)	Silky shade (Munsell 1Y8.5/0.5)	Silky shade (Munsell 1Y8.5/0.5)	Silky shade (Munsell 1Y8.5/0.5)	
Compressor	Type			Hermetic twin rotary compressor	Hermetic twin rotary compressor	Hermetic twin rotary compressor	Hermetic twin rotary compressor	
	Motor output			kW	4.8x2 + 4.8x2 + 4.8x2	5.8x2 + 4.8x2 + 4.8x2	6.5x2 + 4.8x2 + 4.8x2	6.5x2 + 5.8x2 + 4.8x2
Fan unit	Fan			Propeller fan	Propeller fan	Propeller fan	Propeller fan	
	Motor output			kW	1.0 + 1.0 + 1.0	2.0 + 1.0 + 1.0	2.0 + 1.0 + 1.0	2.0 + 2.0 + 1.0
	Air volume			m3/h	12200 + 12200 + 12200	17300 + 12200 + 12200	17300 + 12200 + 12200	17300 + 17300 + 12200
Max. external static pressure			Pa	40	40	40	40	
Heat exchanger				Finned tube	Finned tube	Finned tube	Finned tube	
Refrigerant	Name			R410A	R410A	R410A	R410A	
	Charge	Heat recovery	kg	11.0 + 11.0 + 11.0	11.0 + 11.0 + 11.0	11.0 + 11.0 + 11.0	11.0 + 11.0 + 11.0	
High-pressure switch			MPa	OFF:2.9 ON:3.73	OFF:2.9 ON:3.73	OFF:2.9 ON:3.73	OFF:2.9 ON:3.73	
Protective devices				(*3)	(*3)	(*3)	(*3)	
Power supply wiring	MCA (*4)			A	107.4	112.3	116.5	122.0
	MOCP (*5)			A	125.0	125.0	160.0	160.0
Piping connections	Suction	Type			Brazing	Brazing	Brazing	Brazing
		Diameter			mm	41.3	41.3	41.3
	Discharge	Type			Brazing	Brazing	Brazing	Brazing
		Diameter			mm	34.9	34.9	34.9
	Liquid	Type			Flare	Flare	Flare	Flare
		Diameter			mm	22.2	22.2	22.2
	Balance	Type			Flare	Flare	Flare	Flare
Diameter				mm	9.5	9.5	9.5	9.5
Max. number of connected indoor units (*8)				64	64	64	64	
Sound pressure level	Cooling	dB(A)		67.0	66.5	66.5	66.5	
	Heating	dB(A)		69.0	68.5	68.5	68.0	
Sound power level	Cooling(*7)	dB(A)		86.0	87.0	87.0	87.5	
	Heating	dB(A)		88.0	88.5	88.5	88.5	
Operation temperature range	Cooling(*7)	CDB		-10.0 to 46.0	-10.0 to 46.0	-10.0 to 46.0	-10.0 to 46.0	
	Heating(*6)	CWB		-25.0 to 15.5	-25.0 to 15.5	-25.0 to 15.5	-25.0 to 15.5	

Note

(*1) Rated conditions

Cooling : Indoor 27 degC Dry Bulb /19 degC Wet Bulb , Outdoor 35 degC Dry Bulb.

Heating : Indoor 20 degC Dry Bulb, Outdoor 7 degC Dry Bulb / 6 degC Wet Bulb.

Based on equivalent piping length of 7.5m and piping height difference of 0m.

(*2) Voltage range : Units are suitable for use on electrical systems where voltage supplied to unit terminal is not below or above listed range limits.

(*3) Discharge temp. sensor / Suction temp. sensor / High-pressure sensor / Low-pressure sensor / Compressor case thermostat / PC board fuse

(*4) Select wire size base on the larger value of MCA.

MCA : Minimum Circuit Amps

(*5) MOCP : Maximum Overcurrent Protection(Amps)

(*6) Low ambient heating (-20degC or less) for extended periods of time is not allowed

(*7) Low ambient cooling (-5degC or less)

1. Not suitable for applications, which require precise room temperature control, due to increased risk of indoor ON/OFF control and potential low air off temperatures.

2. For areas that do demand a precise room temperature control, we would recommend the installation of a secondary system, which has been designed solely for the purpose of low ambient cooling.

(*8) Under centralized control maximum 54 unit.

Standard model (50Hz/380~415V)

Model	Name	Heat recovery		MMY-AP5016FT8P-E	MMY-AP5216FT8P-E	MMY-AP5416FT8P-E
	Combination	Heat recovery		MMY-MAP1806FT8P-E	MMY-MAP1806FT8P-E	MMY-MAP1806FT8P-E
				MMY-MAP1806FT8P-E	MMY-MAP1806FT8P-E	MMY-MAP1806FT8P-E
				MMY-MAP1406FT8P-E	MMY-MAP1606FT8P-E	MMY-MAP1806FT8P-E
Outdoor unit type				Inverter unit	Inverter unit	Inverter unit
Cooling capacity (*1)		Nominal.	kW	140.8	145.8	151.2
Heating capacity (*1)		Nominal.	kW	140.8	145.8	151.2
		Maximum.	kW	158.0	163.0	169.5
Capacity range			HP	50	52	54
Power supply				3N~ 50Hz 400V(380-415V)	3N~ 50Hz 400V(380-415V)	3N~ 50Hz 400V(380-415V)
Voltage range (*2)		Minimum	V	342	342	342
		Maximum	V	456	456	456
Electrical characteristic (*1)	Cooling	Running current	A	70.1	72.0	75.3
		Power input	kW	44.7	45.9	48.0
		EER	kW/kW	3.15	3.18	3.15
		Running current	A	59.8	62.1	64.5
	Heating	Power input	kW	38.1	39.6	41.1
		COP	kW/kW	3.70	3.68	3.68
		Starting current	A	Soft Start	Soft Start	Soft Start
	Weight	Heat recovery	MPa	377 + 377 + 316	377 + 377 + 377	377 + 377 + 377
color				Silky shade (Munsell 1Y8.5/0.5)	Silky shade (Munsell 1Y8.5/0.5)	Silky shade (Munsell 1Y8.5/0.5)
Compressor	Type			Hermetic twin rotary compressor	Hermetic twin rotary compressor	Hermetic twin rotary compressor
	Motor output		kW	6.5x2 + 6.5x2 + 4.8x2	6.5x2 + 6.5x2 + 5.8x2	6.5x2 + 6.5x2 + 6.5x2
Fan unit	Fan			Propeller fan	Propeller fan	Propeller fan
	Motor output		kW	2.0 + 2.0 + 1.0	2.0 + 2.0 + 2.0	2.0 + 2.0 + 2.0
	Air volume		m3/h	17300 + 17300 + 12200	17300 + 17300 + 17300	17300 + 17300 + 17300
Max. external static pressure			Pa	40	40	40
Heat exchanger				Finned tube	Finned tube	Finned tube
Refrigerant	Name			R410A	R410A	R410A
	Charge	Heat recovery	kg	11.0 + 11.0 + 11.0	11.0 + 11.0 + 11.0	11.0 + 11.0 + 11.0
High-pressure switch			Pa	OFF:2.9 ON:3.73	OFF:2.9 ON:3.73	OFF:2.9 ON:3.73
Protective devices				(*3)	(*3)	(*3)
Power supply wiring		MCA (*4)	A	126.2	130.5	134.7
		MOCP (*5)	A	160.0	160.0	160.0
Piping connections	Suction	Type		Brazing	Brazing	Brazing
		Diameter	mm	41.3	41.3	41.3
	Discharge	Type		Brazing	Brazing	Brazing
		Diameter	mm	34.9	34.9	34.9
	Liquid	Type		Flare	Flare	Flare
		Diameter	mm	22.2	22.2	22.2
	Balance	Type		Flare	Flare	Flare
		Diameter	mm	9.5	9.5	9.5
Max. number of connected indoor units (*8)				64	64	64
Sound pressure level		Cooling	dB(A)	66.5	66.0	66.0
		Heating	dB(A)	68.0	67.0	67.0
Sound power level		Cooling	dB(A)	87.5	88.0	88.0
		Heating	dB(A)	88.5	89.0	89.0
Operation temperature range		Cooling(*7)	CDB	-10.0 to 46.0	-10.0 to 46.0	-10.0 to 46.0
		Heating(*6)	CWB	-25.0 to 15.5	-25.0 to 15.5	-25.0 to 15.5

Note

(*1) Rated conditions

Cooling : Indoor 27 degC Dry Bulb /19 degC Wet Bulb , Outdoor 35 degC Dry Bulb.

Heating : Indoor 20 degC Dry Bulb , Outdoor 7 degC Dry Bulb / 6 degC WetBulb.

Based on equivalent piping length of 7.5m and piping height difference of 0m.

(*2) Voltage range : Units are suitable for use on electrical systems where voltage supplied to unit terminal is not below or above listed range limits.

(*3) Discharge temp. sensor / Suction temp. sensor / High-pressure sensor / Low-pressure sensor / Compressor case thermostat / PC board fuse

(*4) Select wire size base on the larger value of MCA.

MCA : Minimum Circuit Amps

(*5) MOCP : Maximum Overcurrent Protection(Amps)

(*6) Low ambient heating (-20degC or less) for extended periods of time is not allowed

(*7) Low ambient cooling (-5degC or less)

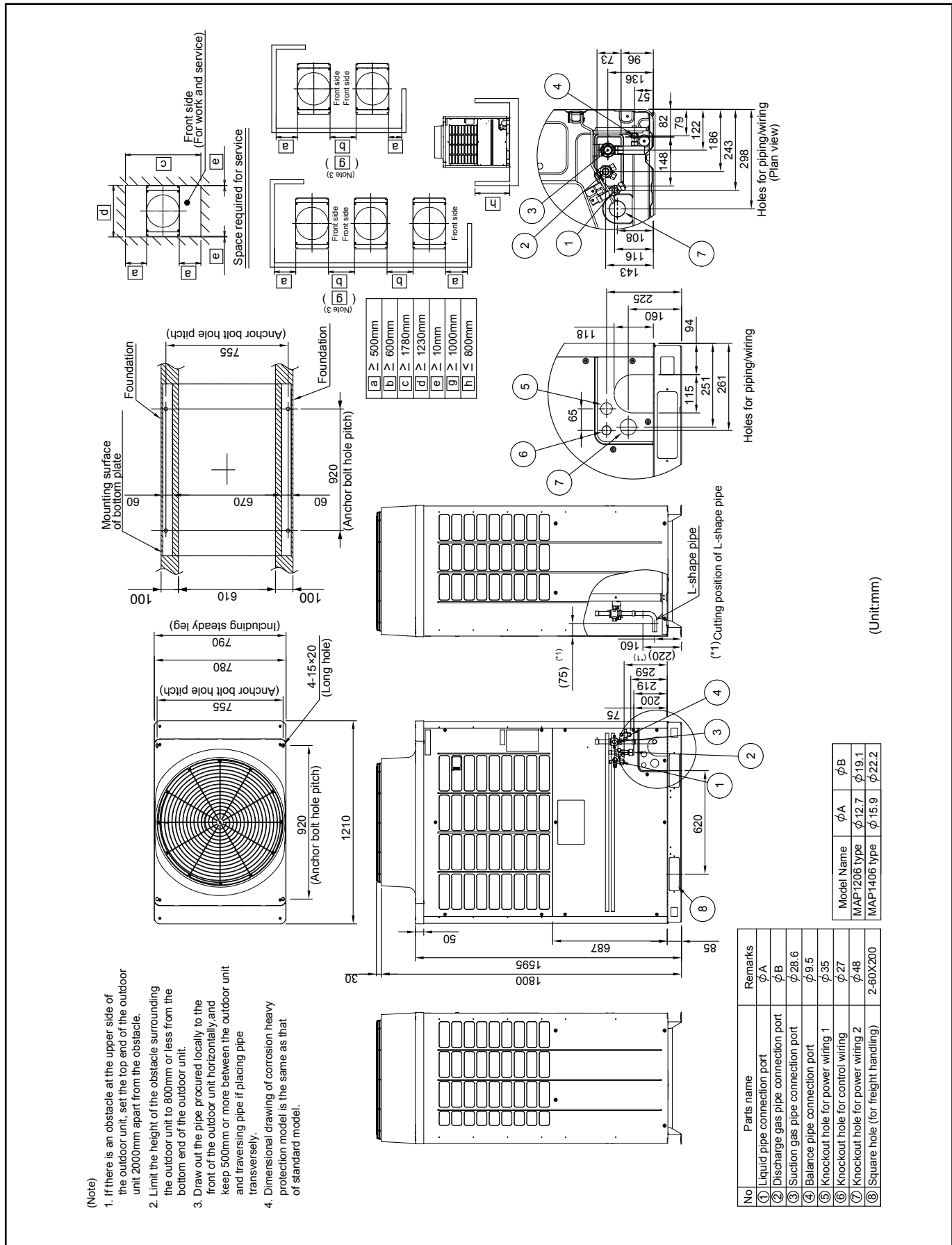
1. Not suitable for applications, which require precise room temperature control, due to increased risk of indoor ON/OFF control and potential low air off temperatures.

2. For areas that do demand a precise room temperature control, we would recommend the installation of a secondary system, which has been designed solely for the purpose of low ambient cooling.

(*8) Under centralized control maximum 54 unit.

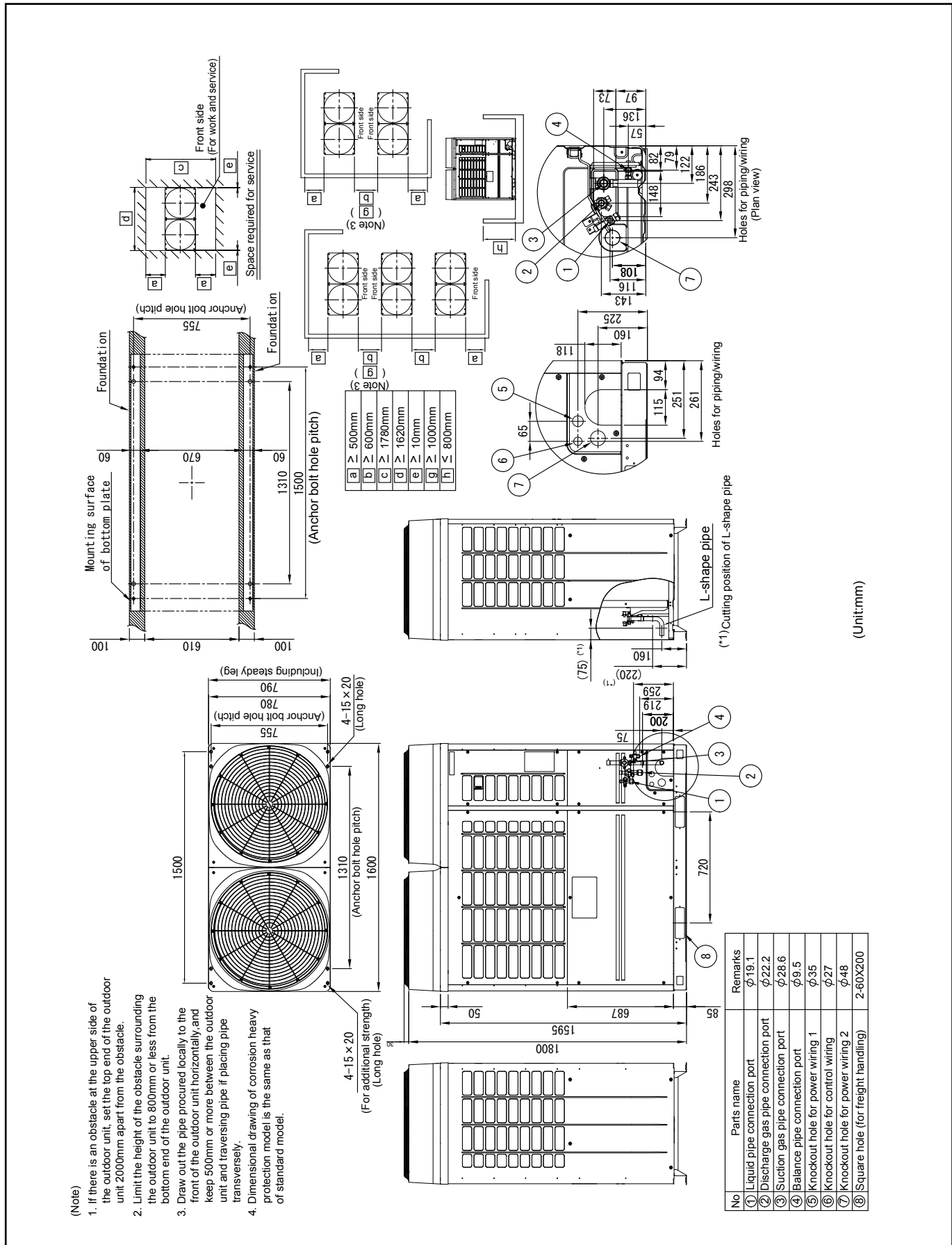
Single unit

Model : MMY-MAP1206FT8P-E, MAP1406FT8P-E



Single unit

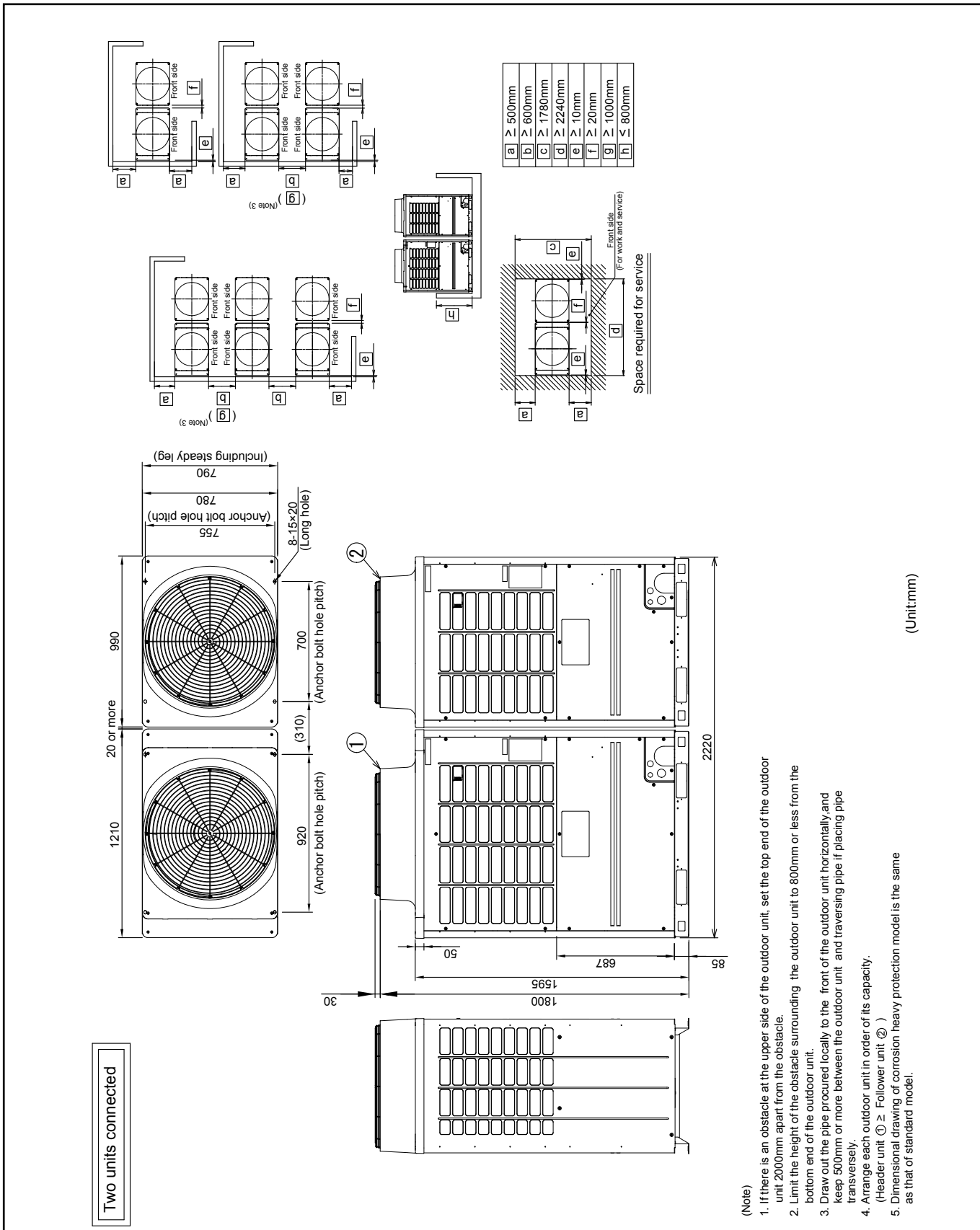
Model : MMY-MAP1608FT8P-E, MAP1806FT8P-E, MAP2006FT8P-E





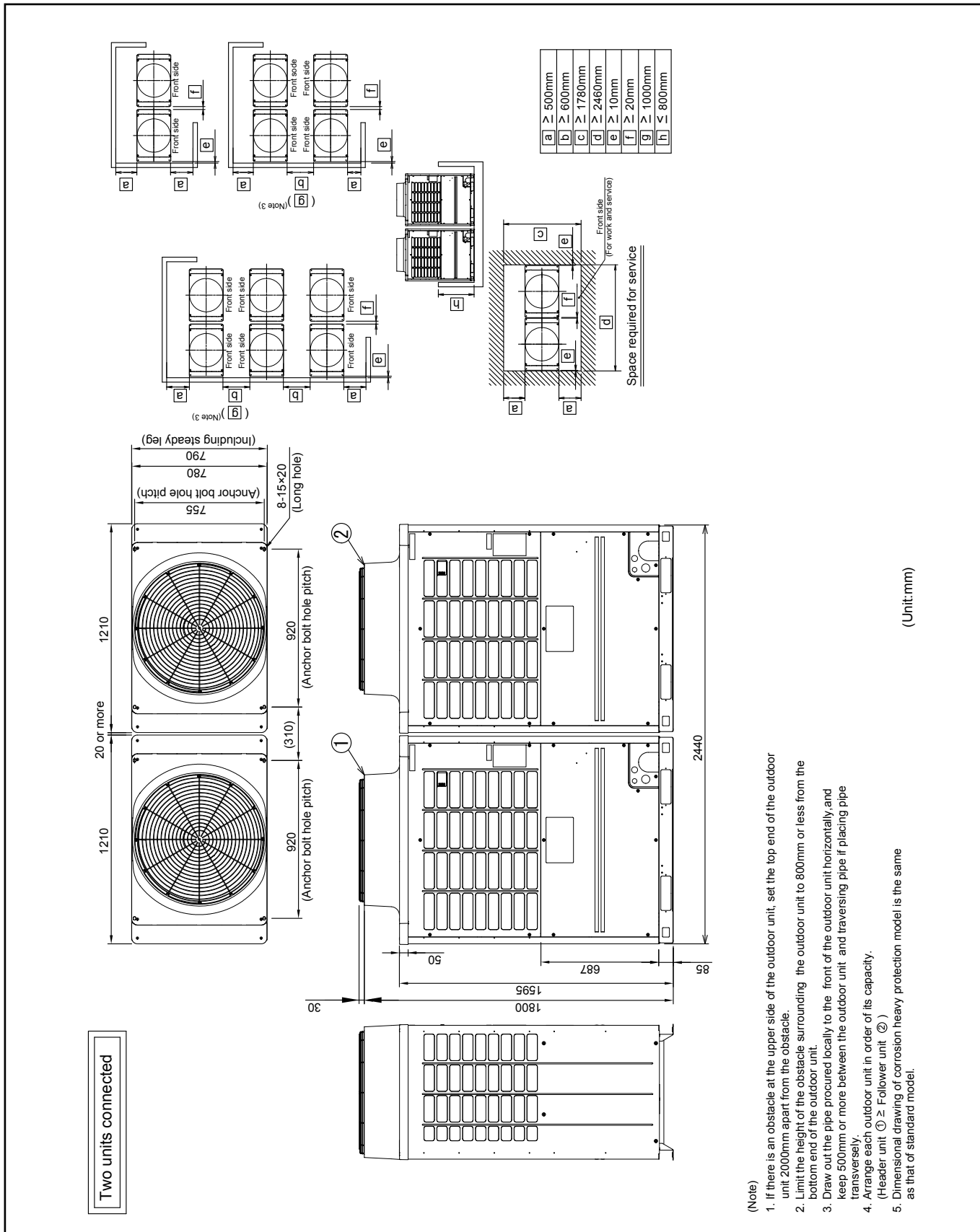
Combination

Model	Outdoor unit	
	(1) Header unit	(2) Follower unit
MMY-AP2216FT8P-E	MMY-MAP1206FT8P-E	MMY-MAP1006FT8P-E
MMY-AP2416FT8P-E	MMY-MAP1406FT8P-E	MMY-MAP1006FT8P-E



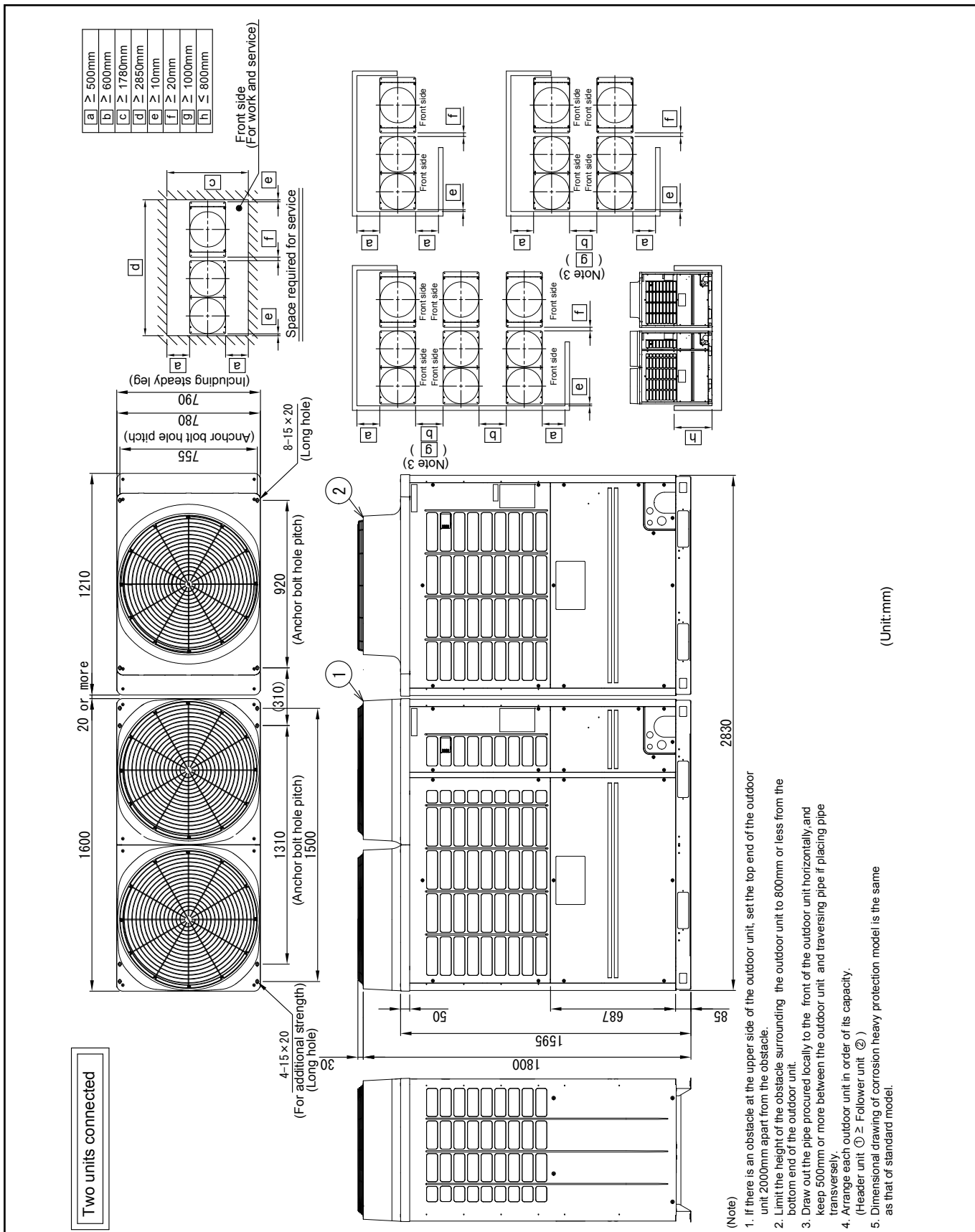
Combination

Model	Outdoor unit	
	(1) Header unit	(2) Follower unit
MMY-AP2616FT8P-E	MMY-MAP1406FT8P-E	MMY-MAP1206FT8P-E
MMY-AP2816FT8P-E	MMY-MAP1406FT8P-E	MMY-MAP1406FT8P-E



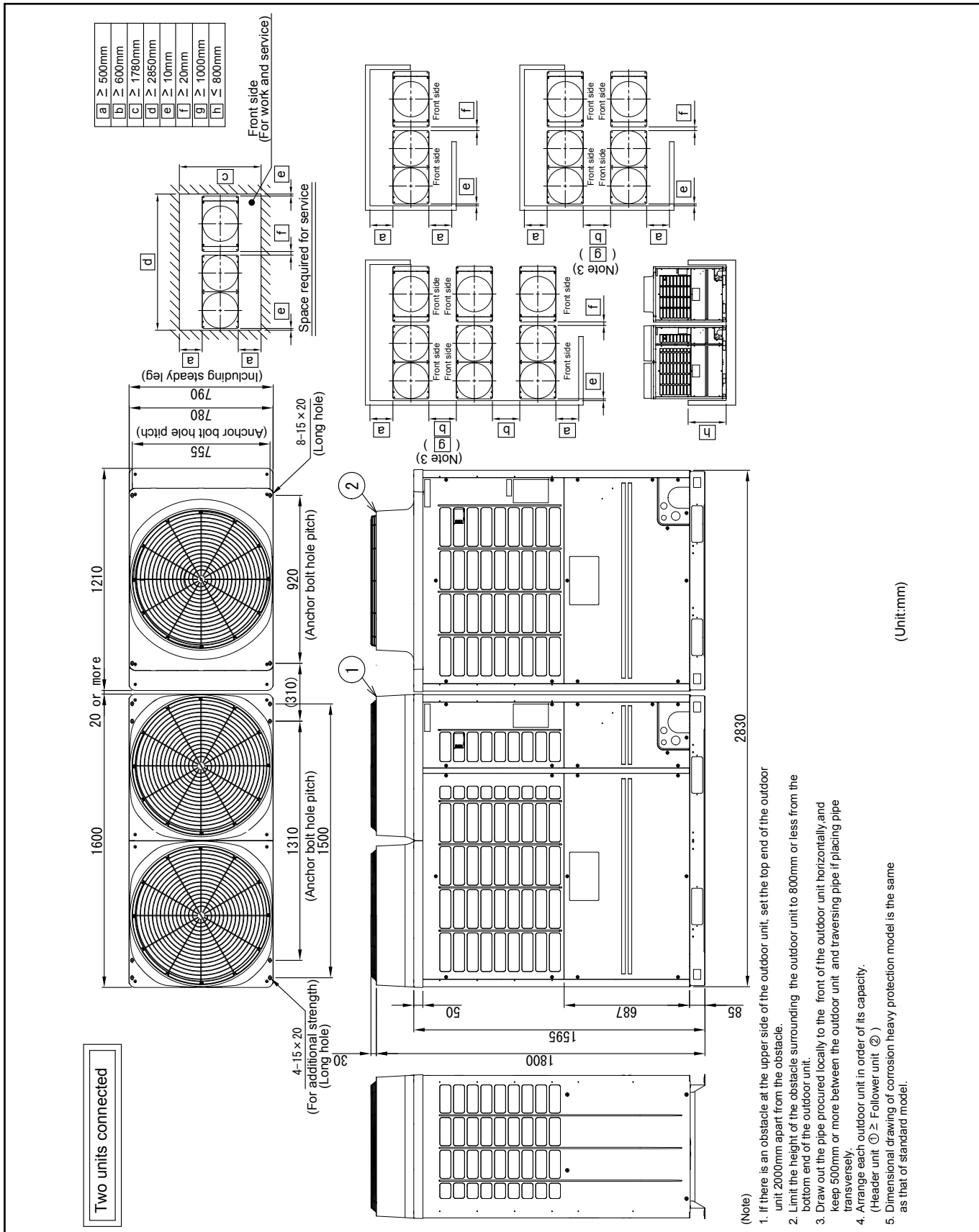
Combination

Model	Outdoor unit	
	(1) Header unit	(2) Follower unit
MMY-AP3016FT8P-E	MMY-MAP1606FT8P-E	MMY-MAP1406FT8P-E
MMY-AP3216FT8P-E	MMY-MAP1806FT8P-E	MMY-MAP1406FT8P-E



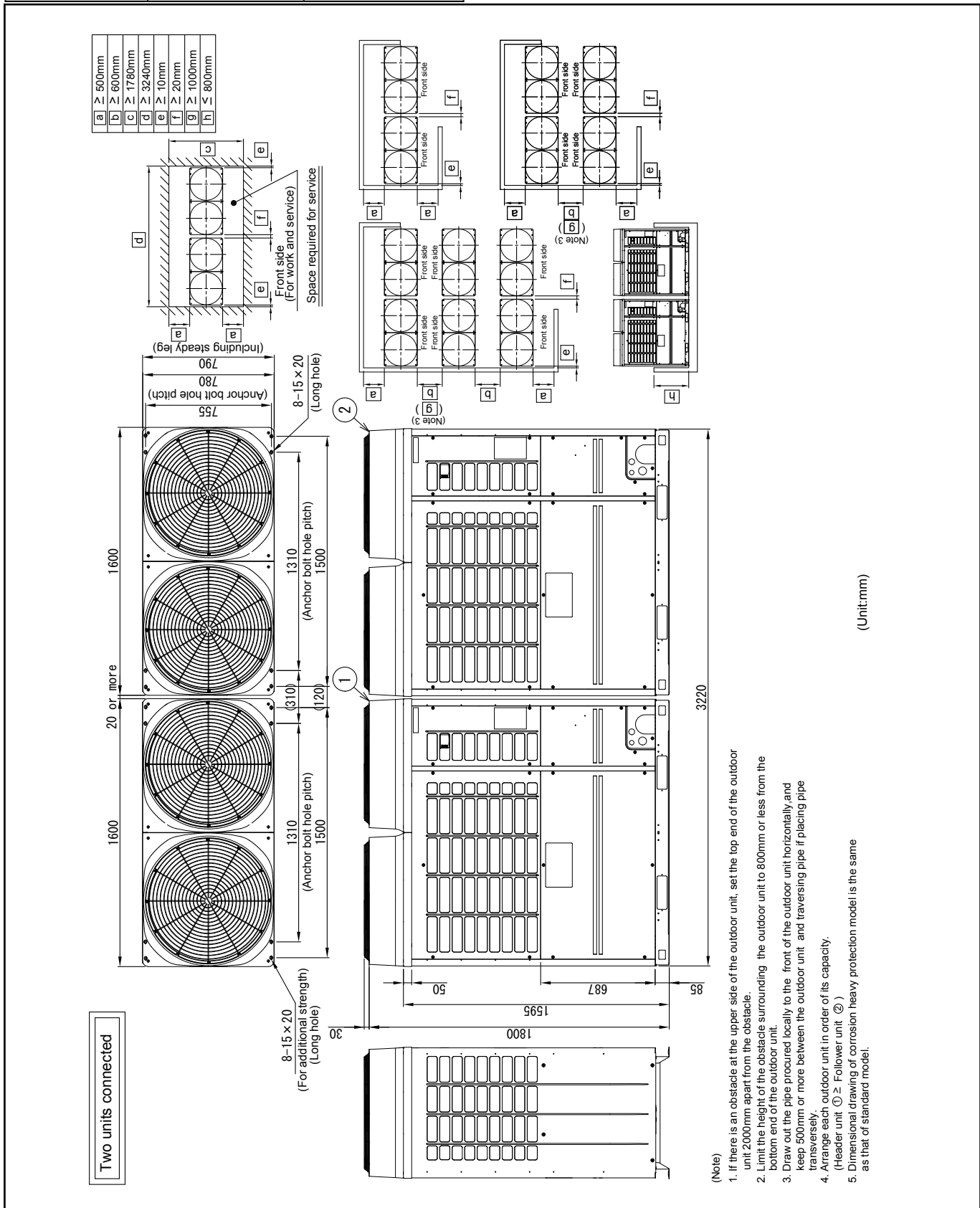
Combination

Model	Outdoor unit	
	(1) Header unit	(2) Follower unit
MMY-AP3016FT8P-E	MMY-MAP1606FT8P-E	MMY-MAP1406FT8P-E
MMY-AP3216FT8P-E	MMY-MAP1806FT8P-E	MMY-MAP1406FT8P-E



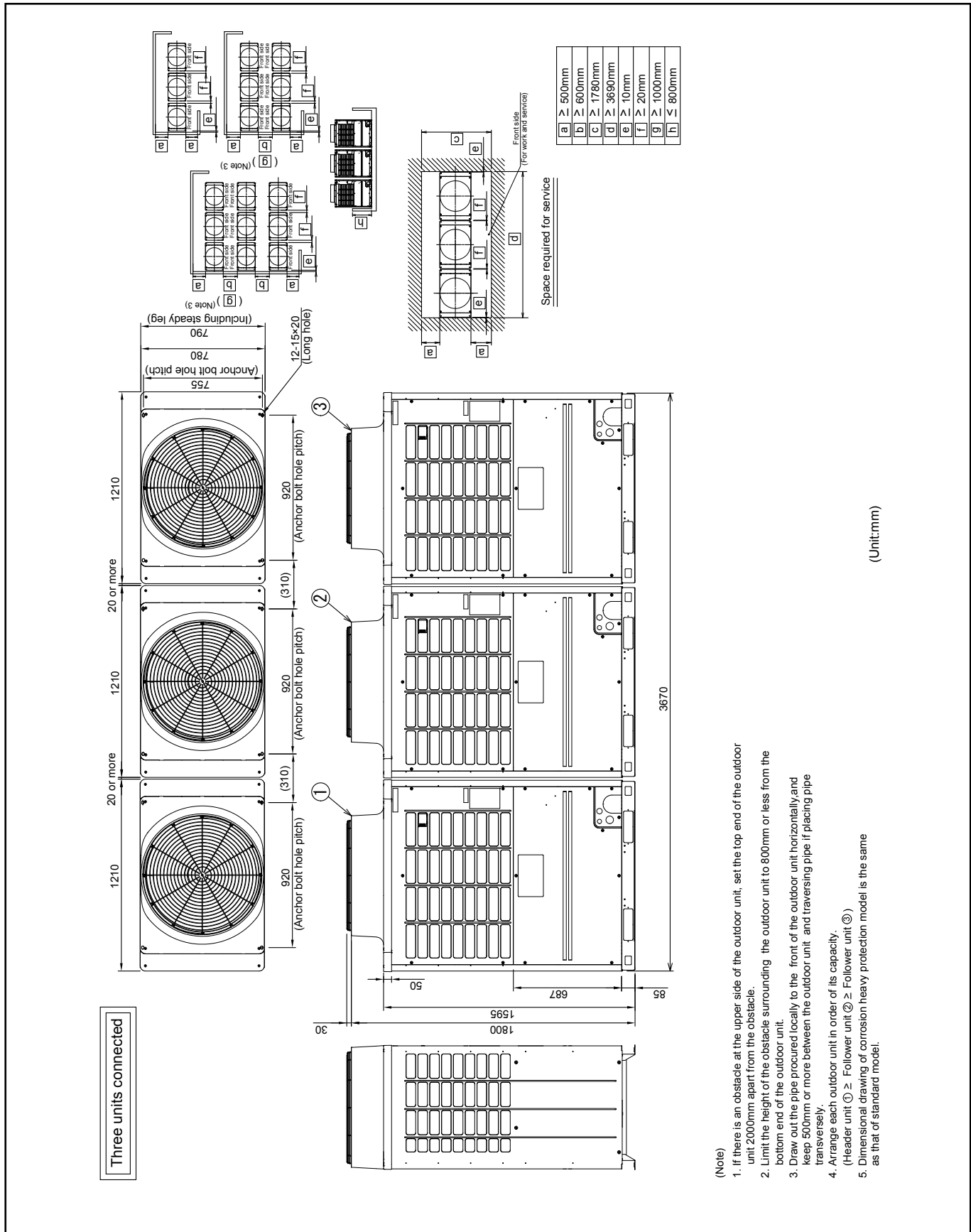
Combination

Model	Outdoor unit	
	(1) Header unit	(2) Follower unit
MMY-AP3416FT8P-E	MMY-MAP1806FT8P-E	MMY-MAP1606FT8P-E
MMY-AP3616FT8P-E	MMY-MAP1806FT8P-E	MMY-MAP1806FT8P-E
MMY-AP3816FT8P-E	MMY-MAP2006FT8P-E	MMY-MAP1806FT8P-E
MMY-AP4016FT8P-E	MMY-MAP2006FT8P-E	MMY-MAP2006FT8P-E



Combination

Model	Outdoor unit		
	(1) Header unit	(2) Follower unit	(3) Follower unit
MMY-AP4216FT8P-E	MMY-MAP1406FT8P-E	MMY-MAP1406FT8P-E	MMY-MAP1406FT8P-E

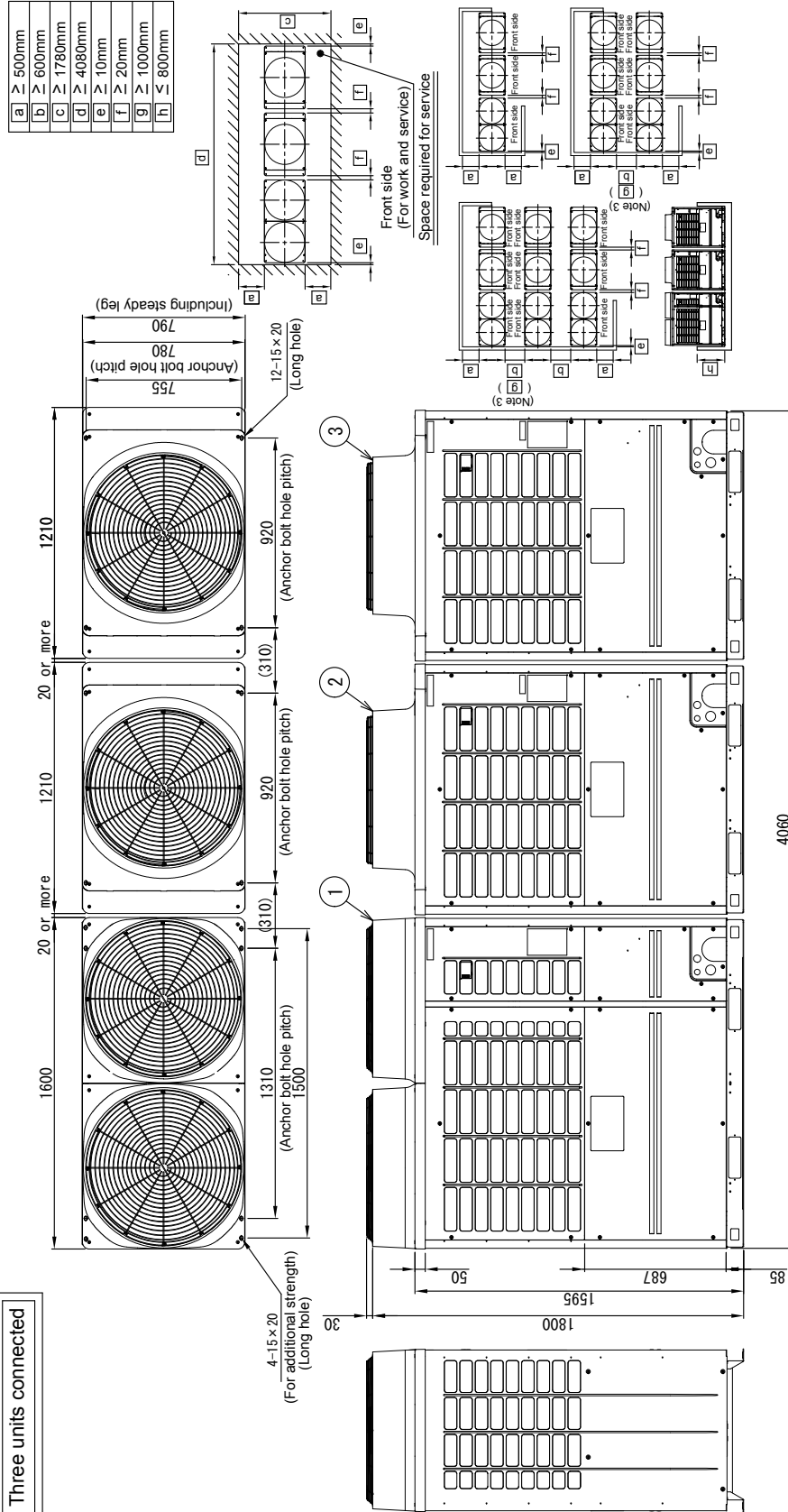




Combination

Model	Outdoor unit		
	(1) Header unit	(2) Follower unit	(3) Follower unit
MMY-AP4416FT8P-E	MMY-MAP1406FT8P-E	MMY-MAP1406FT8P-E	MMY-MAP1406FT8P-E
MMY-AP4616FT8P-E	MMY-MAP1806FT8P-E	MMY-MAP1406FT8P-E	MMY-MAP1406FT8P-E

a	≥ 500mm
b	≥ 600mm
c	≥ 1780mm
d	≥ 4080mm
e	≥ 10mm
f	≥ 20mm
g	≥ 1000mm
h	≥ 800mm

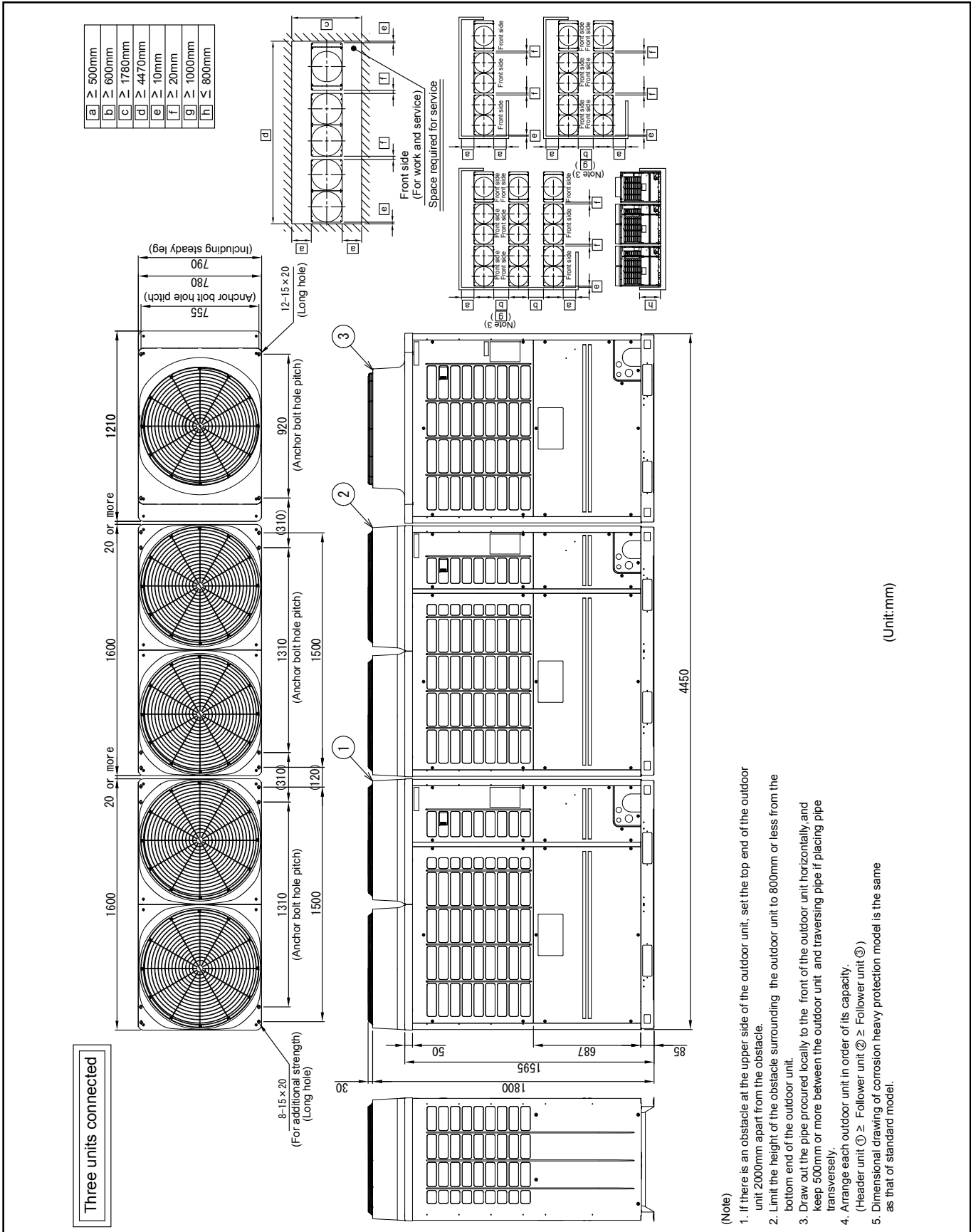


- (Note)
1. If there is an obstacle at the upper side of the outdoor unit, set the top end of the outdoor unit 2000mm apart from the obstacle.
 2. Limit the height of the obstacle surrounding the outdoor unit to 800mm or less from the bottom end of the outdoor unit.
 3. Draw out the pipe procured locally to the front of the outdoor unit horizontally, and keep 500mm or more between the outdoor unit and traversing pipe if placing pipe transversely.
 4. Arrange each outdoor unit in order of its capacity.
(Header unit ① ≥ Follower unit ② ≥ Follower unit ③)
 5. Dimensional drawing of corrosion heavy protection model is the same as that of standard model.



Combination

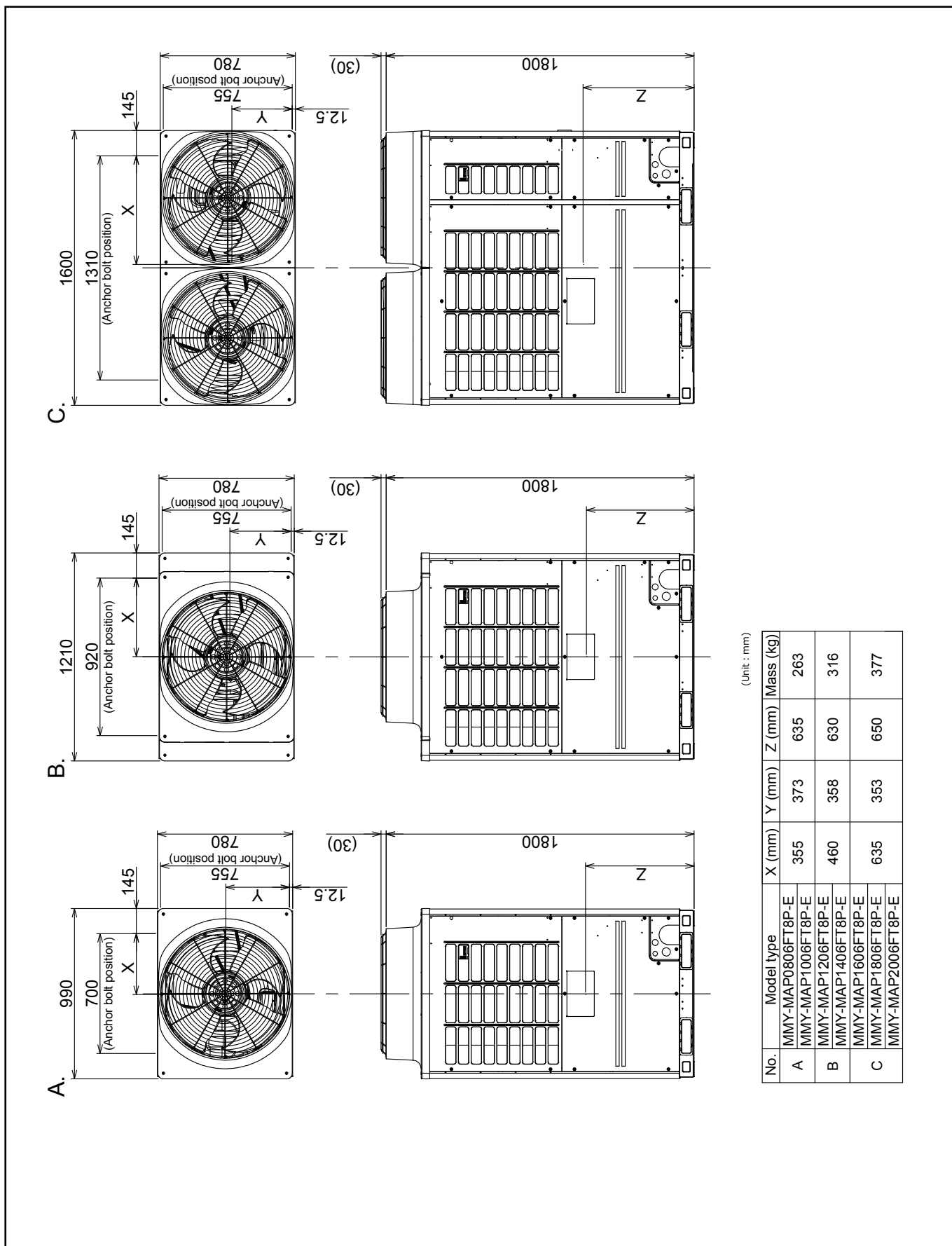
Model	Outdoor unit		
	(1) Header unit	(2) Follower unit	(3) Follower unit
MMY-AP4816FT8P-E	MMY-MAP1806FT8P-E	MMY-MAP1606FT8P-E	MMY-MAP1406FT8P-E
MMY-AP5016FT8P-E	MMY-MAP1806FT8P-E	MMY-MAP1806FT8P-E	MMY-MAP1406FT8P-E



- (Note)
1. If there is an obstacle at the upper side of the outdoor unit, set the top end of the outdoor unit 2000mm apart from the obstacle.
 2. Limit the height of the obstacle surrounding the outdoor unit to 800mm or less from the bottom end of the outdoor unit.
 3. Draw out the pipe procured locally to the front of the outdoor unit horizontally, and keep 500mm or more between the outdoor unit and traversing pipe if placing pipe transversely.
 4. Arrange each outdoor unit in order of its capacity.
(Header unit ① ≥ Follower unit ② ≥ Follower unit ③)
 5. Dimensional drawing of corrosion heavy protection model is the same as that of standard model.

(Unit:mm)

5.3 Center of gravity



(Unit : mm)

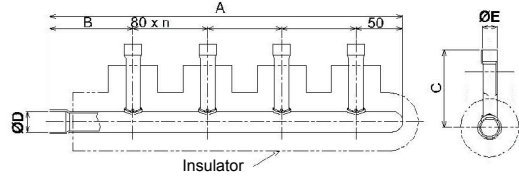
No.	Model type	X (mm)	Y (mm)	Z (mm)	Mass (kg)
A	MMY-MAP0806FT8P-E	355	373	635	263
	MMY-MAP1006FT8P-E	460	358	630	316
	MMY-MAP1406FT8P-E	635	353	650	377
B	MMY-MAP1606FT8P-E				
	MMY-MAP1806FT8P-E				
C	MMY-MAP2006FT8P-E				

5-4. Branch header / branch joint

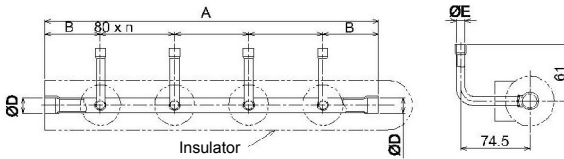
• Branch header

RBM-HY1043FE, HY1083FE, HY2043FE, HY2083FE (For 3 piping)

Suction gas side, Discharge gas side



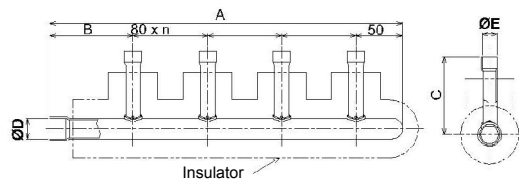
Liquid side



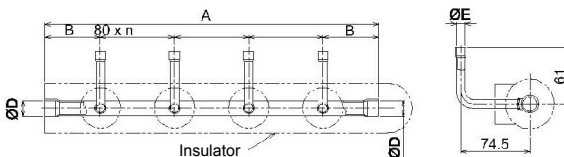
Model		A	B	C	øD	øE	n	Accessory socket Q'ty	Sealed pipe
RBM-HY1043FE	Suction gas side	380	90	83.6	22.2	15.9	3	⑥x 3, ⑨x 4, ⑭x 1, ⑰x 1	ø 15.9 x 1
	Discharge gas side	380	90	83.6	22.2	15.9	3	⑥x 4, ⑨x 4, ⑱x 1, ⑳x 1	ø 15.9 x 3
	Liquid side	330	45	-	15.9	9.5	3	①x 4, ⑥x 1, ⑨x 1	ø 15.9 x 1, ø 9.5 x 1
RBM-HY1083FE	Suction gas side	700	90	83.6	22.2	15.9	7	⑥x 7, ⑨x 8, ⑭x 1, ⑰x 1	ø 15.9 x 3
	Discharge gas side	700	90	83.6	22.2	15.9	7	⑥x 8, ⑨x 8, ⑱x 1, ⑳x 1	ø 15.9 x 7
	Liquid side	650	45	-	15.9	9.5	7	①x 8, ⑥x 1, ⑨x 1	ø 15.9 x 1, ø 9.5 x 3
RBM-HY2043FE	Suction gas side	385.5	95.5	89.3	31.8	15.9	3	⑥x 2, ⑨x 2, ⑳x 1, ㉑x 1	ø 15.9 x 1
	Discharge gas side	380	90	83.6	22.2	15.9	3	⑨x 4, ⑰x 1	ø 15.9 x 3
	Liquid side	330	45	-	15.9	9.5	3	①x 2, ⑤x 1	ø 15.9 x 1, ø 9.5 x 1
RBM-HY2083FE	Suction gas side	705.5	95.5	89.3	31.8	15.9	7	⑥x 7, ⑨x 7, ⑳x 1, ㉑x 1	ø 15.9 x 3
	Discharge gas side	700	90	83.6	22.2	15.9	7	⑨x 8, ⑰x 1	ø 15.9 x 7
	Liquid side	650	45	-	15.9	9.5	7	①x 7, ⑤x 1	ø 15.9 x 1, ø 9.5 x 3

RBM-HY1043E, HY1083E, HY2043E, HY2083E (For 2 piping)

Gas side



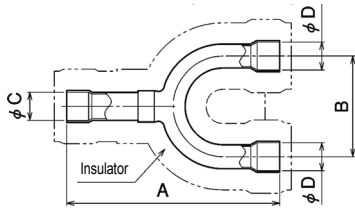
Liquid side



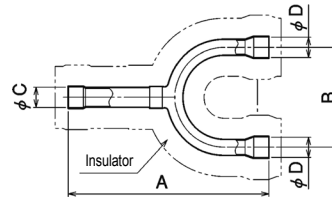
Model		A	B	C	øD	øE	n	Accessory socket Q'ty	Sealed pipe
RBM-HY1043E	Gas side	380	90	83.6	22.2	15.9	3	⑥x 4, ⑨x 4, ⑭x 1, ⑱x 1, ⑰x 1	ø 15.9 x 1
	Liquid side	360	60	-	15.9	9.5	3	①x 4, ⑥x 1, ⑨x 1	ø 15.9 x 1, ø 9.5 x 1
RBM-HY1083E	Gas side	700	90	83.6	22.2	15.9	7	⑥x 8, ⑨x 8, ⑭x 1, ⑱x 1, ⑰x 1	ø 15.9 x 3
	Liquid side	680	60	-	15.9	9.5	7	①x 8, ⑥x 1, ⑨x 1	ø 15.9 x 1, ø 9.5 x 3
RBM-HY2043E	Gas side	385.5	95.5	89.3	31.8	15.9	3	⑥x 2, ⑨x 2, ⑳x 1, ㉑x 1	ø 15.9 x 1
	Liquid side	360	60	-	15.9	9.5	3	①x 2	ø 15.9 x 1, ø 9.5 x 1
RBM-HY2083E	Gas side	705.5	95.5	89.3	31.8	15.9	7	⑥x 7, ⑨x 7, ⑳x 1, ㉑x 1	ø 15.9 x 3
	Liquid side	680	60	-	15.9	9.5	7	①x 7	ø 15.9 x 1, ø 9.5 x 3

• Y-shape branch joint
 RBM-BY55FE, BY105FE, BY205FE, BY305FE (For 3 piping)

Suction gas side, Discharge gas side



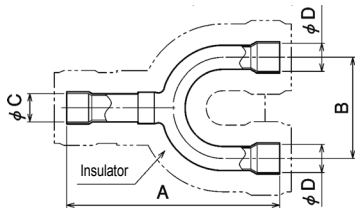
Liquid side



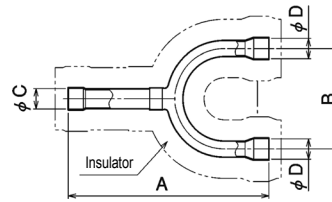
Model		A	B	øC	øD	Accessory socket Q'ty	Sealed pipe
RBM-BY55FE	Suction gas side	160	80	15.9	15.9	⑨x 2	
	Discharge gas side	160	80	15.9	15.9	⑨x 3	ø 12.7 x 1
	Liquid side	130	70	9.5	9.5	①x 2	
RBM-BY105FE	Suction gas side	170	80	22.2	22.2	⑭x 2, ⑦⑩x 2, ⑨①x 1	
	Discharge gas side	170	80	22.2	22.2	⑩x 1, ⑨③x 1	ø 12.7 x 1
	Liquid side	160	80	15.9	15.9	⑨x 1, ⑨①x 1, ⑨②x 1	
RBM-BY205FE	Suction gas side	200	80	31.8	28.6	⑩⑥x 1, ②⑦x 1, ④③x 2, ⑤⑨x 1, ⑤⑨x 1, ⑨①x 1	
	Discharge gas side	170	80	22.2	22.2	⑩x 2, ⑦⑩x 2, ⑨③x 1	ø 12.7 x 1
	Liquid side	160	80	15.9	15.9	⑨x 1, ⑤①x 1, ⑨②x 1	
RBM-BY305FE	Suction gas side	220	80	38.1	38.1	④③x 1, ⑥①x 3, ⑥②x 2, ⑦①x 2, ⑦⑤x 1, ⑨①x 1	
	Discharge gas side	200	80	31.8	28.6	②⑦x 1, ④③x 2, ④⑨x 1, ⑤⑨x 1, ⑤⑨x 1, ⑨③x 1	ø 12.7 x 1
	Liquid side	170	80	22.2	22.2	⑭x 1, ⑩⑧x 1, ⑨②x 1, ⑨④x 1	

RBM-BY55E, BY105E, BY205E, BY305E (For 2 piping)

Gas side



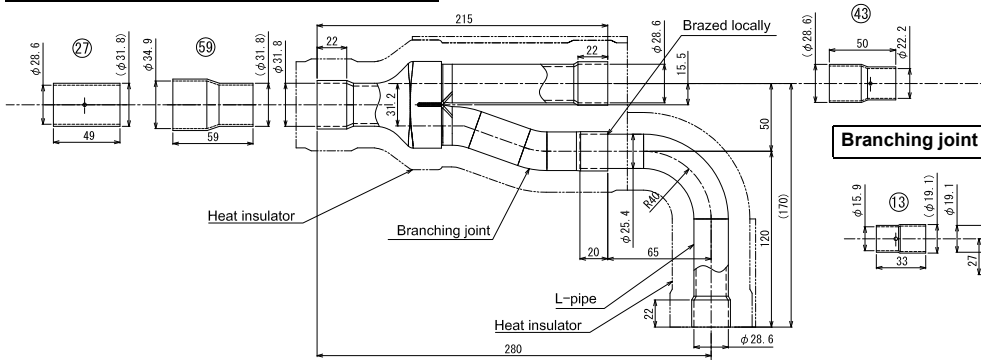
Liquid side



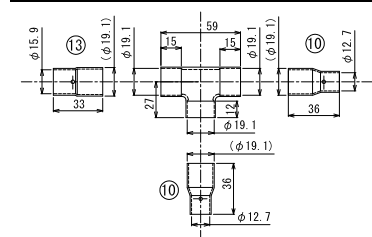
Model		A	B	øC	øD	Accessory socket Q'ty
RBM-BY55E	Gas side	160	80	15.9	15.9	⑨x 1, ⑤①x 2, ⑨①x 2
	Liquid side	130	70	9.5	9.5	①x 2
RBM-BY105E	Gas side	170	80	22.2	22.2	⑭x 2, ⑦⑩x 2, ⑨①x 1
	Liquid side	160	80	15.9	15.9	⑨x 1, ⑨①x 1, ⑨②x 1
RBM-BY205E	Gas side	200	80	31.8	28.6	⑩⑥x 1, ②⑦x 1, ④③x 2, ⑤⑨x 1, ⑤⑨x 1, ⑨①x 1
	Liquid side	160	80	15.9	15.9	⑨x 1, ⑤①x 2, ⑨②x 1
RBM-BY305E	Gas side	220	80	38.1	38.1	④③x 1, ⑥①x 3, ⑥②x 2, ⑦①x 2, ⑦⑤x 1, ⑨①x 1
	Liquid side	170	80	22.2	22.2	⑨②x 1, ⑨④x 3

• Branching joint for connection of outdoor units (Set of three kinds of joint)
RBM-BT14FE

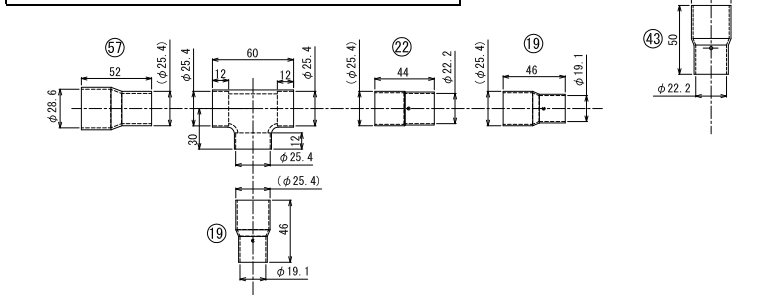
Branching joint (Suction gas side) and sockets



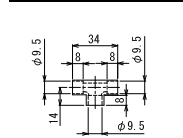
Branching joint (Liquid side) and sockets



Branching joint (Discharge gas side) and sockets

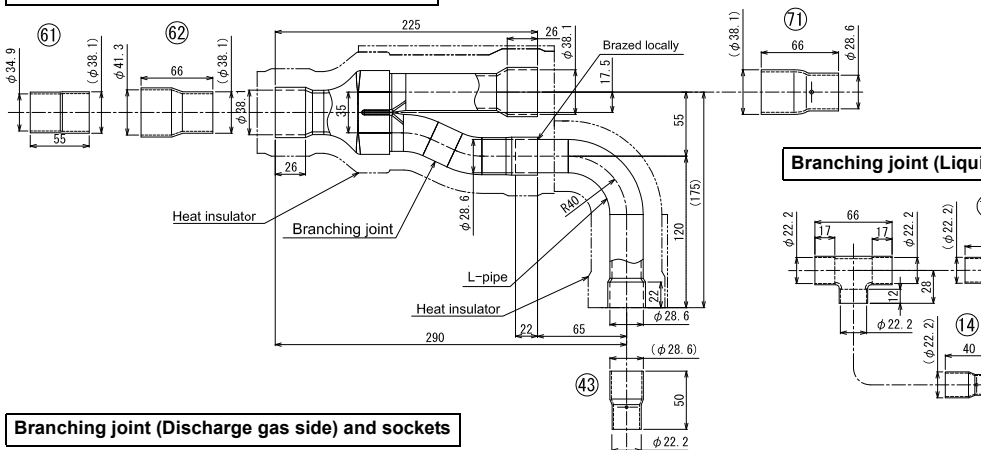


Balance pipe side

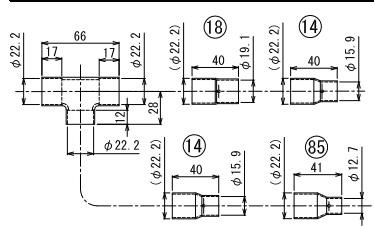


RBM-BT24FE

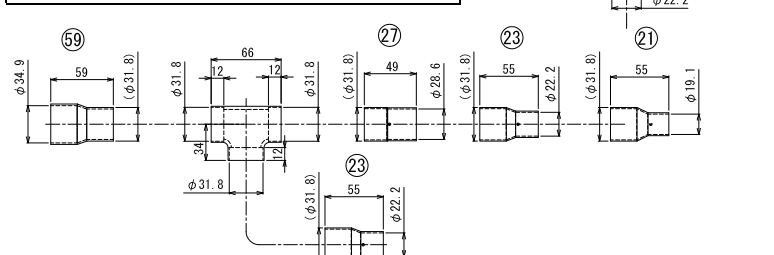
Branching joint (Suction gas side) and sockets



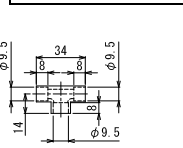
Branching joint (Liquid side) and sockets



Branching joint (Discharge gas side) and sockets



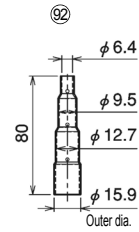
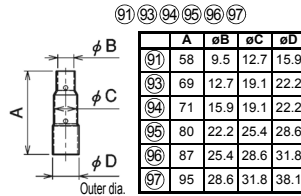
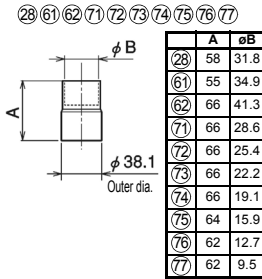
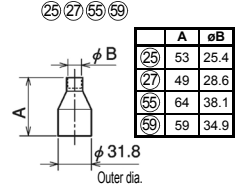
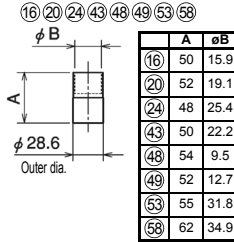
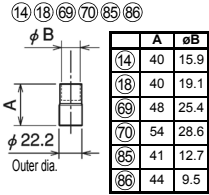
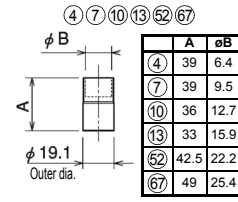
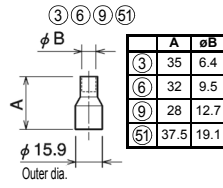
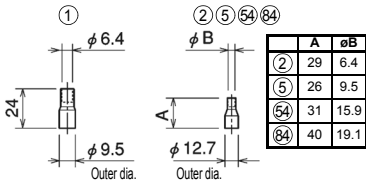
Balance pipe side



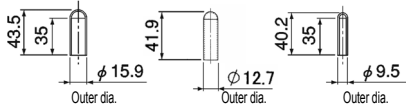
(Unit : mm)



• Accessory socket



Sealed pipe

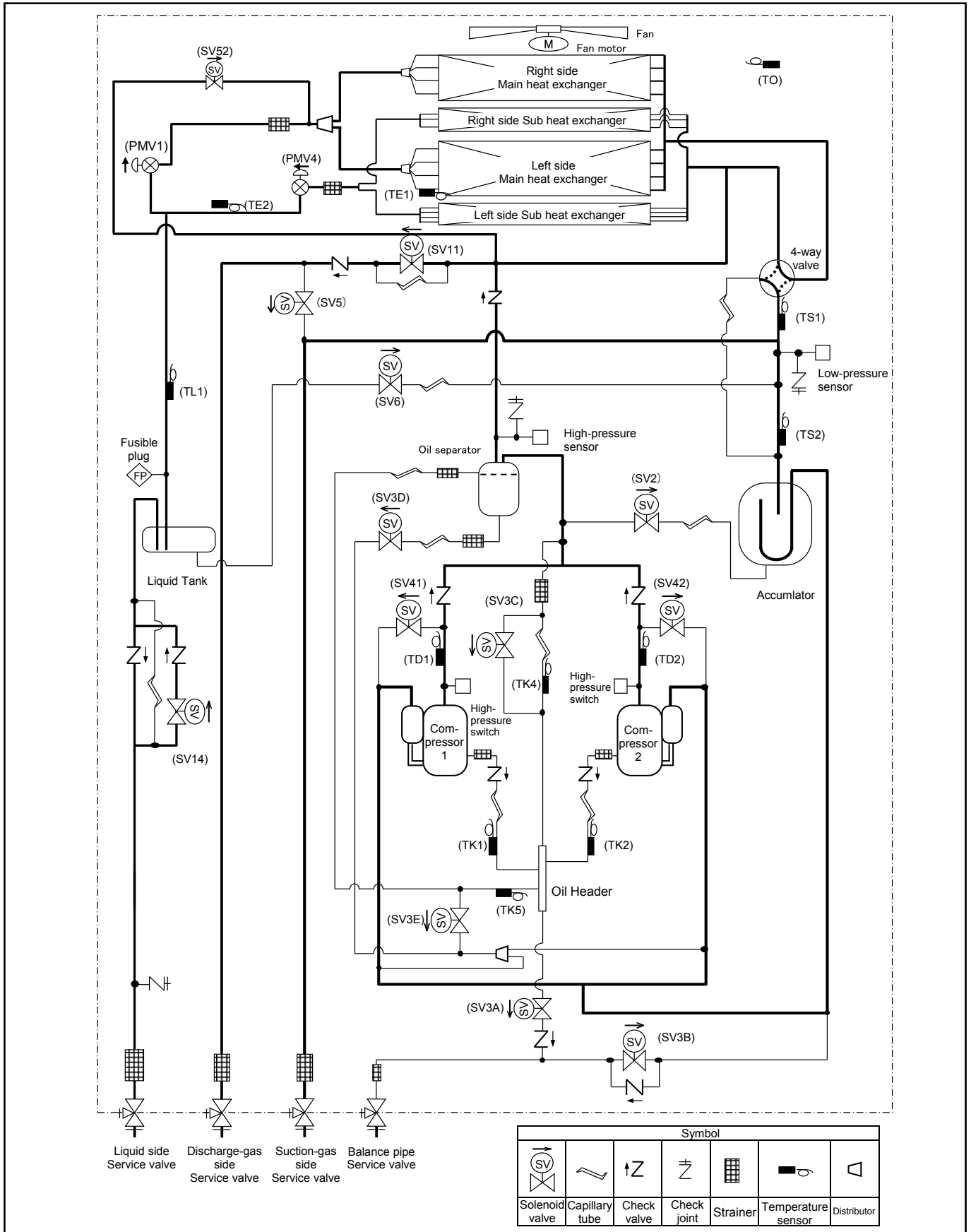


(Unit : mm)

5-5. Refrigerant cycle diagram

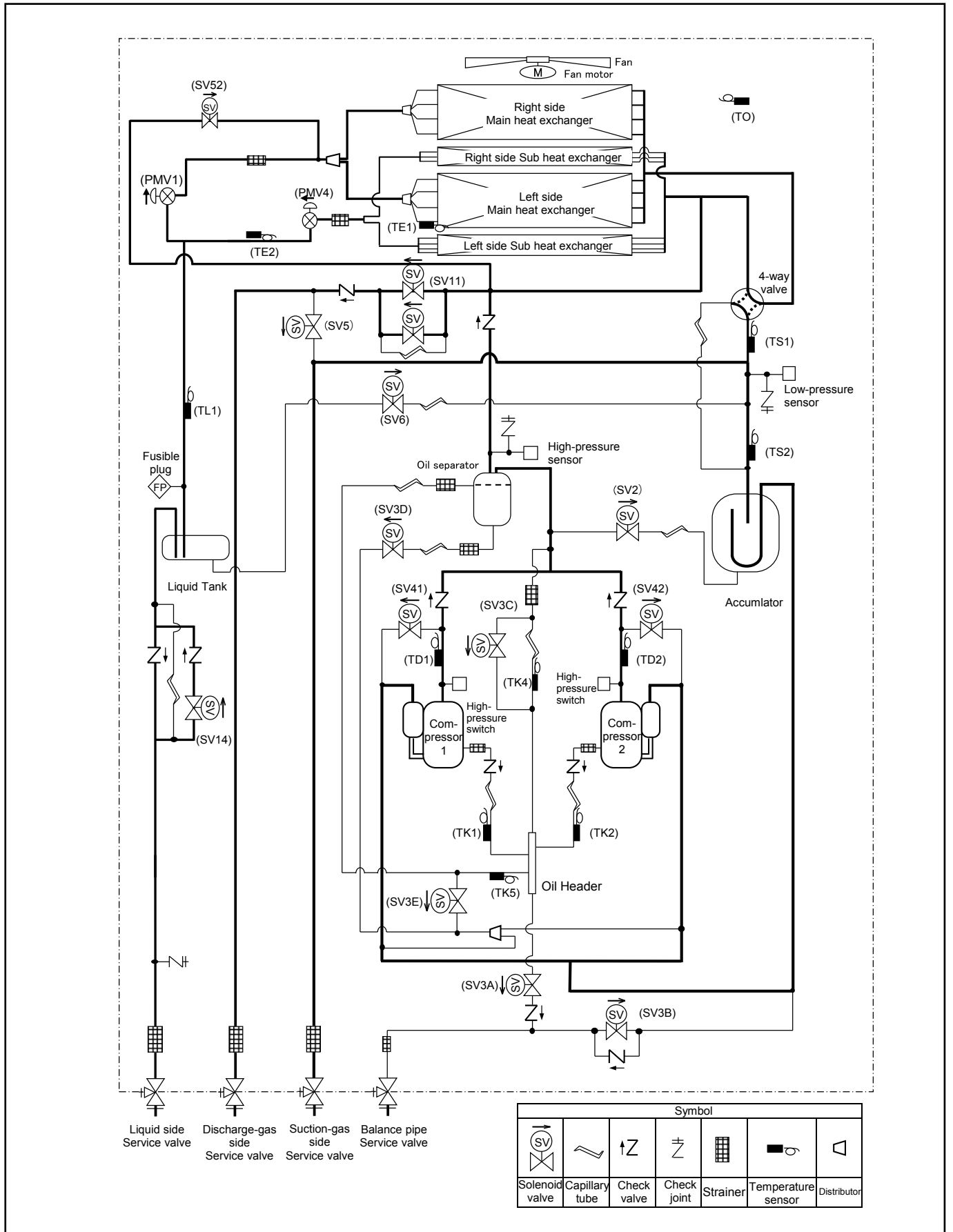
Outdoor Unit (8, 10HP)

Model : MMY-MAP0806FT8P-E, MMY-MAP1006FT8P-E



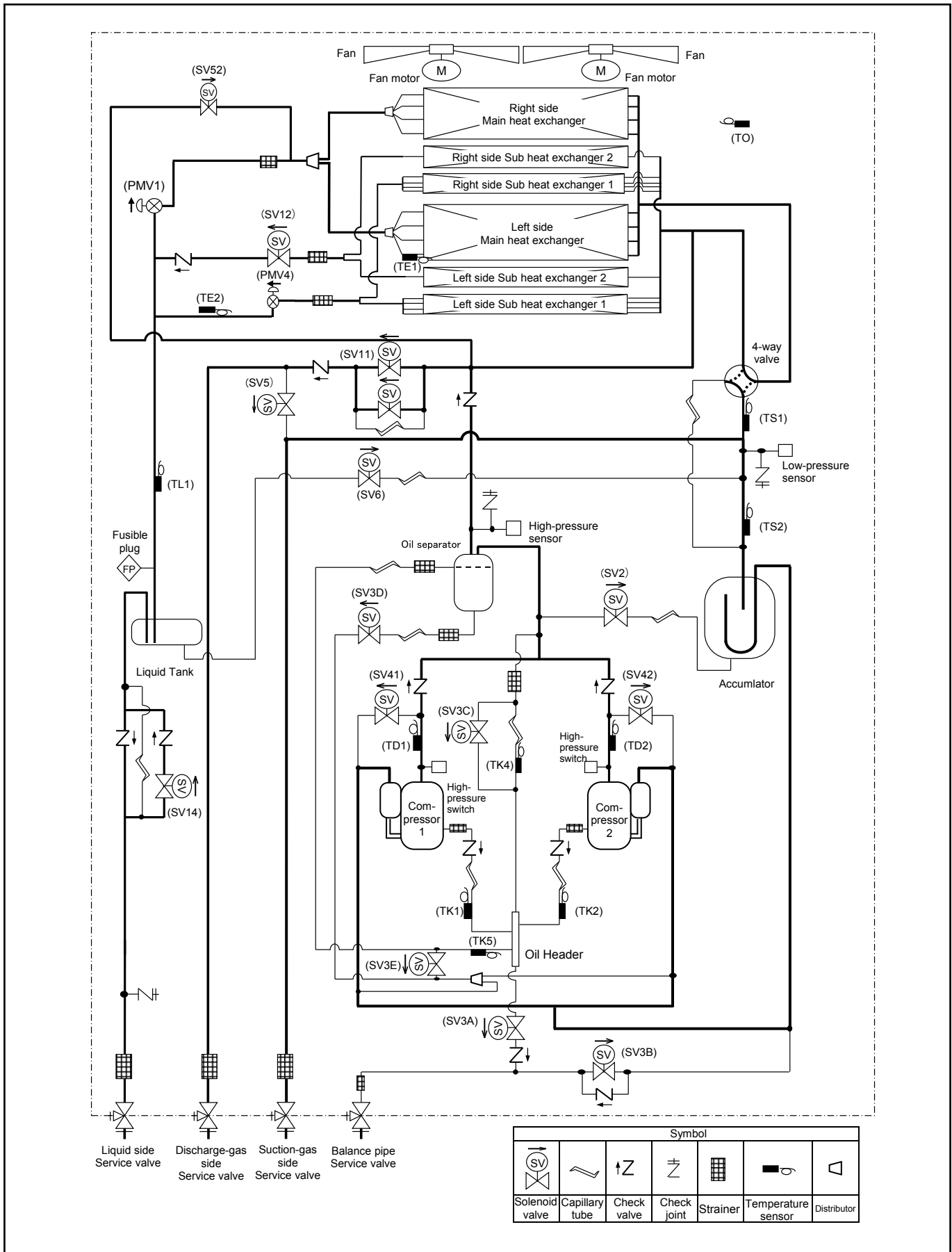
Outdoor Unit (12, 14HP)

Model : MMY-MAP1206FT8P-E , MMY-MAP1406FT8P-E



Outdoor Unit (16, 18, 20HP)

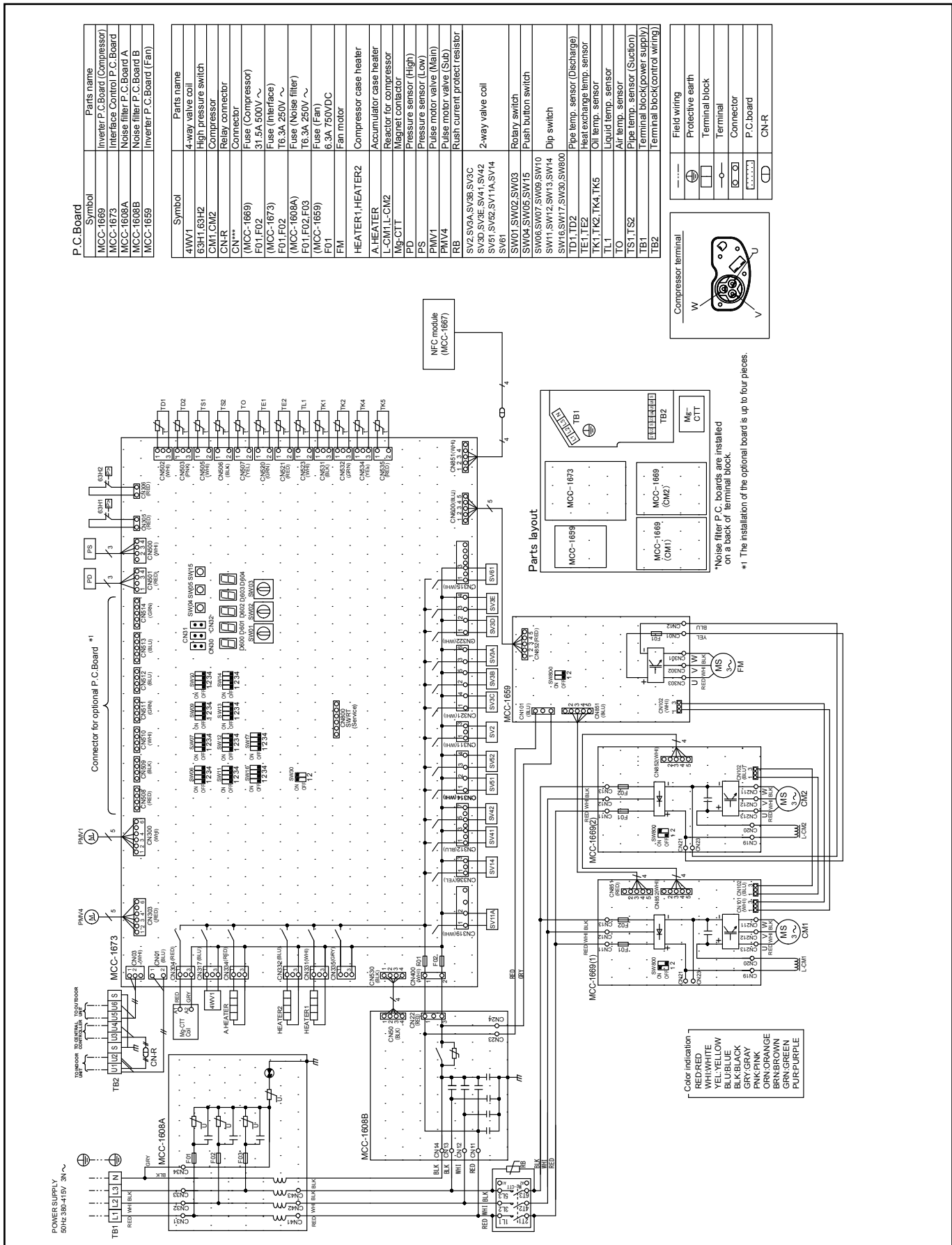
Model : MMY-MAP1606FT8P-E, MMY-MAP1806FT8P-E, MMY-MAP2006FT8P-E





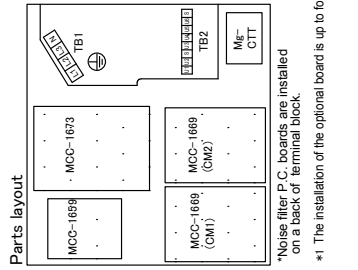
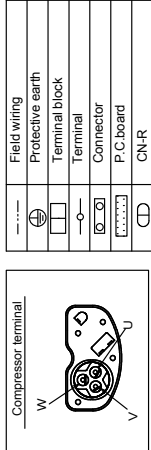
5-6. Wiring Diagrams

Model : MMY-MAP0806FT8P-E, MMY-MAP1006FT8P-E



Symbol	Parts name
MCC-1669	Inverter P.C. Board (Compressor)
MCC-1673	Interface Control P.C. Board
MCC-1689A	Noise filter P.C. Board A
MCC-1689B	Noise filter P.C. Board B
MCC-1699	Inverter P.C. Board (Fan)

Symbol	Parts name
4WV1	4-way valve coil
63H1, 63H2	High pressure switch
CM1, CM2	Compressor
CNR	Relay connector
CN1~CN16	Connector
(MCC-1669)	Fuse (Compressor)
F01, F02	31.5A 500V ~
(MCC-1673)	Fuse (Interface)
(MCC-1689A)	Fuse (Noise filter)
F01, F02, F03	T6.3A 250V ~
(MCC-1659)	Fuse (Fan)
F01	6.3A 750VDC
FM	Fan motor
HEATER1, HEATER2	Compressor case heater
A, HEATER	Accumulator case heater
L-CM1, L-CM2	Reactor for compressor
Mg-C1T	Magnet contactor
PS	Pressure sensor (High)
PMV1	Pressure sensor (Low)
PMV4	Pulse motor valve (Main)
RB	Pulse motor valve (Sub)
SV2, SV3A, SV3B, SV3C	Rush current protect resistor
SV3D, SV3E, SV41, SV42	2-way valve coil
SV51, SV52, SV11A, SV14	SV61
SW01, SW02, SW03	Rotary switch
SW04, SW05, SW15	Push button switch
SW06, SW07, SW09, SW10	Dip switch
SW11, SW12, SW13, SW14	Pipe temp. sensor (Discharge)
SW16, SW17, SW30, SW600	Heat exchange temp. sensor
TD1, TD2	Oil temp. sensor
TK1, TK2, TK4, TK5	Liquid temp. sensor
TL1	Air temp. sensor
TO	Pipe temp. sensor (Suction)
TS1, TS2	Terminal block (power supply)
TB1	Terminal block (control wiring)
TB2	Terminal block (control wiring)



*Noise filter P.C. boards are installed on a back of terminal block.
*1 The installation of the optional board is up to four pieces.

Color indication
RED: RED
WH: WHITE
YEL: YELLOW
BLU: BLUE
BLK: BLACK
GRY: GRAY
PNK: PINK
BRN: BROWN
GRN: GREEN
PUR: PURPLE

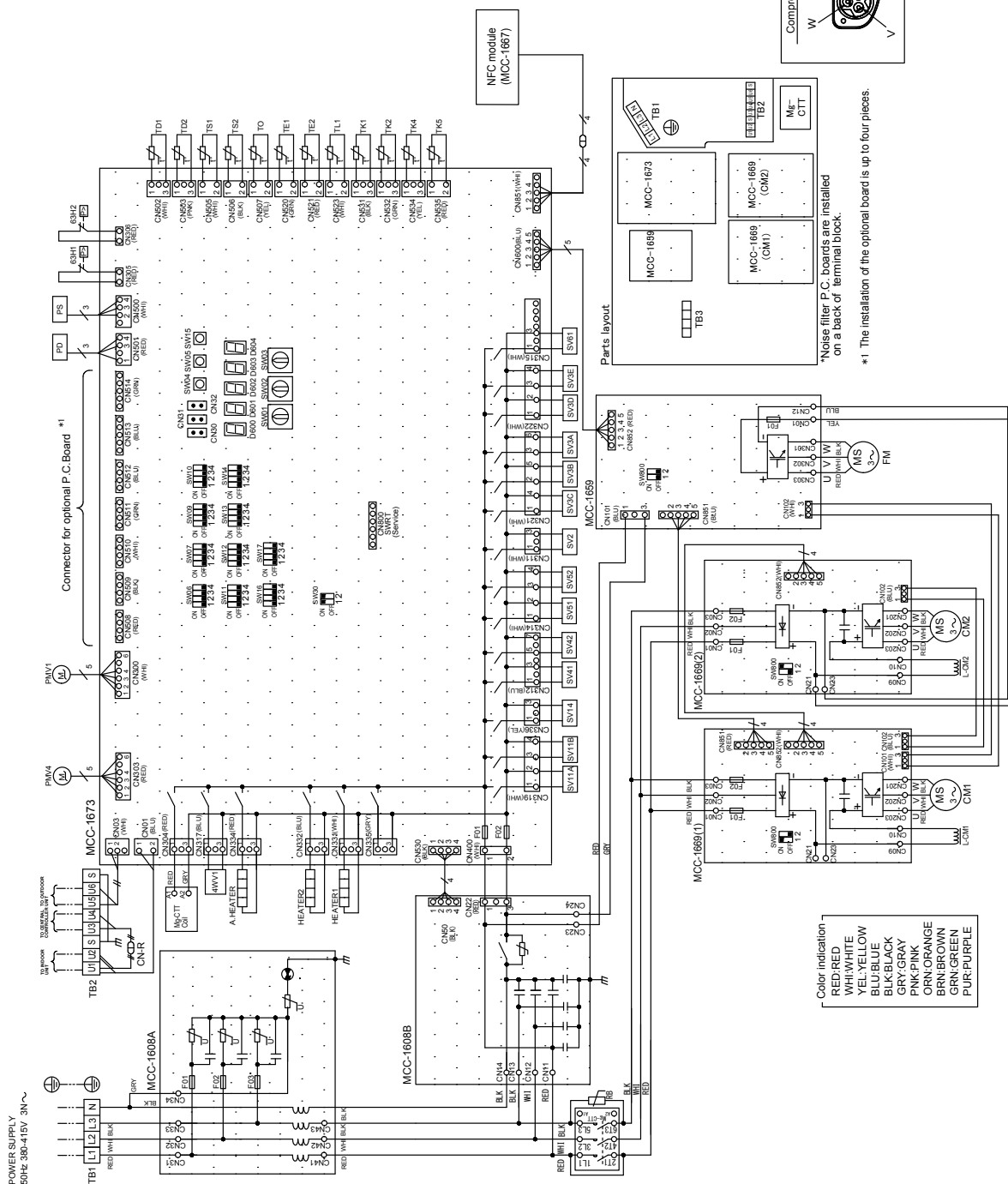
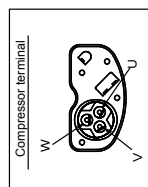


Model : MMY-MAP1206FT8P-E , MMY-MAP1406FT8P-E

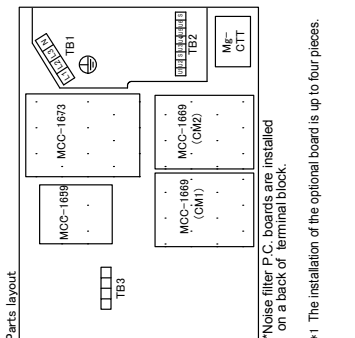
Symbol	Parts name
MCC-1669	Inverter P.C.Board (Compressor)
MCC-1673	Interface Control P.C. Board
MCC-1688A	Noise filter P.C. Board A
MCC-1688B	Noise filter P.C. Board B
MCC-1689	Inverter P.C. Board (Fan)

Symbol	Parts name
4M1	4-way valve coil
63H1.63H2	High pressure switch
CNT1.CM2	Compressor
CNR	Relay connector
CNR*	Connector
F01.F02	Fuse (Compressor) 31.5A 500V ~
F01.F02	Fuse (Interface) T6.3A 250V ~
(MCC-1673)	Fuse (Noise filter) T6.3A 250V ~
F01.F02.F03	Fuse (Fan) T6.3A 250V ~
(MCC-1689)	Fuse (Fan) 6.3A 750VDC
FM	Fan motor
HEATER1.HEATER2	Compressor case heater
A.HEATER	Accumulator case heater
L-CNT1.L-CM2	Reactor for compressor
Mgr.CTT	Magnet contactor
PD	Pressure sensor (High)
PS	Pressure sensor (Low)
PMV1	Pulse motor valve (Main)
PMV4	Pulse motor valve (Sub)
RB	Rush current protect resistor
SV2.SV3A.SV3B.SV3C	2-way valve coil
SV4D.SV4E.SV41.SV42	Rotary switch
SV51.SV52.SV114	Push button switch
SV1B.SV14.SV61	
SW01.SW02.SW03	
SW04.SW05.SW15	
SW06.SW07.SW09.SW10	
SW11.SW12.SW13.SW14	
SW16.SW17.SW30.SW600	
TD1.TD2	Pipe temp. sensor (Discharge)
TE1.TE2	Heat exchange temp. sensor
TK1.TK2.TK4.TK5	Oil temp. sensor
TL1	Liquid temp. sensor
TO	Air temp. sensor
TS1.TS2	Pipe temp. sensor (Suction)
TB1	Terminal block(power supply)
TB2	Terminal block(control wiring)
TB3	Terminal block(internal wiring connector)

	Field wiring
	Protective earth
	Terminal block
	Terminal
	Connector
	P.C. board
	CNR



Color indication
 RED:RED
 WHI:WHITE
 YEL:YELLOW
 BLU:BLUE
 BLK:BLACK
 GRY:GRAY
 PNK:PINK
 ORN:ORANGE
 BRN:BROWN
 GRN:GREEN
 PUR:PURPLE





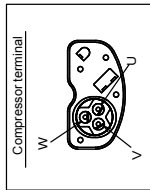
Model : MMY-MAP1606FT8P-E , MMY-MAP1806FT8P-E, MMY-MAP2006FT8P-E

P.C. Board	Symbol	Parts name
MCC-1660		Inverter P.C. Board (Compressor)
MCC-1673		Interface Control P.C. Board
MCC-1608A		Noise filter P.C. Board A
MCC-1608B		Noise filter P.C. Board B
MCC-1659		Inverter P.C. Board (Fan)

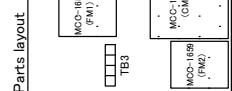
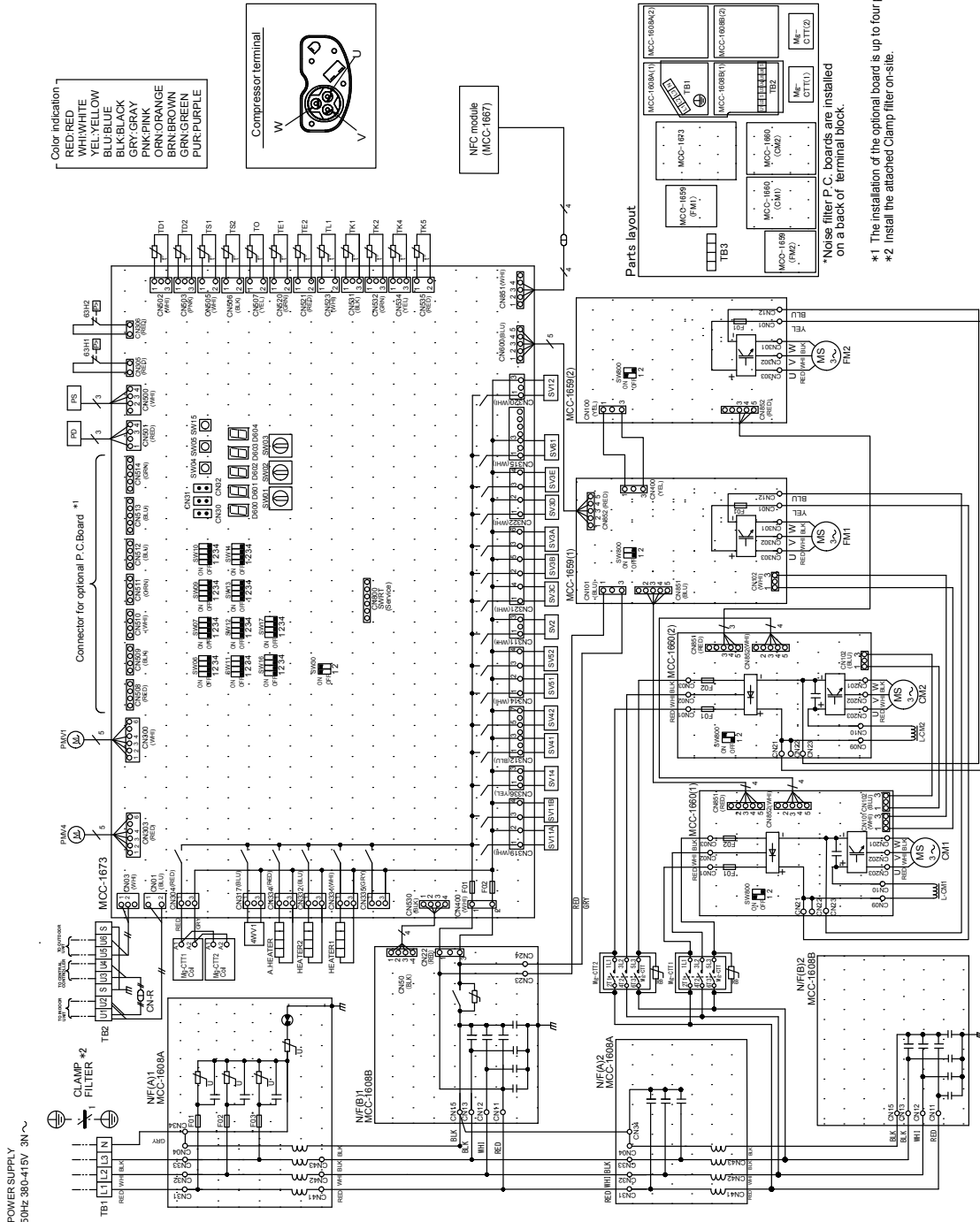
Symbol	Parts name
4WV1	4-way valve coil
63H1.63H2	High pressure switch
CM1.CM2	Compressor
CN-R	Relay connector
CN***	Connector
F01.F02	Fuse (Compressor)
(MCC-1660)	40A 500V ~
F01.F02	Fuse (Interface)
(MCC-1673)	T6.3A 250V ~
F01.F02	Fuse (Noise filter)
(MCC-1608A)	T6.3A 250V ~
F01	Fuse (Fan)
(MCC-1659)	6.3A 750VDC
FM1, FM2	Fan motor
HEATER1, HEATER2	Compressor case heater
A-HEATER	Accumulator case heater
L-CM1, L-CM2	Reactor for compressor
Mg-C1T1, Mg-C1T2	Magnet contactor
PD	Pressure sensor (High)
PS	Pressure sensor (Low)
PMV1	Pressure motor valve (Main)
PMV4	Pressure motor valve (Sub)
RB	Rush current protect resistor
SV2, SV3A, SV3B, SV3C	2-way valve coil
SV3D, SV2E, SV41, SV42	
SV51, SV62, SV11A	
SV11B, SV12, SV14, SV61	
SW01, SW02, SW03	Rotary switch
SW04, SW05, SW15	Push button switch
SW06, SW07, SW09, SW10	
SW11, SW12, SW13, SW14	
SW16, SW17, SW30, SW800	Dip switch
TD1, TD2	Pipe temp. sensor (Discharge)
TE1, TE2	Heat exchange temp. sensor
TK1, TK2, TK4, TK5	Oil temp. sensor
TL1	Liquid temp. sensor
TO	Air temp. sensor
TS1, TS2	Pipe temp. sensor (Suction)
TB1	Terminal block (power supply)
TB2	Terminal block (control wiring)
TB3	Terminal block (internal wiring connector)

—	Field wiring
⊕	Protective earth
□	Terminal block
○	Terminal
□	Connector
□	P.C. board
⊞	CN-R

Color indication
 RED: RED
 YEL: YEL
 BLK: BLK
 GRN: GRN
 BRN: BRN
 PUR: PUR



MCC module (MCC-1667)



*Noise filter P.C. boards are installed on a back of terminal block.
 *1 The installation of the optional board is up to four pieces.
 *2 Install the attached Clamp filter on-site.

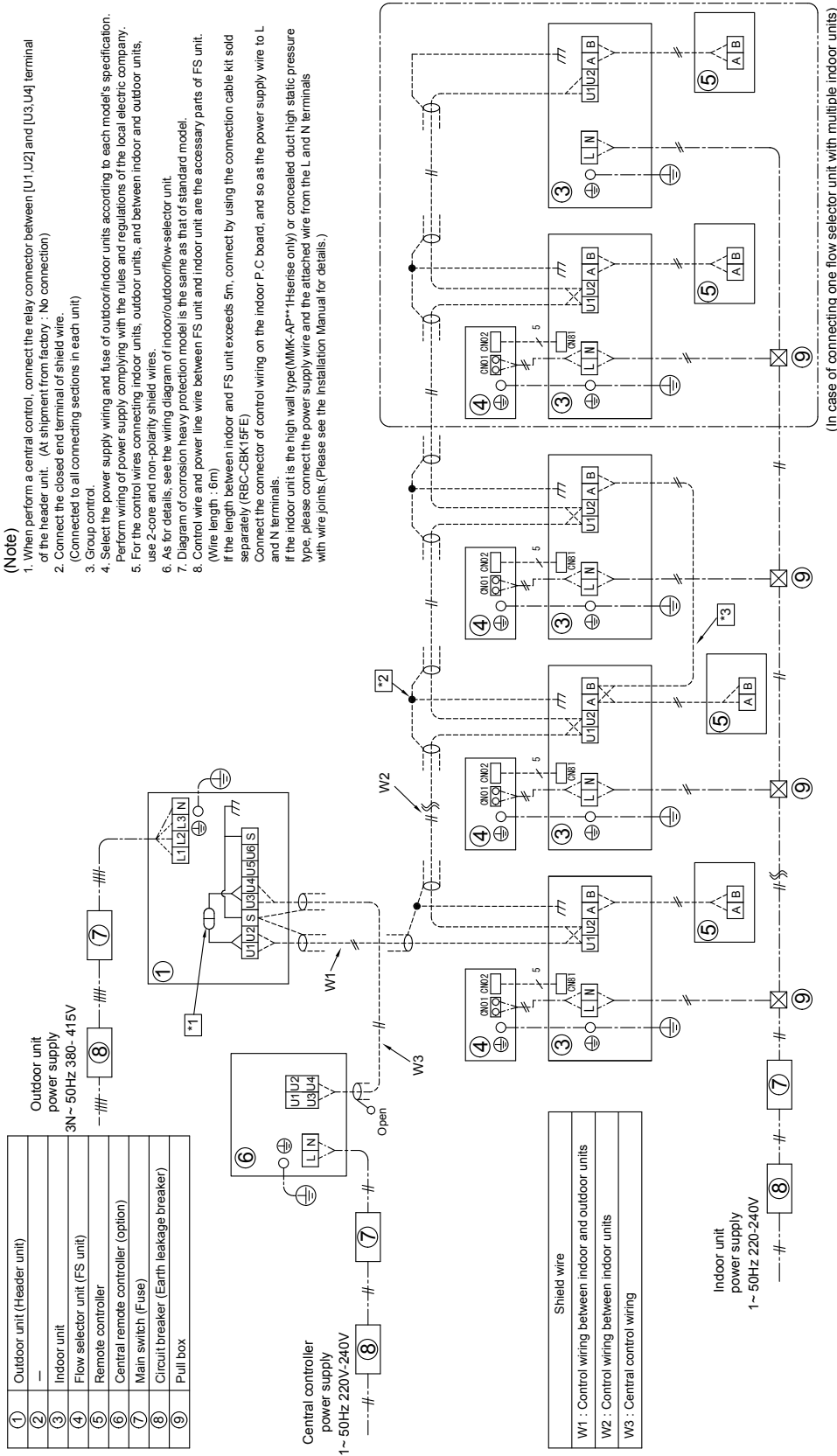
5-7. Connecting Diagrams

Single Unit connected

Model : MMY-MAP0806FT8P-E, MMY-MAP1006FT8P-E, MMY-MAP1206FT8P-E, MMY-MAP1406FT8P-E
 MMY-MAP1606FT8P-E, MMY-MAP1806FT8P-E, MMY-MAP2006FT8P-E

(Note)

1. When perform a central control, connect the relay connector between [U1,U2] and [U3,U4] terminal of the header unit. (At shipment from factory, No connection)
2. Connect the closed end terminal of shield wire.
3. Group control.
(Connected to all connecting sections in each unit)
4. Select the power supply wiring and fuse of outdoor/indoor units according to each model's specification. Perform wiring of power supply complying with the rules and regulations of the local electric company.
5. For the control wires connecting indoor units, outdoor units, and between indoor and outdoor units, use 2-core and non-polarity shield wires.
6. As for details, see the wiring diagram of indoor/outdoor/flow-selector unit.
7. Diagram of corrosion heavy protection model is the same as that of standard model.
8. Control wire and power line wire between FS unit and indoor unit are the accessory parts of FS unit. (Wire length : 5m)
If the length between indoor and FS unit exceeds 5m, connect by using the connection cable kit sold separately (RBC-CBK15FE)
9. Connect the connector of control wiring on the indoor P.C board, and so as the power supply wire to L and N terminals.
If the indoor unit is the high wall type (MMK-AP**H-series only) or concealed duct high static pressure type, please connect the power supply wire and the attached wire from the L and N terminals with wire joints. (Please see the Installation Manual for details.)



<Connecting with Single port type FS unit> (1/3)
 (In case of connecting one flow selector unit with multiple indoor units)

①	Outdoor unit (Header unit)
②	—
③	Indoor unit
④	Flow selector unit (FS unit)
⑤	Remote controller
⑥	Central remote controller (option)
⑦	Main switch (Fuse)
⑧	Circuit breaker (Earth leakage breaker)
⑨	Pull box

①	Central controller power supply 1~ 50Hz 220V-240V
②	Outdoor unit power supply 3N~ 50Hz 380-415V
③	Indoor unit power supply 1~ 50Hz 220-240V

W1	Control wiring between indoor and outdoor units
W2	Control wiring between indoor units
W3	Central control wiring

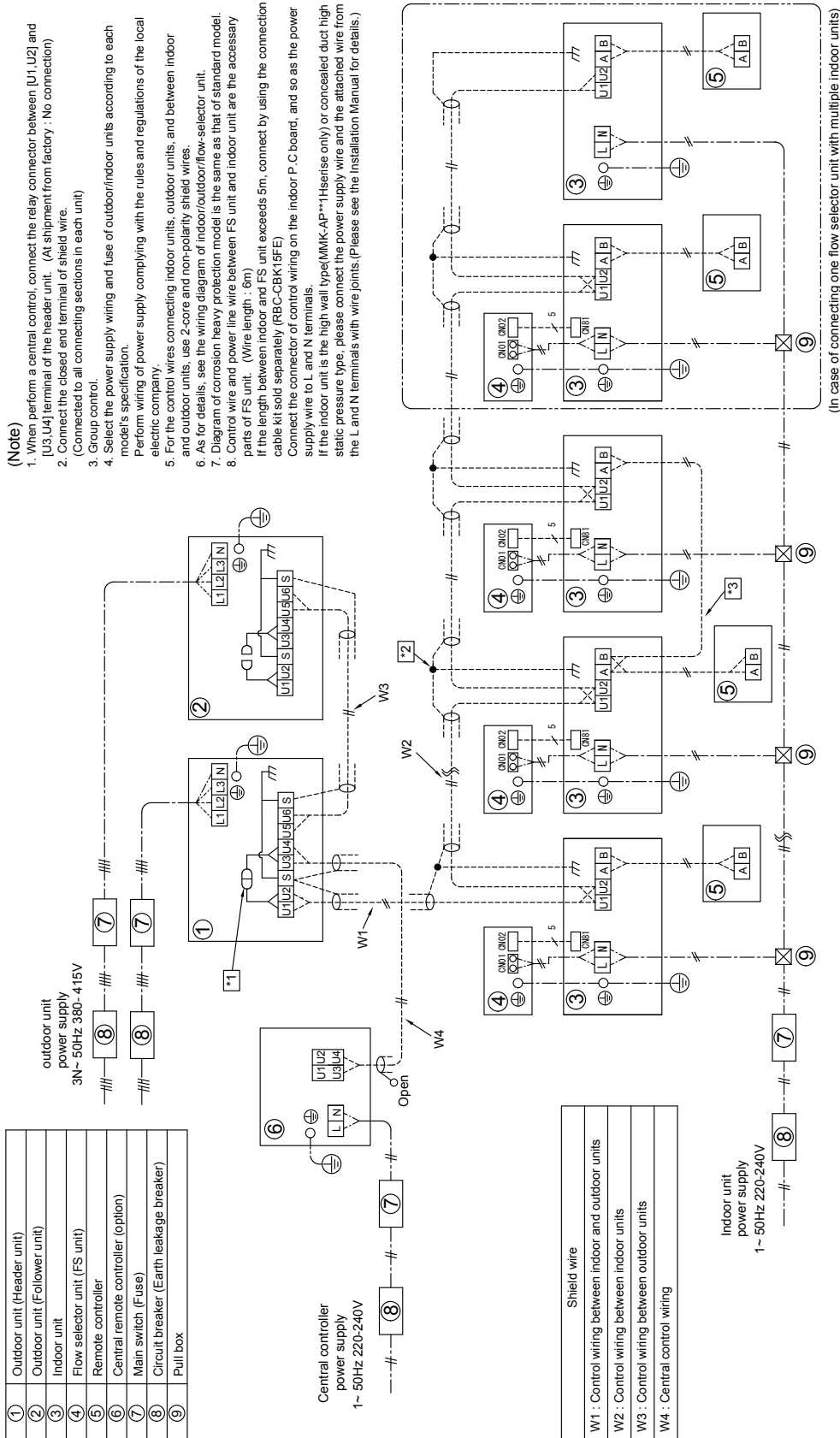
Shield wire
Indoor unit power supply 1~ 50Hz 220-240V

Two Units connected

Model : MMY-AP2216FT8P-E, MMY-AP2416FT8P-E, MMY-AP2616FT8P-E, MMY-AP2816FT8P-E, MMY-AP3016FT8P-E, MMY-AP3216FT8P-E, MMY-AP3416FT8P-E, MMY-AP3616FT8P-E, MMY-AP3816FT8P-E, MMY-AP4016FT8P-E

(Note)

1. When perform a central control, connect the relay connector between [U1, U2] and [U3, U4] terminal of the header unit. (At shipment from factory : No connection)
2. Connect the closed end terminal of shield wire.
3. Group control.
4. Select the power supply wiring and fuse of outdoor/indoor units according to each model's specification.
5. Perform wiring of power supply complying with the rules and regulations of the local electric company.
6. For the control wires connecting indoor units, outdoor units, and between indoor and outdoor units, use 2-core and non-polarity shield wires.
7. As for details, see the wiring diagram of indoor/outdoor/flow-selector unit.
8. Diagram of corrosion heavy protection model is the same as that of standard model.
9. Control wire and power line wire between FS unit and indoor unit are the accessory parts of FS unit. (Wire length : 6m)
10. If the length between indoor and FS unit exceeds 5m, connect by using the connection cable kit sold separately (RBC-CBK15FE)



<Connecting with Single port type FS unit> (2/3)

(In case of connecting one flow selector unit with multiple indoor units)

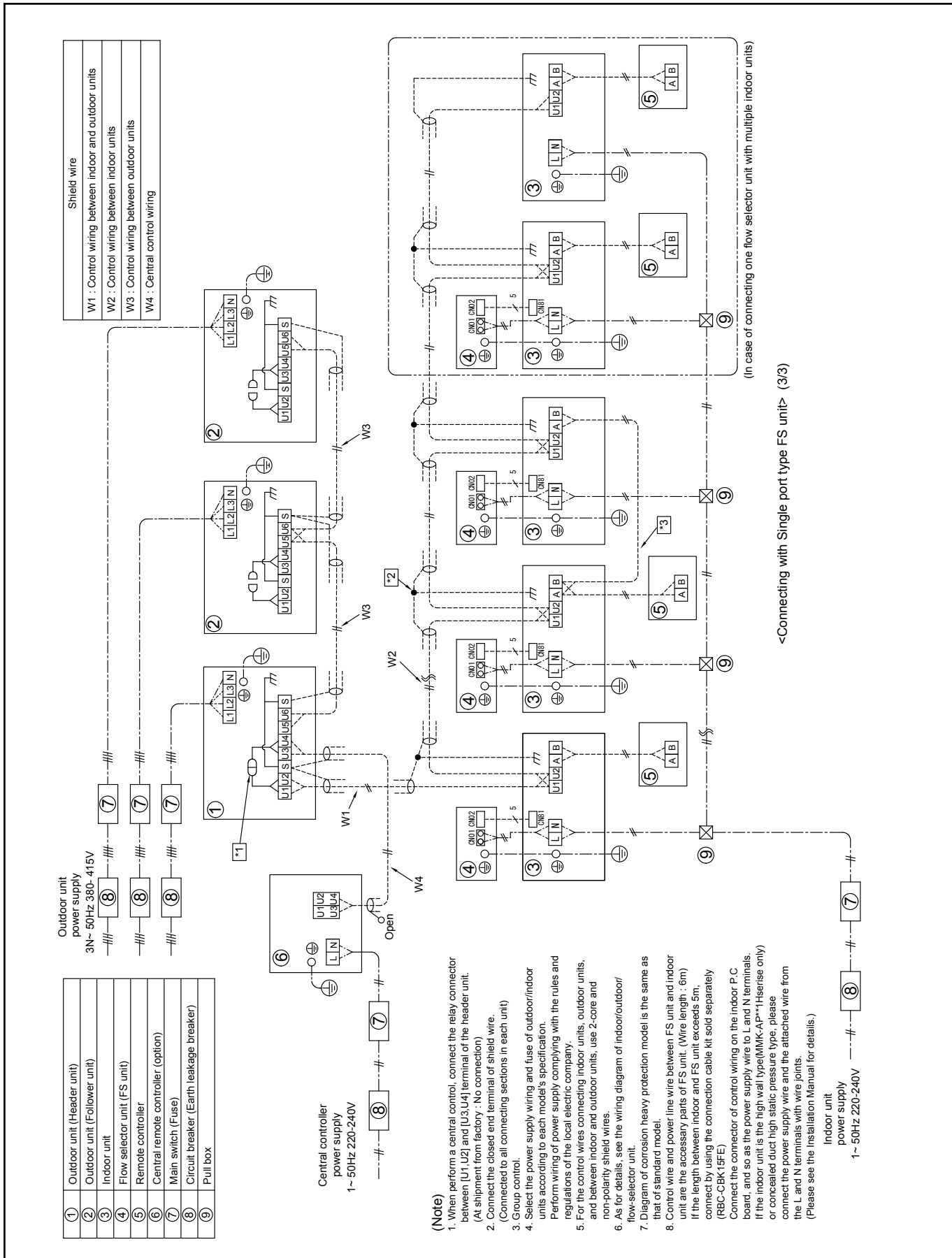
①	Outdoor unit (Header unit)
②	Outdoor unit (Follower unit)
③	Indoor unit
④	Flow selector unit (FS unit)
⑤	Remote controller
⑥	Central remote controller (option)
⑦	Main switch (Fuse)
⑧	Circuit breaker (Earth leakage breaker)
⑨	Pull box

Shield wire	
W1	: Control wiring between indoor and outdoor units
W2	: Control wiring between indoor units
W3	: Control wiring between outdoor units
W4	: Central control wiring



Three Units connected

Model : MMY-AP4216FT8P-E



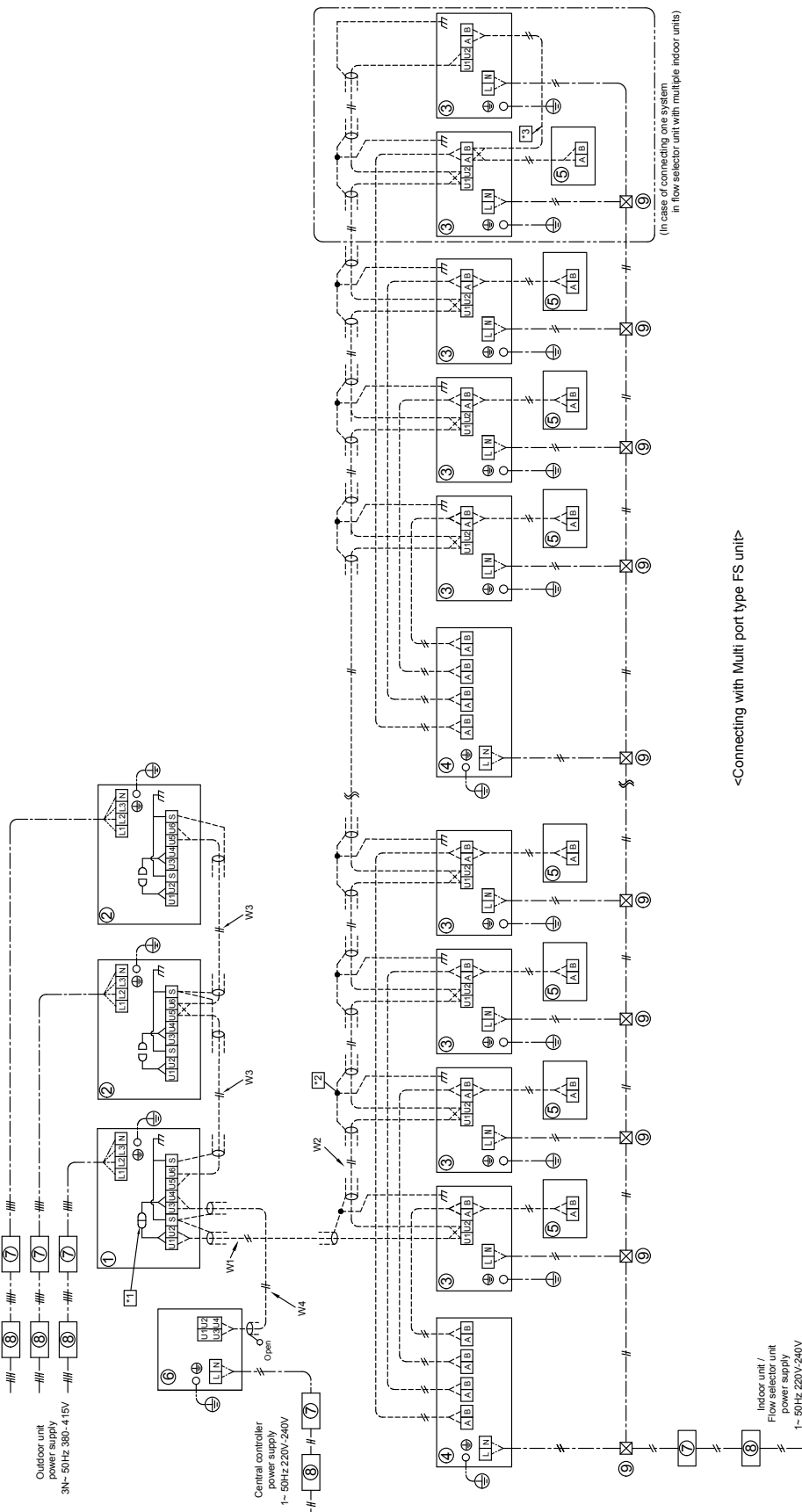
Three Units connected

Model : MMY-AP4416FT8P-E, MMY-AP4616FT8P-E, MMY-AP4616FT8P-E, MMY-AP4816FT8P-E, MMY-AP5016FT8P-E, MMY-AP5216FT8P-E, MMY-AP5416FT8P-E

- (Note)**
- When perform a central control, connect the relay connector between [U1,U2] and [U3,U4] terminal of the header unit. (At shipment from factory: No connection)
 - Connect the closed end terminal of shield wire. (Connected to all connecting sections in each unit)
 - Group control.
 - Select the power supply wiring and fuse of outdoor/indoor units according to each model's specification. Perform wiring of power supply complying with the rules and regulations of the local electric company.
 - For the control wires connecting indoor units, outdoor units, and between indoor and outdoor units, use 2-core and non-polarity shield wires.
 - As for details, see the wiring diagram of indoor/outdoor/flow-selector unit.
 - Diagram of corrosion heavy protection model is the same as that of standard model.

Shield wire	
W1 :	Control wiring between indoor and outdoor units
W2 :	Control wiring between indoor units
W3 :	Control wiring between outdoor units
W4 :	Central control wiring

①	Outdoor unit (Header unit)
②	Outdoor unit (Follower unit)
③	Indoor unit
④	Flow selector unit (FS unit)
⑤	Remote controller
⑥	Central remote controller (option)
⑦	Main switch (Fuse)
⑧	Circuit breaker (Earth leakage breaker)
⑨	Pull box



<Connecting with Multi port type FS unit>

5-8. Applied control for Outdoor Unit

The outdoor fan high static pressure support and priority operation mode setting (cooling / heating / number of units / or priority indoor unit) functions are made available by setting relevant switches provided on the interface P.C. board of the outdoor unit.

5-8-1. Outdoor Fan High Static Pressure Shift

Purpose/characteristics

This function is used when connecting a duct to the discharge port of an outdoor unit (as part of, for example, unit installation on the floor by floor installation.)

Setup

Turn ON the DIP switch [SW10, Bit 2] provided on the interface P.C. board of the outdoor unit.

This function must be enabled with every discharge duct connected outdoor unit for both of the header and follower units.

Specification

Increase the speed of the propeller fan units on the outdoor fan to allow the installation of a duct with a maximum external static pressure not greater than specified in the table below. If a discharge duct with a resistance greater than 15 Pa (1.5 mmAq) is to be used, enable this function. The maximum external static pressures of base units are shown below (Table 1). In the case of combined use of multiple outdoor units, set all the units to the same maximum external static pressure as the one with the lowest maximum external static pressure (see Table 2).

Table 1: Maximum External Static Pressure of Base Outdoor Units



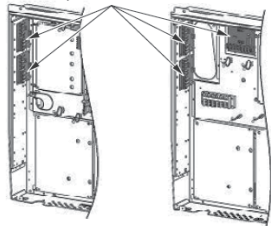
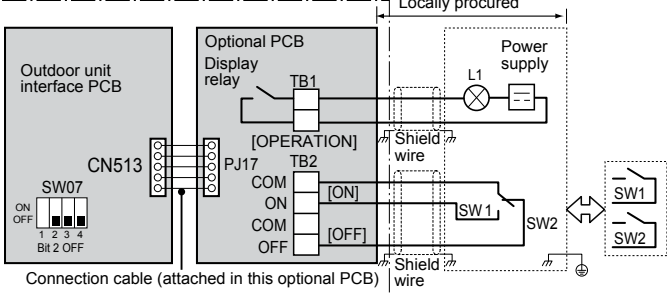
Model	MMY-	MAP0806*	MAP1006*	MAP1206*	MAP1406*	MAP1606*	MAP1806*	MAP2006*
Maximum external static pressure	Pa	60	50	50	40	40	40	40
(*) Outdoor unit air flow	m3/h	9700	9700	12200	12200	17300	17300	17900


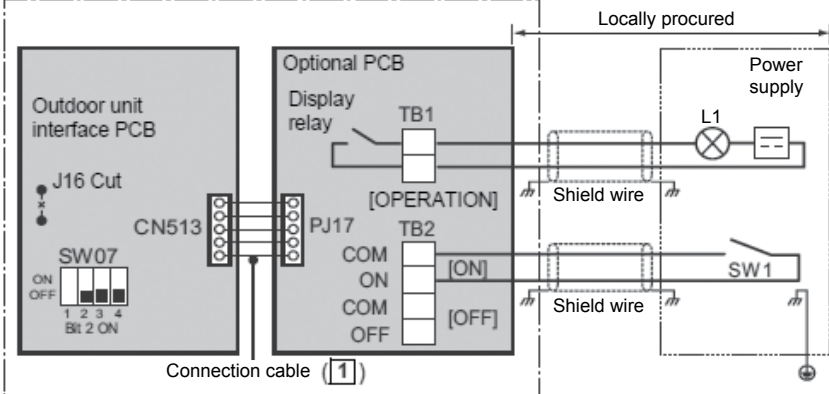

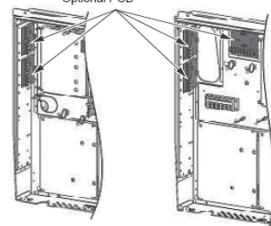
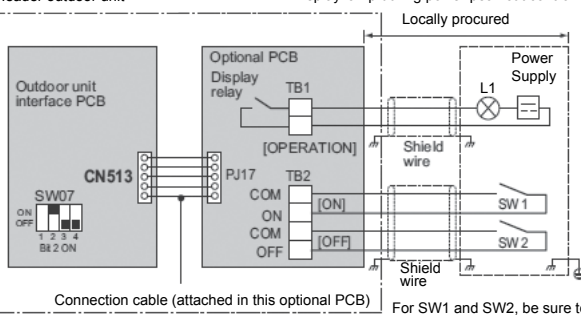
Table 2: Maximum External Static Pressure for Combined Use of Base Units

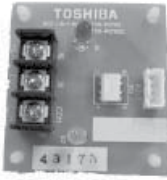

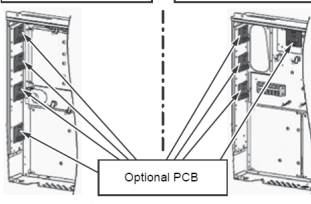
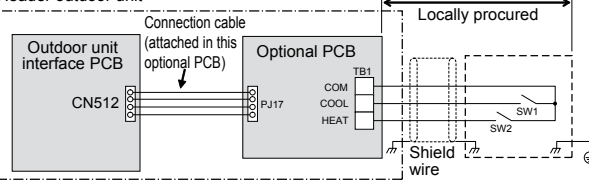
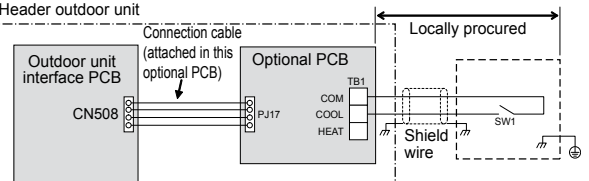
Standard models



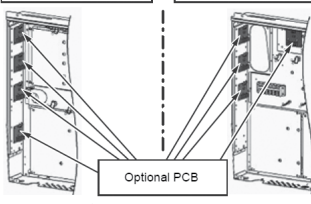
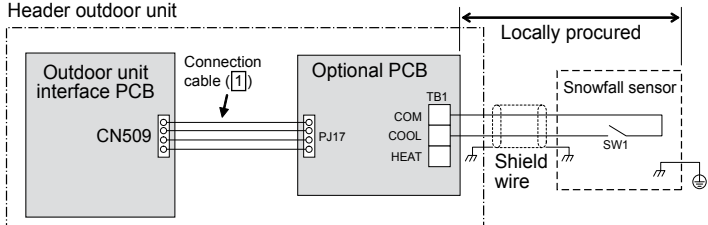
System	Combination			Maximum external static pressure
	HP			
HP	HP			Pa
8	8			60
10	10			50
12	12			50
14	14			40
16	16			40
18	18			40
20	20			40
22	12	10		50
24	14	10		40
26	14	12		40
28	14	14		40
30	16	14		40
32	16	16		40
34	18	16		40
36	18	18		40
38	20	18		40
40	20	20		40
42	14	14	14	40
44	16	14	14	40
46	18	14	14	40
48	16	16	16	40
50	18	16	16	40
52	18	18	16	40

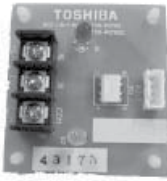

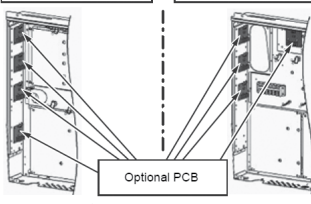
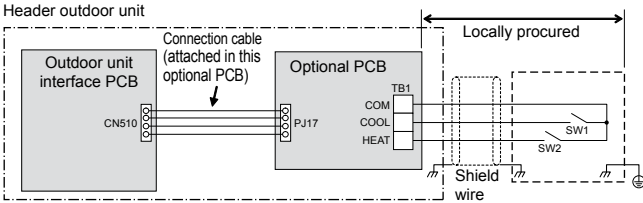
5-9. Optional printed board (PCB) of outdoor unit

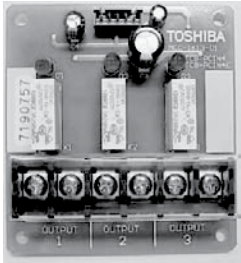
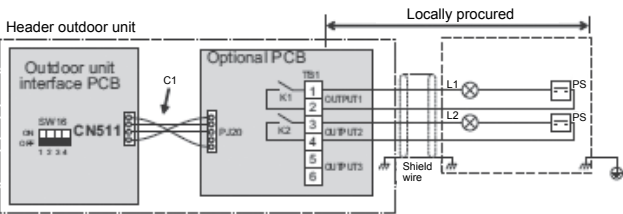

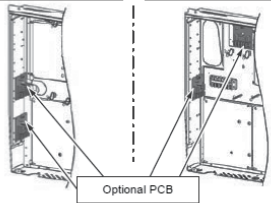
Model name	Appearance	Function																		
TCB-PCDM4E	 <p>Size: 71 x 85 (mm)</p>	<p>[1] Power peak-cut Control</p> <ul style="list-style-type: none"> • Purpose: Limiting air conditioning performance with external signals and decreasing the peak power consumption. • Feature The upper limit capacity of the outdoor unit is restricted based on the outdoor power peak selected setting. <p><u>Standard Specifications</u> (Wiring example)</p>																		
	<p>Application</p>  <p>MMY-MAP080 to 100 MMY-MAP120 to 200</p>  <p>(max. number installed: 1 pc)</p> <p>* Install the optional PCB in the outdoor header unit.</p>	 <p>Header outdoor unit L1: Display lamp during power peak cut control</p> <p>Locally procured</p> <p>For SW1 and SW2, be sure to provide no-voltage contacts for each terminal. The input signals of SW1 and SW2 may be pulse input (100 msec or more) or continuous make. Do not turn on [SW1] and [SW2] simultaneously.</p> <p><SW07 (bit 2) OFF [2-stage switching]></p> <table border="1" data-bbox="550 1164 1468 1366"> <thead> <tr> <th colspan="2">Input</th> <th colspan="2">SW07 (bit 1)</th> <th rowspan="2">Display relay (L1)</th> </tr> <tr> <th>SW1</th> <th>SW2</th> <th>Bit 1 OFF</th> <th>Bit 1 ON</th> </tr> </thead> <tbody> <tr> <td>OFF</td> <td>ON</td> <td>100 % (normal operation)</td> <td>100 % (normal operation)</td> <td>OFF</td> </tr> <tr> <td>ON</td> <td>OFF</td> <td>0 % (forced stop)</td> <td>Approx. 60 % (upper limit regulated)</td> <td>ON</td> </tr> </tbody> </table>	Input		SW07 (bit 1)		Display relay (L1)	SW1	SW2	Bit 1 OFF	Bit 1 ON	OFF	ON	100 % (normal operation)	100 % (normal operation)	OFF	ON	OFF	0 % (forced stop)	Approx. 60 % (upper limit regulated)
Input		SW07 (bit 1)		Display relay (L1)																
SW1	SW2	Bit 1 OFF	Bit 1 ON																	
OFF	ON	100 % (normal operation)	100 % (normal operation)	OFF																
ON	OFF	0 % (forced stop)	Approx. 60 % (upper limit regulated)	ON																

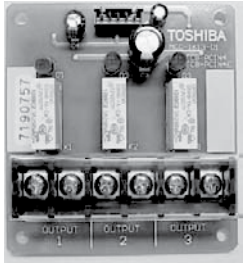
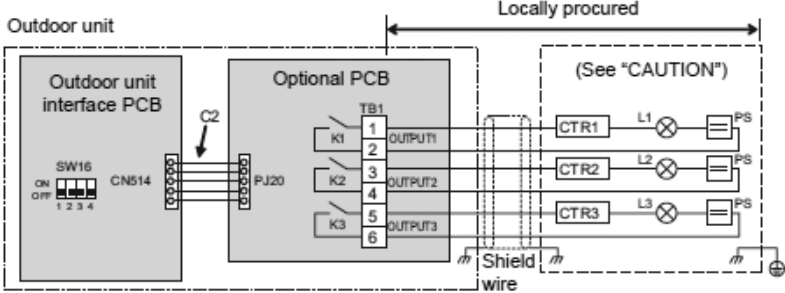

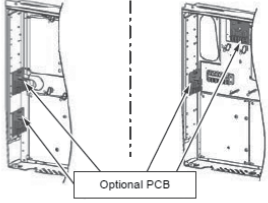
Model name	Appearance	Function																												
TCB-PCMO4E	 <p>Size: 55.5 x 60 (mm)</p>	<p>For one input function</p> <p>Power peak-cut ON-OFF control is made possible on only the [ON] terminal input (SW1) by cutting the jumper lead (J16) of the center outdoor unit interface PCB.</p> <p>(Wiring example)</p>																												
	<p>Application</p>	<p>Header outdoor unit</p> <p>L1: Display lamp during power peak cut control</p>  <p>Locally procured</p> <p>Power supply</p> <p>Shield wire</p> <p>Shield wire</p> <p>Connection cable (1)</p>																												
		<table border="1"> <thead> <tr> <th rowspan="2">Jumper Lead J16</th> <th rowspan="2">Input SW1</th> <th colspan="2">SW07 (bit 1)</th> <th rowspan="2">Display relay (L1)</th> </tr> <tr> <th>Bit 1 OFF</th> <th>Bit 1 ON</th> </tr> </thead> <tbody> <tr> <td rowspan="2">Cut</td> <td>OFF</td> <td>100% (normal operation)</td> <td>100% (normal operation)</td> <td>OFF</td> </tr> <tr> <td>ON</td> <td>0% (forced stop)</td> <td>Approx. 60% (upper limit regulated)</td> <td>ON</td> </tr> </tbody> </table>	Jumper Lead J16	Input SW1	SW07 (bit 1)		Display relay (L1)	Bit 1 OFF	Bit 1 ON	Cut	OFF	100% (normal operation)	100% (normal operation)	OFF	ON	0% (forced stop)	Approx. 60% (upper limit regulated)	ON												
	Jumper Lead J16	Input SW1			SW07 (bit 1)			Display relay (L1)																						
Bit 1 OFF			Bit 1 ON																											
Cut	OFF	100% (normal operation)	100% (normal operation)	OFF																										
	ON	0% (forced stop)	Approx. 60% (upper limit regulated)	ON																										
<p>MMY-MAP080 to 100 MMY-MAP120 to 200</p> <p>Optional PCB</p>  <p>(max. number installed: 1 pc)</p> <p>* Install the optional PCB in the outdoor header unit.</p>	<p><SW07 (bit 2) OFF [2.stage switching]></p> <p>Power peak-cut control turns ON when SW1 in the wiring example is ON (continuous make)</p> <p>Enhanced Specifications (Wiring example)</p> <p>Header outdoor unit</p> <p>L1: Display lamp during power peak cut control</p>  <p>Locally procured</p> <p>Power Supply</p> <p>Shield wire</p> <p>Shield wire</p> <p>Connection cable (attached in this optional PCB)</p> <p>For SW1 and SW2, be sure to provide no-voltage contacts for each terminal.</p> <p><SW07 (bit 2) ON [4-stage switching]></p> <table border="1"> <thead> <tr> <th colspan="2">Input</th> <th colspan="2">SW07 (bit 1)</th> <th rowspan="2">Display replay (L1)</th> </tr> <tr> <th>SW1</th> <th>SW2</th> <th>Bit 1 OFF</th> <th>Bit 1 ON</th> </tr> </thead> <tbody> <tr> <td>OFF</td> <td>OFF</td> <td>100% (normal operation)</td> <td>100% (normal operation)</td> <td>OFF</td> </tr> <tr> <td>ON</td> <td>OFF</td> <td>Approx. 80% (Upper limit regulated)</td> <td>Approx. 85% (upper limit regulated)</td> <td>ON</td> </tr> <tr> <td>OFF</td> <td>ON</td> <td>Approx. 60% (Upper Limit regulated)</td> <td>Approx. 75% (Upper Limit regulated)</td> <td>ON</td> </tr> <tr> <td></td> <td>ON</td> <td>0% (forced stop)</td> <td>Approx. 60% (upper Limit regulated)</td> <td>ON</td> </tr> </tbody> </table>	Input		SW07 (bit 1)		Display replay (L1)	SW1	SW2	Bit 1 OFF	Bit 1 ON	OFF	OFF	100% (normal operation)	100% (normal operation)	OFF	ON	OFF	Approx. 80% (Upper limit regulated)	Approx. 85% (upper limit regulated)	ON	OFF	ON	Approx. 60% (Upper Limit regulated)	Approx. 75% (Upper Limit regulated)	ON		ON	0% (forced stop)	Approx. 60% (upper Limit regulated)	ON
Input		SW07 (bit 1)		Display replay (L1)																										
SW1	SW2	Bit 1 OFF	Bit 1 ON																											
OFF	OFF	100% (normal operation)	100% (normal operation)	OFF																										
ON	OFF	Approx. 80% (Upper limit regulated)	Approx. 85% (upper limit regulated)	ON																										
OFF	ON	Approx. 60% (Upper Limit regulated)	Approx. 75% (Upper Limit regulated)	ON																										
	ON	0% (forced stop)	Approx. 60% (upper Limit regulated)	ON																										

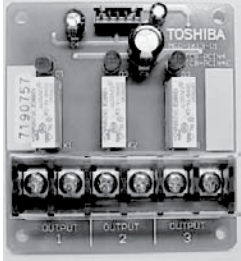

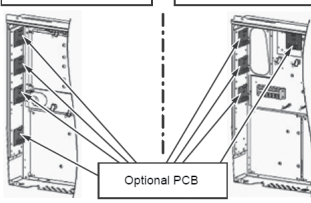
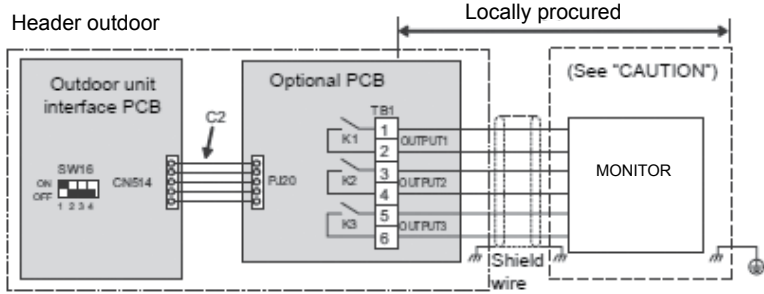
Model name	Appearance	Function																
TCB-PCMO4E	 <p>Size: 55.5 x 60 (mm)</p>	<p>[2] External master ON/OFF control</p> <ul style="list-style-type: none"> • Feature The outdoor unit starts or stop the system. • Function By connecting the cable (attached in this optional PCB) to the interface PC board on an outdoor unit, all indoor units connected to the outdoor unit enable to operate simultaneously. • Operation The outdoor unit connection is for the header unit (U1). 																
	<p>Application</p>  <p>MMY-MAP080 to 100 MMY-MAP120 to 200</p>  <p>(max. number installed: 4 pcs)</p> <p>* Install the optional PCB in the outdoor header unit.</p>	<p>Header outdoor unit</p>  <p>SW1: Operation input switch SW2: Stop input switch</p> <table border="1" data-bbox="550 891 1465 1064"> <thead> <tr> <th>Terminal</th> <th>Input signal</th> <th>Operation</th> </tr> </thead> <tbody> <tr> <td>COOL (SW1)</td> <td>ON OFF</td> <td>All indoor units operate together</td> </tr> <tr> <td>HEAT (SW2)</td> <td>ON OFF</td> <td>All indoor units stop together</td> </tr> </tbody> </table> <p>Provide no-voltage pulse contacts for each terminal. Hold the ON state for at least 100 msec. Do not turn SW1 and SW2 ON simultaneously</p> <p>[3] Night time operation (sound reduction) control</p> <ul style="list-style-type: none"> • Purpose: Reducing noise from an outdoor unit • Feature Sound level can be reduced by restricting the compressor and fan speed • Function As the cable (attached in this optional PCB) is connected to the "Interface PCB" on an outdoor unit, both compressor speed and fan speed are restricted while the signal of the night operation control is input. It makes the noise reduction during the night time operation. • Operation The outdoor unit connection is for the header unit (U1). <p>Header outdoor unit</p>  <p>SW1: Night time signal switch</p> <table border="1" data-bbox="550 1792 1465 1964"> <thead> <tr> <th>Terminal</th> <th>Input signal</th> <th>Operation</th> </tr> </thead> <tbody> <tr> <td rowspan="2">COOL (SW1)</td> <td>ON OFF</td> <td>All indoor units operate together</td> </tr> <tr> <td>ON OFF</td> <td>All indoor units stop together</td> </tr> </tbody> </table> <p>Each terminal should be connected to dry contact. The input signal is recognized during its rising/falling phase. (After reaching the top/bottom of the rising/falling edge, the signal must remain there for at least 100 ms.)</p>	Terminal	Input signal	Operation	COOL (SW1)	ON OFF	All indoor units operate together	HEAT (SW2)	ON OFF	All indoor units stop together	Terminal	Input signal	Operation	COOL (SW1)	ON OFF	All indoor units operate together	ON OFF
Terminal	Input signal	Operation																
COOL (SW1)	ON OFF	All indoor units operate together																
HEAT (SW2)	ON OFF	All indoor units stop together																
Terminal	Input signal	Operation																
COOL (SW1)	ON OFF	All indoor units operate together																
	ON OFF	All indoor units stop together																

Model name	Appearance	Function																																		
TCB-PCMO4E	 <p>Size: 55.5 x 60 (mm)</p>	<p>Sound reduction and approximation capacity (reference)</p> <table border="1" data-bbox="550 367 1362 649"> <thead> <tr> <th rowspan="2"></th> <th rowspan="2">Night operation sound reduction dB(A)</th> <th colspan="2">Capacity</th> </tr> <tr> <th>COOL</th> <th>HEAT</th> </tr> </thead> <tbody> <tr> <td>0806 type</td> <td>50</td> <td>Approx.85%</td> <td>Approx.85%</td> </tr> <tr> <td>1006 type</td> <td>50</td> <td>Approx.70%</td> <td>Approx.70%</td> </tr> <tr> <td>1206 type</td> <td>53</td> <td>Approx.80%</td> <td>Approx.80%</td> </tr> <tr> <td>1406 type</td> <td>53</td> <td>Approx.70%</td> <td>Approx.70%</td> </tr> <tr> <td>1606 type</td> <td>54</td> <td>Approx.65%</td> <td>Approx.65%</td> </tr> <tr> <td>1806 type</td> <td>54</td> <td>Approx.60%</td> <td>Approx.60%</td> </tr> <tr> <td>2006 type</td> <td>54</td> <td>Approx.55%</td> <td>Approx.55%</td> </tr> </tbody> </table>		Night operation sound reduction dB(A)	Capacity		COOL	HEAT	0806 type	50	Approx.85%	Approx.85%	1006 type	50	Approx.70%	Approx.70%	1206 type	53	Approx.80%	Approx.80%	1406 type	53	Approx.70%	Approx.70%	1606 type	54	Approx.65%	Approx.65%	1806 type	54	Approx.60%	Approx.60%	2006 type	54	Approx.55%	Approx.55%
		Night operation sound reduction dB(A)			Capacity																															
			COOL	HEAT																																
	0806 type	50	Approx.85%	Approx.85%																																
1006 type	50	Approx.70%	Approx.70%																																	
1206 type	53	Approx.80%	Approx.80%																																	
1406 type	53	Approx.70%	Approx.70%																																	
1606 type	54	Approx.65%	Approx.65%																																	
1806 type	54	Approx.60%	Approx.60%																																	
2006 type	54	Approx.55%	Approx.55%																																	
<p>Application</p>  <p>MMY-MAP080 to 100 MMY-MAP120 to 200</p>  <p>(max. number installed: 4 pcs)</p> <p>* Install the optional PCB in the outdoor header unit.</p>	<p>Condition Cooling: (Indoor 27 deg DB, 19 deg WB) (Outdoor temperature 25 deg DB) Heating: (Indoor 20 deg DB) (Outdoor temperature 7 deg DB, 6 deg WB)</p> <p>[4] Snowfall fan control</p> <ul style="list-style-type: none"> • Purpose: Rotating the fan to prevent snow accumulation • Feature <p>Outdoor fan is operated from the snowfall signal received from the outside.</p> <p>▼ Functions The outdoor unit fan operates at snowfall by connecting to the outdoor unit interface PCB.</p> <p>▼ Operation</p>  <p>SW1: Snowfall selection switch (snowfall sensor)</p> <table border="1" data-bbox="545 1413 1465 1585"> <thead> <tr> <th>Terminal</th> <th>Input signal</th> <th>Operation</th> </tr> </thead> <tbody> <tr> <td rowspan="4">Cooling (SW1)</td> <td>ON</td> <td rowspan="2"> </td> <td rowspan="2">Snowfall fan control (Fan in outdoor unit operates.)</td> </tr> <tr> <td>OFF</td> </tr> <tr> <td>ON</td> <td rowspan="2"> </td> <td rowspan="2">Normal operation</td> </tr> <tr> <td>OFF</td> </tr> </tbody> </table> <p>Be sure to provide no-voltage continuous contacts for each terminal.</p>	Terminal	Input signal	Operation	Cooling (SW1)	ON		Snowfall fan control (Fan in outdoor unit operates.)	OFF	ON		Normal operation	OFF																							
Terminal	Input signal	Operation																																		
Cooling (SW1)	ON		Snowfall fan control (Fan in outdoor unit operates.)																																	
	OFF																																			
	ON		Normal operation																																	
	OFF																																			

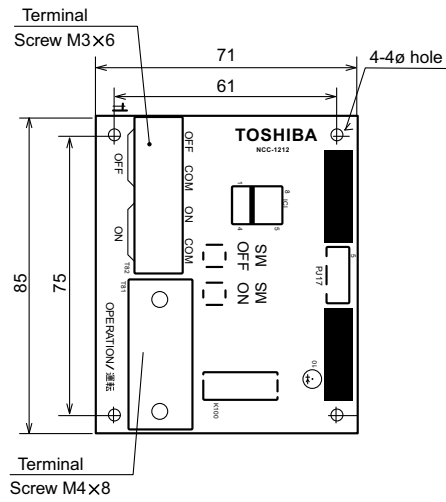
Model name	Appearance	Function																																																							
TCB-PCIN4E	 <p>Size: 55.5 x 60 (mm)</p>	<p>[5] Operation mode selection control</p> <ul style="list-style-type: none"> • Purpose: Limiting operation modes to cooling and heating only • Feature This control can restrict the selectable operation mode. <p>▼ Functions The heating/cooling mode of the system can be selected by connecting to the interface PCB of outdoor units.</p> <p>▼ Operation The outdoor unit connection is for the header unit (U1).</p>																																																							
	<p>Application</p>  <p>MMY-MAP080 to 100 MMY-MAP120 to 200</p>  <p>(max. number installed: 4 pcs)</p> <p>* Install the optional PCB in the outdoor header unit.</p>	 <p>SW1: Cooling mode specified input switch SW2: Heating mode specified input switch</p> <table border="1" data-bbox="558 896 1189 1019"> <thead> <tr> <th colspan="2">Input Signal</th> <th rowspan="2">Operation: Selected operation mode</th> </tr> <tr> <th>Cooling (SW1)</th> <th>Heating (SW2)</th> </tr> </thead> <tbody> <tr> <td>ON</td> <td>OFF</td> <td>Cooling operation only</td> </tr> <tr> <td>OFF</td> <td>ON</td> <td>Heating operation only</td> </tr> <tr> <td>OFF</td> <td>OFF</td> <td>Normal operation</td> </tr> </tbody> </table> <p>Each terminal should be connected to dry contact.</p> <p>About Switching of Processing of Indoor Unit Operation State</p> <p>Processing of the operation state can be switched for indoor units in a mode other than the selected operation mode by setting the jumper lead (J01) of the header outdoor unit interface PCB.</p> <table border="1" data-bbox="558 1265 1276 1792"> <thead> <tr> <th>Jumper lead</th> <th colspan="3">Details of Processing</th> </tr> </thead> <tbody> <tr> <td rowspan="4">J01 connected (factory default)</td> <td colspan="3">Unallowed indoor units in a mode other than the selected operation mode are not treated as priority (thermo OFF state). (Unallowed indoor units)</td> </tr> <tr> <td>Operation Mode</td> <td>Operation State</td> <td>Remote control</td> </tr> <tr> <td>Cooling unit</td> <td>Air blow operation at blow rate set on remote control</td> <td rowspan="3">⏻, ⏪ indicator is displayed.</td> </tr> <tr> <td>Heating unit</td> <td>Air blow operation at super-slow blow rate</td> </tr> <tr> <td>Air blow unit</td> <td>Regular air blow operation at blow rate set on remote control</td> </tr> <tr> <td rowspan="4">J01 cut</td> <td colspan="3">Indoor units in a mode other than the selected operation mode are forcibly switched to the selected operation mode.</td> </tr> <tr> <td>PC board selection mode</td> <td colspan="2">Remote control operation/display</td> </tr> <tr> <td>Normal</td> <td>*, ◊, ✨, or ❄️ can be selected</td> <td rowspan="3">When using the remote control, ⏻ (mode select control) indicator is displayed.</td> </tr> <tr> <td>Cool</td> <td>Only *, ◊, or ❄️ can be selected</td> </tr> <tr> <td>Heat</td> <td>Only ✨ or ❄️ can be selected</td> </tr> </tbody> </table> <p>The jumper lead is not switched. Indoor units in a mode other than the selected operation mode are forcibly switched to the selected operation mode.</p> <table border="1" data-bbox="558 1971 1260 2116"> <thead> <tr> <th>PC board selection mode</th> <th colspan="2">Remote control operation/display</th> </tr> </thead> <tbody> <tr> <td>Normal</td> <td>*, ◊, ✨, or ❄️ can be selected</td> <td rowspan="3">When using the remote control, ⏻ (mode select control) indicator is displayed.</td> </tr> <tr> <td>Cool</td> <td>Only *, ◊, or ❄️ can be selected</td> </tr> <tr> <td>Heat</td> <td>Only ✨ or ❄️ can be selected</td> </tr> </tbody> </table>	Input Signal		Operation: Selected operation mode	Cooling (SW1)	Heating (SW2)	ON	OFF	Cooling operation only	OFF	ON	Heating operation only	OFF	OFF	Normal operation	Jumper lead	Details of Processing			J01 connected (factory default)	Unallowed indoor units in a mode other than the selected operation mode are not treated as priority (thermo OFF state). (Unallowed indoor units)			Operation Mode	Operation State	Remote control	Cooling unit	Air blow operation at blow rate set on remote control	⏻, ⏪ indicator is displayed.	Heating unit	Air blow operation at super-slow blow rate	Air blow unit	Regular air blow operation at blow rate set on remote control	J01 cut	Indoor units in a mode other than the selected operation mode are forcibly switched to the selected operation mode.			PC board selection mode	Remote control operation/display		Normal	*, ◊, ✨, or ❄️ can be selected	When using the remote control, ⏻ (mode select control) indicator is displayed.	Cool	Only *, ◊, or ❄️ can be selected	Heat	Only ✨ or ❄️ can be selected	PC board selection mode	Remote control operation/display		Normal	*, ◊, ✨, or ❄️ can be selected	When using the remote control, ⏻ (mode select control) indicator is displayed.	Cool	Only *, ◊, or ❄️ can be selected	Heat
Input Signal		Operation: Selected operation mode																																																							
Cooling (SW1)	Heating (SW2)																																																								
ON	OFF	Cooling operation only																																																							
OFF	ON	Heating operation only																																																							
OFF	OFF	Normal operation																																																							
Jumper lead	Details of Processing																																																								
J01 connected (factory default)	Unallowed indoor units in a mode other than the selected operation mode are not treated as priority (thermo OFF state). (Unallowed indoor units)																																																								
	Operation Mode	Operation State	Remote control																																																						
	Cooling unit	Air blow operation at blow rate set on remote control	⏻, ⏪ indicator is displayed.																																																						
	Heating unit	Air blow operation at super-slow blow rate																																																							
Air blow unit	Regular air blow operation at blow rate set on remote control																																																								
J01 cut	Indoor units in a mode other than the selected operation mode are forcibly switched to the selected operation mode.																																																								
	PC board selection mode	Remote control operation/display																																																							
	Normal	*, ◊, ✨, or ❄️ can be selected	When using the remote control, ⏻ (mode select control) indicator is displayed.																																																						
	Cool	Only *, ◊, or ❄️ can be selected																																																							
Heat	Only ✨ or ❄️ can be selected																																																								
PC board selection mode	Remote control operation/display																																																								
Normal	*, ◊, ✨, or ❄️ can be selected	When using the remote control, ⏻ (mode select control) indicator is displayed.																																																							
Cool	Only *, ◊, or ❄️ can be selected																																																								
Heat	Only ✨ or ❄️ can be selected																																																								

Model name	Appearance	Function																			
TCB-PCIN4E	 <p>Size: 73 x 79 (mm)</p>	<p>[6] Error / Operation Output</p> <ul style="list-style-type: none"> • Feature Operation and error monitoring is possible. <p>▼ Function The operation error output PCB can indicate operation operation and error states by connecting to the interface PCB of outdoor units.</p> <p>▼ Operation Operation output: The operation indicator is on while any indoor unit in the system is operating. Error output : The error indicator is on when an error is occurred on even one of the indoor or outdoor units in the system.</p> <p>Wiring example</p> 																			
	<p>Application</p>  <p>MMY-MAP080 to 100 MMY-MAP120 to 200</p>  <p>Optional PCB (max. number installed: 2 pcs)</p> <p>* Install the optional PCB in the outdoor header unit.</p>	<table border="1"> <tr> <td>C1</td> <td>Attached connection cable 1 (4 wires)</td> </tr> <tr> <td>CN511</td> <td>Connector on interface side (green)</td> </tr> <tr> <td>K1, K2</td> <td>Relays</td> </tr> <tr> <td>L1</td> <td>Error indication Lamp</td> </tr> <tr> <td>L2</td> <td>Operation indication Lamp</td> </tr> <tr> <td>OUTPUT1</td> <td>Error output</td> </tr> <tr> <td>OUTPUT2</td> <td>Operation output</td> </tr> <tr> <td>PJ20</td> <td>Connector on optional PCB side</td> </tr> <tr> <td>PS</td> <td>Power supply unit</td> </tr> <tr> <td>TB1</td> <td>Terminal block</td> </tr> </table> <p>* [OUTPUT3] always output during AC power is connecting.</p>	C1	Attached connection cable 1 (4 wires)	CN511	Connector on interface side (green)	K1, K2	Relays	L1	Error indication Lamp	L2	Operation indication Lamp	OUTPUT1	Error output	OUTPUT2	Operation output	PJ20	Connector on optional PCB side	PS	Power supply unit	TB1
C1	Attached connection cable 1 (4 wires)																				
CN511	Connector on interface side (green)																				
K1, K2	Relays																				
L1	Error indication Lamp																				
L2	Operation indication Lamp																				
OUTPUT1	Error output																				
OUTPUT2	Operation output																				
PJ20	Connector on optional PCB side																				
PS	Power supply unit																				
TB1	Terminal block																				

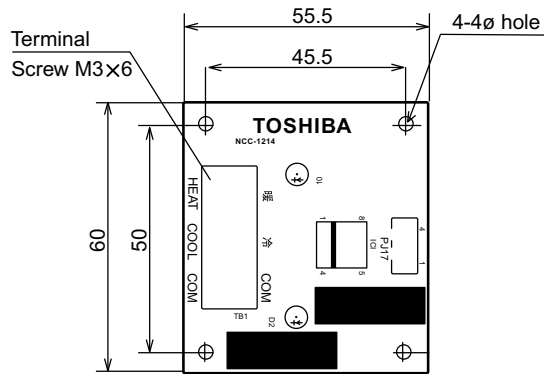
Model name	Appearance	Function																									
TCB-PCIN4E	 <p>Size: 73 x 79 (mm)</p>	<p>[7] Compressor Operation Output</p> <ul style="list-style-type: none"> • Feature Outputs the operation status of the compressors in each outdoor unit. <p>▼ Functions This function can be applied, for example, to the elapsed operation time count of each compressor mounted on an outdoor unit since the compressor in operation signal can be output externally</p> <p>▼ Operations During compressor operation, the relay of the output terminal corresponding to that compressor turns ON (closes) and turns OFF (opens) when compressor operation stops. As shown in the figure, the output terminals are "OUTPUT1", "OUTPUT2" and "OUTPUT3" from the left compressor facing the front of the outdoor unit.</p> <p>Wiring example</p> 																									
	Application																										
	 <p>MMY-MAP080 to 100 MMY-MAP120 to 200</p>  <p style="text-align: center;">Optional PCB (max. number installed: 2 pcs)</p> <p>* Install the optional PCB in individual outdoor unit</p>	<table border="1" data-bbox="608 1122 1369 1559"> <tbody> <tr> <td>C2</td> <td>Connector cable 2 (I2)</td> </tr> <tr> <td>CN514</td> <td>Connector on interface side (green)</td> </tr> <tr> <td>CTR2</td> <td>Elapsed operation counter1</td> </tr> <tr> <td>CTR2</td> <td>Elapsed operation counter2</td> </tr> <tr> <td>CTR3</td> <td>Elapsed operation counter3</td> </tr> <tr> <td>K1, K2, K3</td> <td>Relays</td> </tr> <tr> <td>L1, L2, L3</td> <td>Operation indication LEDs</td> </tr> <tr> <td>OUTPUT1</td> <td>Compressor 1 operation output terminal</td> </tr> <tr> <td>OUTPUT2</td> <td>Compressor 2 operation output terminal</td> </tr> <tr> <td>OUTPUT3</td> <td>Compressor 3 operation output terminal</td> </tr> <tr> <td>PJ20</td> <td>Connector on optional PCB side</td> </tr> <tr> <td>PS</td> <td>Power supply unit</td> </tr> <tr> <td>TB1</td> <td>Terminal block</td> </tr> </tbody> </table>	C2	Connector cable 2 (I2)	CN514	Connector on interface side (green)	CTR2	Elapsed operation counter1	CTR2	Elapsed operation counter2	CTR3	Elapsed operation counter3	K1, K2, K3	Relays	L1, L2, L3	Operation indication LEDs	OUTPUT1	Compressor 1 operation output terminal	OUTPUT2	Compressor 2 operation output terminal	OUTPUT3	Compressor 3 operation output terminal	PJ20	Connector on optional PCB side	PS	Power supply unit	TB1
C2	Connector cable 2 (I2)																										
CN514	Connector on interface side (green)																										
CTR2	Elapsed operation counter1																										
CTR2	Elapsed operation counter2																										
CTR3	Elapsed operation counter3																										
K1, K2, K3	Relays																										
L1, L2, L3	Operation indication LEDs																										
OUTPUT1	Compressor 1 operation output terminal																										
OUTPUT2	Compressor 2 operation output terminal																										
OUTPUT3	Compressor 3 operation output terminal																										
PJ20	Connector on optional PCB side																										
PS	Power supply unit																										
TB1	Terminal block																										

Model name	Appearance	Function																																															
TCB-PCIN4E	 <p>Size: 73 x 79 (mm)</p>	<p>[8] Operating Rate Output</p> <ul style="list-style-type: none"> • Feature <p>Relay turn ON/OFF depending on the running rate of the system.</p> <p>▼ Feature</p> <p>The operation state can be remotely since the system operating rate single can be output externally.</p> <p>▼ Operation</p> <p>As shown in the table each of the output terminals turn ON (relay closes) and OFF (relay opens) according to the system operating rate.</p> <table border="1" data-bbox="560 636 1380 875"> <thead> <tr> <th>Functions</th> <th>SW16</th> <th>OUTPUT1</th> <th>OUTPUT2</th> <th>OUTPUT3</th> <th>Operating rate FA</th> </tr> </thead> <tbody> <tr> <td rowspan="8">System Operating rate output</td> <td>ON</td> <td>OFF</td> <td>OFF</td> <td>OFF</td> <td>FA=0%</td> </tr> <tr> <td>OFF</td> <td>ON</td> <td>OFF</td> <td>OFF</td> <td>0%<FA<20%</td> </tr> <tr> <td>bit 1: ON bit 2 :OFF</td> <td>OFF</td> <td>ON</td> <td>OFF</td> <td>20%≤FA<35%</td> </tr> <tr> <td></td> <td>ON</td> <td>ON</td> <td>OFF</td> <td>35%≤FA ≤50%</td> </tr> <tr> <td></td> <td>OFF</td> <td>OFF</td> <td>ON</td> <td>50% ≤FA<65%</td> </tr> <tr> <td></td> <td>ON</td> <td>OFF</td> <td>ON</td> <td>65% ≤FA<80%</td> </tr> <tr> <td></td> <td>OFF</td> <td>ON</td> <td>ON</td> <td>80% ≤FA<95%</td> </tr> <tr> <td></td> <td>ON</td> <td>ON</td> <td>ON</td> <td>95% ≤FA</td> </tr> </tbody> </table> <p style="text-align: right;">OFF=relay open ON=relay closed</p>	Functions	SW16	OUTPUT1	OUTPUT2	OUTPUT3	Operating rate FA	System Operating rate output	ON	OFF	OFF	OFF	FA=0%	OFF	ON	OFF	OFF	0%<FA<20%	bit 1: ON bit 2 :OFF	OFF	ON	OFF	20%≤FA<35%		ON	ON	OFF	35%≤FA ≤50%		OFF	OFF	ON	50% ≤FA<65%		ON	OFF	ON	65% ≤FA<80%		OFF	ON	ON	80% ≤FA<95%		ON	ON	ON	95% ≤FA
	Functions	SW16	OUTPUT1	OUTPUT2	OUTPUT3	Operating rate FA																																											
System Operating rate output	ON	OFF	OFF	OFF	FA=0%																																												
	OFF	ON	OFF	OFF	0%<FA<20%																																												
	bit 1: ON bit 2 :OFF	OFF	ON	OFF	20%≤FA<35%																																												
		ON	ON	OFF	35%≤FA ≤50%																																												
		OFF	OFF	ON	50% ≤FA<65%																																												
		ON	OFF	ON	65% ≤FA<80%																																												
		OFF	ON	ON	80% ≤FA<95%																																												
		ON	ON	ON	95% ≤FA																																												
<p>Application</p>  <p>MMY-MAP080 to 100 MMY-MAP120 to 200</p>  <p>(max. number installed: 4 pcs)</p> <p>* Install the optional PCB in the outdoor header unit.</p>	<p>Wiring example</p>  <table border="1" data-bbox="587 1249 1198 1523"> <tbody> <tr> <td>C2</td> <td>Connector cable 2 (②)</td> </tr> <tr> <td>CN514</td> <td>Connector on interface side (green)</td> </tr> <tr> <td>K1, K2, K3</td> <td>Relays</td> </tr> <tr> <td>MONITOR</td> <td>Monitoring device</td> </tr> <tr> <td>OUTPUT1</td> <td>Compressor 1 operation output terminal</td> </tr> <tr> <td>OUTPUT2</td> <td>Compressor 2 operation output terminal</td> </tr> <tr> <td>OUTPUT3</td> <td>Compressor 3 operation output terminal</td> </tr> <tr> <td>PJ20</td> <td>Connector on optional PCB side</td> </tr> <tr> <td>PS</td> <td>Power supply unit</td> </tr> <tr> <td>TB1</td> <td>Terminal block</td> </tr> </tbody> </table>	C2	Connector cable 2 (②)	CN514	Connector on interface side (green)	K1, K2, K3	Relays	MONITOR	Monitoring device	OUTPUT1	Compressor 1 operation output terminal	OUTPUT2	Compressor 2 operation output terminal	OUTPUT3	Compressor 3 operation output terminal	PJ20	Connector on optional PCB side	PS	Power supply unit	TB1	Terminal block																												
C2	Connector cable 2 (②)																																																
CN514	Connector on interface side (green)																																																
K1, K2, K3	Relays																																																
MONITOR	Monitoring device																																																
OUTPUT1	Compressor 1 operation output terminal																																																
OUTPUT2	Compressor 2 operation output terminal																																																
OUTPUT3	Compressor 3 operation output terminal																																																
PJ20	Connector on optional PCB side																																																
PS	Power supply unit																																																
TB1	Terminal block																																																

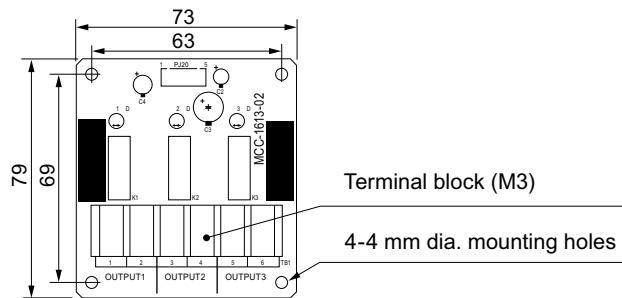
TCB-PCDM4E

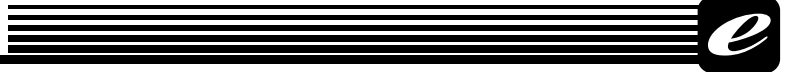


TCB-PCMO4E



TCB-PCIN4E





5-10 Part load performance

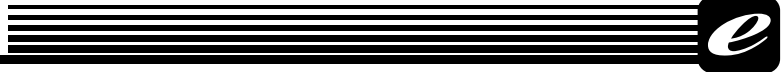
MMY-MAP0806FT8P-E (8HP , 22.4kW system)

Cooling			Compressor + Outdoor Fan Power consumption (kW)															
Outdoor Unit Dry-Bulb (°C)	Outdoor Unit 100% Cooling Capacity (kW)	100% Capacity		90% Capacity		80% Capacity		70% Capacity		60% Capacity		50% Capacity		40% Capacity		30% Capacity		
		TC	PI	TC	PI	TC	PI	TC	PI	TC	PI	TC	PI	TC	PI	TC	PI	
		(kW)	(kW)	(kW)	(kW)	(kW)	(kW)	(kW)	(kW)	(kW)	(kW)	(kW)	(kW)	(kW)	(kW)	(kW)	(kW)	(kW)
40 °C	20.8	20.8	6.43	18.8	4.98	16.7	3.80	14.6	2.88	12.5	2.17	10.4	1.65	8.34	1.30	6.25	1.08	
39 °C	21.2	21.2	6.33	19.1	4.90	16.9	3.75	14.8	2.83	12.7	2.14	10.6	1.63	8.47	1.28	6.35	1.07	
37 °C	21.8	21.8	6.14	19.6	4.76	17.5	3.63	15.3	2.75	13.1	2.07	10.9	1.58	8.73	1.24	6.54	1.03	
35 °C	22.4	22.4	5.95	20.2	4.61	17.9	3.52	15.7	2.66	13.4	2.01	11.2	1.53	8.96	1.20	6.72	1.00	
32 °C	22.4	22.4	5.42	20.2	4.21	17.9	3.23	15.7	2.46	13.4	1.86	11.2	1.43	8.96	1.14	6.72	0.96	
31 °C	22.4	22.4	4.97	20.2	3.87	17.9	2.98	15.7	2.28	13.4	1.74	11.2	1.35	8.96	1.08	6.72	0.92	
30 °C	22.4	22.4	4.77	20.2	3.72	17.9	2.87	15.7	2.19	13.4	1.68	11.2	1.31	8.96	1.05	6.72	0.90	
29 °C	22.4	22.4	4.58	20.2	3.57	17.9	2.76	15.7	2.12	13.4	1.63	11.2	1.27	8.96	1.03	6.72	0.88	
27 °C	22.4	22.4	4.23	20.2	3.31	17.9	2.56	15.7	1.97	13.4	1.52	11.2	1.20	8.96	0.97	6.72	0.84	
25 °C	22.4	22.4	3.91	20.2	3.07	17.9	2.38	15.7	1.84	13.4	1.43	11.2	1.13	8.96	0.93	6.72	0.80	
23 °C	22.4	22.4	3.71	20.2	2.92	17.9	2.27	15.7	1.76	13.4	1.37	11.2	1.09	8.96	0.90	6.72	0.78	
21 °C	22.4	22.4	3.61	20.2	2.84	17.9	2.22	15.7	1.73	13.4	1.35	11.2	1.08	8.96	0.89	6.72	0.78	
20 °C	22.4	22.4	3.56	20.2	2.81	17.9	2.19	15.7	1.71	13.4	1.34	11.2	1.07	8.96	0.89	6.72	0.78	
19 °C	22.4	22.4	3.52	20.2	2.78	17.9	2.17	15.7	1.69	13.4	1.33	11.2	1.07	8.96	0.88	6.72	0.78	
17 °C	22.4	22.4	3.45	20.2	2.72	17.9	2.13	15.7	1.67	13.4	1.31	11.2	1.06	8.96	0.88	6.72	0.77	
15 °C	22.4	22.4	3.38	20.2	2.67	17.9	2.10	15.7	1.65	13.4	1.30	11.2	1.05	8.96	0.88	6.72	0.77	

TC : Total Capacity PI : Power Input
Indoor air temperature conditions : 27.0°C dry-bulb / 19.0°C wet bulb

Heating			Compressor + Outdoor Fan Power consumption (kW)															
Outdoor Unit Dry-Bulb (°C)	Outdoor Unit Wet-Bulb (°C)	Outdoor Unit 100% Heating Capacity (kW)	100% Capacity		90% Capacity		80% Capacity		70% Capacity		60% Capacity		50% Capacity		40% Capacity		30% Capacity	
			TC	PI	TC	PI	TC	PI	TC	PI	TC	PI	TC	PI	TC	PI	TC	PI
			(kW)	(kW)	(kW)	(kW)	(kW)	(kW)	(kW)	(kW)	(kW)	(kW)	(kW)	(kW)	(kW)	(kW)	(kW)	(kW)
15.0	13.7	22.4	22.4	4.37	20.2	3.62	17.9	3.00	15.7	2.49	13.4	2.07	11.2	1.71	8.96	1.39	6.72	1.09
13.0	11.8	22.4	22.4	4.58	20.2	3.78	17.9	3.11	15.7	2.57	13.4	2.13	11.2	1.75	8.96	1.42	6.72	1.12
11.0	9.8	22.4	22.4	4.84	20.2	3.96	17.9	3.25	15.7	2.67	13.4	2.19	11.2	1.80	8.96	1.46	6.72	1.14
9.0	7.9	22.4	22.4	5.10	20.2	4.15	17.9	3.38	15.7	2.76	13.4	2.26	11.2	1.84	8.96	1.49	6.72	1.16
7.0	6.0	22.4	22.4	5.40	20.2	4.37	17.9	3.54	15.7	2.87	13.4	2.33	11.2	1.89	8.96	1.52	6.72	1.19
5.0	4.1	21.7	21.7	5.38	19.6	4.36	17.4	3.53	15.2	2.86	13.0	2.33	10.9	1.89	8.70	1.52	6.52	1.18
3.0	2.2	21.1	21.1	5.37	19.0	4.35	16.9	3.52	14.8	2.85	12.7	2.32	10.5	1.88	8.44	1.51	6.33	1.18
0.0	-0.7	20.1	20.1	5.34	18.1	4.33	16.1	3.50	14.1	2.84	12.1	2.31	10.0	1.87	8.04	1.51	6.03	1.17
-3.0	-3.7	19.1	19.1	5.32	17.2	4.30	15.2	3.48	13.3	2.83	11.4	2.30	9.53	1.86	7.62	1.50	5.72	1.17
-5.0	-5.6	18.4	18.4	5.30	16.6	4.29	14.7	3.47	12.9	2.82	11.0	2.29	9.20	1.86	7.36	1.49	5.52	1.16
-7.0	-7.6	17.7	17.7	5.28	15.9	4.28	14.2	3.46	12.4	2.81	10.6	2.28	8.86	1.85	7.09	1.49	5.31	1.16
-10	-10.5	16.7	16.7	5.26	15.0	4.26	13.4	3.45	11.7	2.79	10.0	2.27	8.36	1.84	6.69	1.48	5.01	1.16
-14.5	-15.0	15.2	15.2	5.22	13.6	4.23	12.1	3.42	10.6	2.77	9.10	2.25	7.58	1.83	6.07	1.47	4.55	1.15

TC : Total Capacity PI : Power Input
Indoor air temperature conditions : 20.0°C dry-bulb



MMY-MAP1006FT8P-E (10HP , 28kW system)

Cooling

Outdoor Unit Dry-Bulb (°C)		Outdoor Unit 100% Cooling Capacity (kW)	Compressor + Outdoor Fan Power consumption (kW)															
			100% Capacity		90% Capacity		80% Capacity		70% Capacity		60% Capacity		50% Capacity		40% Capacity		30% Capacity	
			TC	PI	TC	PI	TC	PI	TC	PI	TC	PI	TC	PI	TC	PI	TC	PI
			(kW)	(kW)	(kW)	(kW)	(kW)	(kW)	(kW)	(kW)	(kW)	(kW)	(kW)	(kW)	(kW)	(kW)	(kW)	(kW)
40 °C	26.1	26.1	8.60	23.5	6.70	20.8	5.13	18.2	3.86	15.6	2.88	13.0	2.15	10.4	1.67	7.82	1.41	
39 °C	26.5	26.5	8.47	23.8	6.60	21.2	5.05	18.5	3.80	15.9	2.83	13.2	2.12	10.6	1.65	7.94	1.39	
37 °C	27.3	27.3	8.22	24.5	6.40	21.8	4.90	19.1	3.69	16.4	2.75	13.6	2.06	10.9	1.60	8.18	1.35	
35 °C	28.0	28.0	7.96	25.2	6.20	22.4	4.75	19.6	3.57	16.8	2.66	14.0	1.99	11.2	1.55	8.40	1.30	
32 °C	28.0	28.0	7.27	25.2	5.68	22.4	4.36	19.6	3.29	16.8	2.47	14.0	1.87	11.2	1.47	8.40	1.25	
31 °C	28.0	28.0	6.67	25.2	5.22	22.4	4.02	19.6	3.05	16.8	2.30	14.0	1.75	11.2	1.39	8.40	1.20	
30 °C	28.0	28.0	6.40	25.2	5.01	22.4	3.86	19.6	2.94	16.8	2.22	14.0	1.70	11.2	1.36	8.40	1.18	
29 °C	28.0	28.0	6.15	25.2	4.82	22.4	3.72	19.6	2.83	16.8	2.15	14.0	1.65	11.2	1.32	8.40	1.15	
27 °C	28.0	28.0	5.68	25.2	4.46	22.4	3.45	19.6	2.64	16.8	2.01	14.0	1.55	11.2	1.26	8.40	1.10	
25 °C	28.0	28.0	5.27	25.2	4.14	22.4	3.21	19.6	2.46	16.8	1.88	14.0	1.46	11.2	1.19	8.40	1.06	
23 °C	28.0	28.0	5.00	25.2	3.93	22.4	3.05	19.6	2.35	16.8	1.80	14.0	1.41	11.2	1.16	8.40	1.03	
21 °C	28.0	28.0	4.86	25.2	3.83	22.4	2.98	19.6	2.30	16.8	1.77	14.0	1.39	11.2	1.15	8.40	1.03	
20 °C	28.0	28.0	4.80	25.2	3.79	22.4	2.95	19.6	2.27	16.8	1.76	14.0	1.38	11.2	1.14	8.40	1.03	
19 °C	28.0	28.0	4.75	25.2	3.74	22.4	2.92	19.6	2.25	16.8	1.74	14.0	1.38	11.2	1.14	8.40	1.03	
17 °C	28.0	28.0	4.65	25.2	3.67	22.4	2.86	19.6	2.22	16.8	1.72	14.0	1.36	11.2	1.14	8.40	1.03	
15 °C	28.0	28.0	4.56	25.2	3.61	22.4	2.82	19.6	2.19	16.8	1.70	14.0	1.35	11.2	1.13	8.40	1.02	

TC : Total Capacity PI : Power Input
Indoor air temperature conditions : 27.0°C dry-bulb / 19.0°C wet bulb

Heating

Outdoor Unit Dry-Bulb (°C)		Outdoor Unit 100% Heating Capacity (kW)	Compressor + Outdoor Fan Power consumption (kW)															
			100% Capacity		90% Capacity		80% Capacity		70% Capacity		60% Capacity		50% Capacity		40% Capacity		30% Capacity	
			TC	PI	TC	PI	TC	PI	TC	PI	TC	PI	TC	PI	TC	PI	TC	PI
			(kW)	(kW)	(kW)	(kW)	(kW)	(kW)	(kW)	(kW)	(kW)	(kW)	(kW)	(kW)	(kW)	(kW)	(kW)	(kW)
15.0	13.7	28.0	28.0	5.69	25.2	4.71	22.4	3.92	19.6	3.28	16.8	2.74	14.0	2.26	11.2	1.81	8.40	1.35
13.0	11.8	28.0	28.0	5.97	25.2	4.92	22.4	4.07	19.6	3.38	16.8	2.81	14.0	2.31	11.2	1.85	8.40	1.38
11.0	9.8	28.0	28.0	6.30	25.2	5.15	22.4	4.24	19.6	3.50	16.8	2.89	14.0	2.38	11.2	1.90	8.40	1.42
9.0	7.9	28.0	28.0	6.65	25.2	5.41	22.4	4.41	19.6	3.62	16.8	2.98	14.0	2.44	11.2	1.95	8.40	1.46
7.0	6.0	28.0	28.0	7.05	25.2	5.69	22.4	4.61	19.6	3.76	16.8	3.07	14.0	2.50	11.2	2.00	8.40	1.50
5.0	4.1	27.1	27.1	7.01	24.4	5.66	21.7	4.59	19.0	3.74	16.3	3.06	13.5	2.49	10.8	1.99	8.13	1.49
3.0	2.2	26.2	26.2	6.97	23.6	5.63	21.0	4.56	18.3	3.71	15.7	3.04	13.1	2.48	10.5	1.98	7.86	1.48
0.0	-0.7	24.8	24.8	6.91	22.3	5.58	19.9	4.52	17.4	3.68	14.9	3.01	12.4	2.45	9.93	1.96	7.45	1.47
-3.0	-3.7	23.4	23.4	6.84	21.1	5.52	18.7	4.48	16.4	3.65	14.0	2.98	11.7	2.43	9.36	1.94	7.02	1.45
-5.0	-5.6	22.5	22.5	6.80	20.3	5.49	18.0	4.45	15.8	3.63	13.5	2.97	11.3	2.42	9.00	1.93	6.75	1.45
-7.0	-7.6	21.6	21.6	6.76	19.4	5.46	17.2	4.42	15.1	3.60	12.9	2.95	10.8	2.40	8.62	1.92	6.47	1.44
-10	-10.5	20.2	20.2	6.70	18.2	5.41	16.1	4.38	14.1	3.57	12.1	2.92	10.1	2.38	8.07	1.90	6.05	1.42
-14.5	-15.0	18.0	18.0	6.60	16.2	5.33	14.4	4.32	12.6	3.52	10.8	2.88	9.02	2.35	7.22	1.87	5.41	1.40

TC : Total Capacity PI : Power Input
Indoor air temperature conditions : 20.0°C dry-bulb



MMY-MAP1406FT8P-E (14HP , 40kW system)

Cooling			Compressor + Outdoor Fan Power consumption (kW)																	
			Outdoor Unit Dry-Bulb (°C)	Outdoor Unit 100% Cooling Capacity (kW)	100% Capacity		90% Capacity		80% Capacity		70% Capacity		60% Capacity		50% Capacity		40% Capacity		30% Capacity	
					TC	PI	TC	PI	TC	PI	TC	PI	TC	PI	TC	PI	TC	PI	TC	PI
					(kW)	(kW)	(kW)	(kW)	(kW)	(kW)	(kW)	(kW)	(kW)	(kW)	(kW)	(kW)	(kW)	(kW)	(kW)	(kW)
40 °C	37.2	37.2	13.7	33.5	11.0	29.8	8.64	26.1	6.70	22.3	5.11	18.6	3.81	14.9	2.76	11.2	1.90			
39 °C	37.8	37.8	13.5	34.0	10.8	30.3	8.51	26.5	6.60	22.7	5.04	18.9	3.76	15.1	2.72	11.3	1.87			
37 °C	39.0	39.0	13.1	35.1	10.5	31.2	8.25	27.3	6.40	23.4	4.88	19.5	3.64	15.6	2.63	11.7	1.81			
35 °C	40.0	40.0	12.7	36.0	10.1	32.0	7.99	28.0	6.20	24.0	4.73	20.0	3.53	16.0	2.55	12.0	1.75			
33 °C	40.0	40.0	11.7	36.0	9.34	32.0	7.38	28.0	5.74	24.0	4.39	20.0	3.29	16.0	2.39	12.0	1.65			
31 °C	40.0	40.0	10.8	36.0	8.63	32.0	6.84	28.0	5.34	24.0	4.10	20.0	3.08	16.0	2.24	12.0	1.55			
30 °C	40.0	40.0	10.3	36.0	8.31	32.0	6.59	28.0	5.15	24.0	3.96	20.0	2.98	16.0	2.17	12.0	1.50			
29 °C	40.0	40.0	9.95	36.0	8.00	32.0	6.35	28.0	4.97	24.0	3.83	20.0	2.88	16.0	2.10	12.0	1.46			
27 °C	40.0	40.0	9.24	36.0	7.44	32.0	5.92	28.0	4.64	24.0	3.58	20.0	2.70	16.0	1.98	12.0	1.38			
25 °C	40.0	40.0	8.59	36.0	6.93	32.0	5.52	28.0	4.34	24.0	3.35	20.0	2.54	16.0	1.86	12.0	1.30			
23 °C	40.0	40.0	8.18	36.0	6.61	32.0	5.27	28.0	4.15	24.0	3.21	20.0	2.44	16.0	1.79	12.0	1.25			
21 °C	40.0	40.0	7.98	36.0	6.45	32.0	5.16	28.0	4.07	24.0	3.15	20.0	2.39	16.0	1.76	12.0	1.23			
20 °C	40.0	40.0	7.89	36.0	6.39	32.0	5.11	28.0	4.03	24.0	3.13	20.0	2.38	16.0	1.75	12.0	1.23			
19 °C	40.0	40.0	7.81	36.0	6.32	32.0	5.06	28.0	4.00	24.0	3.10	20.0	2.36	16.0	1.74	12.0	1.22			
17 °C	40.0	40.0	7.66	36.0	6.21	32.0	4.98	28.0	3.93	24.0	3.06	20.0	2.33	16.0	1.72	12.0	1.20			
15 °C	40.0	40.0	7.54	36.0	6.12	32.0	4.91	28.0	3.88	24.0	3.02	20.0	2.30	16.0	1.70	12.0	1.19			

TC : Total Capacity PI : Power Input
Indoor air temperature conditions : 27.0°C dry-bulb / 19.0°C wet bulb

Heating			Compressor + Outdoor Fan Power consumption (kW)																		
			Outdoor Unit Dry-Bulb (°C)	Outdoor Unit Wet-Bulb (°C)	Outdoor Unit 100% Heating Capacity (kW)	100% Capacity		90% Capacity		80% Capacity		70% Capacity		60% Capacity		50% Capacity		40% Capacity		30% Capacity	
						TC	PI	TC	PI	TC	PI	TC	PI	TC	PI	TC	PI	TC	PI	TC	PI
						(kW)	(kW)	(kW)	(kW)	(kW)	(kW)	(kW)	(kW)	(kW)	(kW)	(kW)	(kW)	(kW)	(kW)	(kW)	(kW)
15.0	13.7	40.0	40.0	8.49	36.0	7.01	32.0	5.80	28.0	4.81	24.0	3.99	20.0	3.31	16.0	2.71	12.0	2.16			
13.0	11.8	40.0	40.0	8.91	36.0	7.32	32.0	6.02	28.0	4.97	24.0	4.10	20.0	3.38	16.0	2.76	12.0	2.20			
11.0	9.8	40.0	40.0	9.40	36.0	7.68	32.0	6.28	28.0	5.15	24.0	4.23	20.0	3.47	16.0	2.82	12.0	2.24			
9.0	7.9	40.0	40.0	9.92	36.0	8.06	32.0	6.56	28.0	5.34	24.0	4.36	20.0	3.56	16.0	2.88	12.0	2.28			
7.0	6.0	40.0	40.0	10.5	36.0	8.49	32.0	6.86	28.0	5.55	24.0	4.50	20.0	3.65	16.0	2.95	12.0	2.33			
5.0	4.1	38.7	38.7	10.4	34.8	8.44	31.0	6.82	27.1	5.52	23.2	4.47	19.4	3.63	15.5	2.93	11.6	2.31			
3.0	2.2	37.4	37.4	10.4	33.7	8.39	29.9	6.78	26.2	5.49	22.5	4.45	18.7	3.61	15.0	2.91	11.2	2.30			
0.0	-0.7	35.5	35.5	10.3	31.9	8.32	28.4	6.72	24.8	5.44	21.3	4.41	17.7	3.58	14.2	2.89	10.6	2.28			
-3.0	-3.7	33.4	33.4	10.2	30.1	8.24	26.7	6.66	23.4	5.39	20.1	4.37	16.7	3.55	13.4	2.86	10.0	2.26			
-5.0	-5.6	32.1	32.1	10.1	28.9	8.19	25.7	6.62	22.5	5.36	19.3	4.34	16.1	3.52	12.9	2.84	9.64	2.24			
-7.0	-7.6	30.8	30.8	10.1	27.7	8.14	24.6	6.58	21.6	5.32	18.5	4.32	15.4	3.50	12.3	2.83	9.24	2.23			
-10	-10.5	28.8	28.8	10.0	25.9	8.07	23.1	6.52	20.2	5.27	17.3	4.28	14.4	3.47	11.5	2.80	8.65	2.21			
-14.5	-15.0	25.8	25.8	9.83	23.2	7.95	20.6	6.43	18.0	5.20	15.5	4.22	12.9	3.42	10.3	2.76	7.73	2.18			

TC : Total Capacity PI : Power Input
Indoor air temperature conditions : 20.0°C dry-bulb

MMY-MAP1606FT8P-E (16HP , 45kW system)

Cooling			Compressor + Outdoor Fan Power consumption (kW)																	
			Outdoor Unit Dry-Bulb (°C)	Outdoor Unit 100% Cooling Capacity (kW)	100% Capacity		90% Capacity		80% Capacity		70% Capacity		60% Capacity		50% Capacity		40% Capacity		30% Capacity	
					TC	PI	TC	PI	TC	PI	TC	PI	TC	PI	TC	PI	TC	PI	TC	PI
					(kW)	(kW)	(kW)	(kW)	(kW)	(kW)	(kW)	(kW)	(kW)	(kW)	(kW)	(kW)	(kW)	(kW)	(kW)	(kW)
40 °C	41.9	41.9	15.0	37.7	11.9	33.5	9.24	29.3	7.08	25.1	5.32	20.9	3.90	16.8	2.78	12.6	1.88			
39 °C	42.6	42.6	14.8	38.3	11.7	34.0	9.11	29.8	6.97	25.5	5.24	21.3	3.84	17.0	2.73	12.8	1.85			
37 °C	43.8	43.8	14.3	39.4	11.3	35.1	8.83	30.7	6.76	26.3	5.08	21.9	3.73	17.5	2.65	13.1	1.80			
35 °C	45.0	45.0	13.9	40.5	11.0	36.0	8.55	31.5	6.55	27.0	4.92	22.5	3.61	18.0	2.57	13.5	1.74			
33 °C	45.0	45.0	12.7	40.5	10.1	36.0	7.88	31.5	6.05	27.0	4.56	22.5	3.36	18.0	2.40	13.5	1.63			
31 °C	45.0	45.0	11.7	40.5	9.31	36.0	7.28	31.5	5.61	27.0	4.24	22.5	3.14	18.0	2.25	13.5	1.53			
30 °C	45.0	45.0	11.3	40.5	8.95	36.0	7.01	31.5	5.41	27.0	4.10	22.5	3.03	18.0	2.18	13.5	1.49			
29 °C	45.0	45.0	10.8	40.5	8.61	36.0	6.76	31.5	5.22	27.0	3.96	22.5	2.93	18.0	2.11	13.5	1.44			
27 °C	45.0	45.0	10.0	40.5	7.99	36.0	6.28	31.5	4.86	27.0	3.70	22.5	2.75	18.0	1.98	13.5	1.36			
25 °C	45.0	45.0	9.31	40.5	7.43	36.0	5.85	31.5	4.54	27.0	3.46	22.5	2.58	18.0	1.86	13.5	1.28			
23 °C	45.0	45.0	8.85	40.5	7.08	36.0	5.58	31.5	4.34	27.0	3.31	22.5	2.47	18.0	1.79	13.5	1.23			
21 °C	45.0	45.0	8.63	40.5	6.91	36.0	5.45	31.5	4.24	27.0	3.25	22.5	2.43	18.0	1.76	13.5	1.22			
20 °C	45.0	45.0	8.53	40.5	6.83	36.0	5.40	31.5	4.20	27.0	3.22	22.5	2.41	18.0	1.75	13.5	1.21			
19 °C	45.0	45.0	8.44	40.5	6.76	36.0	5.35	31.5	4.17	27.0	3.19	22.5	2.39	18.0	1.74	13.5	1.20			
17 °C	45.0	45.0	8.27	40.5	6.63	36.0	5.25	31.5	4.10	27.0	3.14	22.5	2.36	18.0	1.72	13.5	1.19			
15 °C	45.0	45.0	8.13	40.5	6.53	36.0	5.17	31.5	4.04	27.0	3.10	22.5	2.33	18.0	1.70	13.5	1.18			

TC : Total Capacity PI : Power Input
Indoor air temperature conditions : 27.0°C dry-bulb / 19.0°C wet bulb

Heating			Compressor + Outdoor Fan Power consumption (kW)																		
			Outdoor Unit Dry-Bulb (°C)	Outdoor Unit Wet-Bulb (°C)	Outdoor Unit 100% Heating Capacity (kW)	100% Capacity		90% Capacity		80% Capacity		70% Capacity		60% Capacity		50% Capacity		40% Capacity		30% Capacity	
						TC	PI	TC	PI	TC	PI	TC	PI	TC	PI	TC	PI	TC	PI	TC	PI
						(kW)	(kW)	(kW)	(kW)	(kW)	(kW)	(kW)	(kW)	(kW)	(kW)	(kW)	(kW)	(kW)	(kW)	(kW)	(kW)
15.0	13.7	45.0	45.0	10.0	40.5	8.35	36.0	6.92	31.5	5.71	27.0	4.68	22.5	3.81	18.0	3.09	13.5	2.47			
13.0	11.8	45.0	45.0	10.5	40.5	8.71	36.0	7.19	31.5	5.90	27.0	4.82	22.5	3.91	18.0	3.15	13.5	2.51			
11.0	9.8	45.0	45.0	11.0	40.5	9.12	36.0	7.50	31.5	6.13	27.0	4.98	22.5	4.02	18.0	3.22	13.5	2.55			
9.0	7.9	45.0	45.0	11.6	40.5	9.55	36.0	7.82	31.5	6.36	27.0	5.14	22.5	4.13	18.0	3.29	13.5	2.60			
7.0	6.0	45.0	45.0	12.2	40.5	10.0	36.0	8.17	31.5	6.62	27.0	5.33	22.5	4.26	18.0	3.37	13.5	2.65			
5.0	4.1	43.4	43.4	12.1	39.0	9.95	34.7	8.11	30.4	6.57	26.0	5.29	21.7	4.22	17.4	3.35	13.0	2.63			
3.0	2.2	41.8	41.8	12.0	37.6	9.87	33.4	8.05	29.2	6.52	25.1	5.24	20.9	4.19	16.7	3.32	12.5	2.61			
0.0	-0.7	39.3	39.3	11.9	35.4	9.75	31.5	7.95	27.5	6.44	23.6	5.18	19.7	4.14	15.7	3.28	11.8	2.58			
-3.0	-3.7	36.8	36.8	11.7	33.1	9.63	29.4	7.86	25.7	6.36	22.1	5.12	18.4	4.09	14.7	3.24	11.0	2.54			
-5.0	-5.6	35.2	35.2	11.6	31.6	9.56	28.1	7.79	24.6	6.31	21.1	5.08	17.6	4.06	14.1	3.22	10.5	2.52			
-7.0	-7.6	33.5	33.5	11.5	30.1	9.48	26.8	7.73	23.4	6.26	20.1	5.04	16.7	4.02	13.4	3.19	10.0	2.50			
-10	-10.5	31.0	31.0	11.4	27.9	9.36	24.8	7.63	21.7	6.18	18.6	4.97	15.5	3.97	12.4	3.15	9.30	2.47			
-14.5	-15.0	27.2	27.2	11.2	24.5	9.18	21.8	7.49	19.0	6.06	16.3	4.88	13.6	3.90	10.9	3.09	8.16	2.42			

TC : Total Capacity PI : Power Input
Indoor air temperature conditions : 20.0°C dry-bulb



MMY-MAP1806FT8P-E (18HP , 50.4kW system)

Outdoor Unit Dry-Bulb (°C)		Outdoor Unit 100% Cooling Capacity (kW)	Compressor + Outdoor Fan Power consumption (kW)															
			100% Capacity		90% Capacity		80% Capacity		70% Capacity		60% Capacity		50% Capacity		40% Capacity		30% Capacity	
			TC	PI	TC	PI	TC	PI	TC	PI	TC	PI	TC	PI	TC	PI	TC	PI
			(kW)	(kW)	(kW)	(kW)	(kW)	(kW)	(kW)	(kW)	(kW)	(kW)	(kW)	(kW)	(kW)	(kW)	(kW)	(kW)
40 °C		46.9	17.3	42.2	13.3	37.5	10.0	32.8	7.43	28.1	5.47	23.5	4.01	18.8	2.98	14.1	2.28	
39 °C		47.7	17.0	42.9	13.1	38.1	9.85	33.4	7.32	28.6	5.39	23.8	3.95	19.1	2.93	14.3	2.25	
37 °C		49.1	16.5	44.2	12.7	39.3	9.55	34.4	7.10	29.4	5.22	24.5	3.83	19.6	2.85	14.7	2.18	
35 °C		50.4	16.0	45.4	12.3	40.3	9.25	35.3	6.88	30.2	5.06	25.2	3.71	20.2	2.76	15.1	2.11	
33 °C		50.4	14.6	45.4	11.2	40.3	8.47	35.3	6.33	30.2	4.68	25.2	3.46	20.2	2.59	15.1	2.01	
31 °C		50.4	13.3	45.4	10.3	40.3	7.80	35.3	5.85	30.2	4.35	25.2	3.24	20.2	2.45	15.1	1.91	
30 °C		50.4	12.8	45.4	9.84	40.3	7.49	35.3	5.63	30.2	4.20	25.2	3.14	20.2	2.38	15.1	1.86	
29 °C		50.4	12.2	45.4	9.45	40.3	7.20	35.3	5.42	30.2	4.05	25.2	3.04	20.2	2.31	15.1	1.82	
27 °C		50.4	11.3	45.4	8.73	40.3	6.67	35.3	5.04	30.2	3.79	25.2	2.85	20.2	2.19	15.1	1.73	
25 °C		50.4	10.4	45.4	8.09	40.3	6.20	35.3	4.70	30.2	3.54	25.2	2.68	20.2	2.07	15.1	1.64	
23 °C		50.4	9.88	45.4	7.67	40.3	5.89	35.3	4.48	30.2	3.39	25.2	2.58	20.2	2.00	15.1	1.59	
21 °C		50.4	9.59	45.4	7.47	40.3	5.74	35.3	4.38	30.2	3.33	25.2	2.54	20.2	1.97	15.1	1.58	
20 °C		50.4	9.47	45.4	7.37	40.3	5.68	35.3	4.33	30.2	3.30	25.2	2.52	20.2	1.96	15.1	1.58	
19 °C		50.4	9.35	45.4	7.29	40.3	5.62	35.3	4.29	30.2	3.27	25.2	2.51	20.2	1.95	15.1	1.57	
17 °C		50.4	9.15	45.4	7.14	40.3	5.51	35.3	4.22	30.2	3.22	25.2	2.48	20.2	1.94	15.1	1.56	
15 °C		50.4	8.97	45.4	7.01	40.3	5.42	35.3	4.16	30.2	3.18	25.2	2.45	20.2	1.92	15.1	1.56	

TC : Total Capacity PI : Power Input
Indoor air temperature conditions : 27.0°C dry-bulb / 19.0°C wet bulb

Outdoor Unit Dry-Bulb (°C)		Outdoor Unit 100% Heating Capacity (kW)	Compressor + Outdoor Fan Power consumption (kW)															
			100% Capacity		90% Capacity		80% Capacity		70% Capacity		60% Capacity		50% Capacity		40% Capacity		30% Capacity	
			TC	PI	TC	PI	TC	PI	TC	PI	TC	PI	TC	PI	TC	PI	TC	PI
			(kW)	(kW)	(kW)	(kW)	(kW)	(kW)	(kW)	(kW)	(kW)	(kW)	(kW)	(kW)	(kW)	(kW)	(kW)	(kW)
15.0	13.7	50.4	11.4	45.4	9.62	40.3	8.07	35.3	6.72	30.2	5.53	25.2	4.47	20.2	3.50	15.1	2.58	
13.0	11.8	50.4	11.9	45.4	10.0	40.3	8.36	35.3	6.94	30.2	5.70	25.2	4.59	20.2	3.59	15.1	2.64	
11.0	9.8	50.4	12.5	45.4	10.4	40.3	8.69	35.3	7.19	30.2	5.89	25.2	4.73	20.2	3.69	15.1	2.72	
9.0	7.9	50.4	13.0	45.4	10.9	40.3	9.04	35.3	7.45	30.2	6.08	25.2	4.87	20.2	3.79	15.1	2.79	
7.0	6.0	50.4	13.7	45.4	11.4	40.3	9.42	35.3	7.73	30.2	6.29	25.2	5.02	20.2	3.90	15.1	2.87	
5.0	4.1	48.8	13.6	43.9	11.3	39.0	9.36	34.1	7.69	29.3	6.25	24.4	5.00	19.5	3.88	14.6	2.85	
3.0	2.2	47.2	13.5	42.4	11.3	37.7	9.31	33.0	7.64	28.3	6.21	23.6	4.97	18.9	3.86	14.1	2.83	
0.0	-0.7	44.7	13.4	40.2	11.2	35.7	9.23	31.3	7.58	26.8	6.16	22.3	4.92	17.9	3.82	13.4	2.81	
-3.0	-3.7	42.1	13.3	37.9	11.1	33.7	9.14	29.5	7.51	25.3	6.10	21.1	4.88	16.8	3.79	12.6	2.78	
-5.0	-5.6	40.5	13.2	36.5	11.0	32.4	9.09	28.4	7.46	24.3	6.07	20.3	4.85	16.2	3.77	12.2	2.77	
-7.0	-7.6	38.8	13.1	34.9	10.9	31.0	9.03	27.2	7.42	23.3	6.03	19.4	4.82	15.5	3.74	11.6	2.75	
-10	-10.5	36.3	13.0	32.7	10.8	29.1	8.95	25.4	7.35	21.8	5.97	18.2	4.78	14.5	3.71	10.9	2.72	
-14.5	-15.0	32.5	12.8	29.2	10.7	26.0	8.82	22.7	7.24	19.5	5.89	16.2	4.71	13.0	3.66	9.75	2.69	

TC : Total Capacity PI : Power Input
Indoor air temperature conditions : 20.0°C dry-bulb



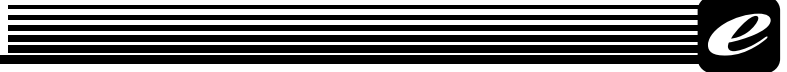
MMY-MAP2006FT8P-E (20HP, 56.0kW system)

Outdoor Unit Dry-Bulb (°C)		Outdoor Unit 100% Cooling Capacity (kW)	Compressor + Outdoor Fan Power consumption (kW)															
			100% Capacity		90% Capacity		80% Capacity		70% Capacity		60% Capacity		50% Capacity		40% Capacity		30% Capacity	
			TC	PI	TC	PI	TC	PI	TC	PI	TC	PI	TC	PI	TC	PI	TC	PI
			(kW)	(kW)	(kW)	(kW)	(kW)	(kW)	(kW)	(kW)	(kW)	(kW)	(kW)	(kW)	(kW)	(kW)	(kW)	(kW)
40 °C		52.1	52.1	20.1	46.9	16.2	41.7	12.9	36.5	10.2	31.3	7.88	26.1	5.94	20.8	4.27	15.6	2.79
39 °C		53.0	53.0	19.8	47.7	16.0	42.4	12.7	37.1	10.0	31.8	7.76	26.5	5.85	21.2	4.21	15.9	2.74
37 °C		54.5	54.5	19.2	49.1	15.5	43.6	12.3	38.2	9.72	32.7	7.53	27.3	5.68	21.8	4.08	16.4	2.66
35 °C		56.0	56.0	18.6	50.4	15.0	44.8	12.0	39.2	9.41	33.6	7.29	28.0	5.50	22.4	3.95	16.8	2.58
33 °C		56.0	56.0	17.1	50.4	13.8	44.8	11.1	39.2	8.74	33.6	6.79	28.0	5.13	22.4	3.69	16.8	2.40
31 °C		56.0	56.0	15.8	50.4	12.8	44.8	10.3	39.2	8.14	33.6	6.34	28.0	4.80	22.4	3.46	16.8	2.24
30 °C		56.0	56.0	15.2	50.4	12.3	44.8	9.91	39.2	7.86	33.6	6.13	28.0	4.64	22.4	3.35	16.8	2.17
29 °C		56.0	56.0	14.7	50.4	11.9	44.8	9.57	39.2	7.60	33.6	5.93	28.0	4.50	22.4	3.24	16.8	2.10
27 °C		56.0	56.0	13.6	50.4	11.1	44.8	8.93	39.2	7.11	33.6	5.56	28.0	4.22	22.4	3.04	16.8	1.97
25 °C		56.0	56.0	12.7	50.4	10.3	44.8	8.35	39.2	6.66	33.6	5.21	28.0	3.96	22.4	2.85	16.8	1.84
23 °C		56.0	56.0	12.1	50.4	9.87	44.8	7.98	39.2	6.37	33.6	5.00	28.0	3.80	22.4	2.74	16.8	1.77
21 °C		56.0	56.0	11.8	50.4	9.66	44.8	7.82	39.2	6.25	33.6	4.91	28.0	3.73	22.4	2.69	16.8	1.73
20 °C		56.0	56.0	11.7	50.4	9.56	44.8	7.75	39.2	6.20	33.6	4.87	28.0	3.70	22.4	2.67	16.8	1.72
19 °C		56.0	56.0	11.6	50.4	9.47	44.8	7.68	39.2	6.15	33.6	4.83	28.0	3.68	22.4	2.65	16.8	1.70
17 °C		56.0	56.0	11.4	50.4	9.32	44.8	7.56	39.2	6.06	33.6	4.76	28.0	3.63	22.4	2.61	16.8	1.68
15 °C		56.0	56.0	11.2	50.4	9.18	44.8	7.46	39.2	5.98	33.6	4.70	28.0	3.59	22.4	2.58	16.8	1.66

TC : Total Capacity PI : Power Input
Indoor air temperature conditions : 27.0°C dry-bulb / 19.0°C wet bulb

Outdoor Unit Dry-Bulb (°C)		Outdoor Unit 100% Heating Capacity (kW)	Compressor + Outdoor Fan Power consumption (kW)															
			100% Capacity		90% Capacity		80% Capacity		70% Capacity		60% Capacity		50% Capacity		40% Capacity		30% Capacity	
			TC	PI	TC	PI	TC	PI	TC	PI	TC	PI	TC	PI	TC	PI	TC	PI
			(kW)	(kW)	(kW)	(kW)	(kW)	(kW)	(kW)	(kW)	(kW)	(kW)	(kW)	(kW)	(kW)	(kW)	(kW)	(kW)
15.0	13.7	56.0	56.0	13.3	50.4	11.2	44.8	9.42	39.2	7.84	33.6	6.44	28.0	5.17	22.4	3.97	16.8	2.82
13.0	11.8	56.0	56.0	13.8	50.4	11.6	44.8	9.75	39.2	8.10	33.6	6.64	28.0	5.32	22.4	4.09	16.8	2.90
11.0	9.8	56.0	56.0	14.5	50.4	12.1	44.8	10.1	39.2	8.39	33.6	6.86	28.0	5.48	22.4	4.21	16.8	3.00
9.0	7.9	56.0	56.0	15.1	50.4	12.7	44.8	10.5	39.2	8.70	33.6	7.09	28.0	5.65	22.4	4.34	16.8	3.09
7.0	6.0	56.0	56.0	15.9	50.4	13.2	44.8	11.0	39.2	9.03	33.6	7.33	28.0	5.84	22.4	4.48	16.8	3.19
5.0	4.1	54.0	54.0	15.8	48.6	13.1	43.2	10.9	37.8	8.96	32.4	7.28	27.0	5.79	21.6	4.44	16.2	3.17
3.0	2.2	52.0	52.0	15.7	46.8	13.0	41.6	10.8	36.4	8.89	31.2	7.22	26.0	5.75	20.8	4.41	15.6	3.14
0.0	-0.7	48.9	48.9	15.5	44.0	12.9	39.1	10.7	34.2	8.78	29.4	7.14	24.5	5.68	19.6	4.36	14.7	3.10
-3.0	-3.7	45.8	45.8	15.3	41.2	12.7	36.6	10.5	32.0	8.67	27.5	7.05	22.9	5.61	18.3	4.30	13.7	3.07
-5.0	-5.6	43.8	43.8	15.2	39.4	12.6	35.0	10.5	30.6	8.61	26.3	6.99	21.9	5.57	17.5	4.27	13.1	3.04
-7.0	-7.6	41.6	41.6	15.0	37.5	12.5	33.3	10.4	29.2	8.53	25.0	6.93	20.8	5.52	16.7	4.23	12.5	3.02
-10	-10.5	38.6	38.6	14.8	34.7	12.4	30.9	10.3	27.0	8.43	23.2	6.85	19.3	5.45	15.4	4.18	11.6	2.98
-14.5	-15.0	33.8	33.8	14.6	30.5	12.1	27.1	10.1	23.7	8.27	20.3	6.72	16.9	5.35	13.5	4.10	10.2	2.92

TC : Total Capacity PI : Power Input
Indoor air temperature conditions : 20.0°C dry-bulb



MMY-MAP2216FT8P-E (22HP, 61.5kW system)

Cooling

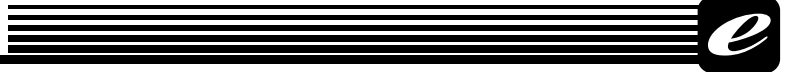
Outdoor Unit (°C)		Outdoor Unit 100% Capacity (kW)	Compressor + Outdoor Fan Power consumption (kW)															
			100%		90%		80%		70%		60%		50%		40%		30%	
			TC (kW)	PI (kW)	TC (kW)	PI (kW)	TC (kW)	PI (kW)	TC (kW)	PI (kW)	TC (kW)	PI (kW)	TC (kW)	PI (kW)	TC (kW)	PI (kW)	TC (kW)	PI (kW)
40 °C	57.2	57.2	19.1	51.5	15.1	45.8	11.8	40.1	9.01	34.3	6.80	28.6	5.08	22.9	3.79	17.2	2.87	
39 °C	58.2	58.2	18.9	52.3	14.9	46.5	11.6	40.7	8.88	34.9	6.70	29.1	5.01	23.3	3.73	17.4	2.83	
37 °C	59.9	59.9	18.3	53.9	14.4	47.9	11.2	41.9	8.61	35.9	6.50	29.9	4.86	24.0	3.62	18.0	2.74	
35 °C	61.5	61.5	17.7	55.3	14.0	49.2	10.9	43.0	8.34	36.9	6.29	30.7	4.70	24.6	3.51	18.4	2.65	
33 °C	61.5	61.5	16.2	55.4	12.8	49.2	10.0	43.1	7.71	36.9	5.85	30.8	4.39	24.6	3.30	18.5	2.52	
31 °C	61.5	61.5	14.9	55.4	11.8	49.2	9.27	43.1	7.15	36.9	5.45	30.8	4.12	24.6	3.11	18.5	2.39	
30 °C	61.5	61.5	14.3	55.4	11.4	49.2	8.92	43.1	6.89	36.9	5.26	30.8	3.99	24.6	3.02	18.5	2.33	
29 °C	61.5	61.5	13.8	55.4	11.0	49.2	8.60	43.1	6.65	36.9	5.09	30.8	3.86	24.6	2.94	18.5	2.28	
27 °C	61.5	61.5	12.8	55.4	10.2	49.2	7.99	43.1	6.20	36.9	4.76	30.8	3.63	24.6	2.78	18.5	2.16	
25 °C	61.5	61.5	11.9	55.4	9.46	49.2	7.45	43.1	5.79	36.9	4.46	30.8	3.41	24.6	2.62	18.5	2.05	
23 °C	61.5	61.5	11.3	55.4	9.01	49.2	7.10	43.1	5.54	36.9	4.27	30.8	3.28	24.6	2.53	18.5	1.99	
21 °C	61.5	61.5	11.0	55.4	8.79	49.2	6.94	43.1	5.42	36.9	4.20	30.8	3.23	24.6	2.50	18.5	1.98	
20 °C	61.5	61.5	10.9	55.4	8.69	49.2	6.87	43.1	5.37	36.9	4.16	30.8	3.21	24.6	2.49	18.5	1.97	
19 °C	61.5	61.5	10.7	55.4	8.60	49.2	6.80	43.1	5.32	36.9	4.13	30.8	3.19	24.6	2.48	18.5	1.96	
17 °C	61.5	61.5	10.5	55.4	8.44	49.2	6.69	43.1	5.24	36.9	4.07	30.8	3.15	24.6	2.46	18.5	1.95	
15 °C	61.5	61.5	10.4	55.4	8.31	49.2	6.59	43.1	5.17	36.9	4.02	30.8	3.12	24.6	2.44	18.5	1.94	

TC : Total Capacity PI : Power Input
Indoor air temperature conditions : 27.0°C dry-bulb / 19.0°C wet bulb

Heating

Outdoor Unit Dry-Bulb (°C) / Wet-Bulb (°C)		Outdoor Unit 100% Heating Capacity (kW)	Compressor + Outdoor Fan Power consumption (kW)															
			100% Capacity		90% Capacity		80% Capacity		70% Capacity		60% Capacity		50% Capacity		40% Capacity		30% Capacity	
			TC (kW)	PI (kW)	TC (kW)	PI (kW)	TC (kW)	PI (kW)	TC (kW)	PI (kW)	TC (kW)	PI (kW)	TC (kW)	PI (kW)	TC (kW)	PI (kW)	TC (kW)	PI (kW)
15.0	13.7	61.5	61.5	12.8	55.4	10.7	49.2	8.91	43.1	7.43	36.9	6.17	30.8	5.04	24.6	3.97	18.5	2.88
13.0	11.8	61.5	61.5	13.4	55.4	11.1	49.2	9.24	43.1	7.67	36.9	6.34	30.8	5.17	24.6	4.07	18.5	2.97
11.0	9.8	61.5	61.5	14.1	55.4	11.7	49.2	9.62	43.1	7.94	36.9	6.54	30.8	5.31	24.6	4.18	18.5	3.05
9.0	7.9	61.5	61.5	14.9	55.4	12.2	49.2	10.0	43.1	8.22	36.9	6.74	30.8	5.46	24.6	4.30	18.5	3.14
7.0	6.0	61.5	61.5	15.7	55.4	12.8	49.2	10.5	43.1	8.54	36.9	6.96	30.8	5.62	24.6	4.42	18.5	3.24
5.0	4.1	59.4	59.4	15.6	53.5	12.7	47.5	10.4	41.6	8.48	35.6	6.91	29.7	5.59	23.8	4.39	17.8	3.21
3.0	2.2	57.3	57.3	15.5	51.6	12.6	45.8	10.3	40.1	8.42	34.4	6.87	28.6	5.55	22.9	4.36	17.2	3.19
0.0	-0.7	54.1	54.1	15.4	48.7	12.5	43.3	10.2	37.9	8.33	32.5	6.79	27.0	5.49	21.6	4.31	16.2	3.16
-3.0	-3.7	50.8	50.8	15.2	45.7	12.4	40.6	10.1	35.5	8.24	30.5	6.72	25.4	5.43	20.3	4.27	15.2	3.13
-5.0	-5.6	48.7	48.7	15.1	43.8	12.3	38.9	10.0	34.1	8.18	29.2	6.67	24.3	5.39	19.5	4.24	14.6	3.10
-7.0	-7.6	46.5	46.5	15.0	41.8	12.2	37.2	9.95	32.5	8.12	27.9	6.62	23.2	5.35	18.6	4.20	13.9	3.08
-10	-10.5	43.3	43.3	14.8	38.9	12.1	34.6	9.84	30.3	8.03	26.0	6.55	21.6	5.29	17.3	4.16	13.0	3.05
-14.5	-15.0	38.3	38.3	14.6	34.5	11.9	30.6	9.67	26.8	7.90	23.0	6.44	19.1	5.20	15.3	4.09	11.5	3.00

TC : Total Capacity PI : Power Input
Indoor air temperature conditions : 20.0°C dry-bulb



MMY-AP2416FT8P-E (24HP, 68kW system)

Cooling

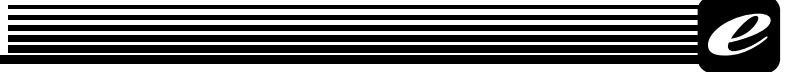
Outdoor Unit (°C)		Outdoor Unit 100% Capacity (kW)	Compressor + Outdoor Fan Power consumption (kW)															
			100%		90%		80%		70%		60%		50%		40%		30%	
			TC (kW)	PI (kW)	TC (kW)	PI (kW)	TC (kW)	PI (kW)	TC (kW)	PI (kW)	TC (kW)	PI (kW)	TC (kW)	PI (kW)	TC (kW)	PI (kW)	TC (kW)	PI (kW)
40 °C	63.3	63.3	22.3	57.0	17.7	50.6	13.8	44.3	10.6	38.0	7.99	31.6	5.97	25.3	4.43	19.0	3.31	
39 °C	64.3	64.3	22.0	57.9	17.4	51.4	13.6	45.0	10.4	38.6	7.87	32.2	5.88	25.7	4.36	19.3	3.26	
37 °C	66.2	66.2	21.3	59.6	16.9	53.0	13.2	46.4	10.1	39.7	7.63	33.1	5.70	26.5	4.23	19.9	3.16	
35 °C	68.0	68.0	20.7	61.2	16.3	54.4	12.7	47.6	9.77	40.8	7.39	34.0	5.52	27.2	4.10	20.4	3.06	
33 °C	68.0	68.0	18.9	61.2	15.0	54.4	11.7	47.6	9.04	40.8	6.86	34.0	5.16	27.2	3.85	20.4	2.90	
31 °C	68.0	68.0	17.4	61.2	13.8	54.4	10.9	47.6	8.39	40.8	6.40	34.0	4.83	27.2	3.63	20.4	2.75	
30 °C	68.0	68.0	16.7	61.2	13.3	54.4	10.5	47.6	8.09	40.8	6.18	34.0	4.68	27.2	3.53	20.4	2.68	
29 °C	68.0	68.0	16.1	61.2	12.8	54.4	10.1	47.6	7.80	40.8	5.97	34.0	4.53	27.2	3.43	20.4	2.61	
27 °C	68.0	68.0	14.9	61.2	11.9	54.4	9.37	47.6	7.28	40.8	5.59	34.0	4.26	27.2	3.23	20.4	2.48	
25 °C	68.0	68.0	13.9	61.2	11.1	54.4	8.73	47.6	6.80	40.8	5.24	34.0	4.00	27.2	3.05	20.4	2.35	
23 °C	68.0	68.0	13.2	61.2	10.5	54.4	8.33	47.6	6.50	40.8	5.02	34.0	3.85	27.2	2.95	20.4	2.28	
21 °C	68.0	68.0	12.8	61.2	10.3	54.4	8.14	47.6	6.36	40.8	4.93	34.0	3.79	27.2	2.91	20.4	2.26	
20 °C	68.0	68.0	12.7	61.2	10.2	54.4	8.05	47.6	6.30	40.8	4.89	34.0	3.76	27.2	2.90	20.4	2.25	
19 °C	68.0	68.0	12.6	61.2	10.1	54.4	7.98	47.6	6.25	40.8	4.85	34.0	3.74	27.2	2.88	20.4	2.25	
17 °C	68.0	68.0	12.3	61.2	9.88	54.4	7.84	47.6	6.15	40.8	4.78	34.0	3.69	27.2	2.85	20.4	2.23	
15 °C	68.0	68.0	12.1	61.2	9.72	54.4	7.72	47.6	6.07	40.8	4.72	34.0	3.65	27.2	2.83	20.4	2.22	

TC : Total Capacity PI : Power Input
Indoor air temperature conditions : 27.0°C dry-bulb / 19.0°C wet bulb

Heating

Outdoor Unit Dry-Bulb (°C) / Wet-Bulb (°C)		Outdoor Unit 100% Heating Capacity (kW)	Compressor + Outdoor Fan Power consumption (kW)															
			100% Capacity		90% Capacity		80% Capacity		70% Capacity		60% Capacity		50% Capacity		40% Capacity		30% Capacity	
			TC (kW)	PI (kW)	TC (kW)	PI (kW)	TC (kW)	PI (kW)	TC (kW)	PI (kW)	TC (kW)	PI (kW)	TC (kW)	PI (kW)	TC (kW)	PI (kW)	TC (kW)	PI (kW)
15.0	13.7	68.0	68.0	14.2	61.2	11.7	54.4	9.73	47.6	8.09	40.8	6.73	34.0	5.56	27.2	4.52	20.4	3.51
13.0	11.8	68.0	68.0	14.9	61.2	12.2	54.4	10.1	47.6	8.34	40.8	6.91	34.0	5.69	27.2	4.62	20.4	3.58
11.0	9.8	68.0	68.0	15.7	61.2	12.8	54.4	10.5	47.6	8.64	40.8	7.12	34.0	5.84	27.2	4.72	20.4	3.66
9.0	7.9	68.0	68.0	16.6	61.2	13.5	54.4	11.0	47.6	8.96	40.8	7.33	34.0	5.99	27.2	4.83	20.4	3.74
7.0	6.0	68.0	68.0	17.5	61.2	14.2	54.4	11.5	47.6	9.31	40.8	7.57	34.0	6.16	27.2	4.95	20.4	3.82
5.0	4.1	65.8	65.8	17.4	59.2	14.1	52.6	11.4	46.1	9.25	39.5	7.53	32.9	6.12	26.3	4.92	19.7	3.80
3.0	2.2	63.6	63.6	17.3	57.3	14.0	50.9	11.3	44.5	9.20	38.2	7.49	31.8	6.09	25.4	4.89	19.1	3.78
0.0	-0.7	60.3	60.3	17.2	54.3	13.9	48.2	11.2	42.2	9.12	36.2	7.42	30.1	6.03	24.1	4.85	18.1	3.75
-3.0	-3.7	56.8	56.8	17.0	51.2	13.8	45.5	11.1	39.8	9.03	34.1	7.35	28.4	5.98	22.7	4.80	17.1	3.71
-5.0	-5.6	54.6	54.6	16.9	49.2	13.7	43.7	11.1	38.3	8.98	32.8	7.31	27.3	5.94	21.9	4.77	16.4	3.69
-7.0	-7.6	52.3	52.3	16.8	47.1	13.6	41.9	11.0	36.6	8.93	31.4	7.26	26.2	5.91	20.9	4.74	15.7	3.67
-10	-10.5	49.0	49.0	16.7	44.1	13.5	39.2	10.9	34.3	8.84	29.4	7.20	24.5	5.85	19.6	4.70	14.7	3.63
-14.5	-15.0	43.8	43.8	16.4	39.4	13.3	35.1	10.7	30.7	8.72	26.3	7.09	21.9	5.77	17.5	4.63	13.1	3.58

TC : Total Capacity PI : Power Input
Indoor air temperature conditions : 20.0°C dry-bulb



MMY-AP2616FT8P-E (26HP, 73.5kW system)

Cooling

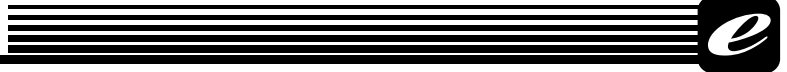
Outdoor Unit (°C)		Outdoor Unit 100% Capacity (kW)	Compressor + Outdoor Fan Power consumption (kW)															
			100%		90%		80%		70%		60%		50%		40%		30%	
			TC (kW)	PI (kW)	TC (kW)	PI (kW)	TC (kW)	PI (kW)	TC (kW)	PI (kW)	TC (kW)	PI (kW)	TC (kW)	PI (kW)	TC (kW)	PI (kW)	TC (kW)	PI (kW)
40 °C		68.4	68.4	24.3	61.6	19.4	54.7	15.3	47.9	11.9	41.0	9.04	34.2	6.74	27.4	4.88	20.5	3.35
39 °C		69.5	69.5	23.9	62.6	19.1	55.6	15.0	48.7	11.7	41.7	8.90	34.8	6.64	27.8	4.80	20.9	3.31
37 °C		71.6	71.6	23.2	64.4	18.5	57.3	14.6	50.1	11.3	42.9	8.63	35.8	6.44	28.6	4.66	21.5	3.21
35 °C		73.5	73.5	22.5	66.1	17.9	58.8	14.1	51.4	11.0	44.1	8.36	36.7	6.24	29.4	4.51	22.0	3.10
33 °C		73.5	73.5	20.6	66.2	16.5	58.8	13.0	51.5	10.2	44.1	7.77	36.8	5.82	29.4	4.22	22.1	2.92
31 °C		73.5	73.5	19.0	66.2	15.3	58.8	12.1	51.5	9.44	44.1	7.24	36.8	5.44	29.4	3.96	22.1	2.74
30 °C		73.5	73.5	18.3	66.2	14.7	58.8	11.6	51.5	9.11	44.1	7.00	36.8	5.26	29.4	3.84	22.1	2.66
29 °C		73.5	73.5	17.6	66.2	14.1	58.8	11.2	51.5	8.79	44.1	6.77	36.8	5.10	29.4	3.72	22.1	2.58
27 °C		73.5	73.5	16.3	66.2	13.2	58.8	10.5	51.5	8.21	44.1	6.33	36.8	4.78	29.4	3.50	22.1	2.43
25 °C		73.5	73.5	15.2	66.2	12.3	58.8	9.76	51.5	7.67	44.1	5.93	36.8	4.49	29.4	3.29	22.1	2.30
23 °C		73.5	73.5	14.5	66.2	11.7	58.8	9.32	51.5	7.34	44.1	5.68	36.8	4.31	29.4	3.17	22.1	2.21
21 °C		73.5	73.5	14.1	66.2	11.4	58.8	9.12	51.5	7.19	44.1	5.58	36.8	4.24	29.4	3.12	22.1	2.18
20 °C		73.5	73.5	13.9	66.2	11.3	58.8	9.03	51.5	7.13	44.1	5.53	36.8	4.20	29.4	3.10	22.1	2.17
19 °C		73.5	73.5	13.8	66.2	11.2	58.8	8.95	51.5	7.06	44.1	5.49	36.8	4.17	29.4	3.08	22.1	2.15
17 °C		73.5	73.5	13.5	66.2	11.0	58.8	8.80	51.5	6.96	44.1	5.41	36.8	4.12	29.4	3.04	22.1	2.13
15 °C		73.5	73.5	13.3	66.2	10.8	58.8	8.67	51.5	6.86	44.1	5.34	36.8	4.07	29.4	3.01	22.1	2.11

TC : Total Capacity PI : Power Input
Indoor air temperature conditions : 27.0°C dry-bulb / 19.0°C wet bulb

Heating

Outdoor Unit Dry-Bulb (°C) / Wet-Bulb (°C)		Outdoor Unit 100% Heating Capacity (kW)	Compressor + Outdoor Fan Power consumption (kW)															
			100% Capacity		90% Capacity		80% Capacity		70% Capacity		60% Capacity		50% Capacity		40% Capacity		30% Capacity	
			TC (kW)	PI (kW)	TC (kW)	PI (kW)	TC (kW)	PI (kW)	TC (kW)	PI (kW)	TC (kW)	PI (kW)	TC (kW)	PI (kW)	TC (kW)	PI (kW)	TC (kW)	PI (kW)
15.0	13.7	73.5	73.5	15.6	66.2	13.0	58.8	10.8	51.5	8.96	44.1	7.42	36.8	6.08	29.4	4.87	22.1	3.70
13.0	11.8	73.5	73.5	16.4	66.2	13.5	58.8	11.2	51.5	9.25	44.1	7.63	36.8	6.23	29.4	4.98	22.1	3.78
11.0	9.8	73.5	73.5	17.2	66.2	14.2	58.8	11.7	51.5	9.59	44.1	7.87	36.8	6.41	29.4	5.11	22.1	3.87
9.0	7.9	73.5	73.5	18.2	66.2	14.9	58.8	12.2	51.5	9.94	44.1	8.12	36.8	6.58	29.4	5.23	22.1	3.97
7.0	6.0	73.5	73.5	19.2	66.2	15.6	58.8	12.7	51.5	10.3	44.1	8.39	36.8	6.77	29.4	5.37	22.1	4.06
5.0	4.1	71.0	71.0	19.1	63.9	15.5	56.8	12.6	49.7	10.3	42.6	8.33	35.5	6.73	28.4	5.33	21.3	4.04
3.0	2.2	68.5	68.5	18.9	61.7	15.4	54.8	12.5	48.0	10.2	41.1	8.28	34.3	6.68	27.4	5.30	20.6	4.01
0.0	-0.7	64.7	64.7	18.8	58.3	15.3	51.8	12.4	45.3	10.1	38.8	8.19	32.4	6.61	25.9	5.24	19.4	3.97
-3.0	-3.7	60.8	60.8	18.6	54.7	15.1	48.6	12.3	42.6	10.0	36.5	8.11	30.4	6.54	24.3	5.19	18.2	3.93
-5.0	-5.6	58.3	58.3	18.4	52.5	15.0	46.7	12.2	40.8	9.91	35.0	8.05	29.2	6.50	23.3	5.15	17.5	3.90
-7.0	-7.6	55.7	55.7	18.3	50.1	14.9	44.6	12.1	39.0	9.84	33.4	7.99	27.9	6.45	22.3	5.11	16.7	3.87
-10	-10.5	51.9	51.9	18.1	46.7	14.7	41.5	12.0	36.3	9.74	31.1	7.91	26.0	6.38	20.8	5.06	15.6	3.83
-14.5	-15.0	46.0	46.0	17.8	41.4	14.5	36.8	11.8	32.2	9.58	27.6	7.78	23.0	6.28	18.4	4.98	13.8	3.77

TC : Total Capacity PI : Power Input
Indoor air temperature conditions : 20.0°C dry-bulb



MMY-AP2816FT8P-E (28HP, 80.0kW system)

Cooling

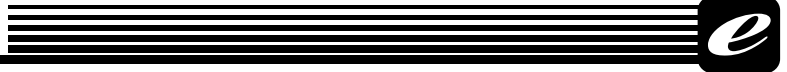
Outdoor Unit (°C)		Outdoor Unit 100% Capacity (kW)	Compressor + Outdoor Fan Power consumption (kW)															
			100%		90%		80%		70%		60%		50%		40%		30%	
			TC (kW)	PI (kW)	TC (kW)	PI (kW)	TC (kW)	PI (kW)	TC (kW)	PI (kW)	TC (kW)	PI (kW)	TC (kW)	PI (kW)	TC (kW)	PI (kW)	TC (kW)	PI (kW)
40 °C	74.5	74.5	27.4	67.0	21.9	59.6	17.3	52.1	13.4	44.7	10.2	37.2	7.62	29.8	5.51	22.3	3.79	
39 °C	75.6	75.6	27.0	68.1	21.6	60.5	17.0	53.0	13.2	45.4	10.1	37.8	7.51	30.3	5.43	22.7	3.74	
37 °C	77.9	77.9	26.2	70.1	20.9	62.3	16.5	54.5	12.8	46.7	9.77	39.0	7.28	31.2	5.27	23.4	3.62	
35 °C	80.0	80.0	25.4	72.0	20.3	64.0	16.0	56.0	12.4	48.0	9.46	40.0	7.05	32.0	5.10	24.0	3.51	
33 °C	80.0	80.0	23.3	72.0	18.7	64.0	14.8	56.0	11.5	48.0	8.79	40.0	6.58	32.0	4.78	24.0	3.30	
31 °C	80.0	80.0	21.5	72.0	17.3	64.0	13.7	56.0	10.7	48.0	8.19	40.0	6.15	32.0	4.48	24.0	3.10	
30 °C	80.0	80.0	20.7	72.0	16.6	64.0	13.2	56.0	10.3	48.0	7.92	40.0	5.95	32.0	4.34	24.0	3.01	
29 °C	80.0	80.0	19.9	72.0	16.0	64.0	12.7	56.0	9.95	48.0	7.65	40.0	5.76	32.0	4.21	24.0	2.92	
27 °C	80.0	80.0	18.5	72.0	14.9	64.0	11.8	56.0	9.28	48.0	7.16	40.0	5.41	32.0	3.96	24.0	2.75	
25 °C	80.0	80.0	17.2	72.0	13.9	64.0	11.0	56.0	8.68	48.0	6.71	40.0	5.08	32.0	3.72	24.0	2.60	
23 °C	80.0	80.0	16.4	72.0	13.2	64.0	10.5	56.0	8.30	48.0	6.43	40.0	4.87	32.0	3.58	24.0	2.50	
21 °C	80.0	80.0	16.0	72.0	12.9	64.0	10.3	56.0	8.13	48.0	6.31	40.0	4.79	32.0	3.53	24.0	2.47	
20 °C	80.0	80.0	15.8	72.0	12.8	64.0	10.2	56.0	8.06	48.0	6.26	40.0	4.75	32.0	3.50	24.0	2.45	
19 °C	80.0	80.0	15.6	72.0	12.6	64.0	10.1	56.0	7.99	48.0	6.21	40.0	4.72	32.0	3.48	24.0	2.44	
17 °C	80.0	80.0	15.3	72.0	12.4	64.0	9.95	56.0	7.87	48.0	6.12	40.0	4.66	32.0	3.44	24.0	2.41	
15 °C	80.0	80.0	15.1	72.0	12.2	64.0	9.81	56.0	7.76	48.0	6.04	40.0	4.60	32.0	3.40	24.0	2.39	

TC : Total Capacity PI : Power Input
Indoor air temperature conditions : 27.0°C dry-bulb / 19.0°C wet bulb

Heating

Outdoor Unit Dry-Bulb (°C) / Wet-Bulb (°C)		Outdoor Unit 100% Heating Capacity (kW)	Compressor + Outdoor Fan Power consumption (kW)															
			100% Capacity		90% Capacity		80% Capacity		70% Capacity		60% Capacity		50% Capacity		40% Capacity		30% Capacity	
			TC (kW)	PI (kW)	TC (kW)	PI (kW)	TC (kW)	PI (kW)	TC (kW)	PI (kW)	TC (kW)	PI (kW)	TC (kW)	PI (kW)	TC (kW)	PI (kW)	TC (kW)	PI (kW)
15.0	13.7	80.0	80.0	17.0	72.0	14.0	64.0	11.6	56.0	9.62	48.0	7.98	40.0	6.61	32.0	5.42	24.0	4.32
13.0	11.8	80.0	80.0	17.8	72.0	14.6	64.0	12.0	56.0	9.93	48.0	8.20	40.0	6.76	32.0	5.53	24.0	4.40
11.0	9.8	80.0	80.0	18.8	72.0	15.4	64.0	12.6	56.0	10.3	48.0	8.45	40.0	6.93	32.0	5.64	24.0	4.48
9.0	7.9	80.0	80.0	19.8	72.0	16.1	64.0	13.1	56.0	10.7	48.0	8.71	40.0	7.11	32.0	5.76	24.0	4.56
7.0	6.0	80.0	80.0	21.0	72.0	17.0	64.0	13.7	56.0	11.1	48.0	9.00	40.0	7.30	32.0	5.89	24.0	4.65
5.0	4.1	77.4	77.4	20.9	69.7	16.9	61.9	13.6	54.2	11.0	46.5	8.95	38.7	7.26	31.0	5.86	23.2	4.62
3.0	2.2	74.9	74.9	20.8	67.4	16.8	59.9	13.6	52.4	11.0	44.9	8.90	37.4	7.22	29.9	5.83	22.5	4.60
0.0	-0.7	70.9	70.9	20.6	63.8	16.6	56.7	13.4	49.6	10.9	42.6	8.82	35.5	7.16	28.4	5.78	21.3	4.56
-3.0	-3.7	66.9	66.9	20.4	60.2	16.5	53.5	13.3	46.8	10.8	40.1	8.74	33.4	7.09	26.7	5.72	20.1	4.52
-5.0	-5.6	64.3	64.3	20.3	57.9	16.4	51.4	13.2	45.0	10.7	38.6	8.69	32.1	7.05	25.7	5.69	19.3	4.49
-7.0	-7.6	61.6	61.6	20.1	55.4	16.3	49.3	13.2	43.1	10.6	36.9	8.63	30.8	7.01	24.6	5.65	18.5	4.46
-10	-10.5	57.7	57.7	20.0	51.9	16.1	46.1	13.0	40.4	10.5	34.6	8.55	28.8	6.94	23.1	5.60	17.3	4.42
-14.5	-15.0	51.6	51.6	19.7	46.4	15.9	41.3	12.9	36.1	10.4	30.9	8.43	25.8	6.84	20.6	5.52	15.5	4.36

TC : Total Capacity PI : Power Input
Indoor air temperature conditions : 20.0°C dry-bulb



MMY-AP3016FT8P-E (30HP, 85kW system)

Cooling

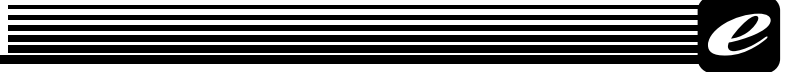
Outdoor Unit (°C)		Outdoor Unit 100% Capacity (kW)	Compressor + Outdoor Fan Power consumption (kW)															
			100%		90%		80%		70%		60%		50%		40%		30%	
			TC (kW)	PI (kW)	TC (kW)	PI (kW)	TC (kW)	PI (kW)	TC (kW)	PI (kW)	TC (kW)	PI (kW)	TC (kW)	PI (kW)	TC (kW)	PI (kW)	TC (kW)	PI (kW)
40 °C	79.1	79.1	28.7	71.2	22.8	63.3	17.8	55.4	13.8	47.5	10.4	39.6	7.71	31.6	5.53	23.7	3.78	
39 °C	80.4	80.4	28.3	72.3	22.4	64.3	17.6	56.3	13.6	48.2	10.3	40.2	7.60	32.2	5.45	24.1	3.72	
37 °C	82.8	82.8	27.4	74.5	21.8	66.2	17.0	57.9	13.2	49.7	9.94	41.4	7.37	33.1	5.29	24.8	3.61	
35 °C	85.0	85.0	26.6	76.5	21.1	68.0	16.5	59.5	12.7	51.0	9.63	42.5	7.14	34.0	5.12	25.5	3.49	
33 °C	85.0	85.0	24.3	76.5	19.4	68.0	15.2	59.5	11.8	51.0	8.94	42.5	6.65	34.0	4.79	25.5	3.28	
31 °C	85.0	85.0	22.4	76.5	17.9	68.0	14.1	59.5	10.9	51.0	8.32	42.5	6.21	34.0	4.49	25.5	3.08	
30 °C	85.0	85.0	21.6	76.5	17.2	68.0	13.6	59.5	10.6	51.0	8.04	42.5	6.01	34.0	4.35	25.5	2.99	
29 °C	85.0	85.0	20.7	76.5	16.6	68.0	13.1	59.5	10.2	51.0	7.77	42.5	5.82	34.0	4.21	25.5	2.90	
27 °C	85.0	85.0	19.2	76.5	15.4	68.0	12.2	59.5	9.51	51.0	7.27	42.5	5.45	34.0	3.96	25.5	2.74	
25 °C	85.0	85.0	17.9	76.5	14.3	68.0	11.4	59.5	8.88	51.0	6.80	42.5	5.12	34.0	3.72	25.5	2.58	
23 °C	85.0	85.0	17.0	76.5	13.7	68.0	10.8	59.5	8.49	51.0	6.51	42.5	4.91	34.0	3.58	25.5	2.48	
21 °C	85.0	85.0	16.6	76.5	13.3	68.0	10.6	59.5	8.31	51.0	6.39	42.5	4.82	34.0	3.52	25.5	2.45	
20 °C	85.0	85.0	16.4	76.5	13.2	68.0	10.5	59.5	8.23	51.0	6.33	42.5	4.79	34.0	3.50	25.5	2.43	
19 °C	85.0	85.0	16.2	76.5	13.1	68.0	10.4	59.5	8.16	51.0	6.28	42.5	4.75	34.0	3.48	25.5	2.42	
17 °C	85.0	85.0	15.9	76.5	12.8	68.0	10.2	59.5	8.03	51.0	6.19	42.5	4.69	34.0	3.43	25.5	2.39	
15 °C	85.0	85.0	15.6	76.5	12.6	68.0	10.1	59.5	7.92	51.0	6.11	42.5	4.63	34.0	3.40	25.5	2.37	

TC : Total Capacity PI : Power Input
Indoor air temperature conditions : 27.0°C dry-bulb / 19.0°C wet bulb

Heating

Outdoor Unit Dry-Bulb (°C) / Wet-Bulb (°C)		Outdoor Unit 100% Heating Capacity (kW)	Compressor + Outdoor Fan Power consumption (kW)															
			100% Capacity		90% Capacity		80% Capacity		70% Capacity		60% Capacity		50% Capacity		40% Capacity		30% Capacity	
			TC (kW)	PI (kW)	TC (kW)	PI (kW)	TC (kW)	PI (kW)	TC (kW)	PI (kW)	TC (kW)	PI (kW)	TC (kW)	PI (kW)	TC (kW)	PI (kW)	TC (kW)	PI (kW)
15.0	13.7	85.0	85.0	18.5	76.5	15.4	68.0	12.7	59.5	10.5	51.0	8.67	42.5	7.12	34.0	5.80	25.5	4.63
13.0	11.8	85.0	85.0	19.4	76.5	16.0	68.0	13.2	59.5	10.9	51.0	8.92	42.5	7.29	34.0	5.91	25.5	4.71
11.0	9.8	85.0	85.0	20.4	76.5	16.8	68.0	13.8	59.5	11.3	51.0	9.20	42.5	7.49	34.0	6.04	25.5	4.79
9.0	7.9	85.0	85.0	21.5	76.5	17.6	68.0	14.4	59.5	11.7	51.0	9.50	42.5	7.69	34.0	6.18	25.5	4.88
7.0	6.0	85.0	85.0	22.7	76.5	18.5	68.0	15.0	59.5	12.2	51.0	9.83	42.5	7.91	34.0	6.32	25.5	4.97
5.0	4.1	82.1	82.1	22.5	73.9	18.4	65.7	14.9	57.5	12.1	49.3	9.76	41.0	7.85	32.8	6.28	24.6	4.94
3.0	2.2	79.2	79.2	22.4	71.3	18.3	63.4	14.8	55.4	12.0	47.5	9.69	39.6	7.80	31.7	6.24	23.8	4.91
0.0	-0.7	74.8	74.8	22.2	67.3	18.1	59.8	14.7	52.3	11.9	44.9	9.59	37.4	7.72	29.9	6.17	22.4	4.85
-3.0	-3.7	70.2	70.2	21.9	63.2	17.9	56.2	14.5	49.1	11.7	42.1	9.49	35.1	7.64	28.1	6.10	21.1	4.80
-5.0	-5.6	67.3	67.3	21.8	60.6	17.7	53.8	14.4	47.1	11.7	40.4	9.42	33.7	7.58	26.9	6.06	20.2	4.77
-7.0	-7.6	64.3	64.3	21.6	57.8	17.6	51.4	14.3	45.0	11.6	38.6	9.35	32.1	7.53	25.7	6.02	19.3	4.73
-10	-10.5	59.8	59.8	21.4	53.9	17.4	47.9	14.2	41.9	11.5	35.9	9.25	29.9	7.45	23.9	5.95	18.0	4.68
-14.5	-15.0	53.0	53.0	21.0	47.7	17.1	42.4	13.9	37.1	11.3	31.8	9.09	26.5	7.32	21.2	5.85	15.9	4.60

TC : Total Capacity PI : Power Input
Indoor air temperature conditions : 20.0°C dry-bulb



MMY-AP3216FT8P-E (32HP, 90.4kW system)

Cooling

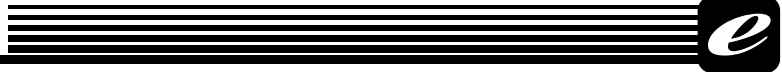
Outdoor Unit (°C)		Outdoor Unit 100% Capacity (kW)	Compressor + Outdoor Fan Power consumption (kW)															
			100%		90%		80%		70%		60%		50%		40%		30%	
			TC (kW)	PI (kW)	TC (kW)	PI (kW)	TC (kW)	PI (kW)	TC (kW)	PI (kW)	TC (kW)	PI (kW)	TC (kW)	PI (kW)	TC (kW)	PI (kW)	TC (kW)	PI (kW)
40 °C	84.1	84.1	31.0	75.7	24.2	67.3	18.6	58.9	14.1	50.5	10.6	42.1	7.82	33.7	5.73	25.2	4.18	
39 °C	85.5	85.5	30.5	76.9	23.9	68.4	18.4	59.8	13.9	51.3	10.4	42.7	7.71	34.2	5.65	25.6	4.12	
37 °C	88.0	88.0	29.6	79.2	23.1	70.4	17.8	61.6	13.5	52.8	10.1	44.0	7.47	35.2	5.48	26.4	3.99	
35 °C	90.4	90.4	28.7	81.4	22.4	72.3	17.2	63.3	13.1	54.2	9.8	45.2	7.24	36.2	5.31	27.1	3.86	
33 °C	90.4	90.4	26.2	81.4	20.5	72.3	15.9	63.3	12.1	54.2	9.08	45.2	6.75	36.2	4.98	27.1	3.65	
31 °C	90.4	90.4	24.1	81.4	18.9	72.3	14.6	63.3	11.2	54.2	8.45	45.2	6.32	36.2	4.69	27.1	3.46	
30 °C	90.4	90.4	23.1	81.4	18.2	72.3	14.1	63.3	10.8	54.2	8.16	45.2	6.11	36.2	4.55	27.1	3.37	
29 °C	90.4	90.4	22.2	81.4	17.5	72.3	13.6	63.3	10.4	54.2	7.88	45.2	5.92	36.2	4.42	27.1	3.28	
27 °C	90.4	90.4	20.5	81.4	16.2	72.3	12.6	63.3	9.68	54.2	7.37	45.2	5.56	36.2	4.16	27.1	3.10	
25 °C	90.4	90.4	19.0	81.4	15.0	72.3	11.7	63.3	9.04	54.2	6.90	45.2	5.22	36.2	3.93	27.1	2.94	
23 °C	90.4	90.4	18.1	81.4	14.3	72.3	11.2	63.3	8.63	54.2	6.61	45.2	5.02	36.2	3.79	27.1	2.84	
21 °C	90.4	90.4	17.6	81.4	13.9	72.3	10.9	63.3	8.45	54.2	6.48	45.2	4.93	36.2	3.74	27.1	2.82	
20 °C	90.4	90.4	17.4	81.4	13.8	72.3	10.8	63.3	8.36	54.2	6.42	45.2	4.90	36.2	3.71	27.1	2.80	
19 °C	90.4	90.4	17.2	81.4	13.6	72.3	10.7	63.3	8.29	54.2	6.37	45.2	4.86	36.2	3.69	27.1	2.79	
17 °C	90.4	90.4	16.8	81.4	13.3	72.3	10.5	63.3	8.15	54.2	6.28	45.2	4.80	36.2	3.66	27.1	2.77	
15 °C	90.4	90.4	16.5	81.4	13.1	72.3	10.3	63.3	8.04	54.2	6.20	45.2	4.75	36.2	3.62	27.1	2.75	

TC : Total Capacity PI : Power Input
Indoor air temperature conditions : 27.0°C dry-bulb / 19.0°C wet bulb

Heating

Outdoor Unit Dry-Bulb (°C) / Wet-Bulb (°C)		Outdoor Unit 100% Heating Capacity (kW)	Compressor + Outdoor Fan Power consumption (kW)															
			100% Capacity		90% Capacity		80% Capacity		70% Capacity		60% Capacity		50% Capacity		40% Capacity		30% Capacity	
			TC (kW)	PI (kW)	TC (kW)	PI (kW)	TC (kW)	PI (kW)	TC (kW)	PI (kW)	TC (kW)	PI (kW)	TC (kW)	PI (kW)	TC (kW)	PI (kW)	TC (kW)	PI (kW)
15.0	13.7	90.4	90.4	19.9	81.4	16.6	72.3	13.9	63.3	11.5	54.2	9.52	45.2	7.78	36.2	6.21	27.1	4.74
13.0	11.8	90.4	90.4	20.8	81.4	17.3	72.3	14.4	63.3	11.9	54.2	9.80	45.2	7.97	36.2	6.35	27.1	4.84
11.0	9.8	90.4	90.4	21.8	81.4	18.1	72.3	15.0	63.3	12.3	54.2	10.1	45.2	8.20	36.2	6.51	27.1	4.96
9.0	7.9	90.4	90.4	23.0	81.4	19.0	72.3	15.6	63.3	12.8	54.2	10.4	45.2	8.43	36.2	6.67	27.1	5.07
7.0	6.0	90.4	90.4	24.4	81.4	19.9	72.3	16.3	63.3	13.3	54.2	10.8	45.2	8.68	36.2	6.85	27.1	5.19
5.0	4.1	87.5	87.5	24.1	78.7	19.8	70.0	16.2	61.2	13.2	52.5	10.7	43.7	8.63	35.0	6.81	26.2	5.16
3.0	2.2	84.6	84.6	23.9	76.1	19.6	67.7	16.1	59.2	13.1	50.7	10.7	42.3	8.58	33.8	6.77	25.4	5.13
0.0	-0.7	80.1	80.1	23.7	72.1	19.5	64.1	15.9	56.1	13.0	48.1	10.6	40.1	8.50	32.1	6.71	24.0	5.09
-3.0	-3.7	75.6	75.6	23.5	68.0	19.3	60.4	15.8	52.9	12.9	45.3	10.5	37.8	8.42	30.2	6.65	22.7	5.04
-5.0	-5.6	72.6	72.6	23.3	65.4	19.2	58.1	15.7	50.9	12.8	43.6	10.4	36.3	8.37	29.1	6.61	21.8	5.01
-7.0	-7.6	69.6	69.6	23.2	62.6	19.1	55.7	15.6	48.7	12.7	41.8	10.3	34.8	8.32	27.8	6.57	20.9	4.98
-10	-10.5	65.2	65.2	23.0	58.6	18.9	52.1	15.5	45.6	12.6	39.1	10.2	32.6	8.25	26.1	6.51	19.5	4.93
-14.5	-15.0	58.3	58.3	22.7	52.4	18.6	46.6	15.2	40.8	12.4	35.0	10.1	29.1	8.13	23.3	6.42	17.5	4.86

TC : Total Capacity PI : Power Input
Indoor air temperature conditions : 20.0°C dry-bulb



MMY-AP3416FT8P-E (34HP, 95.4kW system)

Cooling

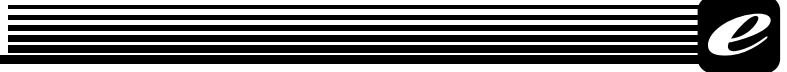
Outdoor Unit (°C)		Outdoor Unit 100% Capacity (kW)	Compressor + Outdoor Fan Power consumption (kW)															
			100%		90%		80%		70%		60%		50%		40%		30%	
			TC (kW)	PI (kW)	TC (kW)	PI (kW)	TC (kW)	PI (kW)	TC (kW)	PI (kW)	TC (kW)	PI (kW)	TC (kW)	PI (kW)	TC (kW)	PI (kW)	TC (kW)	PI (kW)
40 °C	88.8	88.8	32.3	79.9	25.1	71.0	19.2	62.1	14.5	53.3	10.8	44.4	7.91	35.5	5.75	26.6	4.16	
39 °C	90.2	90.2	31.8	81.2	24.8	72.2	19.0	63.1	14.3	54.1	10.6	45.1	7.80	36.1	5.67	27.1	4.10	
37 °C	92.9	92.9	30.9	83.6	24.0	74.3	18.4	65.0	13.9	55.7	10.3	46.5	7.56	37.2	5.50	27.9	3.97	
35 °C	95.4	95.4	29.9	85.8	23.2	76.3	17.8	66.8	13.4	57.2	10.0	47.7	7.32	38.2	5.32	28.6	3.85	
33 °C	95.4	95.4	27.3	85.9	21.3	76.3	16.4	66.8	12.4	57.2	9.24	47.7	6.82	38.2	4.99	28.6	3.64	
31 °C	95.4	95.4	25.0	85.9	19.6	76.3	15.1	66.8	11.5	57.2	8.59	47.7	6.38	38.2	4.70	28.6	3.44	
30 °C	95.4	95.4	24.0	85.9	18.8	76.3	14.5	66.8	11.0	57.2	8.30	47.7	6.17	38.2	4.56	28.6	3.35	
29 °C	95.4	95.4	23.1	85.9	18.1	76.3	14.0	66.8	10.6	57.2	8.01	47.7	5.97	38.2	4.42	28.6	3.26	
27 °C	95.4	95.4	21.3	85.9	16.7	76.3	13.0	66.8	9.91	57.2	7.49	47.7	5.60	38.2	4.17	28.6	3.09	
25 °C	95.4	95.4	19.7	85.9	15.5	76.3	12.0	66.8	9.24	57.2	7.00	47.7	5.26	38.2	3.93	28.6	2.92	
23 °C	95.4	95.4	18.7	85.9	14.8	76.3	11.5	66.8	8.82	57.2	6.70	47.7	5.05	38.2	3.79	28.6	2.83	
21 °C	95.4	95.4	18.2	85.9	14.4	76.3	11.2	66.8	8.62	57.2	6.57	47.7	4.97	38.2	3.74	28.6	2.80	
20 °C	95.4	95.4	18.0	85.9	14.2	76.3	11.1	66.8	8.54	57.2	6.51	47.7	4.93	38.2	3.71	28.6	2.78	
19 °C	95.4	95.4	17.8	85.9	14.0	76.3	11.0	66.8	8.46	57.2	6.46	47.7	4.90	38.2	3.69	28.6	2.77	
17 °C	95.4	95.4	17.4	85.9	13.8	76.3	10.8	66.8	8.32	57.2	6.36	47.7	4.83	38.2	3.65	28.6	2.75	
15 °C	95.4	95.4	17.1	85.9	13.5	76.3	10.6	66.8	8.19	57.2	6.28	47.7	4.78	38.2	3.62	28.6	2.73	

TC : Total Capacity PI : Power Input
Indoor air temperature conditions : 27.0°C dry-bulb / 19.0°C wet bulb

Heating

Outdoor Unit Dry-Bulb (°C) / Wet-Bulb (°C)		Outdoor Unit 100% Heating Capacity (kW)	Compressor + Outdoor Fan Power consumption (kW)															
			100% Capacity		90% Capacity		80% Capacity		70% Capacity		60% Capacity		50% Capacity		40% Capacity		30% Capacity	
			TC (kW)	PI (kW)	TC (kW)	PI (kW)	TC (kW)	PI (kW)	TC (kW)	PI (kW)	TC (kW)	PI (kW)	TC (kW)	PI (kW)	TC (kW)	PI (kW)	TC (kW)	PI (kW)
15.0	13.7	95.4	95.4	21.4	85.9	18.0	76.3	15.0	66.8	12.4	57.2	10.2	47.7	8.28	38.2	6.58	28.6	5.05
13.0	11.8	95.4	95.4	22.4	85.9	18.7	76.3	15.6	66.8	12.8	57.2	10.5	47.7	8.50	38.2	6.74	28.6	5.15
11.0	9.8	95.4	95.4	23.5	85.9	19.6	76.3	16.2	66.8	13.3	57.2	10.9	47.7	8.75	38.2	6.91	28.6	5.27
9.0	7.9	95.4	95.4	24.6	85.9	20.4	76.3	16.9	66.8	13.8	57.2	11.2	47.7	9.01	38.2	7.09	28.6	5.39
7.0	6.0	95.4	95.4	25.9	85.9	21.4	76.3	17.6	66.8	14.4	57.2	11.6	47.7	9.28	38.2	7.28	28.6	5.51
5.0	4.1	92.2	92.2	25.7	82.9	21.3	73.7	17.5	64.5	14.3	55.3	11.5	46.1	9.22	36.9	7.23	27.6	5.48
3.0	2.2	88.9	88.9	25.6	80.0	21.1	71.1	17.4	62.3	14.2	53.4	11.5	44.5	9.16	35.6	7.18	26.7	5.44
0.0	-0.7	84.0	84.0	25.3	75.6	20.9	67.2	17.2	58.8	14.0	50.4	11.3	42.0	9.06	33.6	7.11	25.2	5.38
-3.0	-3.7	78.9	78.9	25.0	71.0	20.7	63.1	17.0	55.2	13.9	47.3	11.2	39.4	8.97	31.6	7.03	23.7	5.33
-5.0	-5.6	75.7	75.7	24.9	68.1	20.5	60.5	16.9	53.0	13.8	45.4	11.1	37.8	8.91	30.3	6.98	22.7	5.29
-7.0	-7.6	72.3	72.3	24.7	65.0	20.4	57.8	16.8	50.6	13.7	43.4	11.1	36.1	8.84	28.9	6.93	21.7	5.25
-10	-10.5	67.3	67.3	24.4	60.6	20.2	53.9	16.6	47.1	13.5	40.4	10.9	33.7	8.75	26.9	6.86	20.2	5.20
-14.5	-15.0	59.7	59.7	24.0	53.7	19.8	47.7	16.3	41.8	13.3	35.8	10.8	29.8	8.61	23.9	6.75	17.9	5.11

TC : Total Capacity PI : Power Input
Indoor air temperature conditions : 20.0°C dry-bulb



MMY-AP3616FT8P-E (36HP, 100.8kW system)

Cooling

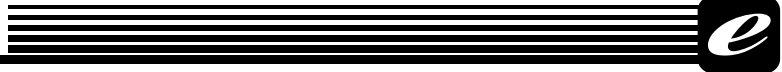
Outdoor Unit (°C)		Outdoor Unit 100% Capacity (kW)	Compressor + Outdoor Fan Power consumption (kW)															
			100%		90%		80%		70%		60%		50%		40%		30%	
			TC (kW)	PI (kW)	TC (kW)	PI (kW)	TC (kW)	PI (kW)	TC (kW)	PI (kW)	TC (kW)	PI (kW)	TC (kW)	PI (kW)	TC (kW)	PI (kW)	TC (kW)	PI (kW)
40 °C	93.8	93.8	34.6	84.4	26.5	75.0	20.0	65.7	14.9	56.3	10.9	46.9	8.02	37.5	5.96	28.1	4.56	
39 °C	95.3	95.3	34.1	85.8	26.1	76.3	19.7	66.7	14.6	57.2	10.8	47.7	7.90	38.1	5.87	28.6	4.49	
37 °C	98.2	98.2	33.0	88.3	25.3	78.5	19.1	68.7	14.2	58.9	10.4	49.1	7.66	39.3	5.69	29.4	4.36	
35 °C	100.8	100.8	32.0	90.7	24.5	80.6	18.5	70.6	13.8	60.5	10.1	50.4	7.42	40.3	5.51	30.2	4.22	
33 °C	100.8	100.8	29.1	90.7	22.4	80.6	16.9	70.6	12.7	60.5	9.37	50.4	6.92	40.3	5.19	30.2	4.01	
31 °C	100.8	100.8	26.6	90.7	20.5	80.6	15.6	70.6	11.7	60.5	8.70	50.4	6.48	40.3	4.90	30.2	3.82	
30 °C	100.8	100.8	25.5	90.7	19.7	80.6	15.0	70.6	11.3	60.5	8.40	50.4	6.27	40.3	4.76	30.2	3.72	
29 °C	100.8	100.8	24.5	90.7	18.9	80.6	14.4	70.6	10.8	60.5	8.11	50.4	6.08	40.3	4.62	30.2	3.63	
27 °C	100.8	100.8	22.6	90.7	17.5	80.6	13.3	70.6	10.1	60.5	7.57	50.4	5.71	40.3	4.37	30.2	3.45	
25 °C	100.8	100.8	20.9	90.7	16.2	80.6	12.4	70.6	9.39	60.5	7.09	50.4	5.37	40.3	4.13	30.2	3.28	
23 °C	100.8	100.8	19.8	90.7	15.3	80.6	11.8	70.6	8.96	60.5	6.78	50.4	5.16	40.3	3.99	30.2	3.19	
21 °C	100.8	100.8	19.2	90.7	14.9	80.6	11.5	70.6	8.76	60.5	6.65	50.4	5.08	40.3	3.95	30.2	3.16	
20 °C	100.8	100.8	18.9	90.7	14.7	80.6	11.4	70.6	8.67	60.5	6.59	50.4	5.04	40.3	3.93	30.2	3.15	
19 °C	100.8	100.8	18.7	90.7	14.6	80.6	11.2	70.6	8.58	60.5	6.54	50.4	5.01	40.3	3.91	30.2	3.15	
17 °C	100.8	100.8	18.3	90.7	14.3	80.6	11.0	70.6	8.44	60.5	6.44	50.4	4.95	40.3	3.88	30.2	3.13	
15 °C	100.8	100.8	17.9	90.7	14.0	80.6	10.8	70.6	8.31	60.5	6.36	50.4	4.90	40.3	3.85	30.2	3.11	

TC : Total Capacity PI : Power Input
Indoor air temperature conditions : 27.0°C dry-bulb / 19.0°C wet bulb

Heating

Outdoor Unit Dry-Bulb (°C) / Wet-Bulb (°C)		Outdoor Unit 100% Heating Capacity (kW)	Compressor + Outdoor Fan Power consumption (kW)															
			100% Capacity		90% Capacity		80% Capacity		70% Capacity		60% Capacity		50% Capacity		40% Capacity		30% Capacity	
			TC (kW)	PI (kW)	TC (kW)	PI (kW)	TC (kW)	PI (kW)	TC (kW)	PI (kW)	TC (kW)	PI (kW)	TC (kW)	PI (kW)	TC (kW)	PI (kW)	TC (kW)	PI (kW)
15.0	13.7	100.8	100.8	22.8	90.7	19.2	80.6	16.1	70.6	13.4	60.5	11.1	50.4	8.94	40.3	7.00	30.2	5.16
13.0	11.8	100.8	100.8	23.8	90.7	20.0	80.6	16.7	70.6	13.9	60.5	11.4	50.4	9.19	40.3	7.18	30.2	5.29
11.0	9.8	100.8	100.8	24.9	90.7	20.9	80.6	17.4	70.6	14.4	60.5	11.8	50.4	9.46	40.3	7.38	30.2	5.43
9.0	7.9	100.8	100.8	26.1	90.7	21.8	80.6	18.1	70.6	14.9	60.5	12.2	50.4	9.75	40.3	7.58	30.2	5.58
7.0	6.0	100.8	100.8	27.4	90.7	22.8	80.6	18.8	70.6	15.5	60.5	12.6	50.4	10.0	40.3	7.80	30.2	5.73
5.0	4.1	97.6	97.6	27.2	87.8	22.6	78.0	18.7	68.3	15.4	58.5	12.5	48.8	10.0	39.0	7.76	29.3	5.70
3.0	2.2	94.3	94.3	27.1	84.9	22.5	75.4	18.6	66.0	15.3	56.6	12.4	47.2	9.93	37.7	7.71	28.3	5.67
0.0	-0.7	89.4	89.4	26.8	80.4	22.3	71.5	18.5	62.6	15.2	53.6	12.3	44.7	9.85	35.7	7.65	26.8	5.62
-3.0	-3.7	84.2	84.2	26.6	75.8	22.1	67.4	18.3	59.0	15.0	50.5	12.2	42.1	9.76	33.7	7.58	25.3	5.56
-5.0	-5.6	81.0	81.0	26.4	72.9	22.0	64.8	18.2	56.7	14.9	48.6	12.1	40.5	9.70	32.4	7.53	24.3	5.53
-7.0	-7.6	77.6	77.6	26.3	69.8	21.8	62.1	18.1	54.3	14.8	46.6	12.1	38.8	9.64	31.0	7.48	23.3	5.50
-10	-10.5	72.6	72.6	26.0	65.4	21.6	58.1	17.9	50.9	14.7	43.6	11.9	36.3	9.55	29.1	7.42	21.8	5.45
-14.5	-15.0	65.0	65.0	25.7	58.5	21.3	52.0	17.6	45.5	14.5	39.0	11.8	32.5	9.42	26.0	7.31	19.5	5.37

TC : Total Capacity PI : Power Input
Indoor air temperature conditions : 20.0°C dry-bulb



MMY-AP3816FT8P-E (38HP, 106.4kW system)

Cooling

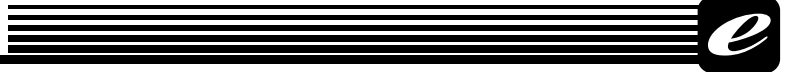
Outdoor Unit (°C)		Outdoor Unit 100% Capacity (kW)	Compressor + Outdoor Fan Power consumption (kW)															
			100%		90%		80%		70%		60%		50%		40%		30%	
			TC (kW)	PI (kW)	TC (kW)	PI (kW)	TC (kW)	PI (kW)	TC (kW)	PI (kW)	TC (kW)	PI (kW)	TC (kW)	PI (kW)	TC (kW)	PI (kW)	TC (kW)	PI (kW)
40 °C	99.0	99.0	37.4	89.1	29.4	79.2	22.9	69.3	17.6	59.4	13.3	49.5	10.0	39.6	7.25	29.7	5.07	
39 °C	100.6	100.6	36.8	90.6	29.0	80.5	22.6	70.4	17.3	60.4	13.1	50.3	9.81	40.2	7.14	30.2	4.99	
37 °C	103.6	103.6	35.7	93.3	28.1	82.9	21.9	72.5	16.8	62.2	12.8	51.8	9.51	41.4	6.93	31.1	4.84	
35 °C	106.4	106.4	34.6	95.7	27.2	85.1	21.2	74.5	16.3	63.8	12.3	53.2	9.21	42.6	6.71	31.9	4.69	
33 °C	106.4	106.4	31.7	95.8	25.0	85.1	19.5	74.5	15.1	63.8	11.5	53.2	8.59	42.6	6.29	31.9	4.41	
31 °C	106.4	106.4	29.1	95.8	23.1	85.1	18.1	74.5	14.0	63.8	10.7	53.2	8.04	42.6	5.90	31.9	4.15	
30 °C	106.4	106.4	28.0	95.8	22.2	85.1	17.4	74.5	13.5	63.8	10.3	53.2	7.78	42.6	5.72	31.9	4.03	
29 °C	106.4	106.4	26.9	95.8	21.4	85.1	16.8	74.5	13.0	63.8	10.0	53.2	7.53	42.6	5.55	31.9	3.91	
27 °C	106.4	106.4	24.9	95.8	19.8	85.1	15.6	74.5	12.1	63.8	9.34	53.2	7.07	42.6	5.23	31.9	3.69	
25 °C	106.4	106.4	23.1	95.8	18.4	85.1	14.5	74.5	11.4	63.8	8.75	53.2	6.64	42.6	4.92	31.9	3.48	
23 °C	106.4	106.4	22.0	95.8	17.5	85.1	13.9	74.5	10.9	63.8	8.39	53.2	6.38	42.6	4.74	31.9	3.36	
21 °C	106.4	106.4	21.4	95.8	17.1	85.1	13.6	74.5	10.6	63.8	8.23	53.2	6.27	42.6	4.67	31.9	3.31	
20 °C	106.4	106.4	21.2	95.8	16.9	85.1	13.4	74.5	10.5	63.8	8.16	53.2	6.23	42.6	4.63	31.9	3.29	
19 °C	106.4	106.4	20.9	95.8	16.8	85.1	13.3	74.5	10.4	63.8	8.10	53.2	6.18	42.6	4.61	31.9	3.28	
17 °C	106.4	106.4	20.5	95.8	16.5	85.1	13.1	74.5	10.3	63.8	7.98	53.2	6.10	42.6	4.55	31.9	3.24	
15 °C	106.4	106.4	20.2	95.8	16.2	85.1	12.9	74.5	10.1	63.8	7.88	53.2	6.04	42.6	4.51	31.9	3.21	

TC : Total Capacity PI : Power Input
Indoor air temperature conditions : 27.0°C dry-bulb / 19.0°C wet bulb

Heating

Outdoor Unit Dry-Bulb (°C) / Wet-Bulb (°C)		Outdoor Unit 100% Heating Capacity (kW)	Compressor + Outdoor Fan Power consumption (kW)															
			100% Capacity		90% Capacity		80% Capacity		70% Capacity		60% Capacity		50% Capacity		40% Capacity		30% Capacity	
			TC (kW)	PI (kW)	TC (kW)	PI (kW)	TC (kW)	PI (kW)	TC (kW)	PI (kW)	TC (kW)	PI (kW)	TC (kW)	PI (kW)	TC (kW)	PI (kW)	TC (kW)	PI (kW)
15.0	13.7	106.4	106.4	24.7	95.8	20.9	85.1	17.5	74.5	14.6	63.8	12.0	53.2	9.65	42.6	7.48	31.9	5.41
13.0	11.8	106.4	106.4	25.8	95.8	21.7	85.1	18.1	74.5	15.1	63.8	12.4	53.2	9.93	42.6	7.69	31.9	5.56
11.0	9.8	106.4	106.4	27.0	95.8	22.6	85.1	18.9	74.5	15.6	63.8	12.8	53.2	10.2	42.6	7.92	31.9	5.72
9.0	7.9	106.4	106.4	28.2	95.8	23.6	85.1	19.6	74.5	16.2	63.8	13.2	53.2	10.5	42.6	8.15	31.9	5.89
7.0	6.0	106.4	106.4	29.6	95.8	24.7	85.1	20.4	74.5	16.8	63.8	13.6	53.2	10.9	42.6	8.39	31.9	6.07
5.0	4.1	102.8	102.8	29.4	92.5	24.5	82.2	20.3	71.9	16.7	61.7	13.5	51.4	10.8	41.1	8.34	30.8	6.03
3.0	2.2	99.1	99.1	29.2	89.2	24.3	79.3	20.2	69.4	16.6	59.5	13.5	49.6	10.7	39.7	8.28	29.7	5.98
0.0	-0.7	93.6	93.6	28.9	84.2	24.1	74.9	19.9	65.5	16.4	56.2	13.3	46.8	10.6	37.4	8.19	28.1	5.92
-3.0	-3.7	87.9	87.9	28.6	79.1	23.8	70.3	19.7	61.5	16.2	52.7	13.2	43.9	10.5	35.2	8.10	26.4	5.86
-5.0	-5.6	84.3	84.3	28.4	75.8	23.7	67.4	19.6	59.0	16.1	50.6	13.1	42.1	10.4	33.7	8.05	25.3	5.82
-7.0	-7.6	80.4	80.4	28.2	72.4	23.5	64.4	19.4	56.3	16.0	48.3	13.0	40.2	10.4	32.2	7.99	24.1	5.77
-10	-10.5	74.9	74.9	27.9	67.4	23.2	59.9	19.2	52.4	15.8	44.9	12.8	37.5	10.2	30.0	7.90	22.5	5.71
-14.5	-15.0	66.3	66.3	27.4	59.7	22.8	53.1	18.9	46.4	15.5	39.8	12.6	33.2	10.1	26.5	7.77	19.9	5.62

TC : Total Capacity PI : Power Input
Indoor air temperature conditions : 20.0°C dry-bulb



MMY-AP4016FT8P-E (40HP, 112kW system)

Cooling

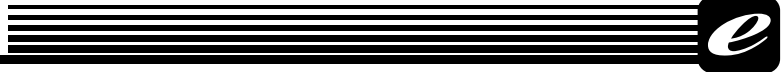
Outdoor Unit (°C)		Outdoor Unit 100% Capacity (kW)	Compressor + Outdoor Fan Power consumption (kW)															
			100%		90%		80%		70%		60%		50%		40%		30%	
			TC (kW)	PI (kW)	TC (kW)	PI (kW)	TC (kW)	PI (kW)	TC (kW)	PI (kW)	TC (kW)	PI (kW)	TC (kW)	PI (kW)	TC (kW)	PI (kW)	TC (kW)	PI (kW)
40 °C		104.2	104.2	40.2	93.8	32.4	83.4	25.8	73.0	20.4	62.5	15.8	52.1	11.9	41.7	8.55	31.3	5.57
39 °C		105.9	105.9	39.6	95.3	31.9	84.7	25.5	74.1	20.0	63.5	15.5	53.0	11.7	42.4	8.42	31.8	5.49
37 °C		109.1	109.1	38.4	98.2	30.9	87.3	24.7	76.3	19.4	65.4	15.1	54.5	11.4	43.6	8.17	32.7	5.32
35 °C		112.0	112.0	37.2	100.8	30.0	89.6	23.9	78.4	18.8	67.2	14.6	56.0	11.0	44.8	7.91	33.6	5.15
33 °C		112.0	112.0	34.2	100.8	27.7	89.6	22.1	78.4	17.5	67.2	13.6	56.0	10.3	44.8	7.39	33.6	4.81
31 °C		112.0	112.0	31.6	100.8	25.6	89.6	20.6	78.4	16.3	67.2	12.7	56.0	9.60	44.8	6.91	33.6	4.49
30 °C		112.0	112.0	30.4	100.8	24.7	89.6	19.8	78.4	15.7	67.2	12.3	56.0	9.29	44.8	6.69	33.6	4.34
29 °C		112.0	112.0	29.3	100.8	23.8	89.6	19.1	78.4	15.2	67.2	11.9	56.0	8.99	44.8	6.48	33.6	4.20
27 °C		112.0	112.0	27.2	100.8	22.2	89.6	17.9	78.4	14.2	67.2	11.1	56.0	8.44	44.8	6.08	33.6	3.93
25 °C		112.0	112.0	25.4	100.8	20.7	89.6	16.7	78.4	13.3	67.2	10.4	56.0	7.92	44.8	5.71	33.6	3.69
23 °C		112.0	112.0	24.2	100.8	19.7	89.6	16.0	78.4	12.7	67.2	9.99	56.0	7.60	44.8	5.48	33.6	3.53
21 °C		112.0	112.0	23.6	100.8	19.3	89.6	15.6	78.4	12.5	67.2	9.81	56.0	7.47	44.8	5.38	33.6	3.46
20 °C		112.0	112.0	23.4	100.8	19.1	89.6	15.5	78.4	12.4	67.2	9.73	56.0	7.41	44.8	5.34	33.6	3.43
19 °C		112.0	112.0	23.1	100.8	18.9	89.6	15.4	78.4	12.3	67.2	9.66	56.0	7.35	44.8	5.30	33.6	3.41
17 °C		112.0	112.0	22.7	100.8	18.6	89.6	15.1	78.4	12.1	67.2	9.52	56.0	7.26	44.8	5.23	33.6	3.36
15 °C		112.0	112.0	22.4	100.8	18.4	89.6	14.9	78.4	12.0	67.2	9.41	56.0	7.17	44.8	5.17	33.6	3.31

TC : Total Capacity PI : Power Input
Indoor air temperature conditions : 27.0°C dry-bulb / 19.0°C wet bulb

Heating

Outdoor Unit Dry-Bulb (°C) / Wet-Bulb (°C)		Outdoor Unit 100% Heating Capacity (kW)	Compressor + Outdoor Fan Power consumption (kW)															
			100% Capacity		90% Capacity		80% Capacity		70% Capacity		60% Capacity		50% Capacity		40% Capacity		30% Capacity	
			TC (kW)	PI (kW)	TC (kW)	PI (kW)	TC (kW)	PI (kW)	TC (kW)	PI (kW)	TC (kW)	PI (kW)	TC (kW)	PI (kW)	TC (kW)	PI (kW)	TC (kW)	PI (kW)
15.0	13.7	112.0	112.0	26.6	100.8	22.5	89.6	18.9	78.4	15.7	67.2	12.9	56.0	10.4	44.8	7.97	33.6	5.66
13.0	11.8	112.0	112.0	27.7	100.8	23.4	89.6	19.6	78.4	16.3	67.2	13.3	56.0	10.7	44.8	8.20	33.6	5.83
11.0	9.8	112.0	112.0	29.0	100.8	24.4	89.6	20.3	78.4	16.8	67.2	13.8	56.0	11.0	44.8	8.45	33.6	6.01
9.0	7.9	112.0	112.0	30.4	100.8	25.4	89.6	21.1	78.4	17.4	67.2	14.2	56.0	11.3	44.8	8.71	33.6	6.20
7.0	6.0	112.0	112.0	31.8	100.8	26.6	89.6	22.0	78.4	18.1	67.2	14.7	56.0	11.7	44.8	8.98	33.6	6.40
5.0	4.1	108.0	108.0	31.7	97.2	26.4	86.4	21.9	75.6	18.0	64.8	14.6	54.0	11.6	43.2	8.91	32.4	6.35
3.0	2.2	104.0	104.0	31.4	93.6	26.2	83.2	21.7	72.8	17.8	62.4	14.5	52.0	11.5	41.6	8.84	31.2	6.30
0.0	-0.7	97.9	97.9	31.0	88.1	25.9	78.3	21.4	68.5	17.6	58.7	14.3	48.9	11.4	39.1	8.74	29.4	6.23
-3.0	-3.7	91.5	91.5	30.7	82.4	25.5	73.2	21.2	64.1	17.4	54.9	14.1	45.8	11.3	36.6	8.63	27.5	6.15
-5.0	-5.6	87.5	87.5	30.4	78.8	25.3	70.0	21.0	61.3	17.3	52.5	14.0	43.8	11.2	35.0	8.56	26.3	6.10
-7.0	-7.6	83.3	83.3	30.2	75.0	25.1	66.6	20.8	58.3	17.1	50.0	13.9	41.6	11.1	33.3	8.49	25.0	6.05
-10	-10.5	77.2	77.2	29.8	69.5	24.8	61.7	20.6	54.0	16.9	46.3	13.7	38.6	10.9	30.9	8.39	23.2	5.98
-14.5	-15.0	67.7	67.7	29.2	60.9	24.3	54.1	20.2	47.4	16.6	40.6	13.5	33.8	10.7	27.1	8.23	20.3	5.86

TC : Total Capacity PI : Power Input
Indoor air temperature conditions : 20.0°C dry-bulb



MMY-AP4216FT8P-E (42HP, 120kW system)

Cooling

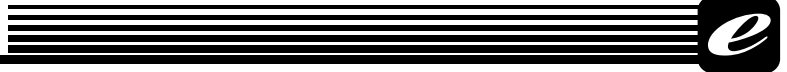
Outdoor Unit (°C)		Outdoor Unit 100% Capacity (kW)	Compressor + Outdoor Fan Power consumption (kW)															
			100%		90%		80%		70%		60%		50%		40%		30%	
			TC (kW)	PI (kW)	TC (kW)	PI (kW)	TC (kW)	PI (kW)	TC (kW)	PI (kW)	TC (kW)	PI (kW)	TC (kW)	PI (kW)	TC (kW)	PI (kW)	TC (kW)	PI (kW)
40 °C	111.7	111.7	41.2	100.5	32.9	89.3	25.9	78.2	20.1	67.0	15.3	55.8	11.4	44.7	8.27	33.5	5.69	
39 °C	113.5	113.5	40.6	102.1	32.4	90.8	25.5	79.4	19.8	68.1	15.1	56.7	11.3	45.4	8.15	34.0	5.61	
37 °C	116.9	116.9	39.3	105.2	31.4	93.5	24.7	81.8	19.2	70.1	14.6	58.4	10.9	46.7	7.90	35.1	5.44	
35 °C	120.0	120.0	38.1	108.0	30.4	96.0	24.0	84.0	18.6	72.0	14.2	60.0	10.6	48.0	7.65	36.0	5.26	
33 °C	120.0	120.0	35.0	108.0	28.0	96.0	22.1	84.0	17.2	72.0	13.2	60.0	9.87	48.0	7.16	36.0	4.95	
31 °C	120.0	120.0	32.3	108.0	25.9	96.0	20.5	84.0	16.0	72.0	12.3	60.0	9.23	48.0	6.72	36.0	4.65	
30 °C	120.0	120.0	31.0	108.0	24.9	96.0	19.8	84.0	15.5	72.0	11.9	60.0	8.93	48.0	6.51	36.0	4.51	
29 °C	120.0	120.0	29.9	108.0	24.0	96.0	19.1	84.0	14.9	72.0	11.5	60.0	8.64	48.0	6.31	36.0	4.38	
27 °C	120.0	120.0	27.7	108.0	22.3	96.0	17.8	84.0	13.9	72.0	10.7	60.0	8.11	48.0	5.94	36.0	4.13	
25 °C	120.0	120.0	25.8	108.0	20.8	96.0	16.6	84.0	13.0	72.0	10.1	60.0	7.61	48.0	5.59	36.0	3.89	
23 °C	120.0	120.0	24.5	108.0	19.8	96.0	15.8	84.0	12.5	72.0	9.64	60.0	7.31	48.0	5.37	36.0	3.75	
21 °C	120.0	120.0	23.9	108.0	19.4	96.0	15.5	84.0	12.2	72.0	9.46	60.0	7.18	48.0	5.29	36.0	3.70	
20 °C	120.0	120.0	23.7	108.0	19.2	96.0	15.3	84.0	12.1	72.0	9.38	60.0	7.13	48.0	5.25	36.0	3.68	
19 °C	120.0	120.0	23.4	108.0	19.0	96.0	15.2	84.0	12.0	72.0	9.31	60.0	7.08	48.0	5.22	36.0	3.65	
17 °C	120.0	120.0	23.0	108.0	18.6	96.0	14.9	84.0	11.8	72.0	9.18	60.0	6.99	48.0	5.16	36.0	3.61	
15 °C	120.0	120.0	22.6	108.0	18.4	96.0	14.7	84.0	11.6	72.0	9.06	60.0	6.91	48.0	5.10	36.0	3.58	

TC : Total Capacity PI : Power Input
Indoor air temperature conditions : 27.0°C dry-bulb / 19.0°C wet bulb

Heating

Outdoor Unit Dry-Bulb (°C) / Wet-Bulb (°C)		Outdoor Unit 100% Heating Capacity (kW)	Compressor + Outdoor Fan Power consumption (kW)															
			100% Capacity		90% Capacity		80% Capacity		70% Capacity		60% Capacity		50% Capacity		40% Capacity		30% Capacity	
			TC (kW)	PI (kW)	TC (kW)	PI (kW)	TC (kW)	PI (kW)	TC (kW)	PI (kW)	TC (kW)	PI (kW)	TC (kW)	PI (kW)	TC (kW)	PI (kW)	TC (kW)	PI (kW)
15.0	13.7	120.0	120.0	25.5	108.0	21.0	96.0	17.4	84.0	14.4	72.0	12.0	60.0	9.92	48.0	8.13	36.0	6.49
13.0	11.8	120.0	120.0	26.7	108.0	22.0	96.0	18.1	84.0	14.9	72.0	12.3	60.0	10.1	48.0	8.29	36.0	6.60
11.0	9.8	120.0	120.0	28.2	108.0	23.0	96.0	18.8	84.0	15.4	72.0	12.7	60.0	10.4	48.0	8.47	36.0	6.72
9.0	7.9	120.0	120.0	29.7	108.0	24.2	96.0	19.7	84.0	16.0	72.0	13.1	60.0	10.7	48.0	8.65	36.0	6.84
7.0	6.0	120.0	120.0	31.5	108.0	25.5	96.0	20.6	84.0	16.6	72.0	13.5	60.0	11.0	48.0	8.84	36.0	6.98
5.0	4.1	116.1	116.1	31.3	104.5	25.3	92.9	20.5	81.3	16.6	69.7	13.4	58.1	10.9	46.5	8.79	34.8	6.94
3.0	2.2	112.3	112.3	31.1	101.0	25.2	89.8	20.3	78.6	16.5	67.4	13.3	56.1	10.8	44.9	8.74	33.7	6.90
0.0	-0.7	106.4	106.4	30.9	95.7	25.0	85.1	20.2	74.5	16.3	63.8	13.2	53.2	10.7	42.6	8.66	31.9	6.84
-3.0	-3.7	100.3	100.3	30.6	90.3	24.7	80.2	20.0	70.2	16.2	60.2	13.1	50.1	10.6	40.1	8.58	30.1	6.77
-5.0	-5.6	96.4	96.4	30.4	86.8	24.6	77.1	19.9	67.5	16.1	57.9	13.0	48.2	10.6	38.6	8.53	28.9	6.73
-7.0	-7.6	92.4	92.4	30.2	83.1	24.4	73.9	19.7	64.7	16.0	55.4	12.9	46.2	10.5	36.9	8.48	27.7	6.69
-10	-10.5	86.5	86.5	29.9	77.8	24.2	69.2	19.6	60.5	15.8	51.9	12.8	43.2	10.4	34.6	8.40	25.9	6.63
-14.5	-15.0	77.3	77.3	29.5	69.6	23.9	61.9	19.3	54.1	15.6	46.4	12.6	38.7	10.3	30.9	8.28	23.2	6.54

TC : Total Capacity PI : Power Input
Indoor air temperature conditions : 20.0°C dry-bulb



MMY-AP4416FT8P-E (44HP, 125kW system)

Cooling

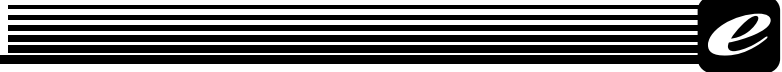
Outdoor Unit (°C)		Outdoor Unit 100% Capacity (kW)	Compressor + Outdoor Fan Power consumption (kW)															
			100%		90%		80%		70%		60%		50%		40%		30%	
			TC (kW)	PI (kW)	TC (kW)	PI (kW)	TC (kW)	PI (kW)	TC (kW)	PI (kW)	TC (kW)	PI (kW)	TC (kW)	PI (kW)	TC (kW)	PI (kW)	TC (kW)	PI (kW)
40 °C	116.3	116.3	42.5	104.7	33.8	93.1	26.5	81.4	20.5	69.8	15.5	58.2	11.5	46.5	8.29	34.9	5.67	
39 °C	118.2	118.2	41.8	106.4	33.3	94.6	26.1	82.7	20.2	70.9	15.3	59.1	11.4	47.3	8.17	35.5	5.59	
37 °C	121.7	121.7	40.6	109.6	32.3	97.4	25.3	85.2	19.6	73.0	14.8	60.9	11.0	48.7	7.92	36.5	5.42	
35 °C	125.0	125.0	39.3	112.5	31.3	100.0	24.5	87.5	19.0	75.0	14.4	62.5	10.7	50.0	7.67	37.5	5.25	
33 °C	125.0	125.0	36.1	112.5	28.8	100.0	22.6	87.5	17.5	75.0	13.4	62.5	9.94	50.0	7.18	37.5	4.93	
31 °C	125.0	125.0	33.2	112.5	26.6	100.0	21.0	87.5	16.3	75.0	12.4	62.5	9.29	50.0	6.73	37.5	4.64	
30 °C	125.0	125.0	31.9	112.5	25.6	100.0	20.2	87.5	15.7	75.0	12.0	62.5	8.99	50.0	6.52	37.5	4.50	
29 °C	125.0	125.0	30.7	112.5	24.6	100.0	19.5	87.5	15.2	75.0	11.6	62.5	8.70	50.0	6.32	37.5	4.36	
27 °C	125.0	125.0	28.5	112.5	22.9	100.0	18.1	87.5	14.1	75.0	10.9	62.5	8.16	50.0	5.94	37.5	4.11	
25 °C	125.0	125.0	26.5	112.5	21.3	100.0	16.9	87.5	13.2	75.0	10.2	62.5	7.65	50.0	5.59	37.5	3.88	
23 °C	125.0	125.0	25.2	112.5	20.3	100.0	16.1	87.5	12.6	75.0	9.74	62.5	7.35	50.0	5.37	37.5	3.73	
21 °C	125.0	125.0	24.6	112.5	19.8	100.0	15.8	87.5	12.4	75.0	9.56	62.5	7.22	50.0	5.29	37.5	3.68	
20 °C	125.0	125.0	24.3	112.5	19.6	100.0	15.6	87.5	12.3	75.0	9.47	62.5	7.16	50.0	5.25	37.5	3.66	
19 °C	125.0	125.0	24.1	112.5	19.4	100.0	15.5	87.5	12.2	75.0	9.40	62.5	7.11	50.0	5.21	37.5	3.64	
17 °C	125.0	125.0	23.6	112.5	19.1	100.0	15.2	87.5	12.0	75.0	9.26	62.5	7.01	50.0	5.15	37.5	3.60	
15 °C	125.0	125.0	23.2	112.5	18.8	100.0	15.0	87.5	11.8	75.0	9.14	62.5	6.93	50.0	5.10	37.5	3.56	

TC : Total Capacity PI : Power Input
Indoor air temperature conditions : 27.0°C dry-bulb / 19.0°C wet bulb

Heating

Outdoor Unit Dry-Bulb (°C) / Wet-Bulb (°C)		Outdoor Unit 100% Heating Capacity (kW)	Compressor + Outdoor Fan Power consumption (kW)															
			100% Capacity		90% Capacity		80% Capacity		70% Capacity		60% Capacity		50% Capacity		40% Capacity		30% Capacity	
			TC (kW)	PI (kW)	TC (kW)	PI (kW)	TC (kW)	PI (kW)	TC (kW)	PI (kW)	TC (kW)	PI (kW)	TC (kW)	PI (kW)	TC (kW)	PI (kW)	TC (kW)	PI (kW)
15.0	13.7	125.0	125.0	27.0	112.5	22.4	100.0	18.5	87.5	15.3	75.0	12.7	62.5	10.4	50.0	8.51	37.5	6.80
13.0	11.8	125.0	125.0	28.3	112.5	23.4	100.0	19.2	87.5	15.8	75.0	13.0	62.5	10.7	50.0	8.67	37.5	6.91
11.0	9.8	125.0	125.0	29.8	112.5	24.5	100.0	20.1	87.5	16.4	75.0	13.4	62.5	11.0	50.0	8.86	37.5	7.03
9.0	7.9	125.0	125.0	31.4	112.5	25.7	100.0	20.9	87.5	17.0	75.0	13.9	62.5	11.2	50.0	9.06	37.5	7.16
7.0	6.0	125.0	125.0	33.2	112.5	27.0	100.0	21.9	87.5	17.7	75.0	14.3	62.5	11.6	50.0	9.27	37.5	7.30
5.0	4.1	120.8	120.8	33.0	108.7	26.8	96.6	21.8	84.6	17.6	72.5	14.2	60.4	11.5	48.3	9.21	36.2	7.25
3.0	2.2	116.6	116.6	32.8	105.0	26.7	93.3	21.6	81.6	17.5	70.0	14.1	58.3	11.4	46.7	9.15	35.0	7.20
0.0	-0.7	110.2	110.2	32.4	99.2	26.4	88.2	21.4	77.2	17.3	66.1	14.0	55.1	11.3	44.1	9.06	33.1	7.13
-3.0	-3.7	103.6	103.6	32.1	93.3	26.1	82.9	21.2	72.5	17.1	62.2	13.9	51.8	11.2	41.5	8.97	31.1	7.06
-5.0	-5.6	99.5	99.5	31.9	89.5	25.9	79.6	21.0	69.6	17.0	59.7	13.8	49.7	11.1	39.8	8.91	29.8	7.01
-7.0	-7.6	95.0	95.0	31.7	85.5	25.8	76.0	20.9	66.5	16.9	57.0	13.7	47.5	11.0	38.0	8.84	28.5	6.96
-10	-10.5	88.7	88.7	31.3	79.8	25.5	70.9	20.7	62.1	16.7	53.2	13.5	44.3	10.9	35.5	8.75	26.6	6.89
-14.5	-15.0	78.8	78.8	30.8	70.9	25.1	63.0	20.3	55.1	16.5	47.3	13.3	39.4	10.7	31.5	8.61	23.6	6.78

TC : Total Capacity PI : Power Input
Indoor air temperature conditions : 20.0°C dry-bulb



MMY-AP4616FT8P-E (46HP, 130.4kW system)

Cooling

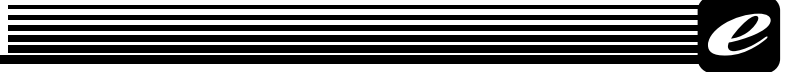
Outdoor Unit (°C)		Outdoor Unit 100% Capacity (kW)	Compressor + Outdoor Fan Power consumption (kW)															
			100%		90%		80%		70%		60%		50%		40%		30%	
			TC (kW)	PI (kW)	TC (kW)	PI (kW)	TC (kW)	PI (kW)	TC (kW)	PI (kW)	TC (kW)	PI (kW)	TC (kW)	PI (kW)	TC (kW)	PI (kW)	TC (kW)	PI (kW)
40 °C		121.4	121.4	44.7	109.2	35.2	97.1	27.3	84.9	20.8	72.8	15.7	60.7	11.6	48.5	8.49	36.4	6.07
39 °C		123.3	123.3	44.1	111.0	34.7	98.6	26.9	86.3	20.5	74.0	15.5	61.7	11.5	49.3	8.37	37.0	5.98
37 °C		127.0	127.0	42.7	114.3	33.6	101.6	26.1	88.9	19.9	76.2	15.0	63.5	11.1	50.8	8.11	38.1	5.80
35 °C		130.4	130.4	41.4	117.3	32.5	104.3	25.2	91.3	19.3	78.2	14.5	65.2	10.8	52.2	7.86	39.1	5.62
33 °C		130.4	130.4	37.9	117.4	29.9	104.3	23.2	91.3	17.8	78.2	13.5	65.2	10.0	52.2	7.37	39.1	5.30
31 °C		130.4	130.4	34.8	117.4	27.5	104.3	21.5	91.3	16.5	78.2	12.5	65.2	9.39	52.2	6.93	39.1	5.01
30 °C		130.4	130.4	33.4	117.4	26.5	104.3	20.7	91.3	15.9	78.2	12.1	65.2	9.09	52.2	6.72	39.1	4.87
29 °C		130.4	130.4	32.1	117.4	25.5	104.3	19.9	91.3	15.4	78.2	11.7	65.2	8.80	52.2	6.52	39.1	4.74
27 °C		130.4	130.4	29.8	117.4	23.6	104.3	18.5	91.3	14.3	78.2	10.9	65.2	8.26	52.2	6.14	39.1	4.48
25 °C		130.4	130.4	27.6	117.4	21.9	104.3	17.2	91.3	13.4	78.2	10.3	65.2	7.76	52.2	5.79	39.1	4.24
23 °C		130.4	130.4	26.2	117.4	20.9	104.3	16.4	91.3	12.8	78.2	9.82	65.2	7.45	52.2	5.58	39.1	4.09
21 °C		130.4	130.4	25.6	117.4	20.4	104.3	16.1	91.3	12.5	78.2	9.63	65.2	7.33	52.2	5.50	39.1	4.05
20 °C		130.4	130.4	25.2	117.4	20.1	104.3	15.9	91.3	12.4	78.2	9.55	65.2	7.27	52.2	5.46	39.1	4.03
19 °C		130.4	130.4	25.0	117.4	19.9	104.3	15.7	91.3	12.3	78.2	9.48	65.2	7.22	52.2	5.43	39.1	4.01
17 °C		130.4	130.4	24.5	117.4	19.6	104.3	15.5	91.3	12.1	78.2	9.34	65.2	7.13	52.2	5.37	39.1	3.97
15 °C		130.4	130.4	24.1	117.4	19.2	104.3	15.2	91.3	11.9	78.2	9.22	65.2	7.06	52.2	5.33	39.1	3.94

TC : Total Capacity PI : Power Input
Indoor air temperature conditions : 27.0°C dry-bulb / 19.0°C wet bulb

Heating

Outdoor Unit Dry-Bulb (°C) / Wet-Bulb (°C)		Outdoor Unit 100% Heating Capacity (kW)	Compressor + Outdoor Fan Power consumption (kW)															
			100% Capacity		90% Capacity		80% Capacity		70% Capacity		60% Capacity		50% Capacity		40% Capacity		30% Capacity	
			TC (kW)	PI (kW)	TC (kW)	PI (kW)	TC (kW)	PI (kW)	TC (kW)	PI (kW)	TC (kW)	PI (kW)	TC (kW)	PI (kW)	TC (kW)	PI (kW)	TC (kW)	PI (kW)
15.0	13.7	130.4	130.4	28.4	117.4	23.6	104.3	19.7	91.3	16.3	78.2	13.5	65.2	11.1	52.2	8.92	39.1	6.90
13.0	11.8	130.4	130.4	29.7	117.4	24.6	104.3	20.4	91.3	16.9	78.2	13.9	65.2	11.4	52.2	9.11	39.1	7.04
11.0	9.8	130.4	130.4	31.2	117.4	25.8	104.3	21.3	91.3	17.5	78.2	14.3	65.2	11.7	52.2	9.33	39.1	7.20
9.0	7.9	130.4	130.4	32.9	117.4	27.0	104.3	22.2	91.3	18.1	78.2	14.8	65.2	12.0	52.2	9.56	39.1	7.35
7.0	6.0	130.4	130.4	34.7	117.4	28.4	104.3	23.1	91.3	18.8	78.2	15.3	65.2	12.3	52.2	9.80	39.1	7.52
5.0	4.1	126.2	126.2	34.5	113.6	28.2	101.0	23.0	88.3	18.7	75.7	15.2	63.1	12.3	50.5	9.74	37.9	7.47
3.0	2.2	122.0	122.0	34.3	109.8	28.0	97.6	22.9	85.4	18.6	73.2	15.1	61.0	12.2	48.8	9.68	36.6	7.43
0.0	-0.7	115.6	115.6	34.0	104.0	27.8	92.5	22.7	80.9	18.5	69.4	15.0	57.8	12.1	46.2	9.60	34.7	7.37
-3.0	-3.7	109.0	109.0	33.7	98.1	27.5	87.2	22.5	76.3	18.3	65.4	14.8	54.5	12.0	43.6	9.51	32.7	7.30
-5.0	-5.6	104.8	104.8	33.5	94.3	27.4	83.8	22.3	73.4	18.2	62.9	14.8	52.4	11.9	41.9	9.45	31.4	7.26
-7.0	-7.6	100.4	100.4	33.3	90.3	27.2	80.3	22.2	70.3	18.1	60.2	14.7	50.2	11.8	40.2	9.40	30.1	7.21
-10	-10.5	94.0	94.0	33.0	84.6	27.0	75.2	22.0	65.8	17.9	56.4	14.5	47.0	11.7	37.6	9.31	28.2	7.14
-14.5	-15.0	84.0	84.0	32.5	75.6	26.6	67.2	21.7	58.8	17.6	50.4	14.3	42.0	11.6	33.6	9.18	25.2	7.04

TC : Total Capacity PI : Power Input
Indoor air temperature conditions : 20.0°C dry-bulb



MMY-AP4816FT8P-E (48HP, 135.4kW system)

Cooling

Outdoor Unit (°C)		Outdoor Unit 100% Capacity (kW)	Compressor + Outdoor Fan Power consumption (kW)															
			100%		90%		80%		70%		60%		50%		40%		30%	
			TC (kW)	PI (kW)	TC (kW)	PI (kW)	TC (kW)	PI (kW)	TC (kW)	PI (kW)	TC (kW)	PI (kW)	TC (kW)	PI (kW)	TC (kW)	PI (kW)	TC (kW)	PI (kW)
40 °C	126.0	126.0	46.0	113.4	36.1	100.8	27.9	88.2	21.2	75.6	15.9	63.0	11.7	50.4	8.51	37.8	6.06	
39 °C	128.0	128.0	45.3	115.2	35.6	102.4	27.5	89.6	20.9	76.8	15.7	64.0	11.6	51.2	8.38	38.4	5.97	
37 °C	131.9	131.9	44.0	118.7	34.5	105.5	26.6	92.3	20.3	79.1	15.2	65.9	11.2	52.7	8.13	39.6	5.79	
35 °C	135.4	135.4	42.6	121.8	33.4	108.3	25.8	94.8	19.6	81.2	14.7	67.7	10.8	54.2	7.87	40.6	5.60	
33 °C	135.4	135.4	39.0	121.9	30.6	108.3	23.7	94.8	18.1	81.2	13.6	67.7	10.1	54.2	7.38	40.6	5.29	
31 °C	135.4	135.4	35.8	121.9	28.2	108.3	21.9	94.8	16.8	81.2	12.7	67.7	9.45	54.2	6.94	40.6	4.99	
30 °C	135.4	135.4	34.4	121.9	27.1	108.3	21.1	94.8	16.2	81.2	12.3	67.7	9.15	54.2	6.73	40.6	4.85	
29 °C	135.4	135.4	33.0	121.9	26.1	108.3	20.3	94.8	15.6	81.2	11.8	67.7	8.85	54.2	6.53	40.6	4.72	
27 °C	135.4	135.4	30.5	121.9	24.2	108.3	18.9	94.8	14.5	81.2	11.1	67.7	8.31	54.2	6.15	40.6	4.46	
25 °C	135.4	135.4	28.3	121.9	22.5	108.3	17.6	94.8	13.6	81.2	10.4	67.7	7.80	54.2	5.79	40.6	4.22	
23 °C	135.4	135.4	26.9	121.9	21.4	108.3	16.7	94.8	13.0	81.2	9.92	67.7	7.49	54.2	5.58	40.6	4.08	
21 °C	135.4	135.4	26.2	121.9	20.8	108.3	16.4	94.8	12.7	81.2	9.73	67.7	7.36	54.2	5.50	40.6	4.03	
20 °C	135.4	135.4	25.9	121.9	20.6	108.3	16.2	94.8	12.6	81.2	9.64	67.7	7.31	54.2	5.46	40.6	4.01	
19 °C	135.4	135.4	25.6	121.9	20.4	108.3	16.0	94.8	12.5	81.2	9.56	67.7	7.25	54.2	5.43	40.6	3.99	
17 °C	135.4	135.4	25.1	121.9	20.0	108.3	15.7	94.8	12.2	81.2	9.42	67.7	7.16	54.2	5.37	40.6	3.96	
15 °C	135.4	135.4	24.6	121.9	19.7	108.3	15.5	94.8	12.1	81.2	9.30	67.7	7.08	54.2	5.32	40.6	3.93	

TC : Total Capacity PI : Power Input
Indoor air temperature conditions : 27.0°C dry-bulb / 19.0°C wet bulb

Heating

Outdoor Unit Dry-Bulb (°C) / Wet-Bulb (°C)		Outdoor Unit 100% Heating Capacity (kW)	Compressor + Outdoor Fan Power consumption (kW)															
			100% Capacity		90% Capacity		80% Capacity		70% Capacity		60% Capacity		50% Capacity		40% Capacity		30% Capacity	
			TC (kW)	PI (kW)	TC (kW)	PI (kW)	TC (kW)	PI (kW)	TC (kW)	PI (kW)	TC (kW)	PI (kW)	TC (kW)	PI (kW)	TC (kW)	PI (kW)	TC (kW)	PI (kW)
15.0	13.7	135.4	135.4	29.9	121.9	25.0	108.3	20.8	94.8	17.2	81.2	14.2	67.7	11.6	54.2	9.29	40.6	7.21
13.0	11.8	135.4	135.4	31.3	121.9	26.0	108.3	21.6	94.8	17.8	81.2	14.6	67.7	11.9	54.2	9.50	40.6	7.35
11.0	9.8	135.4	135.4	32.9	121.9	27.2	108.3	22.5	94.8	18.5	81.2	15.1	67.7	12.2	54.2	9.73	40.6	7.51
9.0	7.9	135.4	135.4	34.5	121.9	28.5	108.3	23.4	94.8	19.2	81.2	15.6	67.7	12.6	54.2	10.0	40.6	7.67
7.0	6.0	135.4	135.4	36.6	121.9	29.9	108.3	24.5	94.8	19.9	81.2	16.1	67.7	12.9	54.2	10.2	40.6	7.84
5.0	4.1	130.9	130.9	36.2	117.8	29.7	104.7	24.3	91.6	19.8	78.5	16.0	65.4	12.9	52.4	10.2	39.3	7.79
3.0	2.2	126.4	126.4	35.9	113.7	29.5	101.1	24.1	88.5	19.6	75.8	15.9	63.2	12.8	50.5	10.1	37.9	7.74
0.0	-0.7	119.5	119.5	35.6	107.5	29.2	95.6	23.9	83.6	19.5	71.7	15.8	59.7	12.6	47.8	10.0	35.8	7.66
-3.0	-3.7	112.3	112.3	35.2	101.1	28.9	89.9	23.7	78.6	19.3	67.4	15.6	56.2	12.5	44.9	9.89	33.7	7.58
-5.0	-5.6	107.8	107.8	35.0	97.0	28.7	86.2	23.5	75.5	19.1	64.7	15.5	53.9	12.4	43.1	9.83	32.3	7.53
-7.0	-7.6	103.1	103.1	34.7	92.7	28.5	82.4	23.3	72.1	19.0	61.8	15.4	51.5	12.3	41.2	9.76	30.9	7.48
-10	-10.5	96.2	96.2	34.4	86.5	28.3	76.9	23.1	67.3	18.8	57.7	15.2	48.1	12.2	38.5	9.66	28.8	7.41
-14.5	-15.0	85.5	85.5	33.8	76.9	27.8	68.4	22.7	59.8	18.5	51.3	15.0	42.7	12.0	34.2	9.51	25.6	7.29

TC : Total Capacity PI : Power Input
Indoor air temperature conditions : 20.0°C dry-bulb



MMY-AP5016FT8P-E (50HP, 140.8kW system)

Cooling

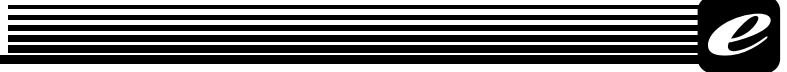
Outdoor Unit (°C)		Outdoor Unit 100% Capacity (kW)	Compressor + Outdoor Fan Power consumption (kW)															
			100%		90%		80%		70%		60%		50%		40%		30%	
			TC (kW)	PI (kW)	TC (kW)	PI (kW)	TC (kW)	PI (kW)	TC (kW)	PI (kW)	TC (kW)	PI (kW)	TC (kW)	PI (kW)	TC (kW)	PI (kW)	TC (kW)	PI (kW)
40 °C	131.0	131.0	48.3	117.9	37.5	104.8	28.6	91.7	21.6	78.6	16.0	65.5	11.8	52.4	8.71	39.3	6.46	
39 °C	133.1	133.1	47.6	119.8	36.9	106.5	28.2	93.2	21.3	79.9	15.8	66.6	11.7	53.3	8.58	39.9	6.36	
37 °C	137.1	137.1	46.1	123.4	35.8	109.7	27.4	96.0	20.6	82.3	15.3	68.6	11.3	54.8	8.32	41.1	6.17	
35 °C	140.8	140.8	44.7	126.7	34.7	112.6	26.5	98.5	20.0	84.5	14.8	70.4	10.9	56.3	8.06	42.2	5.97	
33 °C	140.8	140.8	40.8	126.7	31.7	112.6	24.3	98.6	18.4	84.5	13.8	70.4	10.2	56.3	7.58	42.2	5.66	
31 °C	140.8	140.8	37.4	126.7	29.2	112.6	22.4	98.6	17.0	84.5	12.8	70.4	9.56	56.3	7.13	42.2	5.37	
30 °C	140.8	140.8	35.9	126.7	28.0	112.6	21.6	98.6	16.4	84.5	12.4	70.4	9.25	56.3	6.93	42.2	5.23	
29 °C	140.8	140.8	34.4	126.7	26.9	112.6	20.8	98.6	15.8	84.5	11.9	70.4	8.96	56.3	6.73	42.2	5.09	
27 °C	140.8	140.8	31.8	126.7	24.9	112.6	19.3	98.6	14.7	84.5	11.2	70.4	8.41	56.3	6.35	42.2	4.83	
25 °C	140.8	140.8	29.4	126.7	23.1	112.6	17.9	98.6	13.7	84.5	10.4	70.4	7.90	56.3	5.99	42.2	4.58	
23 °C	140.8	140.8	27.9	126.7	22.0	112.6	17.1	98.6	13.1	84.5	10.0	70.4	7.60	56.3	5.78	42.2	4.44	
21 °C	140.8	140.8	27.2	126.7	21.4	112.6	16.6	98.6	12.8	84.5	9.81	70.4	7.47	56.3	5.71	42.2	4.40	
20 °C	140.8	140.8	26.8	126.7	21.1	112.6	16.5	98.6	12.7	84.5	9.72	70.4	7.42	56.3	5.68	42.2	4.38	
19 °C	140.8	140.8	26.5	126.7	20.9	112.6	16.3	98.6	12.6	84.5	9.64	70.4	7.37	56.3	5.65	42.2	4.36	
17 °C	140.8	140.8	26.0	126.7	20.5	112.6	16.0	98.6	12.4	84.5	9.50	70.4	7.28	56.3	5.59	42.2	4.33	
15 °C	140.8	140.8	25.5	126.7	20.1	112.6	15.7	98.6	12.2	84.5	9.38	70.4	7.20	56.3	5.55	42.2	4.31	

TC : Total Capacity PI : Power Input
Indoor air temperature conditions : 27.0°C dry-bulb / 19.0°C wet bulb

Heating

Outdoor Unit Dry-Bulb (°C) / Wet-Bulb (°C)		Outdoor Unit 100% Heating Capacity (kW)	Compressor + Outdoor Fan Power consumption (kW)															
			100% Capacity		90% Capacity		80% Capacity		70% Capacity		60% Capacity		50% Capacity		40% Capacity		30% Capacity	
			TC (kW)	PI (kW)	TC (kW)	PI (kW)	TC (kW)	PI (kW)	TC (kW)	PI (kW)	TC (kW)	PI (kW)	TC (kW)	PI (kW)	TC (kW)	PI (kW)	TC (kW)	PI (kW)
15.0	13.7	140.8	140.8	31.3	126.7	26.3	112.6	21.9	98.6	18.3	84.5	15.1	70.4	12.2	56.3	9.71	42.2	7.32
13.0	11.8	140.8	140.8	32.7	126.7	27.3	112.6	22.7	98.6	18.8	84.5	15.5	70.4	12.6	56.3	9.94	42.2	7.49
11.0	9.8	140.8	140.8	34.3	126.7	28.5	112.6	23.7	98.6	19.5	84.5	16.0	70.4	12.9	56.3	10.2	42.2	7.67
9.0	7.9	140.8	140.8	36.0	126.7	29.8	112.6	24.6	98.6	20.2	84.5	16.5	70.4	13.3	56.3	10.5	42.2	7.86
7.0	6.0	140.8	140.8	38.1	126.7	31.3	112.6	25.7	98.6	21.0	84.5	17.1	70.4	13.7	56.3	10.8	42.2	8.06
5.0	4.1	136.3	136.3	37.7	122.6	31.1	109.0	25.5	95.4	20.9	81.8	17.0	68.1	13.6	54.5	10.7	40.9	8.01
3.0	2.2	131.7	131.7	37.5	118.6	30.9	105.4	25.4	92.2	20.8	79.0	16.9	65.9	13.5	52.7	10.6	39.5	7.97
0.0	-0.7	124.8	124.8	37.1	112.3	30.6	99.9	25.2	87.4	20.6	74.9	16.7	62.4	13.4	49.9	10.5	37.4	7.90
-3.0	-3.7	117.7	117.7	36.8	105.9	30.4	94.1	24.9	82.4	20.4	70.6	16.6	58.8	13.3	47.1	10.4	35.3	7.82
-5.0	-5.6	113.2	113.2	36.6	101.8	30.2	90.5	24.8	79.2	20.3	67.9	16.5	56.6	13.2	45.3	10.4	33.9	7.78
-7.0	-7.6	108.4	108.4	36.3	97.5	30.0	86.7	24.6	75.9	20.2	65.0	16.4	54.2	13.1	43.4	10.3	32.5	7.73
-10	-10.5	101.5	101.5	36.0	91.3	29.7	81.2	24.4	71.0	20.0	60.9	16.2	50.7	13.0	40.6	10.2	30.4	7.66
-14.5	-15.0	90.8	90.8	35.5	81.7	29.3	72.6	24.1	63.5	19.7	54.5	16.0	45.4	12.8	36.3	10.1	27.2	7.55

TC : Total Capacity PI : Power Input
Indoor air temperature conditions : 20.0°C dry-bulb



MMY-AP5216FT8P-E (52HP, 145.8kW system)

Cooling

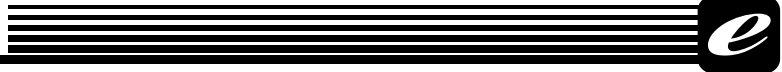
Outdoor Unit (°C)		Outdoor Unit 100% Capacity (kW)	Compressor + Outdoor Fan Power consumption (kW)															
			100%		90%		80%		70%		60%		50%		40%		30%	
			TC (kW)	PI (kW)	TC (kW)	PI (kW)	TC (kW)	PI (kW)	TC (kW)	PI (kW)	TC (kW)	PI (kW)	TC (kW)	PI (kW)	TC (kW)	PI (kW)	TC (kW)	PI (kW)
40 °C		135.7	135.7	49.6	122.1	38.4	108.5	29.2	95.0	21.9	81.4	16.3	67.8	11.9	54.3	8.73	40.7	6.44
39 °C		137.9	137.9	48.9	124.1	37.8	110.3	28.8	96.5	21.6	82.7	16.0	68.9	11.7	55.1	8.60	41.4	6.35
37 °C		142.0	142.0	47.4	127.8	36.7	113.6	27.9	99.4	21.0	85.2	15.5	71.0	11.4	56.8	8.34	42.6	6.15
35 °C		145.8	145.8	45.9	131.2	35.5	116.6	27.1	102.0	20.3	87.5	15.0	72.9	11.0	58.3	8.08	43.7	5.96
33 °C		145.8	145.8	41.8	131.2	32.5	116.6	24.8	102.1	18.7	87.5	13.9	72.9	10.3	58.3	7.59	43.7	5.64
31 °C		145.8	145.8	38.4	131.2	29.8	116.6	22.9	102.1	17.3	87.5	12.9	72.9	9.62	58.3	7.14	43.7	5.35
30 °C		145.8	145.8	36.8	131.2	28.6	116.6	22.0	102.1	16.7	87.5	12.5	72.9	9.31	58.3	6.93	43.7	5.21
29 °C		145.8	145.8	35.3	131.2	27.5	116.6	21.2	102.1	16.1	87.5	12.1	72.9	9.01	58.3	6.73	43.7	5.07
27 °C		145.8	145.8	32.6	131.2	25.5	116.6	19.6	102.1	14.9	87.5	11.3	72.9	8.46	58.3	6.35	43.7	4.81
25 °C		145.8	145.8	30.2	131.2	23.6	116.6	18.2	102.1	13.9	87.5	10.5	72.9	7.95	58.3	6.00	43.7	4.56
23 °C		145.8	145.8	28.6	131.2	22.4	116.6	17.4	102.1	13.3	87.5	10.1	72.9	7.63	58.3	5.78	43.7	4.42
21 °C		145.8	145.8	27.8	131.2	21.8	116.6	16.9	102.1	13.0	87.5	9.90	72.9	7.51	58.3	5.71	43.7	4.38
20 °C		145.8	145.8	27.5	131.2	21.6	116.6	16.8	102.1	12.9	87.5	9.81	72.9	7.45	58.3	5.68	43.7	4.36
19 °C		145.8	145.8	27.1	131.2	21.3	116.6	16.6	102.1	12.7	87.5	9.73	72.9	7.40	58.3	5.65	43.7	4.35
17 °C		145.8	145.8	26.6	131.2	20.9	116.6	16.3	102.1	12.5	87.5	9.58	72.9	7.31	58.3	5.59	43.7	4.32
15 °C		145.8	145.8	26.1	131.2	20.5	116.6	16.0	102.1	12.3	87.5	9.46	72.9	7.23	58.3	5.54	43.7	4.29

TC : Total Capacity PI : Power Input
Indoor air temperature conditions : 27.0°C dry-bulb / 19.0°C wet bulb

Heating

Outdoor Unit Dry-Bulb (°C) / Wet-Bulb (°C)		Outdoor Unit 100% Heating Capacity (kW)	Compressor + Outdoor Fan Power consumption (kW)															
			100% Capacity		90% Capacity		80% Capacity		70% Capacity		60% Capacity		50% Capacity		40% Capacity		30% Capacity	
			TC (kW)	PI (kW)	TC (kW)	PI (kW)	TC (kW)	PI (kW)	TC (kW)	PI (kW)	TC (kW)	PI (kW)	TC (kW)	PI (kW)	TC (kW)	PI (kW)	TC (kW)	PI (kW)
15.0	13.7	145.8	145.8	32.8	131.2	27.6	116.6	23.1	102.1	19.2	87.5	15.7	72.9	12.8	58.3	10.1	43.7	7.63
13.0	11.8	145.8	145.8	34.3	131.2	28.7	116.6	23.9	102.1	19.8	87.5	16.2	72.9	13.1	58.3	10.3	43.7	7.80
11.0	9.8	145.8	145.8	35.9	131.2	30.0	116.6	24.9	102.1	20.5	87.5	16.7	72.9	13.5	58.3	10.6	43.7	7.99
9.0	7.9	145.8	145.8	37.7	131.2	31.3	116.6	25.9	102.1	21.3	87.5	17.3	72.9	13.9	58.3	10.9	43.7	8.18
7.0	6.0	145.8	145.8	39.6	131.2	32.8	116.6	27.0	102.1	22.1	87.5	17.9	72.9	14.3	58.3	11.2	43.7	8.38
5.0	4.1	140.9	140.9	39.3	126.8	32.6	112.8	26.8	98.7	21.9	84.6	17.8	70.5	14.2	56.4	11.1	42.3	8.33
3.0	2.2	136.1	136.1	39.1	122.5	32.4	108.9	26.7	95.3	21.8	81.7	17.7	68.0	14.1	54.4	11.0	40.8	8.27
0.0	-0.7	128.7	128.7	38.7	115.8	32.1	102.9	26.4	90.1	21.6	77.2	17.5	64.3	14.0	51.5	10.9	38.6	8.19
-3.0	-3.7	121.0	121.0	38.3	108.9	31.7	96.8	26.1	84.7	21.4	72.6	17.3	60.5	13.8	48.4	10.8	36.3	8.11
-5.0	-5.6	116.2	116.2	38.1	104.6	31.5	92.9	26.0	81.3	21.2	69.7	17.2	58.1	13.8	46.5	10.7	34.9	8.06
-7.0	-7.6	111.1	111.1	37.8	100.0	31.3	88.8	25.8	77.7	21.1	66.6	17.1	55.5	13.7	44.4	10.7	33.3	8.00
-10	-10.5	103.7	103.7	37.4	93.3	31.0	82.9	25.5	72.6	20.9	62.2	16.9	51.8	13.5	41.5	10.6	31.1	7.92
-14.5	-15.0	92.2	92.2	36.8	82.9	30.5	73.7	25.1	64.5	20.6	55.3	16.7	46.1	13.3	36.9	10.4	27.6	7.79

TC : Total Capacity PI : Power Input
Indoor air temperature conditions : 20.0°C dry-bulb



MMY-AP5416FT8P-E (54HP, 151.2kW system)

Cooling

Outdoor Unit (°C)		Outdoor Unit 100% Capacity (kW)	Compressor + Outdoor Fan Power consumption (kW)															
			100%		90%		80%		70%		60%		50%		40%		30%	
			TC (kW)	PI (kW)	TC (kW)	PI (kW)	TC (kW)	PI (kW)	TC (kW)	PI (kW)	TC (kW)	PI (kW)	TC (kW)	PI (kW)	TC (kW)	PI (kW)	TC (kW)	PI (kW)
40 °C	140.7	140.7	51.9	126.6	39.8	112.6	30.0	98.5	22.3	84.4	16.4	70.4	12.0	56.3	8.93	42.2	6.84	
39 °C	143.0	143.0	51.1	128.7	39.2	114.4	29.6	100.1	22.0	85.8	16.2	71.5	11.9	57.2	8.80	42.9	6.74	
37 °C	147.2	147.2	49.5	132.5	38.0	117.8	28.7	103.1	21.3	88.3	15.7	73.6	11.5	58.9	8.54	44.2	6.54	
35 °C	151.2	151.2	48.0	136.1	36.8	120.9	27.8	105.8	20.6	90.7	15.2	75.6	11.1	60.5	8.27	45.4	6.33	
33 °C	151.2	151.2	43.7	136.1	33.6	121.0	25.4	105.8	19.0	90.7	14.0	75.6	10.4	60.5	7.78	45.4	6.02	
31 °C	151.2	151.2	39.9	136.1	30.8	121.0	23.4	105.8	17.5	90.7	13.1	75.6	9.72	60.5	7.34	45.4	5.72	
30 °C	151.2	151.2	38.3	136.1	29.5	121.0	22.5	105.8	16.9	90.7	12.6	75.6	9.41	60.5	7.14	45.4	5.58	
29 °C	151.2	151.2	36.7	136.1	28.4	121.0	21.6	105.8	16.3	90.7	12.2	75.6	9.11	60.5	6.94	45.4	5.45	
27 °C	151.2	151.2	33.8	136.1	26.2	121.0	20.0	105.8	15.1	90.7	11.4	75.6	8.56	60.5	6.56	45.4	5.18	
25 °C	151.2	151.2	31.3	136.1	24.3	121.0	18.6	105.8	14.1	90.7	10.6	75.6	8.05	60.5	6.20	45.4	4.93	
23 °C	151.2	151.2	29.6	136.1	23.0	121.0	17.7	105.8	13.4	90.7	10.2	75.6	7.74	60.5	5.99	45.4	4.78	
21 °C	151.2	151.2	28.8	136.1	22.4	121.0	17.2	105.8	13.1	90.7	10.0	75.6	7.62	60.5	5.92	45.4	4.75	
20 °C	151.2	151.2	28.4	136.1	22.1	121.0	17.0	105.8	13.0	90.7	9.89	75.6	7.57	60.5	5.89	45.4	4.73	
19 °C	151.2	151.2	28.1	136.1	21.9	121.0	16.8	105.8	12.9	90.7	9.81	75.6	7.52	60.5	5.86	45.4	4.72	
17 °C	151.2	151.2	27.4	136.1	21.4	121.0	16.5	105.8	12.7	90.7	9.66	75.6	7.43	60.5	5.81	45.4	4.69	
15 °C	151.2	151.2	26.9	136.1	21.0	121.0	16.3	105.8	12.5	90.7	9.54	75.6	7.35	60.5	5.77	45.4	4.67	

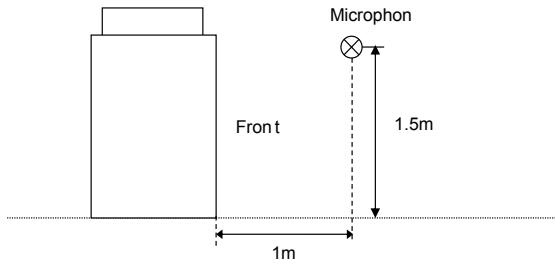
TC : Total Capacity PI : Power Input
Indoor air temperature conditions : 27.0°C dry-bulb / 19.0°C wet bulb

Heating

Outdoor Unit Dry-Bulb (°C) / Wet-Bulb (°C)		Outdoor Unit 100% Heating Capacity (kW)	Compressor + Outdoor Fan Power consumption (kW)															
			100% Capacity		90% Capacity		80% Capacity		70% Capacity		60% Capacity		50% Capacity		40% Capacity		30% Capacity	
			TC (kW)	PI (kW)	TC (kW)	PI (kW)	TC (kW)	PI (kW)	TC (kW)	PI (kW)	TC (kW)	PI (kW)	TC (kW)	PI (kW)	TC (kW)	PI (kW)	TC (kW)	PI (kW)
15.0	13.7	151.2	151.2	34.2	136.1	28.9	121.0	24.2	105.8	20.2	90.7	16.6	75.6	13.4	60.5	10.5	45.4	7.74
13.0	11.8	151.2	151.2	35.7	136.1	30.0	121.0	25.1	105.8	20.8	90.7	17.1	75.6	13.8	60.5	10.8	45.4	7.93
11.0	9.8	151.2	151.2	37.4	136.1	31.3	121.0	26.1	105.8	21.6	90.7	17.7	75.6	14.2	60.5	11.1	45.4	8.15
9.0	7.9	151.2	151.2	39.1	136.1	32.7	121.0	27.1	105.8	22.4	90.7	18.2	75.6	14.6	60.5	11.4	45.4	8.37
7.0	6.0	151.2	151.2	41.1	136.1	34.2	121.0	28.3	105.8	23.2	90.7	18.9	75.6	15.1	60.5	11.7	45.4	8.60
5.0	4.1	146.3	146.3	40.9	131.7	34.0	117.1	28.1	102.4	23.1	87.8	18.7	73.2	15.0	58.5	11.6	43.9	8.55
3.0	2.2	141.5	141.5	40.6	127.3	33.8	113.2	27.9	99.0	22.9	84.9	18.6	70.7	14.9	56.6	11.6	42.4	8.50
0.0	-0.7	134.0	134.0	40.3	120.6	33.5	107.2	27.7	93.8	22.7	80.4	18.5	67.0	14.8	53.6	11.5	40.2	8.42
-3.0	-3.7	126.4	126.4	39.9	113.7	33.2	101.1	27.4	88.5	22.5	75.8	18.3	63.2	14.6	50.5	11.4	37.9	8.35
-5.0	-5.6	121.5	121.5	39.7	109.4	33.0	97.2	27.3	85.1	22.4	72.9	18.2	60.8	14.5	48.6	11.3	36.5	8.30
-7.0	-7.6	116.4	116.4	39.4	104.8	32.8	93.1	27.1	81.5	22.2	69.8	18.1	58.2	14.5	46.6	11.2	34.9	8.25
-10	-10.5	109.0	109.0	39.1	98.1	32.5	87.2	26.8	76.3	22.0	65.4	17.9	54.5	14.3	43.6	11.1	32.7	8.17
-14.5	-15.0	97.5	97.5	38.5	87.7	32.0	78.0	26.5	68.2	21.7	58.5	17.7	48.7	14.1	39.0	11.0	29.2	8.06

TC : Total Capacity PI : Power Input
Indoor air temperature conditions : 20.0°C dry-bulb

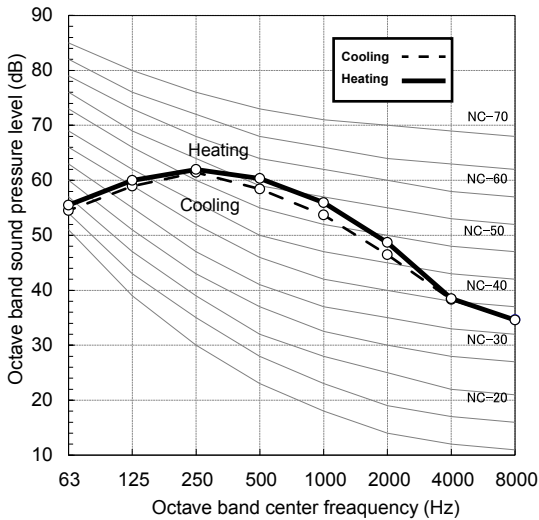
5-11. Sound pressure level data



Standard model

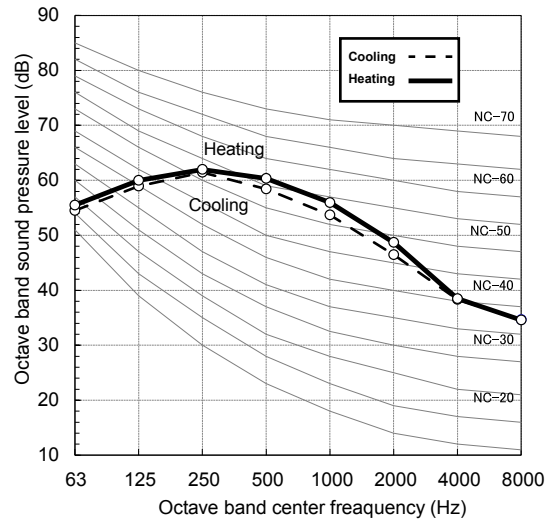
MMY-MAP0806FT8P-E

Sound pressure Level (dB(A))	Cooling	Heating
	59.0	61.0



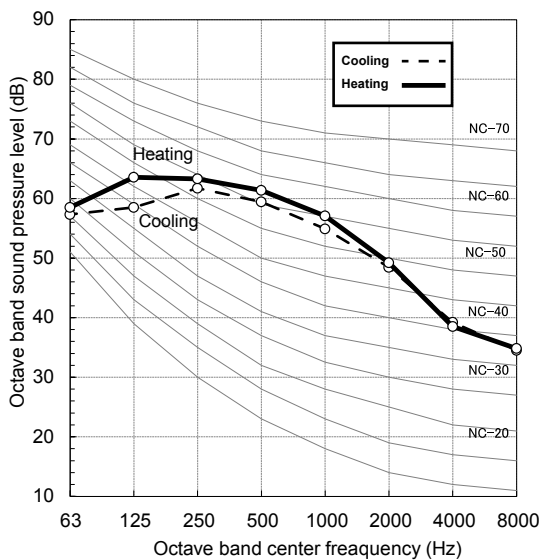
MMY-MAP1006FT8P-E

Sound pressure Level (dB(A))	Cooling	Heating
	59.0	61.0



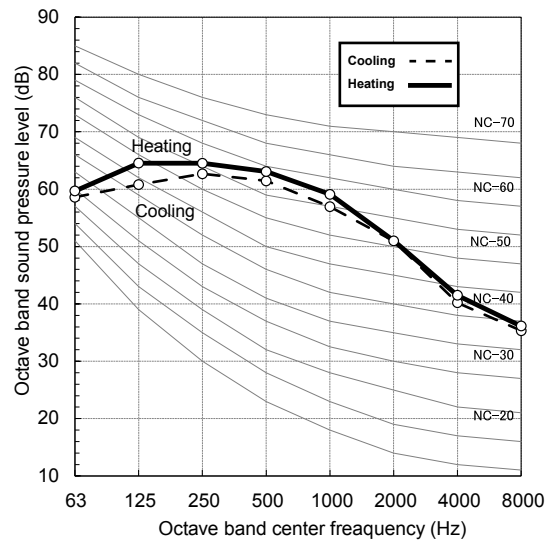
MMY-MAP1206FT8P-E

Sound pressure Level (dB(A))	Cooling	Heating
	60.0	62.0



MMY-MAP1406FT8P-E

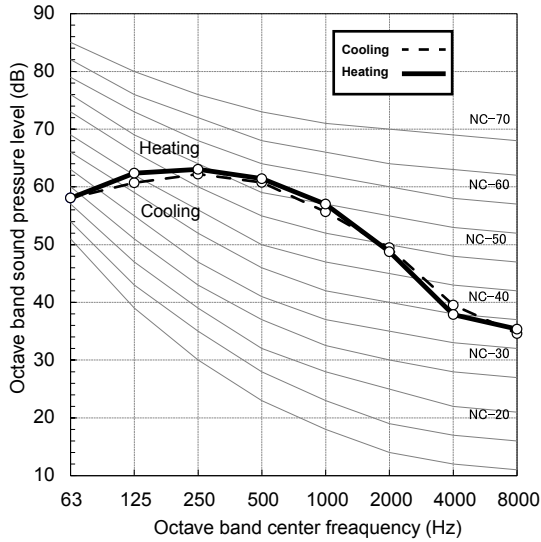
Sound pressure Level (dB(A))	Cooling	Heating
	62.0	64.0





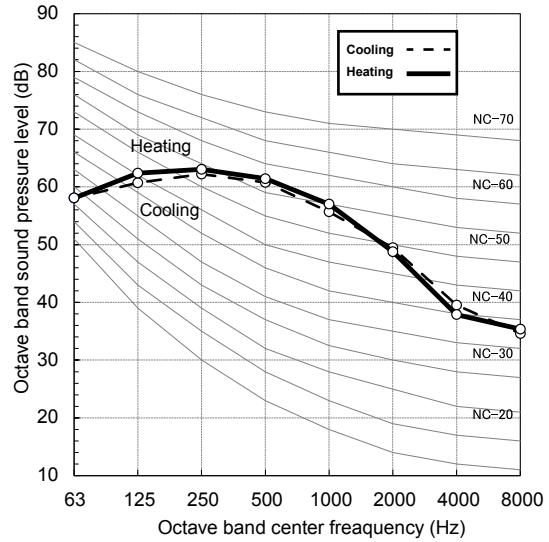
MMY-MAP1604FT8P-E

Sound pressure Level (dB(A))	Cooling	Heating
	61.0	62.0



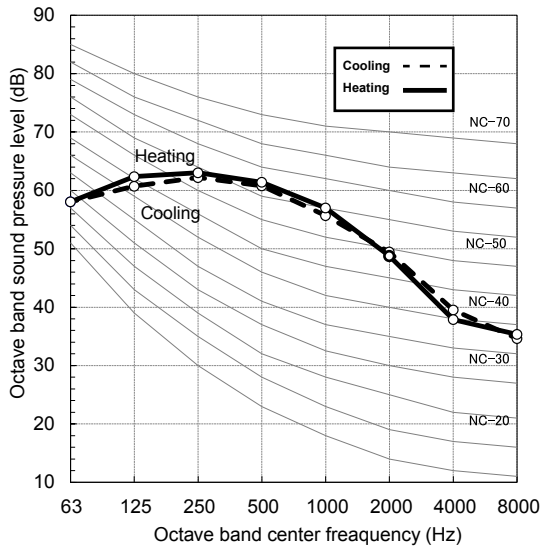
MMY-MAP1806FT8P-E

Sound pressure Level (dB(A))	Cooling	Heating
	61.0	62.0



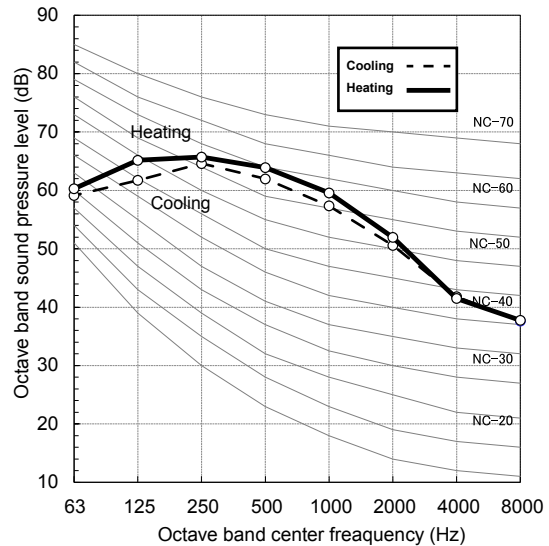
MMY-MAP2006FT8P-E

Sound pressure Level (dB(A))	Cooling	Heating
	61.0	62.0



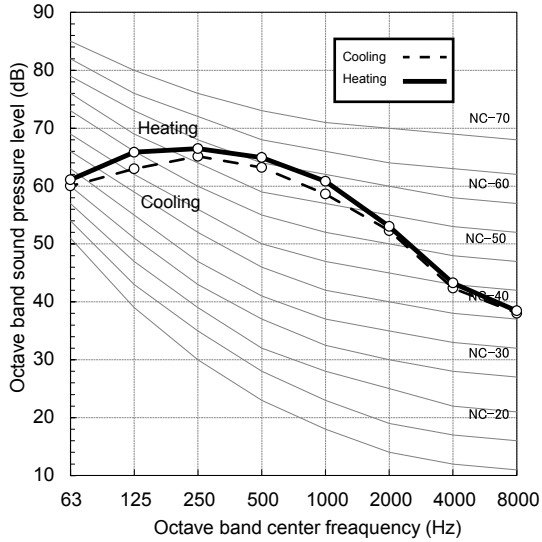
MMY-AP2206FT8P-E

Sound pressure Level (dB(A))	Cooling	Heating
	62.5	64.5



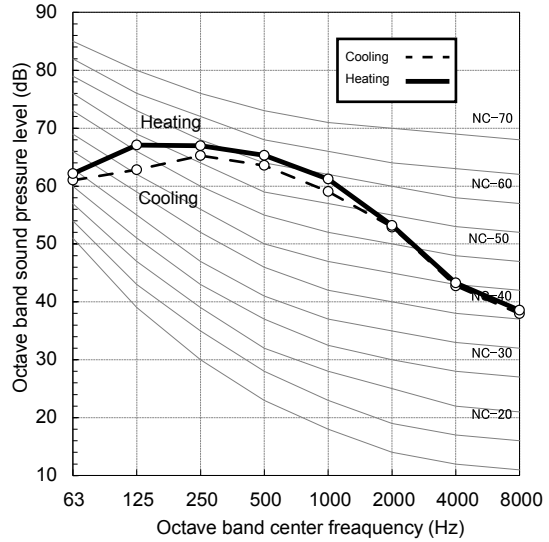
MMY-AP2416FT8P-E

Sound pressure Level (dB(A))	Cooling	Heating
	64.0	66.0



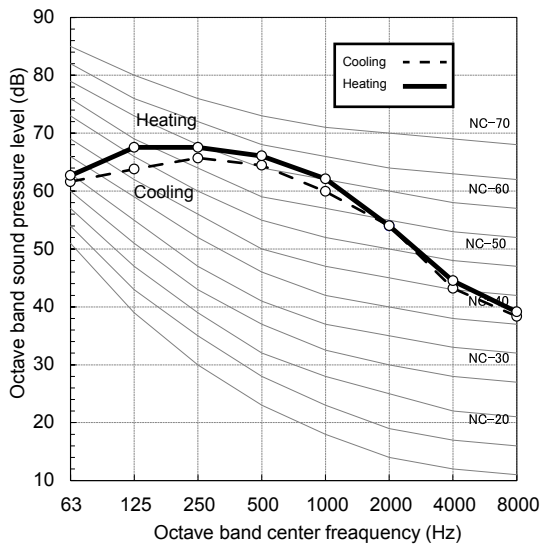
MMY-AP2616FT8P-E

Sound pressure Level (dB(A))	Cooling	Heating
	64.5	66.5



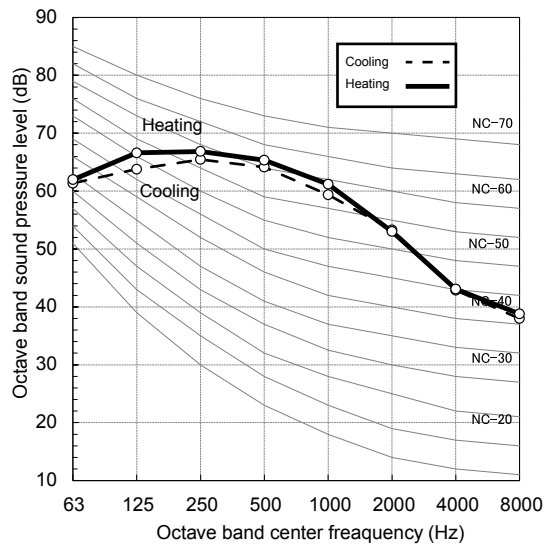
MMY-AP2816FT8P-E

Sound pressure Level (dB(A))	Cooling	Heating
	65.0	67.0



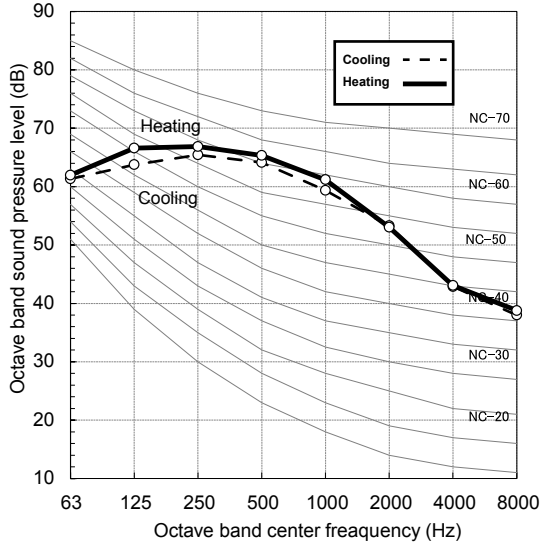
MMY-AP3016FT8P-E

Sound pressure Level (dB(A))	Cooling	Heating
	64.5	66.5



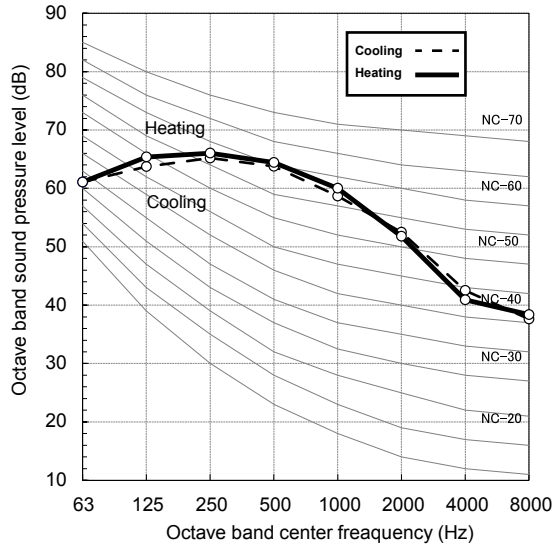
MMY-AP3216FT8P-E

Sound pressure Level (dB(A))	Cooling	Heating
	64.5	66.5



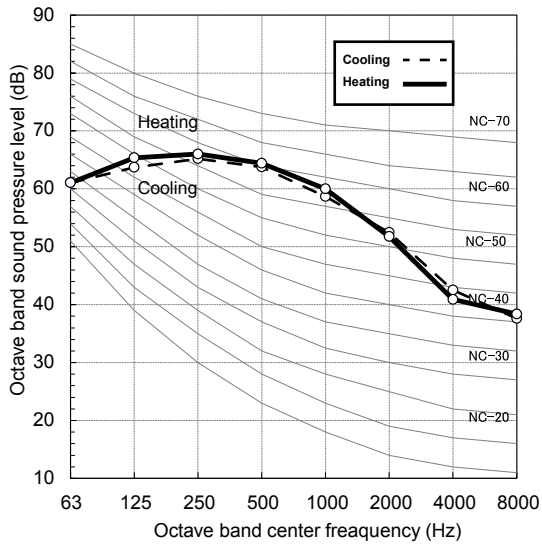
MMY-AP3416FT8P-E

Sound pressure Level (dB(A))	Cooling	Heating
	64.0	65.0



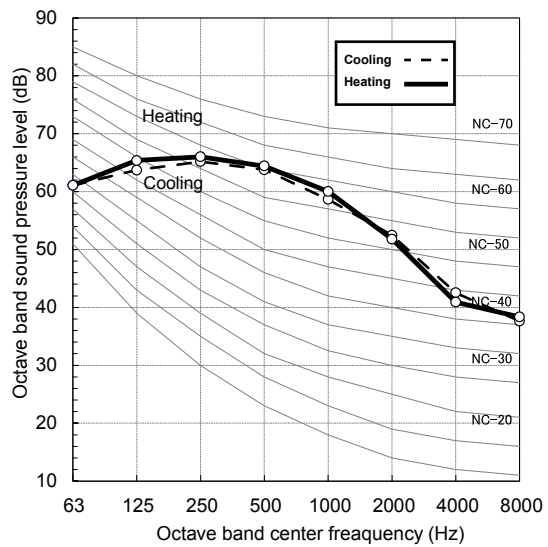
MMY-AP3616FT8P-E

Sound pressure Level (dB(A))	Cooling	Heating
	64.0	65.0



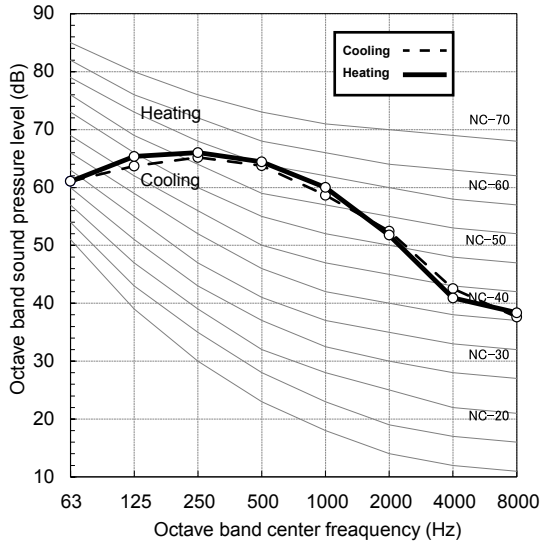
MMY-AP3816FT8P-E

Sound pressure Level (dB(A))	Cooling	Heating
	64.0	65.0



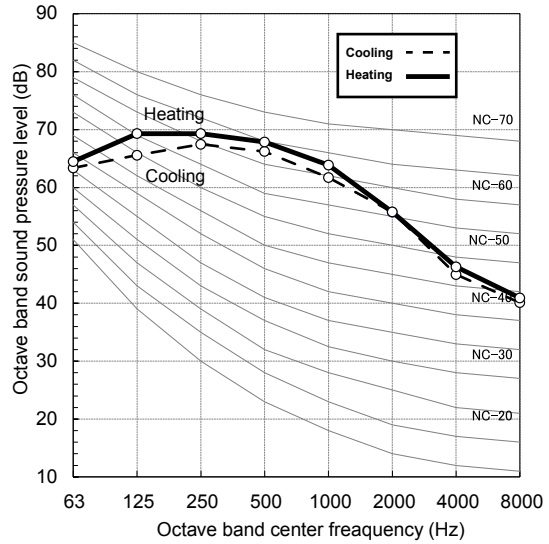
MMY-AP4016FT8P-E

Sound pressure Level (dB(A))	Cooling	Heating
	64.0	65.0



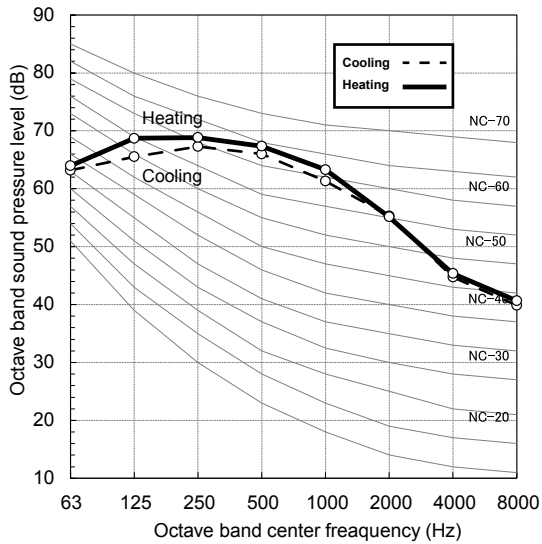
MMY-AP4216FT8P-E

Sound pressure Level (dB(A))	Cooling	Heating
	67.0	69.0



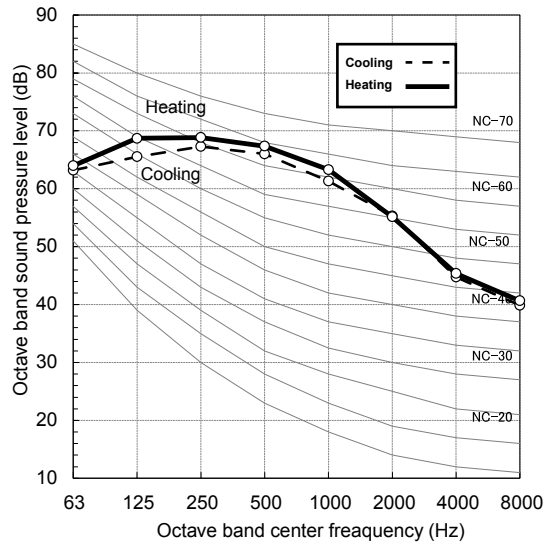
MMY-AP4416FT8P-E

Sound pressure Level (dB(A))	Cooling	Heating
	66.5	68.5



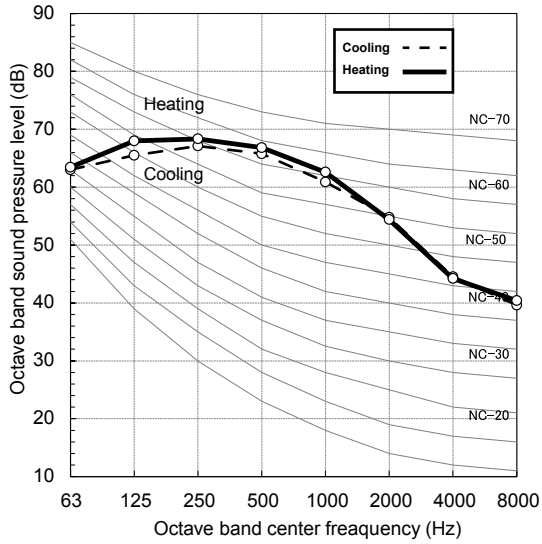
MMY-AP4616FT8P-E

Sound pressure Level (dB(A))	Cooling	Heating
	66.5	68.5



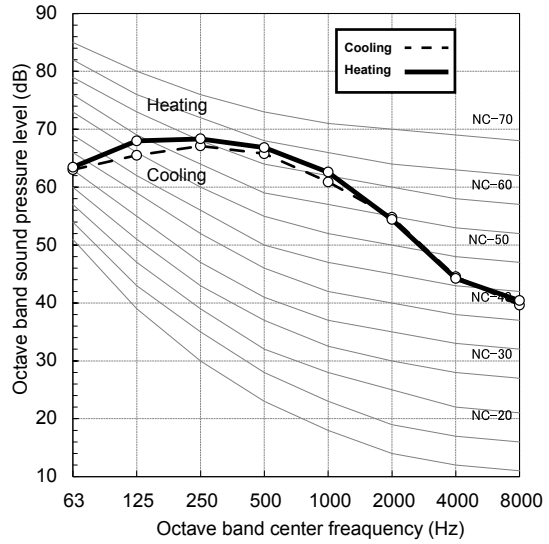
MMY-AP4816FT8P-E

Sound pressure Level (dB(A))	Cooling	Heating
	66.5	67.5



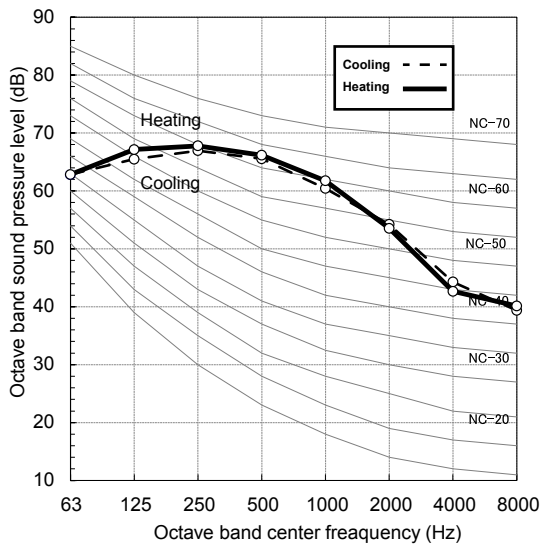
MMY-AP5016FT8P-E

Sound pressure Level (dB(A))	Cooling	Heating
	66.5	67.5



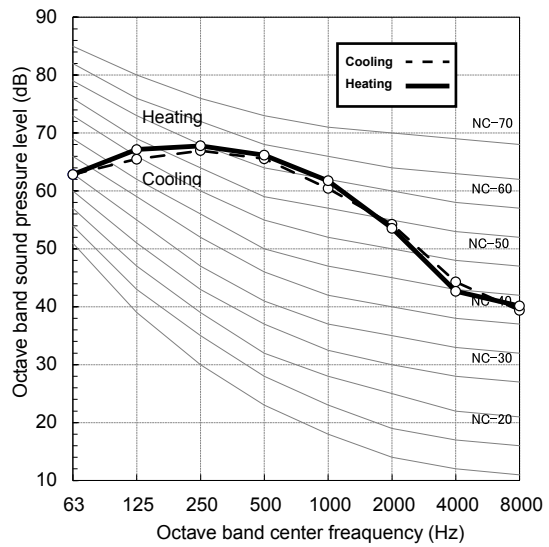
MMY-AP5216FT8P-E

Sound pressure Level (dB(A))	Cooling	Heating
	66.0	67.0



MMY-AP5416FT8P-E

Sound pressure Level (dB(A))	Cooling	Heating
	66.0	67.0



5-12. FS unit (Flow Selection unit)

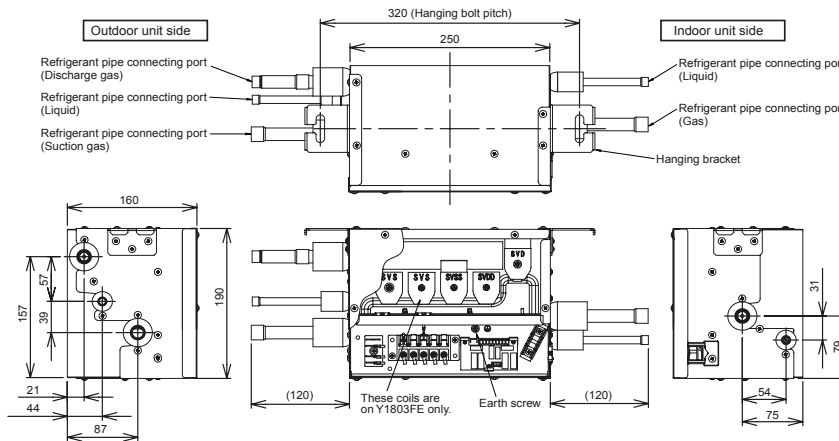
Specifications (Single)

Model Name	RBM-Y1123FE	RBM-Y1803FE	RBM-Y2803FE
Power supply	220/240 V 1 phase 50 Hz		
Connectable indoor unit capacity (kW/h)	Below 38	38 to below 18.0	18.0 to 96 or less
Connectable indoor units	5	8	8
Dimension	Height (mm)	190	200
	Width (mm)	248	400
	Depth (mm)	160	200
Total Weight (Kg)	5	6	9
Connecting port dia. (Indoor unit side)	Liquid side (mm)	Ø9.5	Ø9.5
	Gas side (mm)	Ø15.9	Ø15.9
			Ø22.2
Connecting port dia. (Outdoor unit side)	Liquid side (mm)	Ø9.5	Ø9.5
	Discharge gas side (mm)	Ø12.7	Ø12.7
	Suction gas side (mm)	Ø15.9	Ø15.9
Connection	Blaze connection		

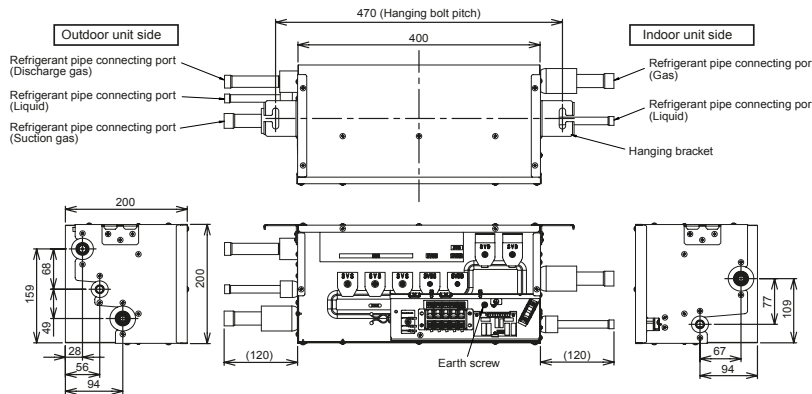
External view (Single)

RBM-Y1123FE, RBM-Y1803FE

(Unit: mm)

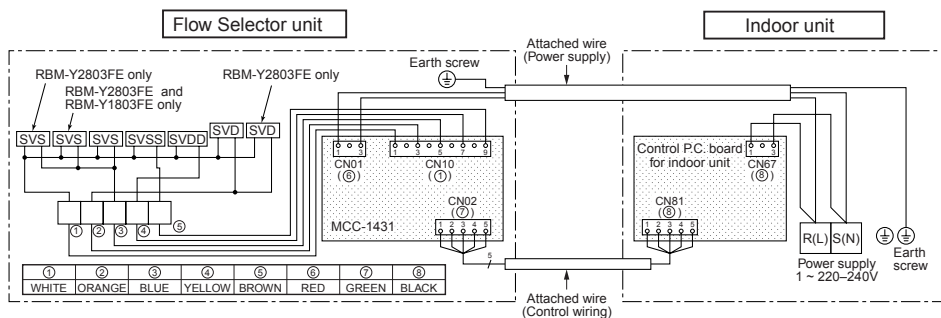


RBM-Y2803FE

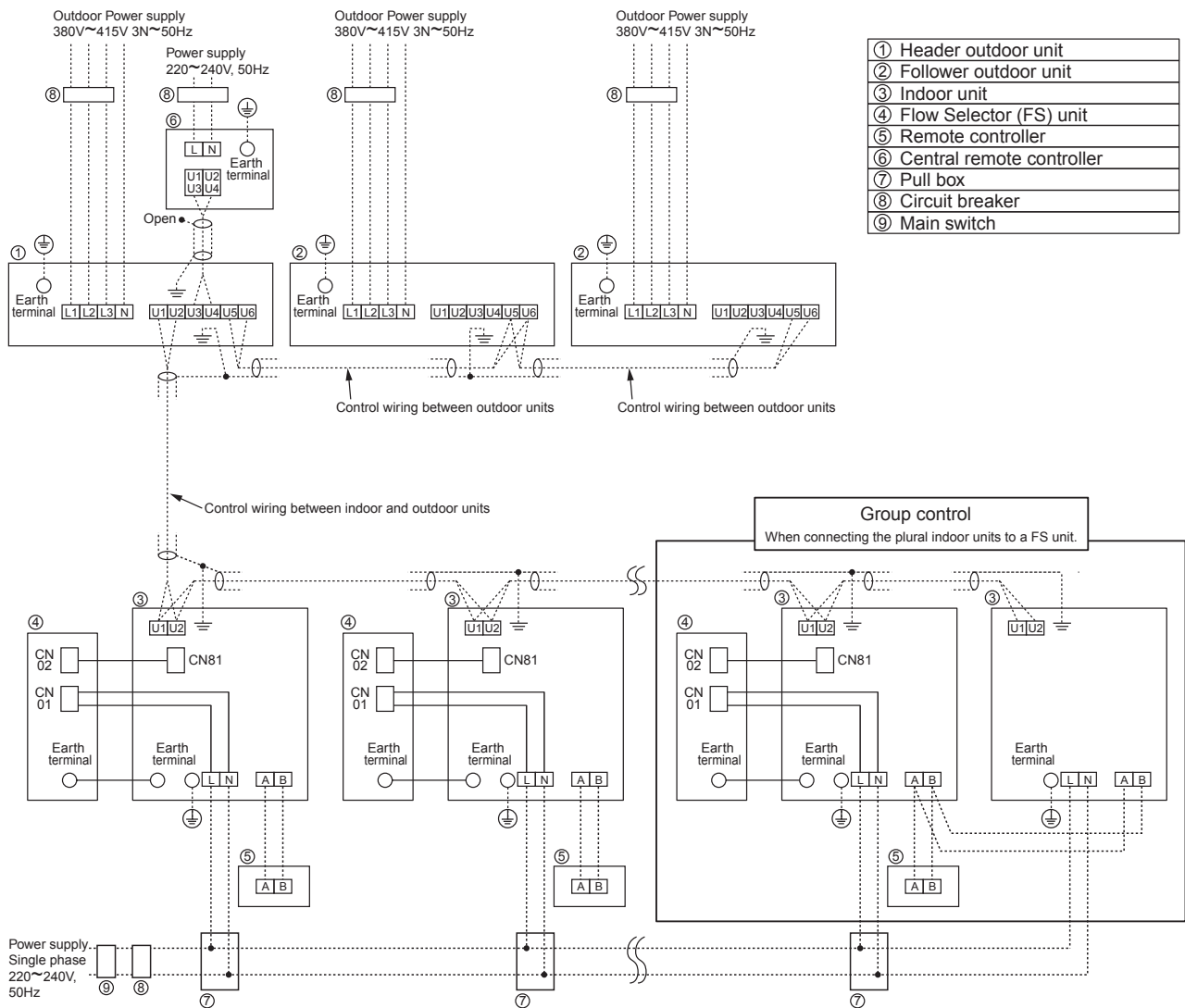


Wiring Diagram (Single)

RBM-Y1123FE, RBM-Y1803FE / RBM-Y2803FE



System wiring diagram (Single)



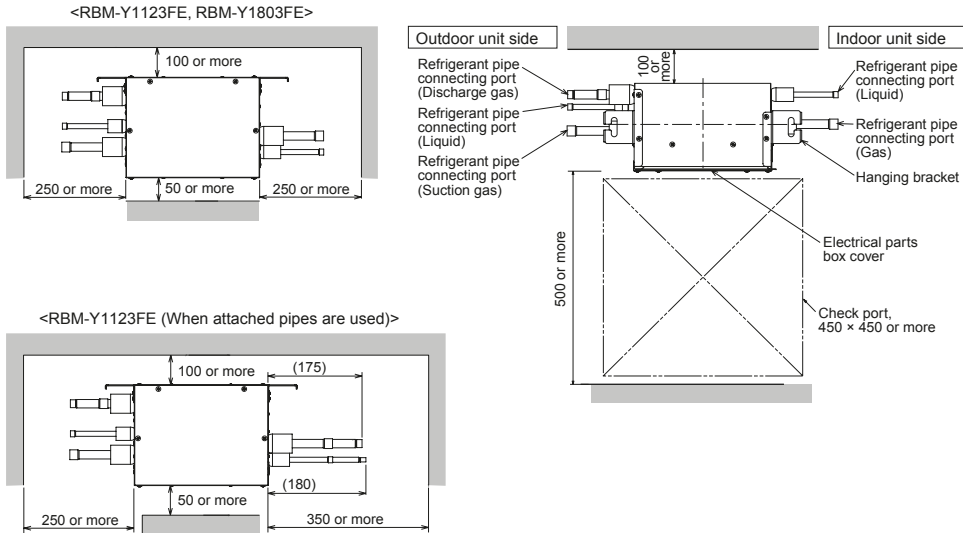
NOTE :

Control wire and power wire between FS unit and indoor unit are the accessory parts of FS unit. (Wire length : 6m)
 If the length between indoor and FS unit exceeds 5m, connect by using the connection cable kit sold separately (RBC-CBK15FE).

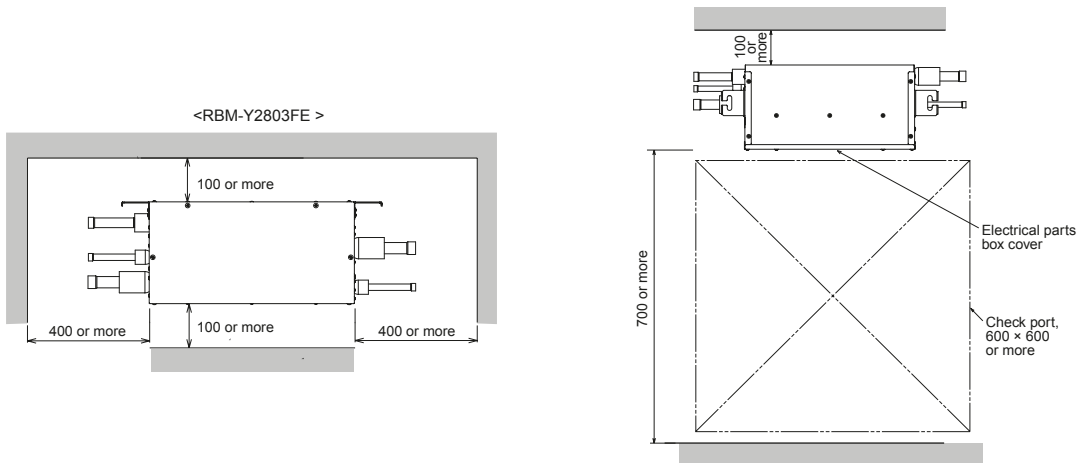
Installation space (Single)

(Unit : mm)

RBM-Y1123FE, RBM-Y1803FE

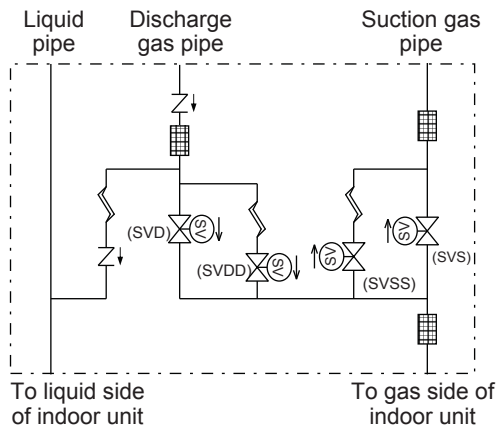


RBM-Y2803FE

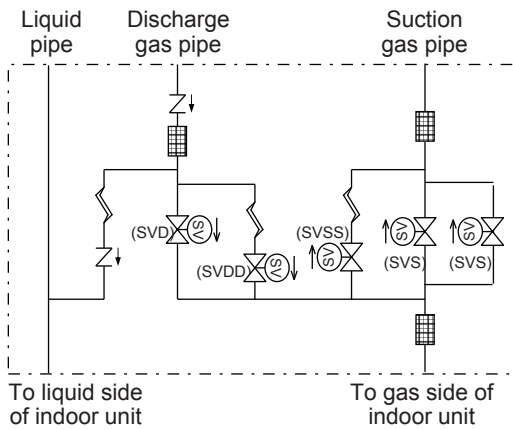


Refrigeration cycle diagram (Single)

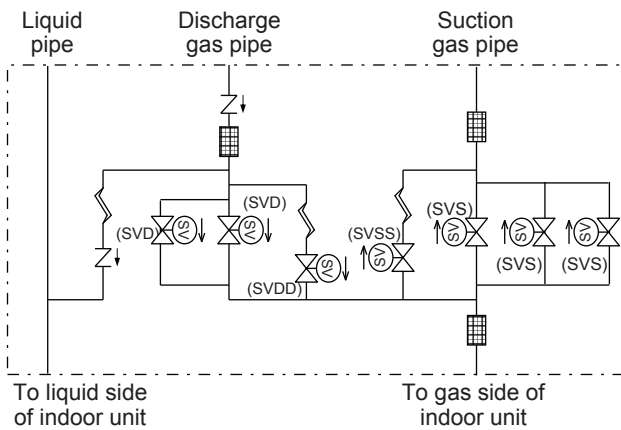
Model RBM-Y1123FE



Model RBM-Y1803FE



Model RBM-Y2803FE



Symbol				
	Solenoid Valve	Capillary Tube	Check Valve	Strainer

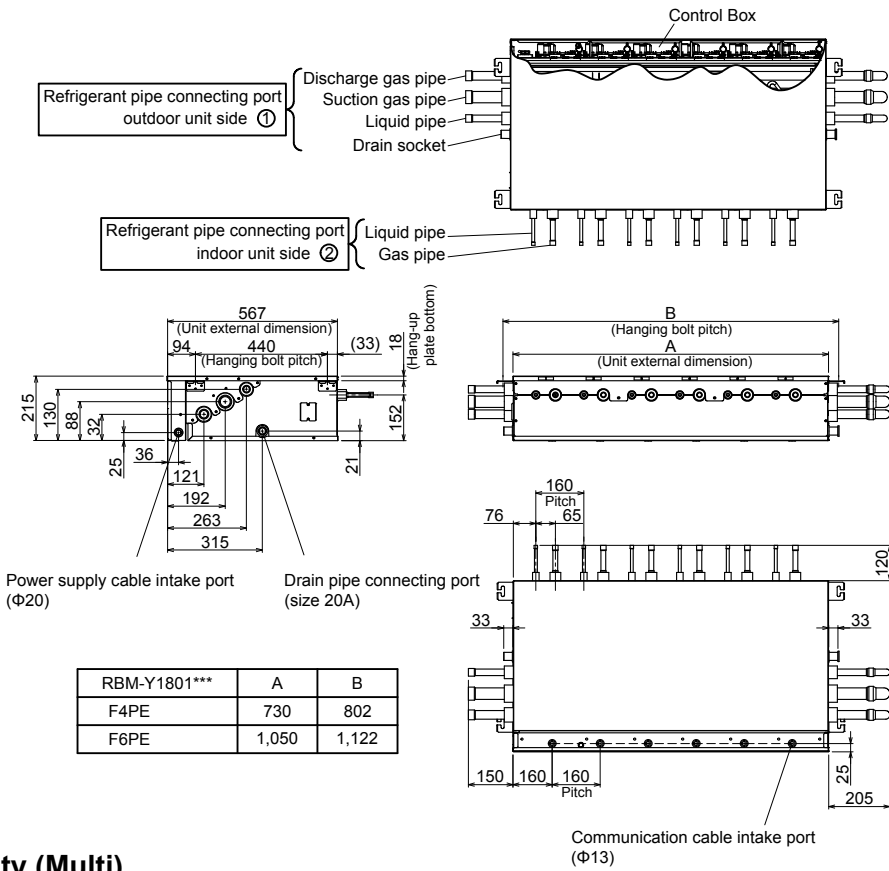
Specifications (Multi)

Model Name		RBM-Y1801F4PE	RBM-Y1801F6PE
Power supply		220-240V 1 phase 50 Hz	
Connectable indoor unit capacity (kW/h)		Below 18.0	
Dimension	Height (mm)	215	215
	Width (mm)	730	1,050
	Depth (mm)	567	567
Total Weight (Kg)		38	53
Connecting port dia. (Indoor unit side)	Liquid side (mm)	Ø9.5	Ø9.5
	Gas side (mm)	Ø15.9	Ø15.9
Connecting port dia. (Outdoor unit side)	Liquid side (mm)	Ø22.2	Ø22.2
	Discharge gas side (mm)	Ø28.6	Ø28.6
	Suction gas side (mm)	Ø38.1	Ø38.1
Connection		Blaze connection	

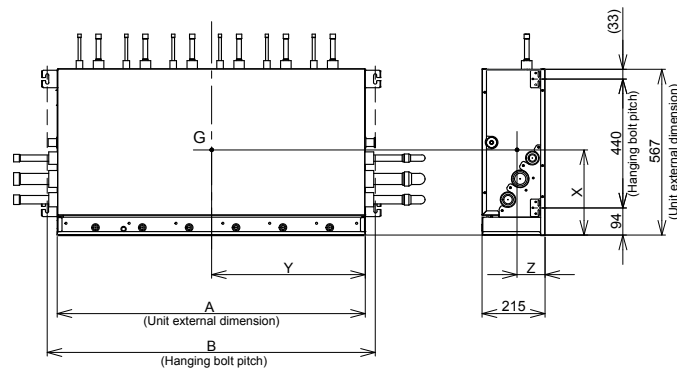
External view (Multi)

RBM-Y1801F4PE, RBM-Y801F6PE

(unit : mm)



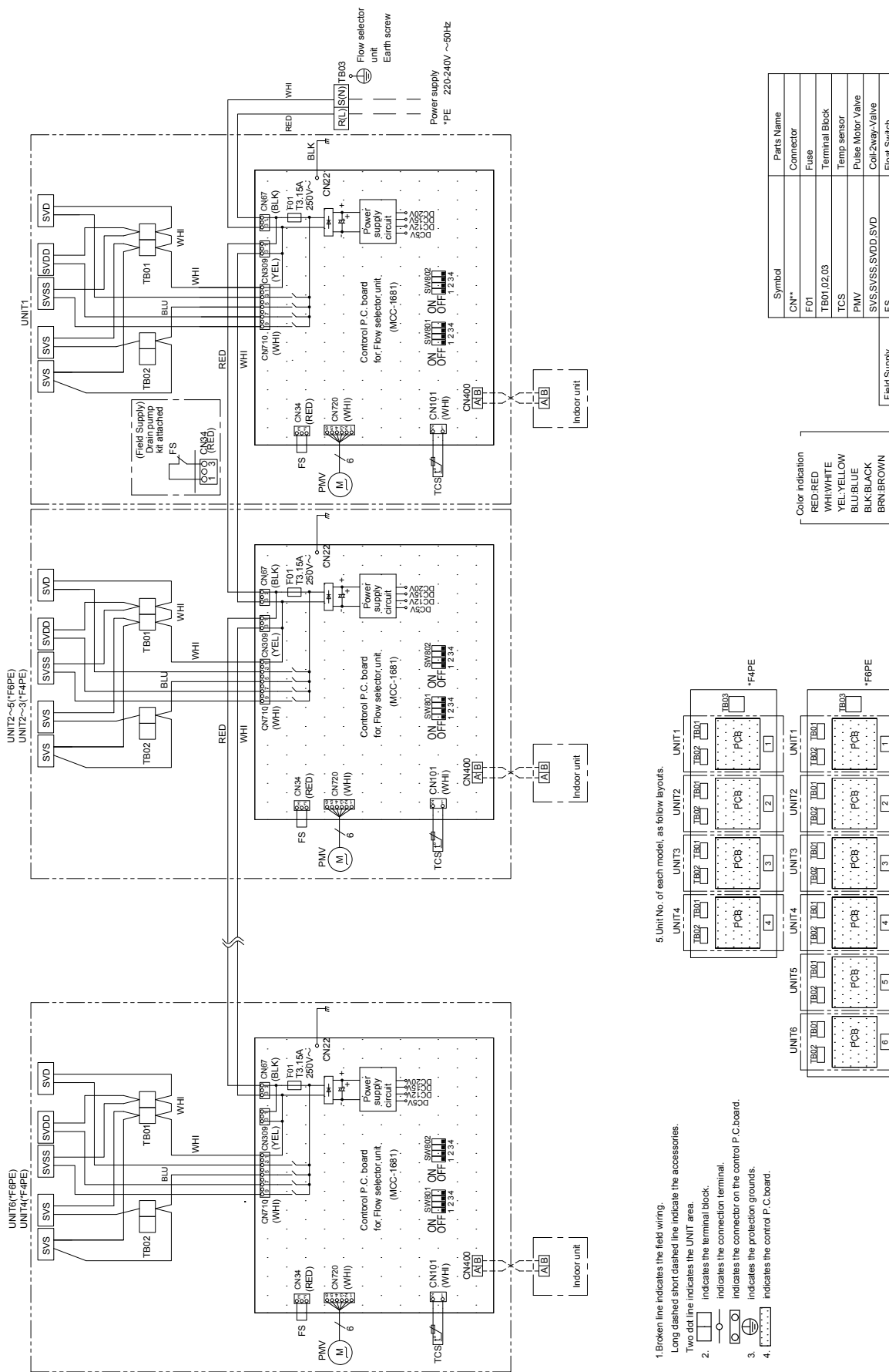
Center of gravity (Multi)



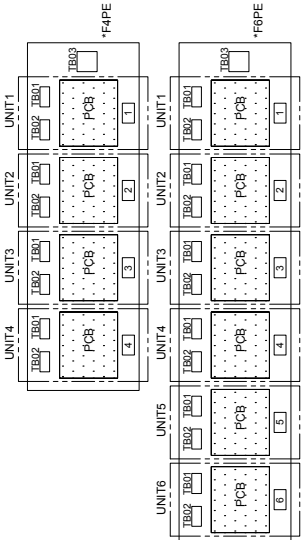
RBM-Y1801***	A (mm)	B (mm)	X (mm)	Y (mm)	Z (mm)	Weight (kg)
F4PE/F4PE2	730	802	293	365	96	38
F6PE/F6PE2	1,050	1,122	293	525	96	53



System wiring diagram (Multi)



5. Unit No. of each model, as follow layouts.

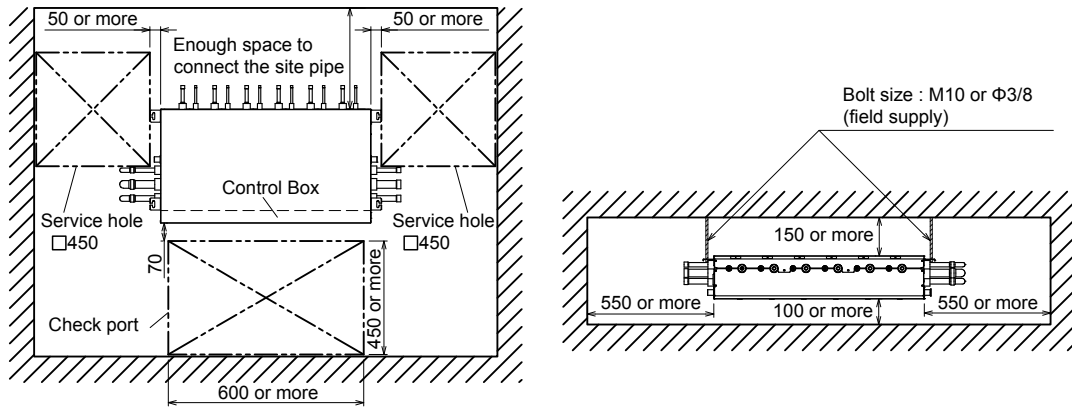


1. Broken line indicates the field wiring.
2. Long dashed short dashed line indicate the accessories.
3. Two dot line indicates the UNIT area.
4. [Symbol] indicates the terminal block.
5. [Symbol] indicates the connection terminal.
6. [Symbol] indicates the connector on the control P.C. board.
7. [Symbol] indicates the protection grounds.
8. [Symbol] indicates the control P.C. board.

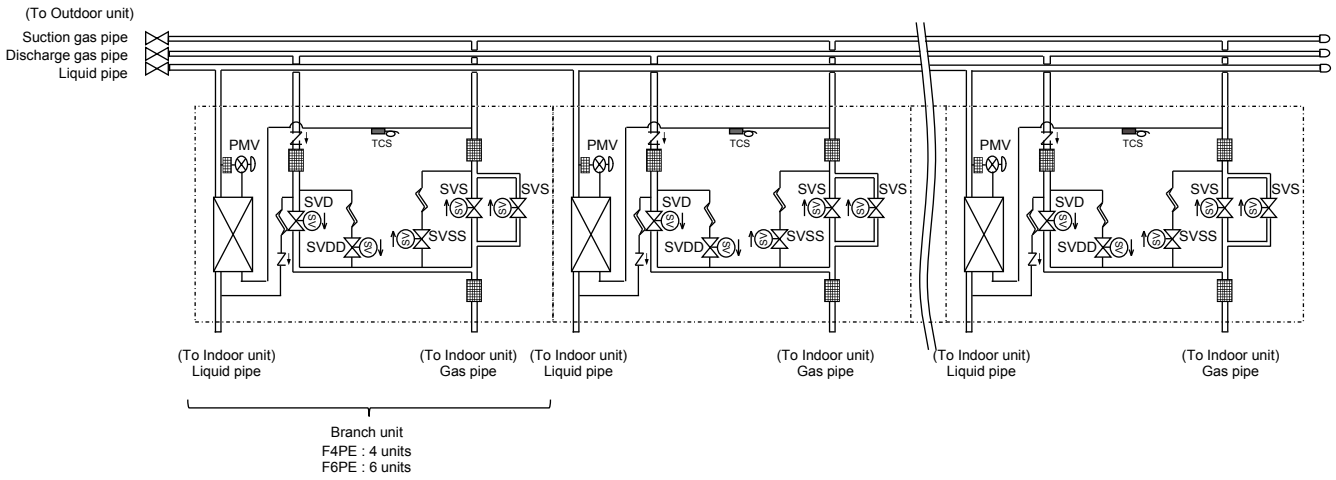
Symbol	Parts Name
CN*	Connector
F01	Fuse
TBO1,02,03	Terminal Block
TCS	Temp sensor
PMV	Pulse Motor Valve
SVS,SVSS,SVDD,SVL	Coil-2way-Valve
FS	Float Switch

Color indication
RED:RED
WHI:WHITE
YEL:YELLOW
BLU:BLUE
BLK:BLACK
BRN:BROWN

Installation space (Multi)



Refrigeration cycle diagram (Multi)



Symbol					
	Solenoide Valve	Capillary Tube	Check Valve	Strainer	Stop

SHRM-e Engineering Data Book

Model name:

MMY-MAP_6FT8P-E

May, 2016 Full version