

11-2-7. Slim Duct Type

Slim Duct Type

Indoor Unit

MMD-AP0074SPH-E
MMD-AP0094SPH-E
MMD-AP0124SPH-E
MMD-AP0154SPH-E
MMD-AP0184SPH-E



Contents

1. Specifications
2. Dimension
3. Wiring diagram
4. Center of Gravity
5. Electrical characteristics
6. Sensible capacity table
7. Fan characteristics
8. Sound characteristics (NC-Curve)
9. Fresh air intake (Design guide)
10. Accessories

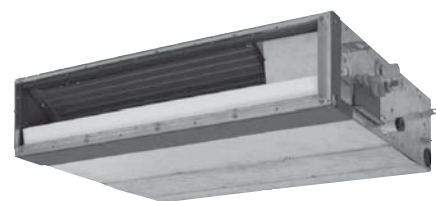

1. Specification

50Hz

Model name		MMD-	AP0074SPH-E	AP0094SPH-E	AP0124SPH-E	AP0154SPH-E	AP0184SPH-E	
Cooling/Heating capacity (Note 1) (kW)			2.2/2.5	2.8/3.2	3.6/4.0	4.5/5.0	5.6/6.3	
Electrical characteristics	Power supply	1 phase 50Hz 230V (220-240V)						
	Running current (A)		0.29	0.29	0.31	0.32	0.39	
	Power consumption (kW)		0.039	0.039	0.043	0.045	0.054	
	Starting current (A)		0.51	0.51	0.54	0.56	0.68	
Appearance		Zinc hot dipping steel plate						
Dimension	Height (mm)	210						
	Width (mm)	845						
	Depth (mm)	645						
Total weight (kg)			22	22	22	23	23	
Heat exchanger		Finned tube						
Soundproof / Heat-insulating material		Polyethylene foam + Polyurethane foam						
Fan		Centrifugal fan (Sirocco fan)						
Standard air flow	High (m³/h)		540		600	690	780	
	(Mid./Low) (m³/h)		470/400		520/450	600/520	680/580	
Motor output (W)		60						
External static pressure (Pa)			6 (Factory setting) -16-31-46 4steps		5 (Factory setting) -15-30-45 4steps		4 (Factory setting) -14-29-44 4steps	
	Air filter pressure loss (Pa)		4		5		6	
Controller		Remote controller						
Air filter		Standard filter supplied (Long life filter)						
Connecting pipe	Gas pipe (mm)		Φ9.5			Φ12.7		
	Liquid pipe (mm)		Φ6.4					
	Drain pipe (Nominal dia.mm)	25 (Polyvinyl chloride tube : External dia.32 Internal dia.25)						
Sound pressure level (Note 2) High/Mid./Low	Under air inlet (dB(A))		36/33/30		38/35/32	39/36/33	40/38/36	
	Back air inlet (dB(A))		28/26/24		29/27/25	32/30/28	33/31/29	

Note 1 : The cooling capacities and electrical characteristics are measured under the conditions specified by JIS B 8615 based on the reference piping.

The reference piping consists of 5 m of main piping and 2.5 m of branch piping connected with 0 meter height.

Note 2 : The sound level are measured in an anechoic chamber in accordance with JIS B 8616.

Normally, the values measured in the actual operating environment become larger than the indicated values due to the effects of external sound.

Note : Reted conditions Cooling: Indoor air temperature 27°C DB/19°C WB, Outdoor air temperature 35°C DB
Heating: Indoor air temperature 20°C DB, Outdoor air temperature 7°C DB/6°C WB

2. Dimensions

MMD-AP0074SPH-E, AP0094SPH-E, AP0124SPH-E, AP0154SPH-E, AP0184SPH-E

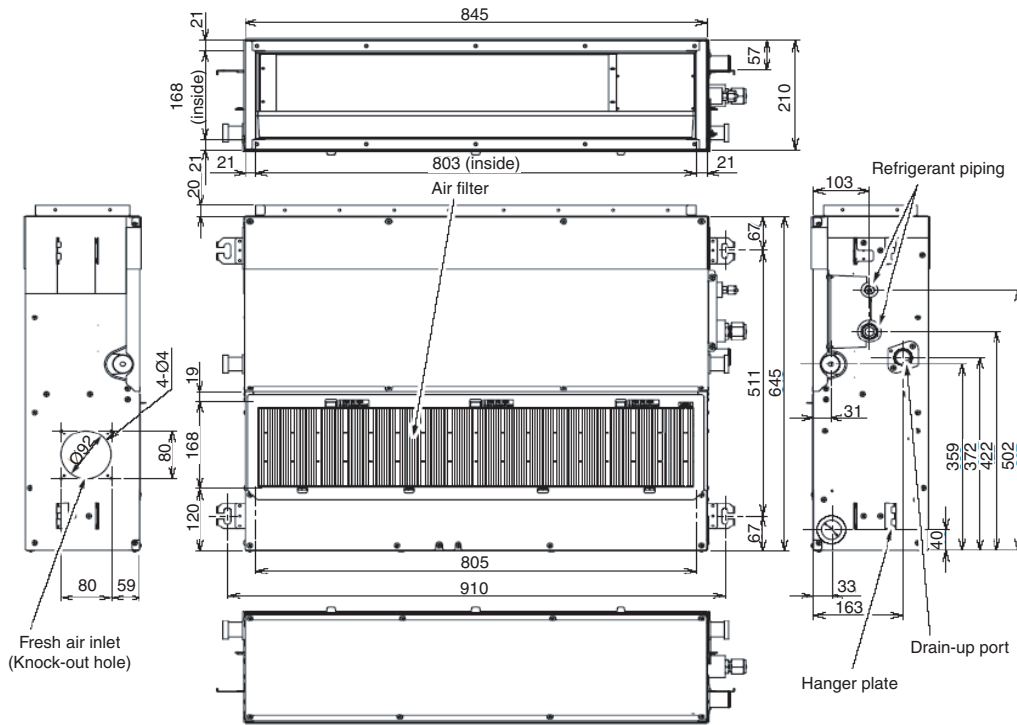

Air inlet connecting flange (Field supply)

Underside

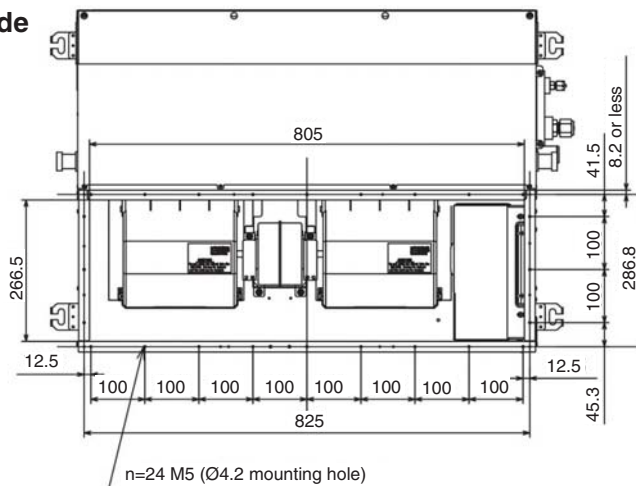

Rearside

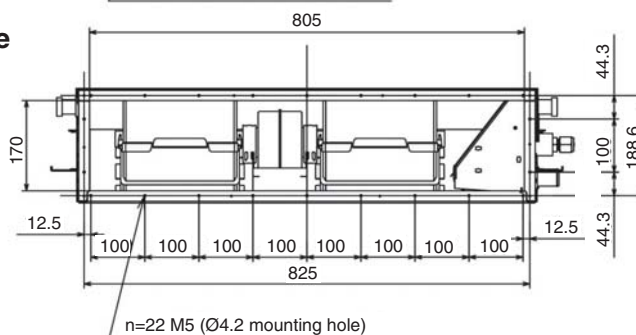

Installation space

(length:mm)

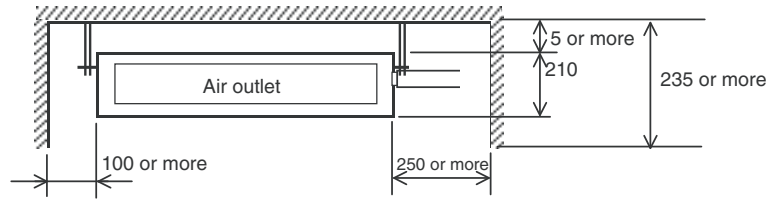

Under air inlet

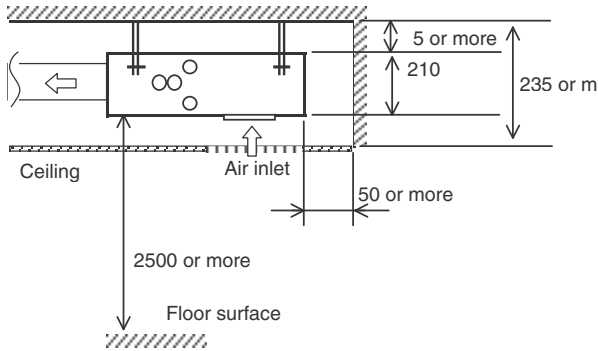

Rear air inlet

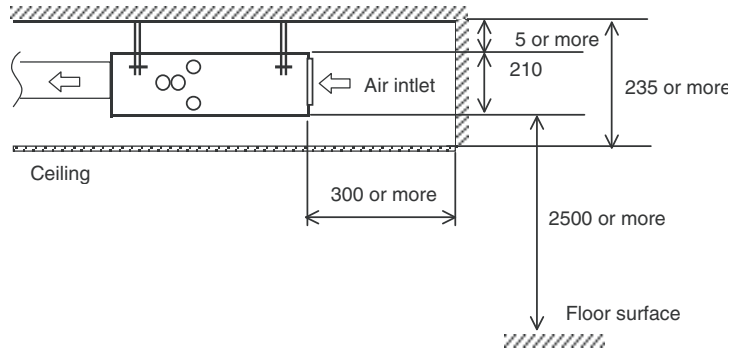

Service space

(length:mm)

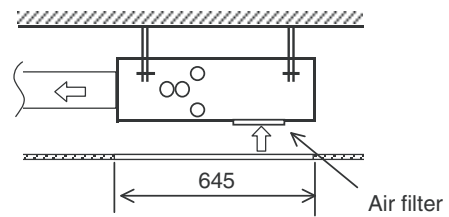
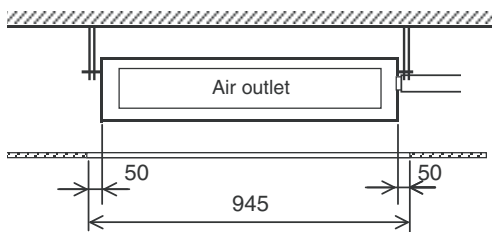

Service door (Ceiling opening)

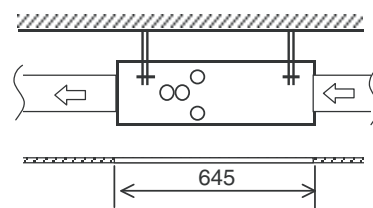
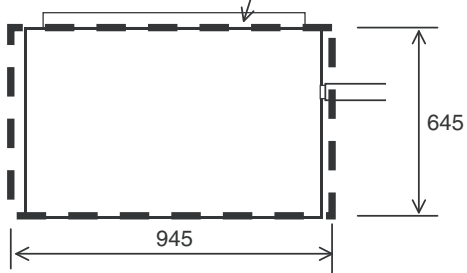

Service door (Ceiling opening)

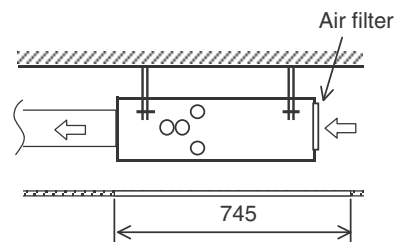
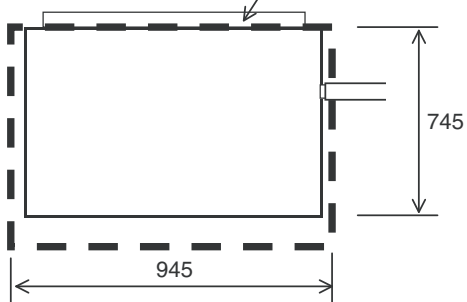



3. Wiring diagram

MMD-AP0074SPH-E, AP0094SPH-E, AP0124SPH-E, AP0154SPH-E, AP0184SPH-E

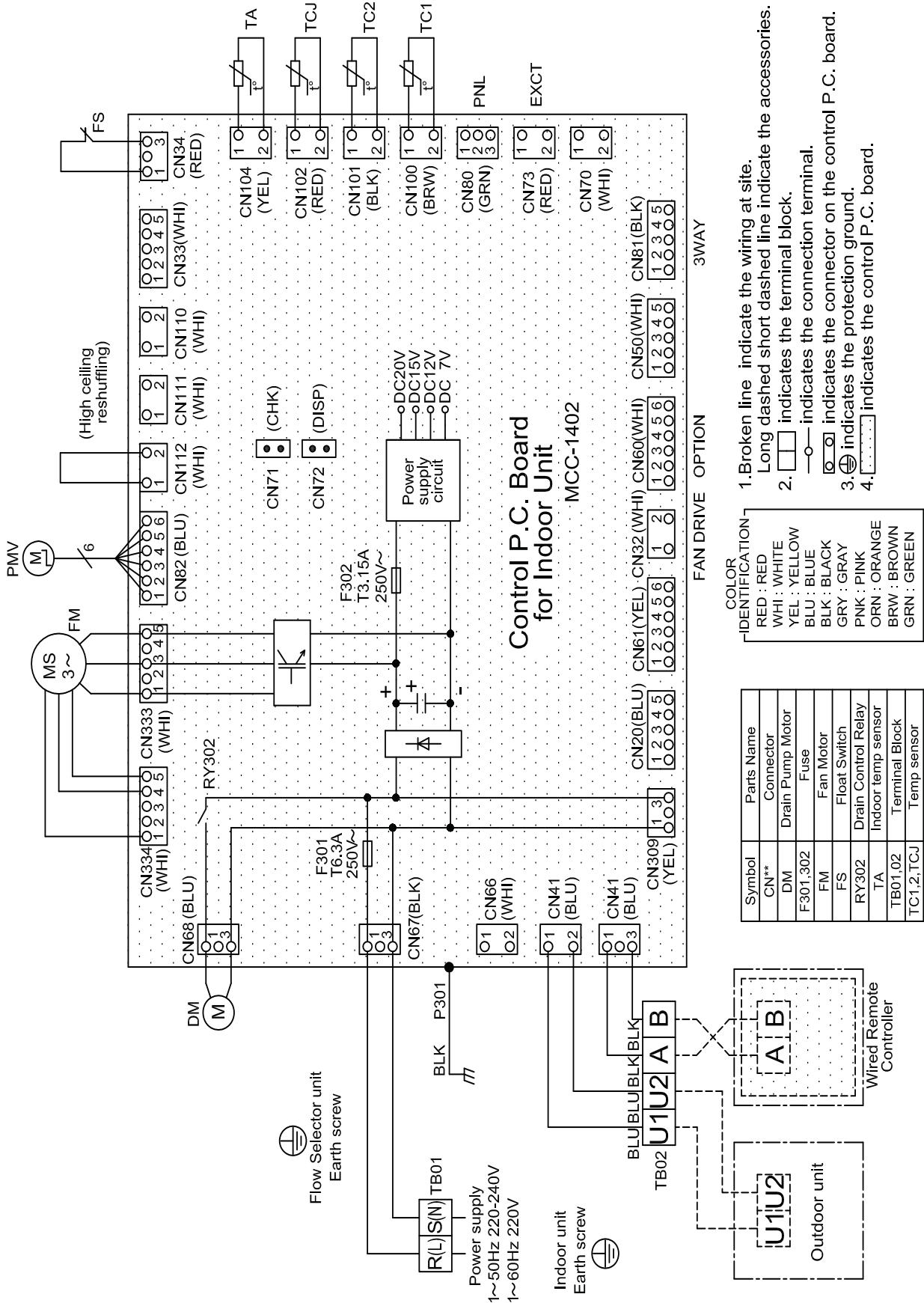

4. Center of Gravity

Model name	X (mm)	Y (mm)	Z (mm)	Total weight(kg)
MMD-AP0074SPH-E	315	470	110	22
MMD-AP0094SPH-E				
MMD-AP0124SPH-E				
MMD-AP0154SPH-E	320	460	110	23
MMD-AP0184SPH-E				

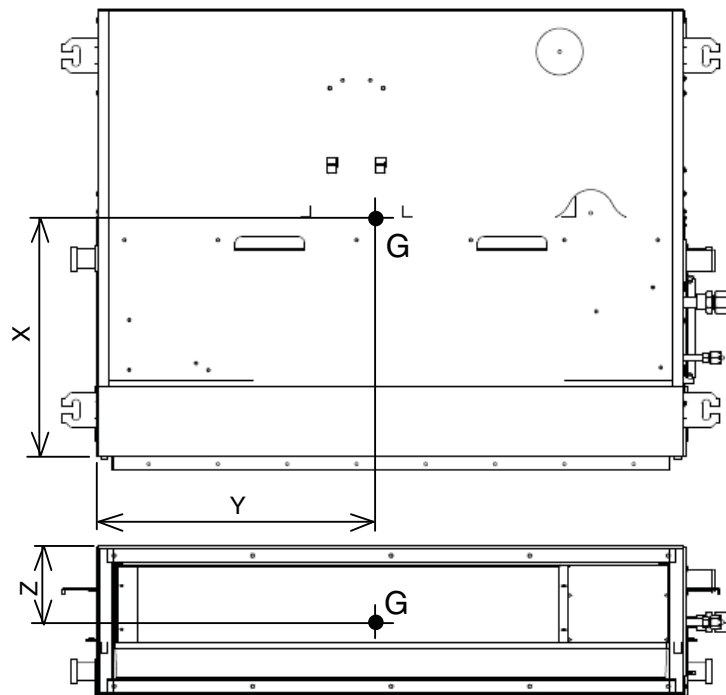

5. Electrical characteristics

Model	Nominal Voltage (V-Ph-Hz)	Voltage Range		Fan Motor		Power Supply	
		Min	Max	kW	FLA	MCA	MOCP
MMD-AP0074SPH-E	230-1-50	198	264	0.060	0.35	0.44	15
MMD-AP0094SPH-E	230-1-50	198	264	0.060	0.35	0.44	15
MMD-AP0124SPH-E	230-1-50	198	264	0.060	0.37	0.47	15
MMD-AP0154SPH-E	230-1-50	198	264	0.060	0.38	0.48	15
MMD-AP0184SPH-E	230-1-50	198	264	0.060	0.47	0.59	15

MCA : Minimum Circuit Amps FLA : Full Load Amps
 MOCP : Maximum Overcurrent Protection (Amps)



6. Sensible capacity table

■ Slim Duct Type (MMD-AP***4SPH-E)

TC : Total capacity [kW] SHC : Sensible capacity [kW]

Unit size	Outdoor air temp. CDB	Indoor air temp.													
		14.0CWB		16.0CWB		18.0CWB		19.0CWB		20.0CWB		22.0CWB		24.0CWB	
		20CDB		23CDB		26CDB		27CDB		28CDB		30CDB		32CDB	
		TC	SHC	TC	SHC	TC	SHC	TC	SHC	TC	SHC	TC	SHC	TC	SHC
007	10.0	1.8	1.6	2.0	1.7	2.1	1.8	2.2	1.8	2.3	1.8	2.4	1.8	2.5	1.7
	12.0	1.8	1.6	2.0	1.7	2.1	1.8	2.2	1.8	2.3	1.8	2.4	1.8	2.5	1.7
	14.0	1.8	1.6	2.0	1.7	2.1	1.8	2.2	1.8	2.3	1.8	2.4	1.8	2.5	1.7
	16.0	1.8	1.6	2.0	1.7	2.1	1.8	2.2	1.8	2.3	1.8	2.4	1.8	2.5	1.7
	18.0	1.8	1.6	2.0	1.7	2.1	1.8	2.2	1.8	2.3	1.8	2.4	1.8	2.5	1.7
	20.0	1.8	1.6	2.0	1.7	2.1	1.8	2.2	1.8	2.3	1.8	2.4	1.8	2.5	1.7
	21.0	1.8	1.6	2.0	1.7	2.1	1.8	2.2	1.8	2.3	1.8	2.4	1.8	2.5	1.7
	23.0	1.8	1.6	2.0	1.7	2.1	1.8	2.2	1.8	2.3	1.8	2.4	1.8	2.5	1.7
	25.0	1.8	1.6	2.0	1.7	2.1	1.8	2.2	1.8	2.3	1.8	2.4	1.8	2.5	1.7
	27.0	1.8	1.6	2.0	1.7	2.1	1.8	2.2	1.8	2.3	1.8	2.4	1.8	2.5	1.7
	29.0	1.8	1.6	2.0	1.7	2.1	1.8	2.2	1.8	2.3	1.8	2.4	1.8	2.5	1.7
	31.0	1.8	1.6	2.0	1.7	2.1	1.8	2.2	1.8	2.3	1.8	2.4	1.8	2.5	1.7
	33.0	1.8	1.6	2.0	1.7	2.1	1.8	2.2	1.8	2.3	1.8	2.4	1.8	2.5	1.7
35.0	1.8	1.6	2.0	1.7	2.1	1.8	2.2	1.8	2.3	1.8	2.4	1.8	2.5	1.7	
37.0	1.7	1.5	1.9	1.6	2.1	1.7	2.1	1.7	2.2	1.7	2.3	1.7	2.4	1.7	
39.0	1.7	1.5	1.9	1.6	2.0	1.7	2.1	1.7	2.1	1.7	2.3	1.7	2.4	1.6	
009	10.0	2.3	1.9	2.5	2.0	2.7	2.1	2.8	2.1	2.9	2.1	3.1	2.1	3.2	2.0
	12.0	2.3	1.9	2.5	2.0	2.7	2.1	2.8	2.1	2.9	2.1	3.1	2.1	3.2	2.0
	14.0	2.3	1.9	2.5	2.0	2.7	2.1	2.8	2.1	2.9	2.1	3.1	2.1	3.2	2.0
	16.0	2.3	1.9	2.5	2.0	2.7	2.1	2.8	2.1	2.9	2.1	3.1	2.1	3.2	2.0
	18.0	2.3	1.9	2.5	2.0	2.7	2.1	2.8	2.1	2.9	2.1	3.1	2.1	3.2	2.0
	20.0	2.3	1.9	2.5	2.0	2.7	2.1	2.8	2.1	2.9	2.1	3.1	2.1	3.2	2.0
	21.0	2.3	1.9	2.5	2.0	2.7	2.1	2.8	2.1	2.9	2.1	3.1	2.1	3.2	2.0
	23.0	2.3	1.9	2.5	2.0	2.7	2.1	2.8	2.1	2.9	2.1	3.1	2.1	3.2	2.0
	25.0	2.3	1.9	2.5	2.0	2.7	2.1	2.8	2.1	2.9	2.1	3.1	2.1	3.2	2.0
	27.0	2.3	1.9	2.5	2.0	2.7	2.1	2.8	2.1	2.9	2.1	3.1	2.1	3.2	2.0
	29.0	2.3	1.9	2.5	2.0	2.7	2.1	2.8	2.1	2.9	2.1	3.1	2.1	3.2	2.0
	31.0	2.3	1.9	2.5	2.0	2.7	2.1	2.8	2.1	2.9	2.1	3.1	2.1	3.2	2.0
	33.0	2.3	1.9	2.5	2.0	2.7	2.1	2.8	2.1	2.9	2.1	3.1	2.1	3.2	2.0
35.0	2.3	1.9	2.5	2.0	2.7	2.1	2.8	2.1	2.9	2.1	3.1	2.1	3.2	2.0	
37.0	2.2	1.8	2.5	1.9	2.6	2.0	2.7	2.0	2.8	2.0	3.0	2.0	3.1	2.0	
39.0	2.2	1.8	2.4	1.9	2.6	2.0	2.6	2.0	2.7	2.0	2.9	2.0	3.0	1.9	
012	10.0	3.0	2.2	3.3	2.4	3.5	2.5	3.6	2.5	3.7	2.5	3.9	2.5	4.1	2.4
	12.0	3.0	2.2	3.3	2.4	3.5	2.5	3.6	2.5	3.7	2.5	3.9	2.5	4.1	2.4
	14.0	3.0	2.2	3.3	2.4	3.5	2.5	3.6	2.5	3.7	2.5	3.9	2.5	4.1	2.4
	16.0	3.0	2.2	3.3	2.4	3.5	2.5	3.6	2.5	3.7	2.5	3.9	2.5	4.1	2.4
	18.0	3.0	2.2	3.3	2.4	3.5	2.5	3.6	2.5	3.7	2.5	3.9	2.5	4.1	2.4
	20.0	3.0	2.2	3.3	2.4	3.5	2.5	3.6	2.5	3.7	2.5	3.9	2.5	4.1	2.4
	21.0	3.0	2.2	3.3	2.4	3.5	2.5	3.6	2.5	3.7	2.5	3.9	2.5	4.1	2.4
	23.0	3.0	2.2	3.3	2.4	3.5	2.5	3.6	2.5	3.7	2.5	3.9	2.5	4.1	2.4
	25.0	3.0	2.2	3.3	2.4	3.5	2.5	3.6	2.5	3.7	2.5	3.9	2.5	4.1	2.4
	27.0	3.0	2.2	3.3	2.4	3.5	2.5	3.6	2.5	3.7	2.5	3.9	2.5	4.1	2.4
	29.0	3.0	2.2	3.3	2.4	3.5	2.5	3.6	2.5	3.7	2.5	3.9	2.5	4.1	2.4
	31.0	3.0	2.2	3.3	2.4	3.5	2.5	3.6	2.5	3.7	2.5	3.9	2.5	4.1	2.4
	33.0	3.0	2.2	3.3	2.4	3.5	2.5	3.6	2.5	3.7	2.5	3.9	2.5	4.1	2.4
35.0	3.0	2.2	3.3	2.4	3.5	2.5	3.6	2.5	3.7	2.5	3.9	2.5	4.1	2.4	
37.0	2.9	2.1	3.2	2.3	3.4	2.4	3.5	2.4	3.6	2.4	3.8	2.4	4.0	2.3	
39.0	2.8	2.1	3.1	2.2	3.3	2.4	3.4	2.4	3.5	2.4	3.7	2.3	3.9	2.3	



■ Slim Duct Type (MMD-AP*4SPH-E)**

TC : Total capacity [kW] SHC : Sensible capacity [kW]

Unit size	Outdoor air temp. CDB	Indoor air temp.													
		14.0CWB		16.0CWB		18.0CWB		19.0CWB		20.0CWB		22.0CWB		24.0CWB	
		20CDB		23CDB		26CDB		27CDB		28CDB		30CDB		32CDB	
		TC	SHC	TC	SHC	TC	SHC	TC	SHC	TC	SHC	TC	SHC	TC	SHC
015	10.0	3.7	2.8	4.1	3.0	4.4	3.2	4.5	3.2	4.6	3.2	4.9	3.2	5.1	3.1
	12.0	3.7	2.8	4.1	3.0	4.4	3.2	4.5	3.2	4.6	3.2	4.9	3.2	5.1	3.1
	14.0	3.7	2.8	4.1	3.0	4.4	3.2	4.5	3.2	4.6	3.2	4.9	3.2	5.1	3.1
	16.0	3.7	2.8	4.1	3.0	4.4	3.2	4.5	3.2	4.6	3.2	4.9	3.2	5.1	3.1
	18.0	3.7	2.8	4.1	3.0	4.4	3.2	4.5	3.2	4.6	3.2	4.9	3.2	5.1	3.1
	20.0	3.7	2.8	4.1	3.0	4.4	3.2	4.5	3.2	4.6	3.2	4.9	3.2	5.1	3.1
	21.0	3.7	2.8	4.1	3.0	4.4	3.2	4.5	3.2	4.6	3.2	4.9	3.2	5.1	3.1
	23.0	3.7	2.8	4.1	3.0	4.4	3.2	4.5	3.2	4.6	3.2	4.9	3.2	5.1	3.1
	25.0	3.7	2.8	4.1	3.0	4.4	3.2	4.5	3.2	4.6	3.2	4.9	3.2	5.1	3.1
	27.0	3.7	2.8	4.1	3.0	4.4	3.2	4.5	3.2	4.6	3.2	4.9	3.2	5.1	3.1
	29.0	3.7	2.8	4.1	3.0	4.4	3.2	4.5	3.2	4.6	3.2	4.9	3.2	5.1	3.1
	31.0	3.7	2.8	4.1	3.0	4.4	3.2	4.5	3.2	4.6	3.2	4.9	3.2	5.1	3.1
	33.0	3.7	2.8	4.1	3.0	4.4	3.2	4.5	3.2	4.6	3.2	4.9	3.2	5.1	3.1
	35.0	3.7	2.8	4.1	3.0	4.4	3.2	4.5	3.2	4.6	3.2	4.9	3.2	5.1	3.1
37.0	3.6	2.7	4.0	2.9	4.2	3.1	4.4	3.1	4.5	3.1	4.7	3.1	5.0	3.0	
39.0	3.5	2.7	3.8	2.8	4.1	3.0	4.2	3.0	4.4	3.0	4.6	3.0	4.8	2.9	
018	10.0	4.6	3.5	5.1	3.7	5.4	3.9	5.6	3.9	5.8	3.9	6.1	3.9	6.4	3.8
	12.0	4.6	3.5	5.1	3.7	5.4	3.9	5.6	3.9	5.8	3.9	6.1	3.9	6.4	3.8
	14.0	4.6	3.5	5.1	3.7	5.4	3.9	5.6	3.9	5.8	3.9	6.1	3.9	6.4	3.8
	16.0	4.6	3.5	5.1	3.7	5.4	3.9	5.6	3.9	5.8	3.9	6.1	3.9	6.4	3.8
	18.0	4.6	3.5	5.1	3.7	5.4	3.9	5.6	3.9	5.8	3.9	6.1	3.9	6.4	3.8
	20.0	4.6	3.5	5.1	3.7	5.4	3.9	5.6	3.9	5.8	3.9	6.1	3.9	6.4	3.8
	21.0	4.6	3.5	5.1	3.7	5.4	3.9	5.6	3.9	5.8	3.9	6.1	3.9	6.4	3.8
	23.0	4.6	3.5	5.1	3.7	5.4	3.9	5.6	3.9	5.8	3.9	6.1	3.9	6.4	3.8
	25.0	4.6	3.5	5.1	3.7	5.4	3.9	5.6	3.9	5.8	3.9	6.1	3.9	6.4	3.8
	27.0	4.6	3.5	5.1	3.7	5.4	3.9	5.6	3.9	5.8	3.9	6.1	3.9	6.4	3.8
	29.0	4.6	3.5	5.1	3.7	5.4	3.9	5.6	3.9	5.8	3.9	6.1	3.9	6.4	3.8
	31.0	4.6	3.5	5.1	3.7	5.4	3.9	5.6	3.9	5.8	3.9	6.1	3.9	6.4	3.8
	33.0	4.6	3.5	5.1	3.7	5.4	3.9	5.6	3.9	5.8	3.9	6.1	3.9	6.4	3.8
	35.0	4.6	3.5	5.1	3.7	5.4	3.9	5.6	3.9	5.8	3.9	6.1	3.9	6.4	3.8
37.0	4.5	3.3	4.9	3.6	5.3	3.8	5.4	3.8	5.6	3.8	5.9	3.7	6.2	3.7	
39.0	4.3	3.3	4.8	3.5	5.1	3.7	5.3	3.7	5.4	3.7	5.7	3.6	6.0	3.6	



7. Fan characteristics

MMD-AP0074SPH-E
MMD-AP0094SPH-E

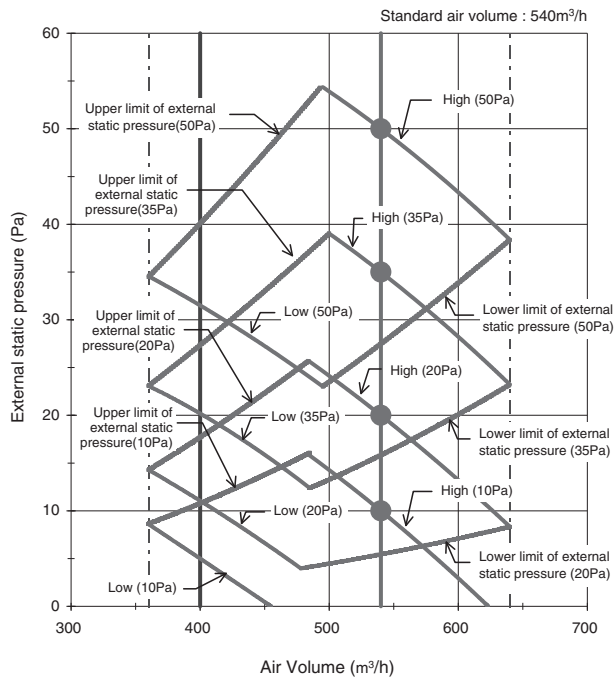

MMD-AP0124SPH-E

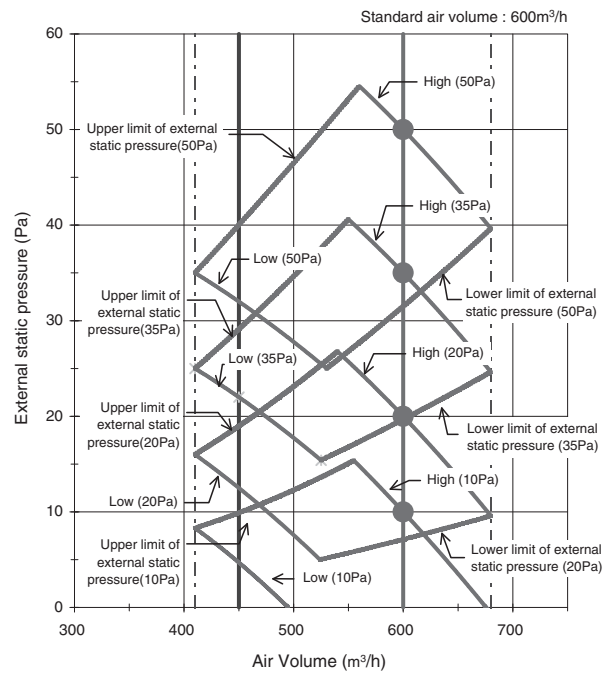

MMD-AP0154SPH-E

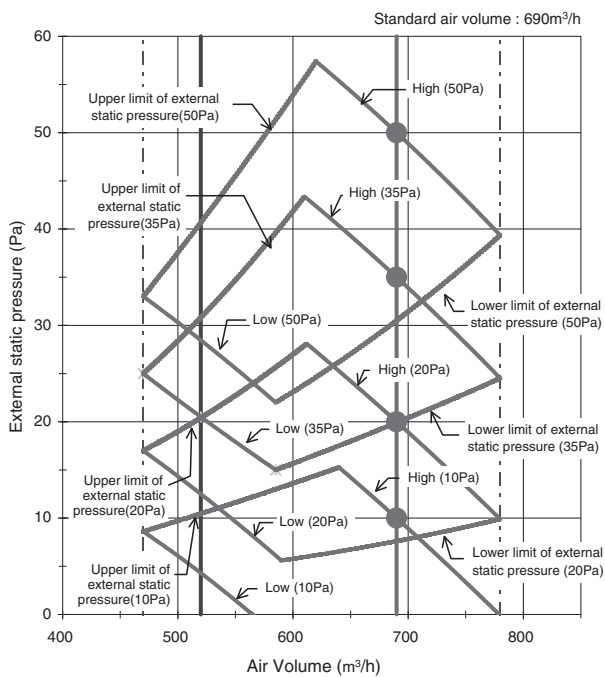

MMD-AP0184SPH-E

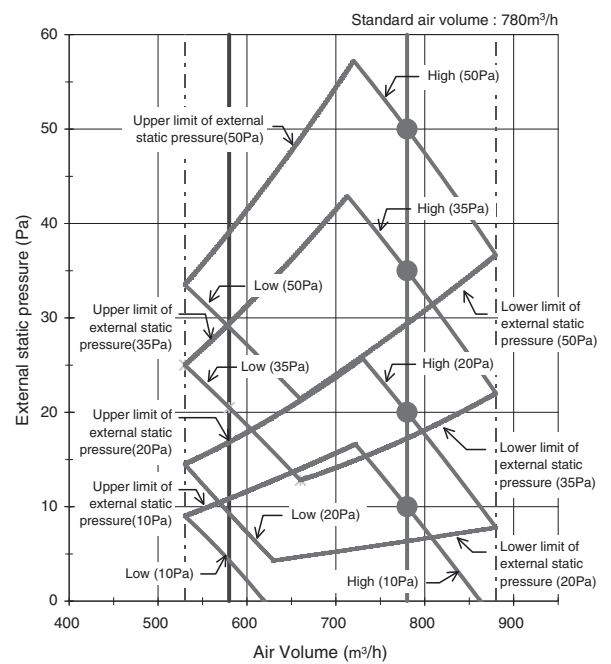



(Filter attached)

MMD-AP0074SPH-E
MMD-AP0094SPH-E

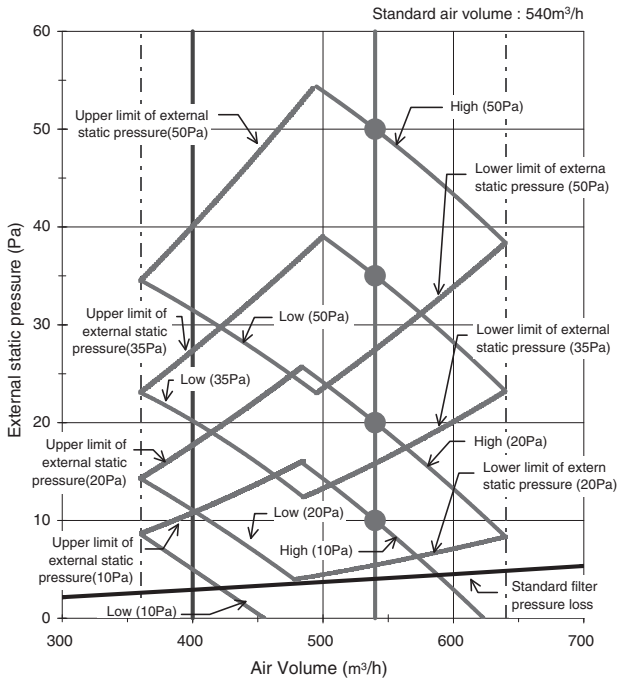

MMD-AP0124SPH-E

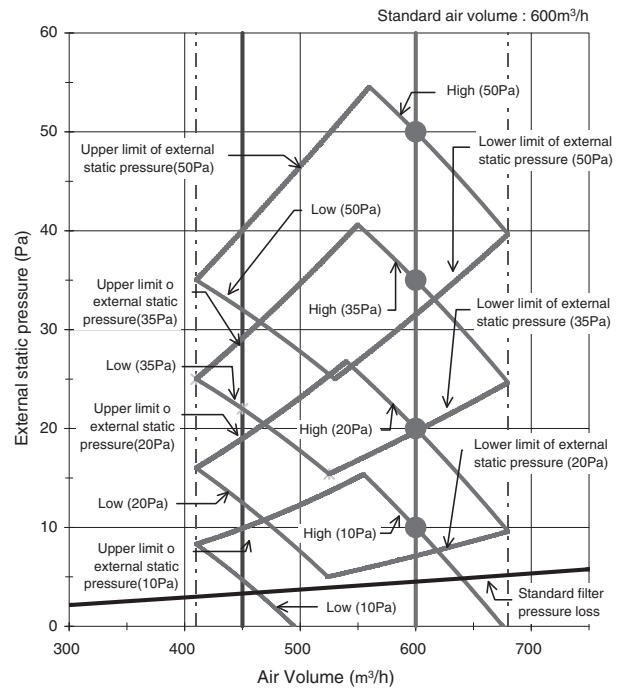

MMD-AP0154SPH-E

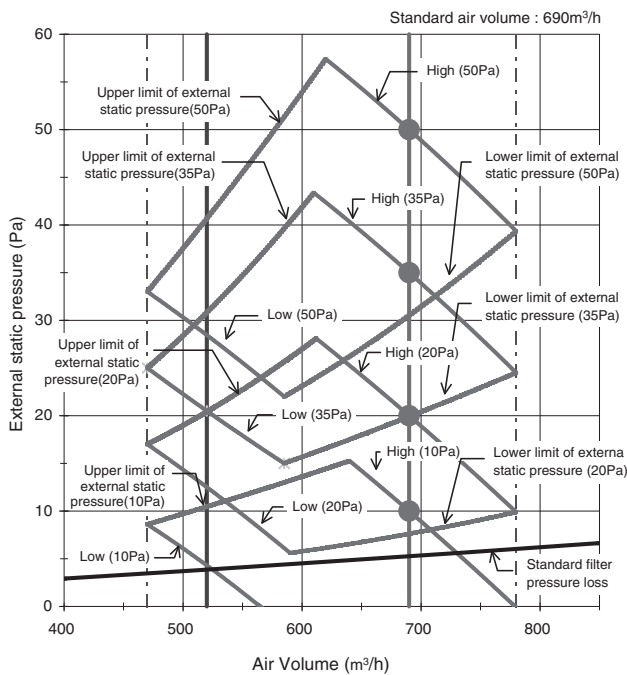

MMD-AP0184SPH-E

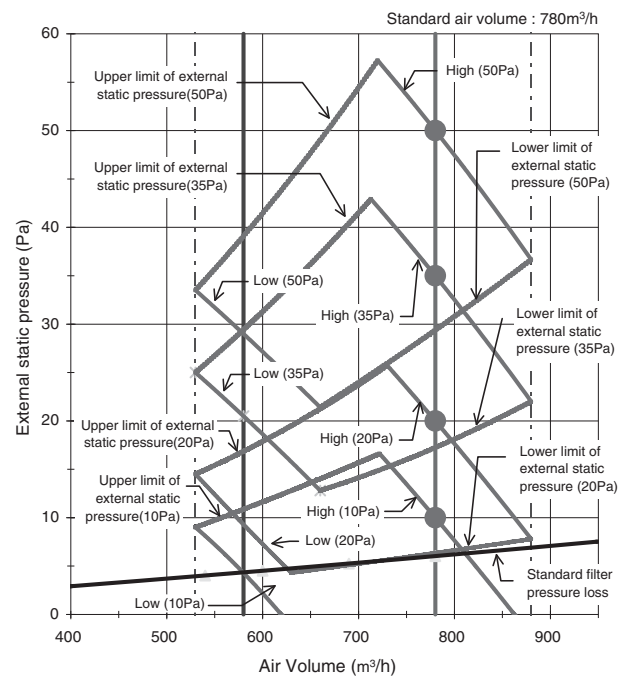



8. Sound Characteristics (NC Curve)

MMD-AP0074SPH-E
MMD-AP0094SPH-E

Measuring location

Rear air intake

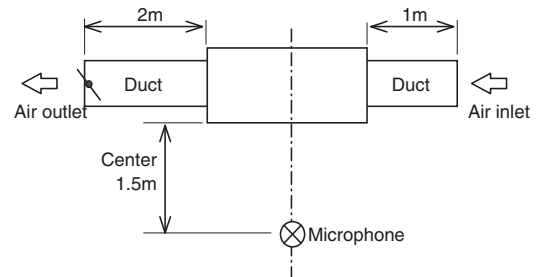

External static pressure 10Pa

Fan tap	H	M	L
Sound pressure level (dB(A))	28	26	24

External static pressure 20Pa

Fan tap	H	M	L
Sound pressure level (dB(A))	29	27	25

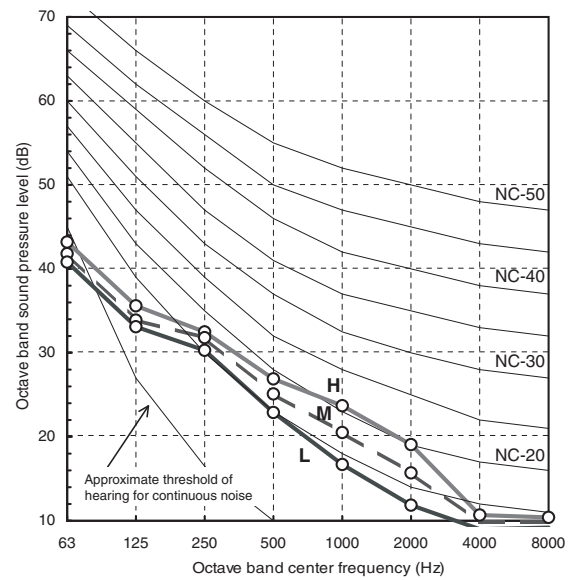
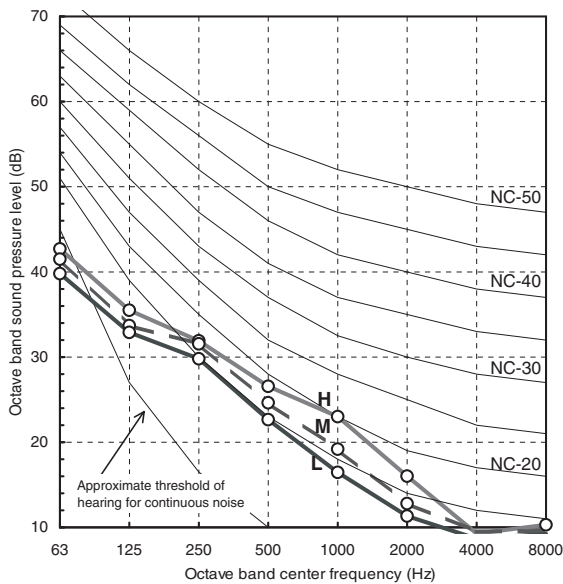

External static pressure 35Pa

Fan tap	H	M	L
Sound pressure level (dB(A))	30	28	26

External static pressure 50Pa

Fan tap	H	M	L
Sound pressure level (dB(A))	32	29	27

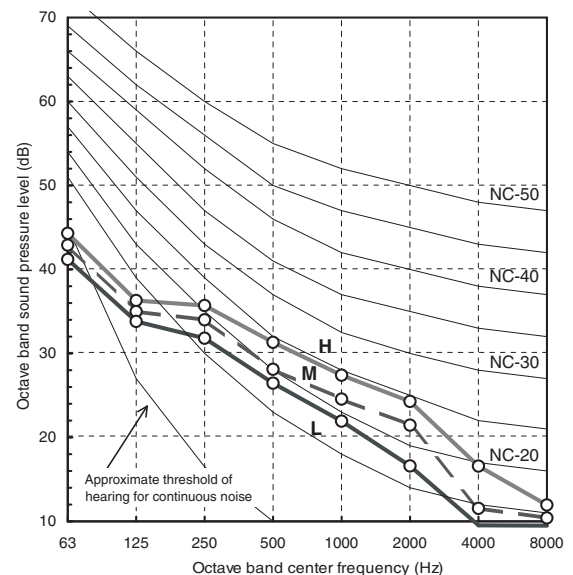
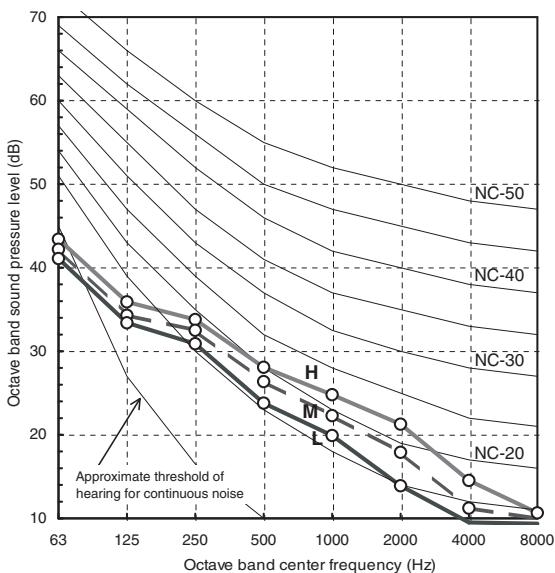



MMD-AP0124SPH-E

Measuring location

Rear air intake

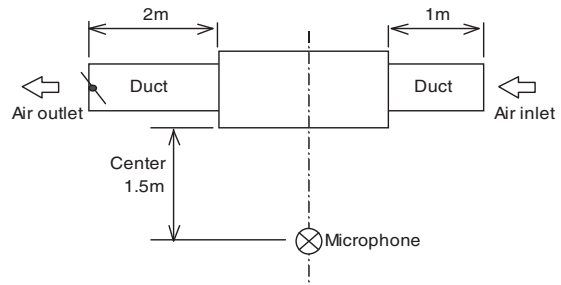

External static pressure 10Pa

Fan tap	H	M	L
Sound pressure level (dB(A))	29	27	25

External static pressure 20Pa

Fan tap	H	M	L
Sound pressure level (dB(A))	30	28	26

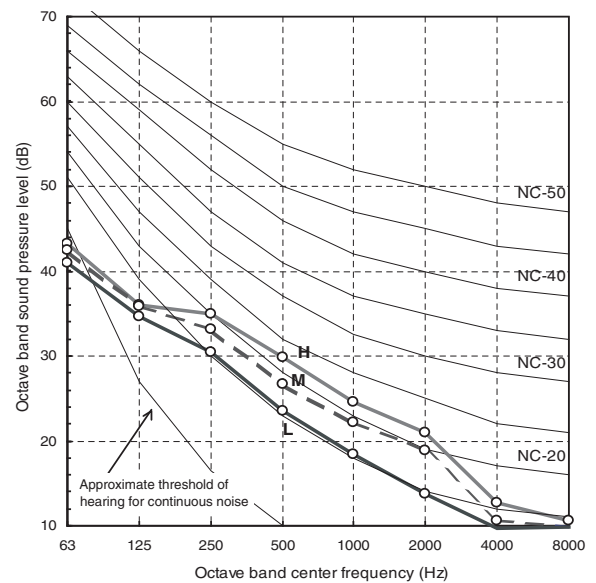
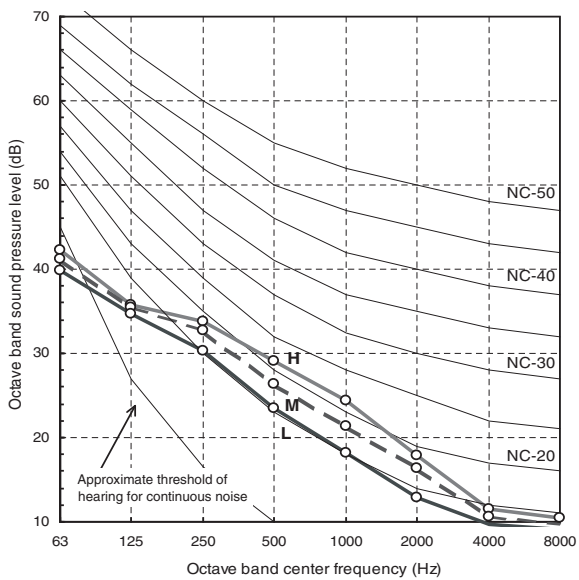

External static pressure 35Pa

Fan tap	H	M	L
Sound pressure level (dB(A))	31	29	27

External static pressure 50Pa

Fan tap	H	M	L
Sound pressure level (dB(A))	32	30	28

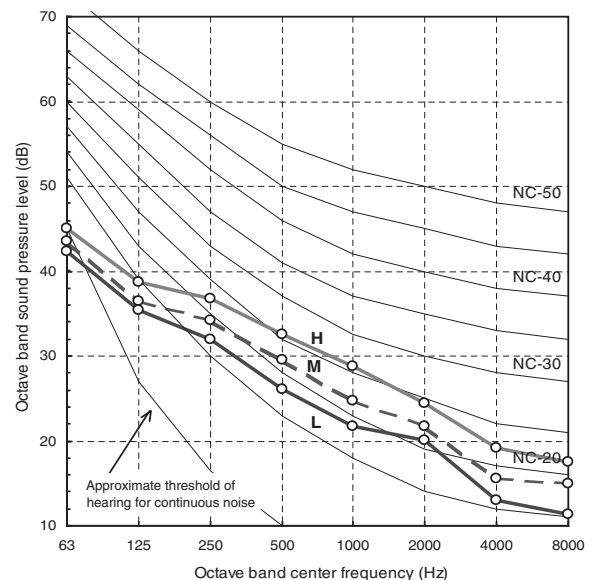
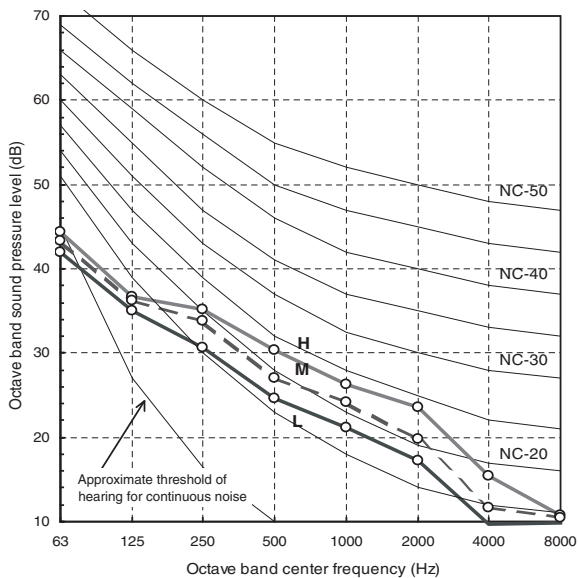



MMD-AP0154SPH-E

Measuring location

Rear air intake

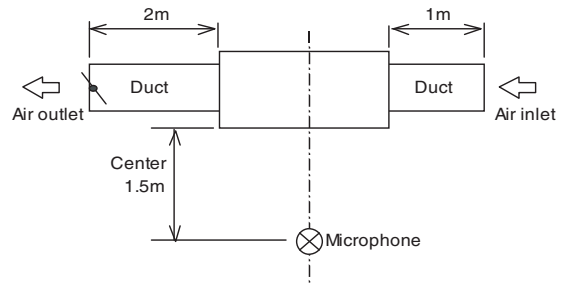

External static pressure 10Pa

Fan tap	H	M	L
Sound pressure level (dB(A))	32	30	28

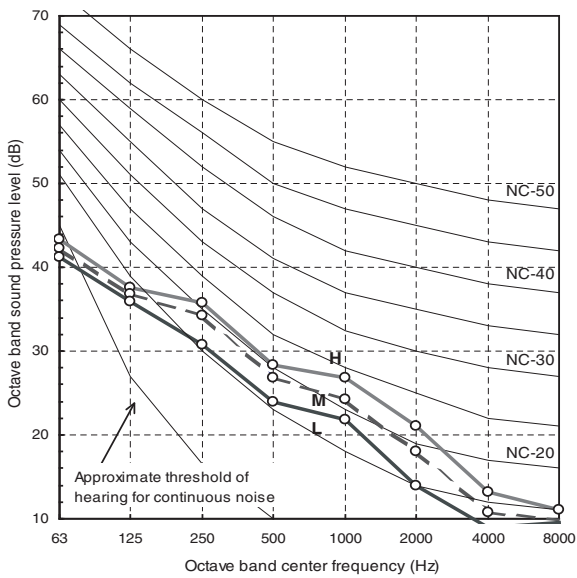

External static pressure 20Pa

Fan tap	H	M	L
Sound pressure level (dB(A))	33	31	29

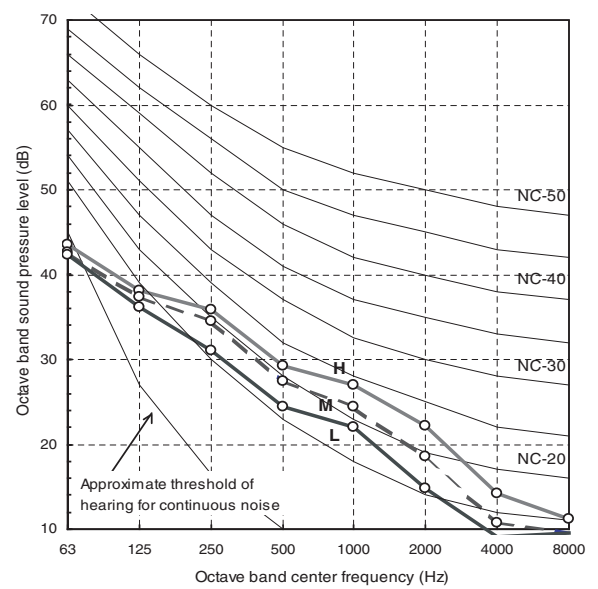

External static pressure 35Pa

Fan tap	H	M	L
Sound pressure level (dB(A))	34	32	30

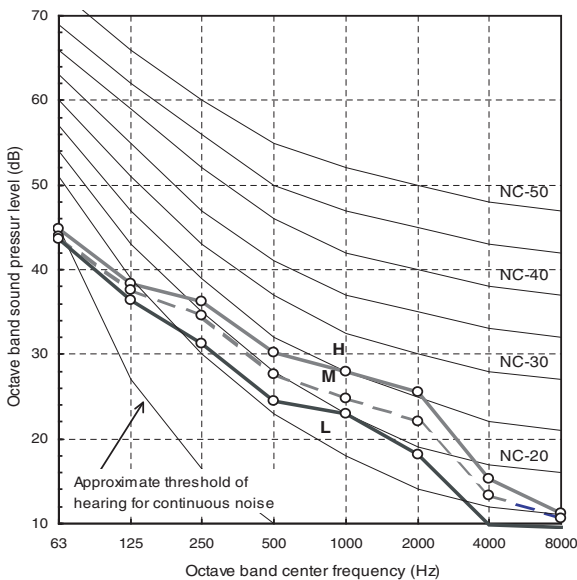

External static pressure 50Pa

Fan tap	H	M	L
Sound pressure level (dB(A))	35	33	31

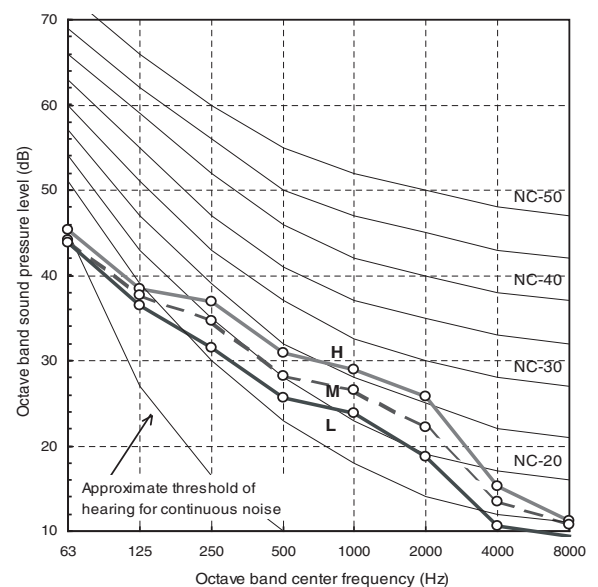



MMD-AP0184SPH-E

Measuring location

Rear air intake

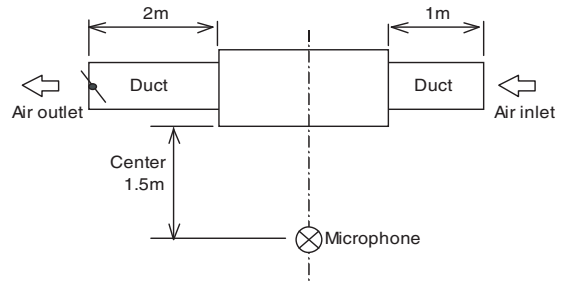

External static pressure 10Pa

Fan tap	H	M	L
Sound pressure level (dB(A))	33	31	29

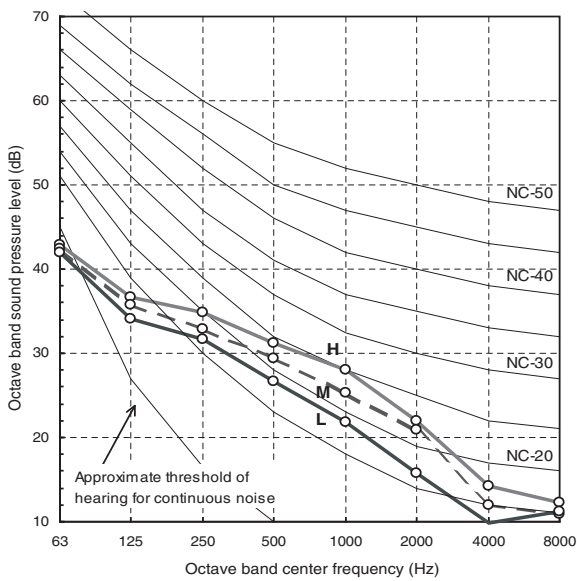

External static pressure 20Pa

Fan tap	H	M	L
Sound pressure level (dB(A))	34	32	30

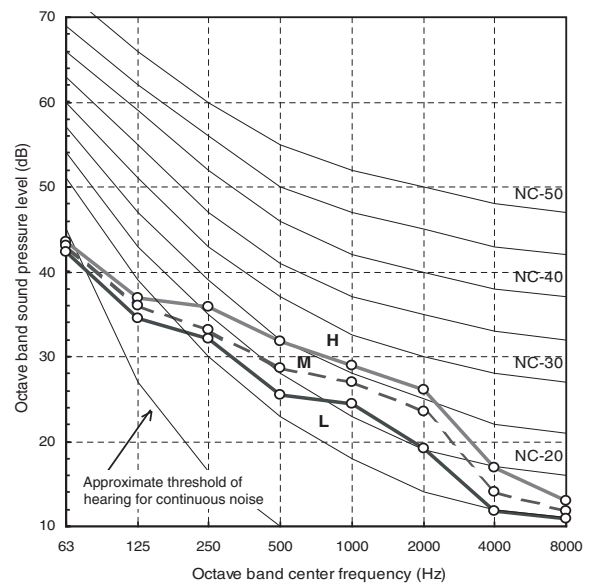

External static pressure 35Pa

Fan tap	H	M	L
Sound pressure level (dB(A))	35	33	31

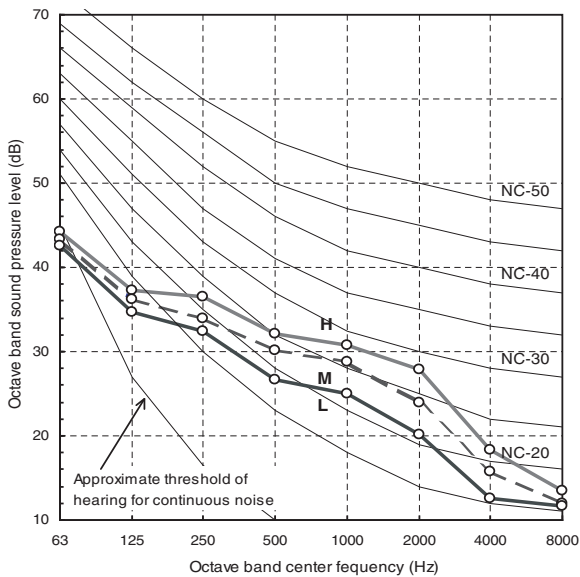

External static pressure 50Pa

Fan tap	H	M	L
Sound pressure level (dB(A))	36	34	32

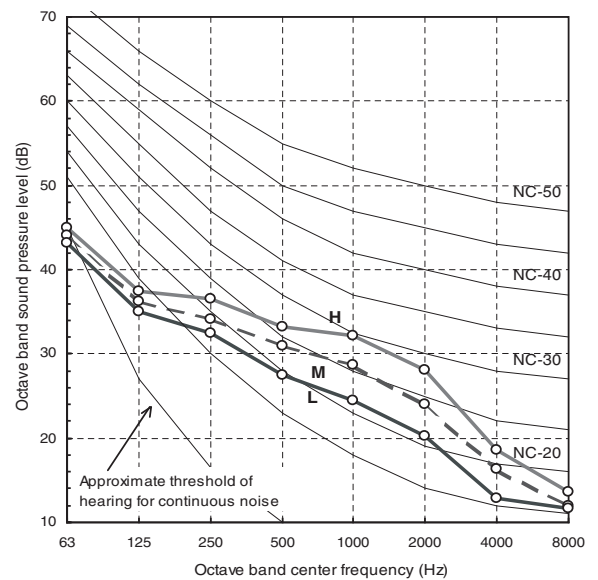



MMD-AP0074SPH-E
MMD-AP0094SPH-E

Measuring location

Under air intake

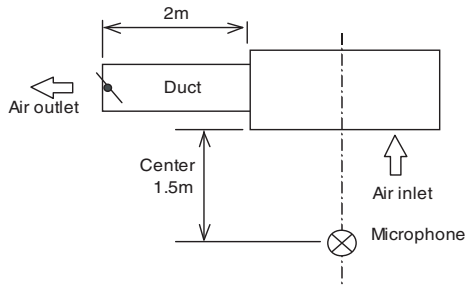

External static pressure 10Pa

Fan tap	H	M	L
Sound pressure level (dB(A))	36	33	30

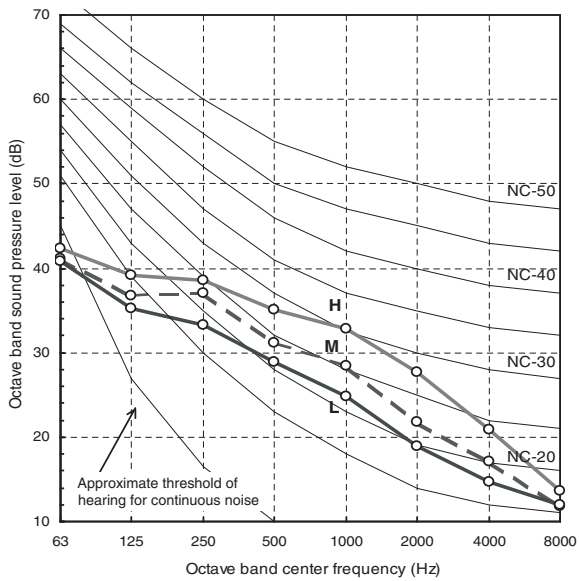

External static pressure 20Pa

Fan tap	H	M	L
Sound pressure level (dB(A))	37	34	31

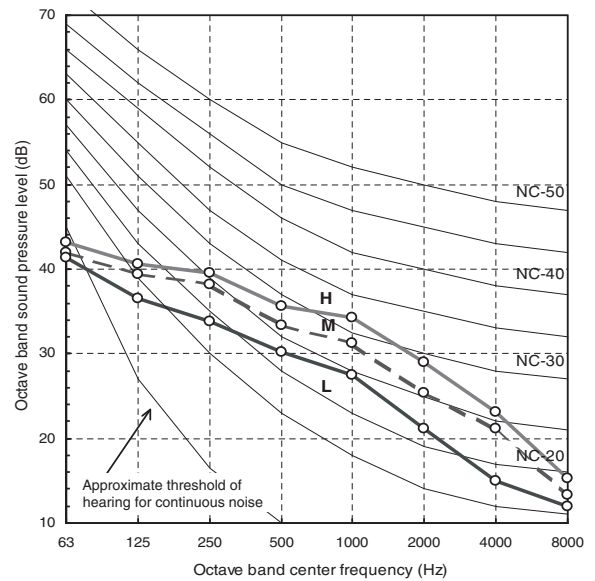

External static pressure 35Pa

Fan tap	H	M	L
Sound pressure level (dB(A))	39	36	33

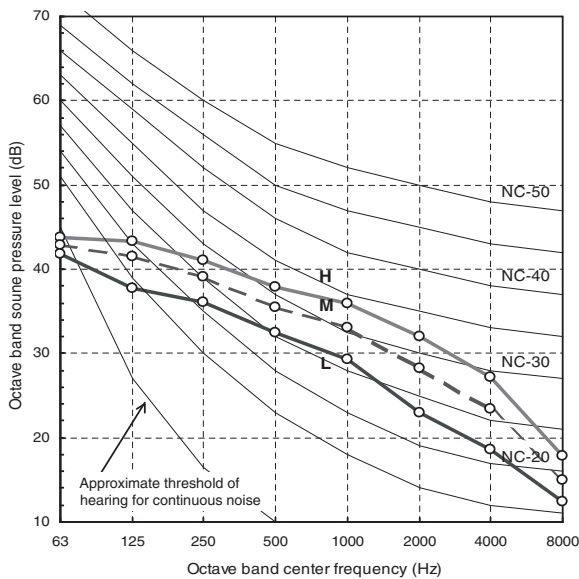

External static pressure 50Pa

Fan tap	H	M	L
Sound pressure level (dB(A))	41	38	35

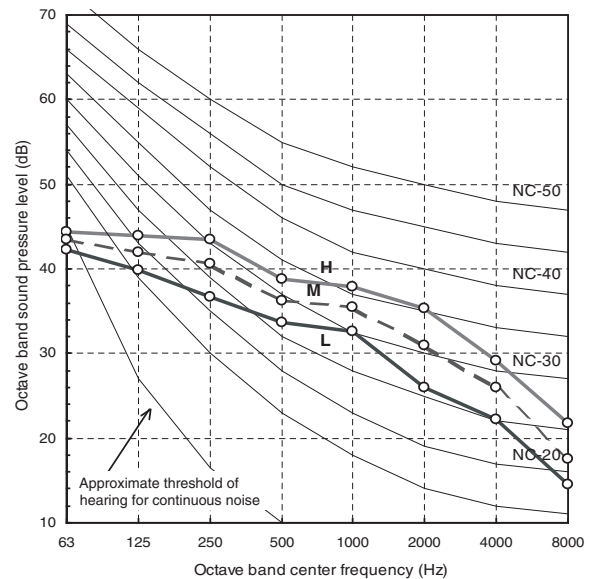



MMD-AP0124SPH-E

Measuring location

Under air intake

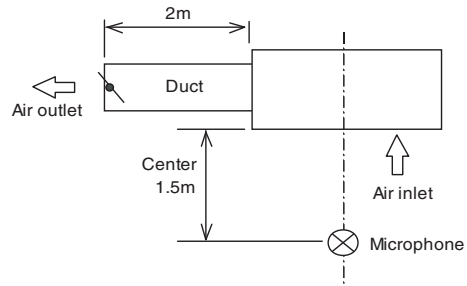

External static pressure 10Pa

Fan tap	H	M	L
Sound pressure level (dB(A))	38	35	32

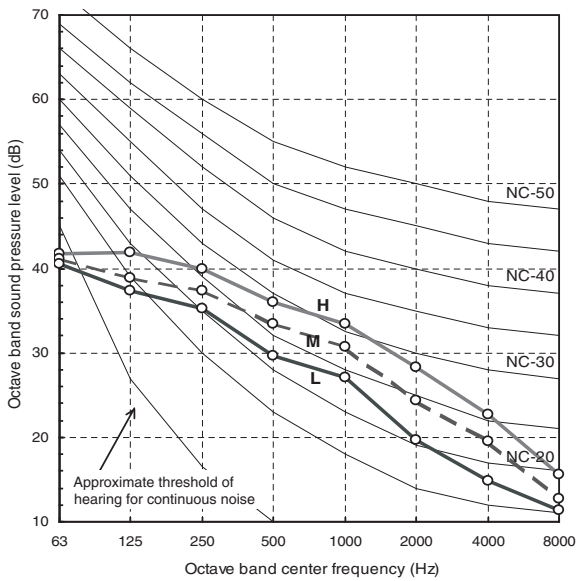

External static pressure 20Pa

Fan tap	H	M	L
Sound pressure level (dB(A))	39	36	33

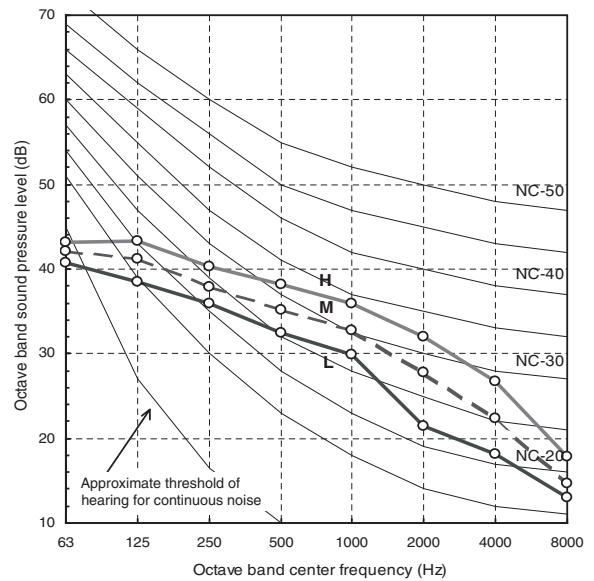

External static pressure 35Pa

Fan tap	H	M	L
Sound pressure level (dB(A))	41	38	35

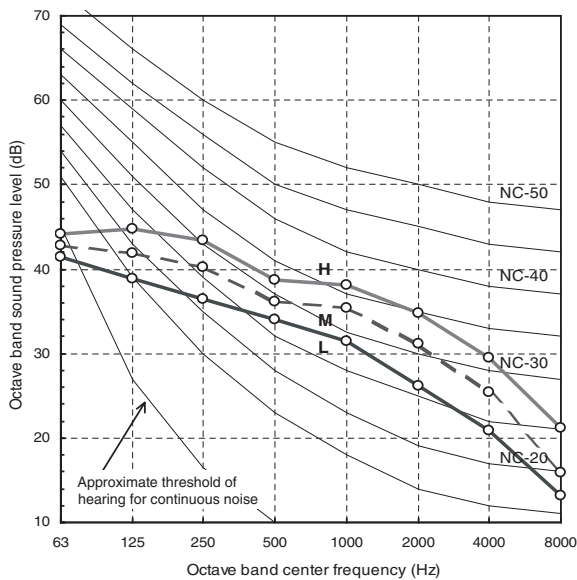

External static pressure 50Pa

Fan tap	H	M	L
Sound pressure level (dB(A))	43	40	37

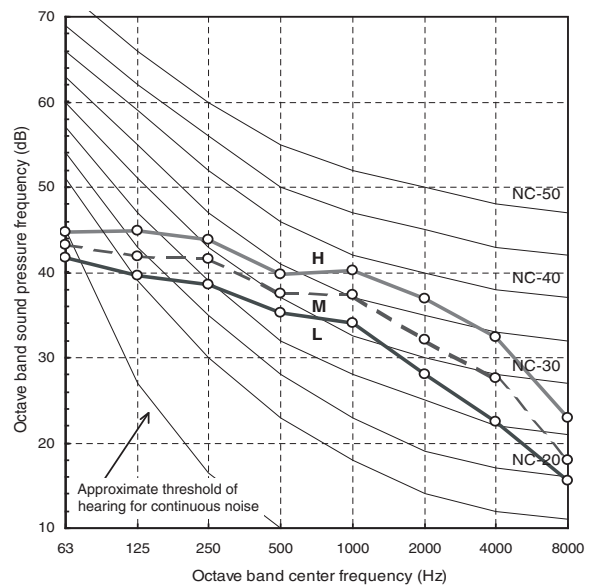



MMD-AP0154SPH-E

Measuring location

Under air intake

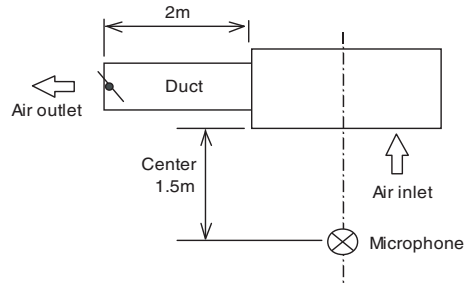

External static pressure 10Pa

Fan tap	H	M	L
Sound pressure level (dB(A))	39	36	33

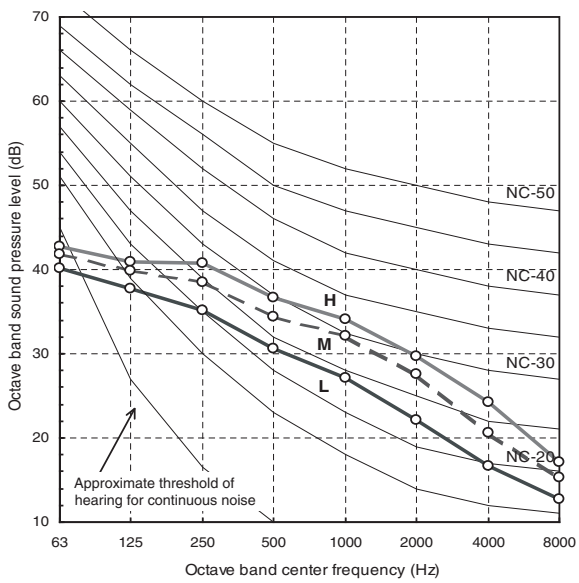

External static pressure 20Pa

Fan tap	H	M	L
Sound pressure level (dB(A))	40	37	34

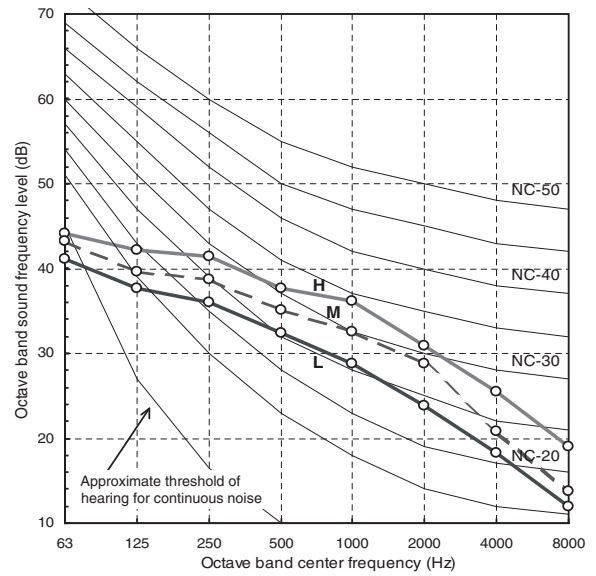

External static pressure 35Pa

Fan tap	H	M	L
Sound pressure level (dB(A))	41	38	35

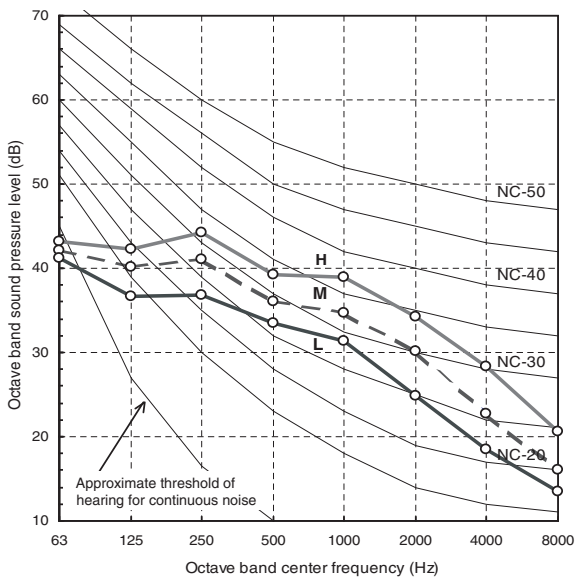

External static pressure 50Pa

Fan tap	H	M	L
Sound pressure level (dB(A))	43	40	37

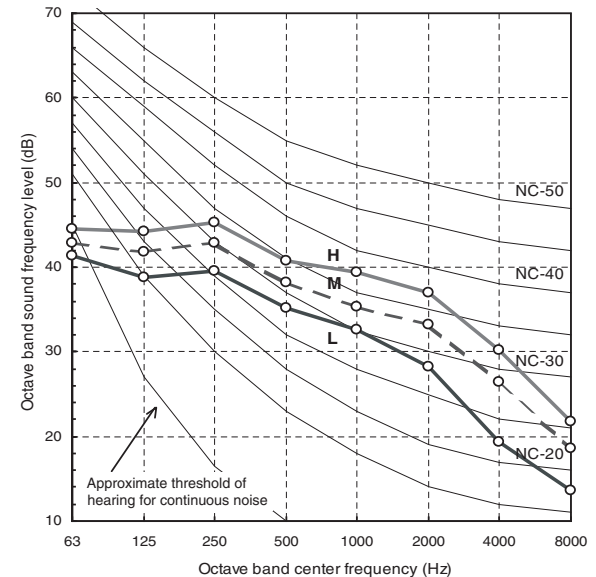



MMD-AP0184SPH-E

Measuring location

Under air intake

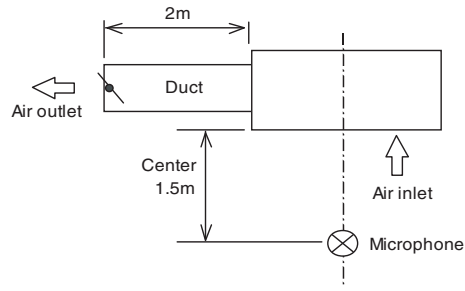

External static pressure 10Pa

Fan tap	H	M	L
Sound pressure level (dB(A))	40	38	36

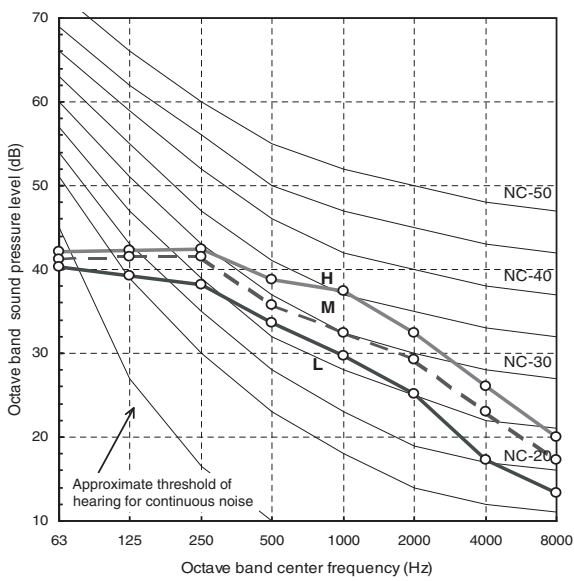

External static pressure 20Pa

Fan tap	H	M	L
Sound pressure level (dB(A))	42	40	37

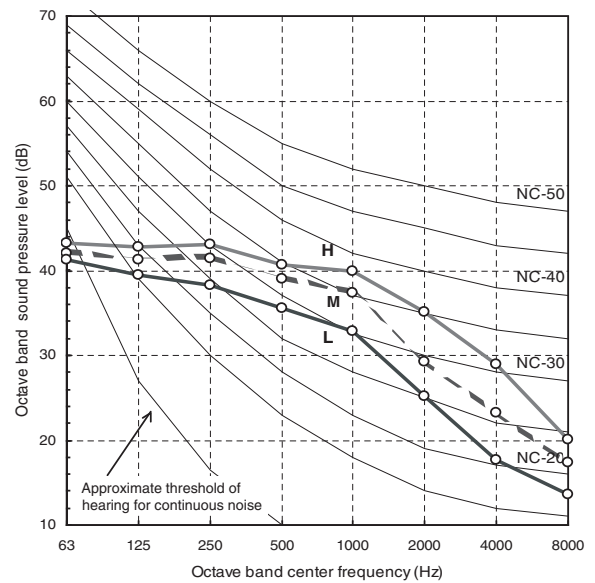

External static pressure 35Pa

Fan tap	H	M	L
Sound pressure level (dB(A))	43	41	38

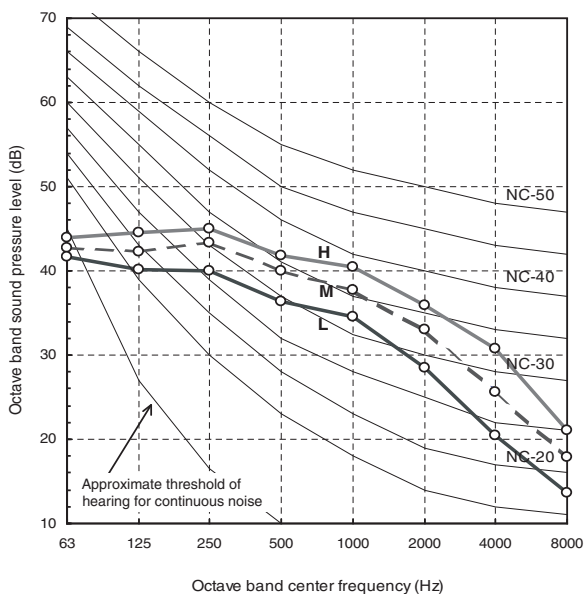

External static pressure 50Pa

Fan tap	H	M	L
Sound pressure level (dB(A))	44	42	39

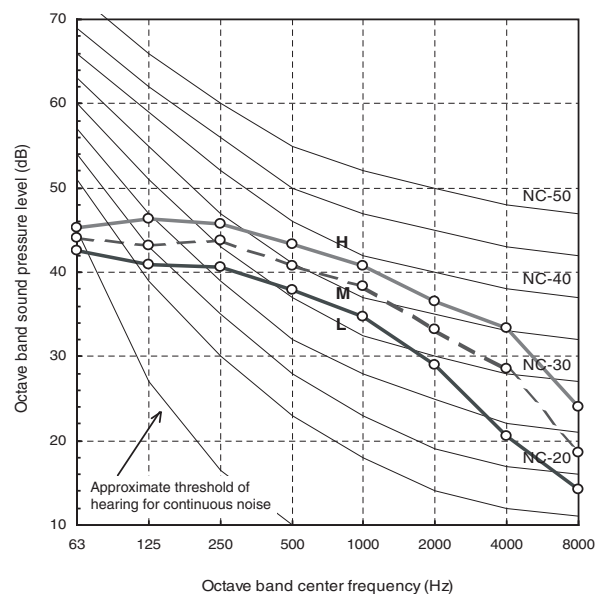

9. Fresh air intake (Design guide)

■ Slim Duct Type

MMD-AP0074SPH-E, AP0094SPH-E, AP0124SPH-E

Caution

The fresh air shall be conditioned by heat reclaim ventilator or similar.
Ensure the fresh air volume is determined so that mixed suction air and fresh air maintain the operating temperature.

*1. Recommended conditioned air temperature is 12 °C to 30 °C.

However, make a fresh air volume within 20% of standard.

Model name	MMD-	AP0074SPH-E	AP0094SPH-E	AP0124SPH-E
Standard air flow	(m ³ /h)	540	540	600

Install a air filter within the fresh air duct.

(Fresh air does not pass through the filter of Indoor unit.)

Insulate the fresh air duct.

Electrically connect the fan of the Heat exchanger unit and the Indoor unit to a single isolator.

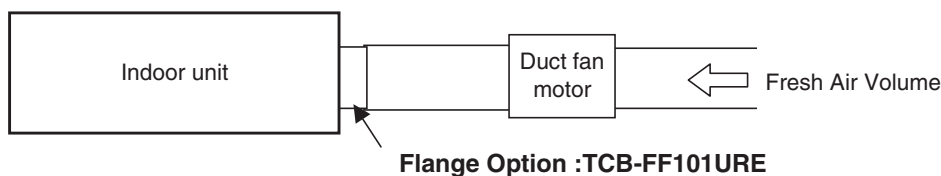
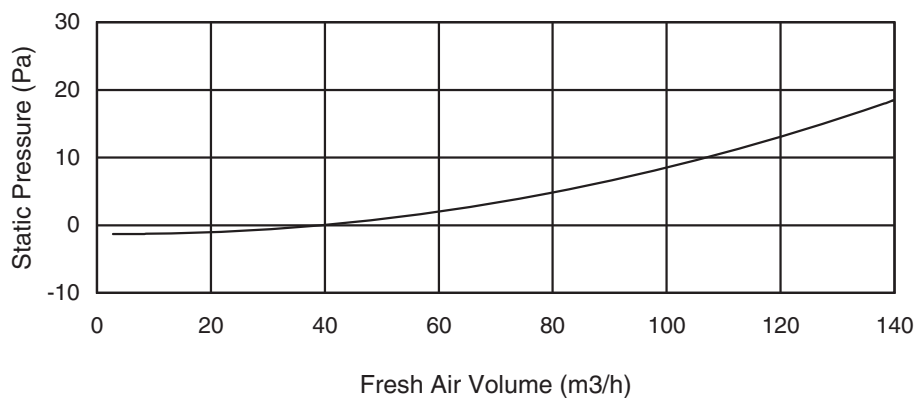

Inter - lock circuit

Connect the driving relay of the duct fan (DC 12V) between 1 and 6 on the indoor P.C. board.

(Rated current of the relay for duct fan should be up to 75mA.)

After installation, carry out a trial operation to check that the duct fan of the indoor unit start/stop simultaneously.

(Carry out the trial operation following the installation manual of the indoor unit.)



■ Slim Duct Type

MMD-AP0154SPH-E, AP0184SPH-E

Caution

The fresh air shall be conditioned by heat reclaim ventilator or similar.
 Ensure the fresh air volume is determined so that mixed suction air and fresh air maintain the operating temperature.

*1. Recommended conditioned air temperature is 12 °C to 30 °C.
 However, Make a fresh air volume within 20% of standard.

Model name	MMD-	AP0154SPH-E	AP0184SPH-E
Standard air flow (m³/h)		690	780

Install a air filter within the fresh air duct.

(Fresh air does not pass through the filter of Indoor unit.)

Insulate the fresh air duct.

Electrically connect the fan of the Heat exchanger unit and the Indoor unit to a single isolator.

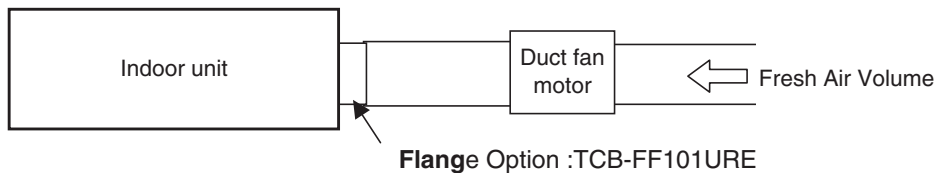
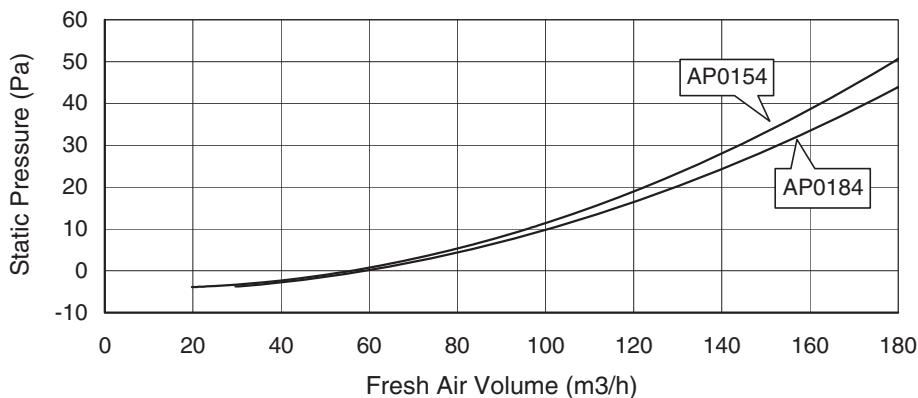

Inter - lock circuit

Connect the driving relay of the duct fan (DC 12V) between 1 and 6 on the indoor P.C. board.

(Rated current of the relay for duct fan should be up to 75mA.)

After installation, carry out a trial operation to check that the duct fan of the indoor unit start/stop simultaneously.

(Carry out the trial operation following the installation manual of the indoor unit.)



10. Accessories

Parts name	Model name	Applied model	Note	Remarks
Auxiliary fresh air flange	TCB-FF101URE2	MMD-AP***4SP+E	For fresh air intake by using the knockout hole of indoor unit. (dia.=100 mm)	

