

Limitation of scope of ETA-11/0429 (Hilti Firestop Coating CFS-CT, Hilti Firestop Double Board Seal) regarding the floor and wall application CFS-W P Firestop premium wrap

Dear Customer,

unfortunately, we need to inform you that the scope of the ETA- 11/0429 is limited as follows

- a. plastic pipes
- b. for EI 90 U/U and EI 120 U/U
- c. the construction Group 4 and 6 – outer diameter larger than 110 mm

this application can no longer be used described on ETA

- page 87 and 88, 91 and 92, 95 till 98 of 208 (point 2.2.14.6.1 / 2.2.14.6.2 / 2.2.14.6.5 / 2.2.14.6.6 / 2.2.14.6.9 / 2.2.14.6.10 / 2.2.14.6.11 / 2.2.14.6.12) and
- page 178 and 179, 181 till 182, 185 till 187 of 208 (point 2.6.10.5.1 / 2.6.10.5.2 / 2.6.10.5.4 / 2.6.10.5.5 / 2.6.10.5.8 / 2.6.10.5.9 / 2.6.10.5.10)



Gregory Dillen
Head of Marketing
Business Unit Fire Protection
Hilti Corporation



Martin Althof
Head of Quality
Business Unit Fire Protection
Hilti Corporation

Schaan, 2022-01-05

European Technical Assessment

ETA 11/0429

of 22/09/2021

General Part

Technical Assessment Body issuing the European Technical Assessment:	RISE Research Institutes of Sweden AB
Trade name of the construction product	Hilti Firestop Coating CFS-CT
Product family to which the construction product belongs	Fire stopping and fire sealing product- Penetration seal "Hilti Firestop Double Board Seal" for fire resistant walls and floors in buildings
Manufacturer	Hilti AG, Feldkircherstrasse 100, 9494 Schaan, Liechtenstein www.hilti.com
Manufacturing plant(s)	Hilti production plant 4a Hilti production plant 17
This European Technical Assessment contains	208 pages including 4 Annexes which form an integral part of this assessment.
This European Technical Assessment is issued in accordance with regulation (EU) No 305/2011, on the basis of	EAD 350454-00-1104, September 2017 - Fire stopping and fire sealing products – penetration seals
Additional text	This ETA replaces ETA 11/0429 issued on 17/09/2018

Translations of this European Technical Assessment in other languages shall fully correspond to the original issued document and should be identified as such.

Communication of this European Technical Assessment, including transmission by electronic means, shall be in full. However, partial reproduction may be made with the written consent of the issuing Technical Assessment Body. Any partial reproduction has to be identified as such.

Content

1	Technical description of the product	10
1.1	Definition of the construction product.....	10
2	Specification of the intended use(s) in accordance with the applicable European Assessment Document (hereinafter EAD).....	10
2.1	Intended use	10
2.2	Use category	12
2.3	Working life.....	12
3	Performance of the product and references to the methods used for its assessment	12
3.1	Essential characteristics and their performance.....	12
3.1.1	Mechanical resistance and stability (BWR 1).....	13
3.1.2	Safety in case of fire (BWR 2).....	13
3.1.2.1	Reaction to fire.....	13
3.1.2.2	Resistance to fire.....	13
3.1.3	Hygiene, health and environment (BWR 3)	13
3.1.3.1	Air permeability	13
3.1.3.2	Water permeability.....	13
3.1.3.3	Release of dangerous substances.....	13
3.1.4	Safety in use (BWR 4)	14
3.1.4.1	Mechanical resistance and stability.....	14
3.1.4.2	Resistance to impact and movement.....	14
3.1.4.3	Adhesion.....	14
3.1.4.4	Durability – use category.....	14
3.1.4.5	Durability - Flexibility Hilti Firestop Coating CFS-CT	14
3.1.4.6	Durability - Compatibility of Hilti Firestop Coating CFS-CT with metals/plastics	14
3.1.5	Protection against noise (BWR 5).....	15
3.1.5.1	Airborne sound insulation.....	15
3.1.6	Energy economy and heat retention (BWR 6).....	15
3.1.6.1	Thermal properties.....	15
3.1.6.2	Water vapor permeability	15
3.1.7	Sustainable use of natural resources (BWR 7)	15
4	Assessment and verification of constancy of performance (hereinafter AVCP) system applied, with reference to its legal base.....	16
5	Technical details necessary for the implementation of the AVCP system, as provided for in the applicable EAD	16
1	ANNEX 1 Description of Product(s) and Product Literature.....	17
1.1	Products	17
1.1.1	Hilti Firestop Coating CFS-CT	17
1.1.2	Hilti Firestop Board CFS-CT B 1S.....	17
1.1.3	Hilti Firestop Board CFS-CT B 2S.....	17
1.2	Ancillary Products	18
1.2.1	Hilti Firestop Acrylic Sealant CFS-S ACR	18
1.2.2	Hilti Firestop Collar CFS-C	18
1.2.3	Hilti Firestop Collar CFS-C P.....	18
1.2.4	Hilti Firestop Collar Endless CFS-C EL.....	18

1.2.5	Hilti Firestop Bandage CFS-B	18
1.2.6	Hilti Firestop Wrap CFS-W	18
1.2.7	Hilti Firestop Wrap CFS-W P	18
1.2.8	Hilti Firestop Sleeve CFS-SL M and Hilti Firestop Sleeve CFS-SL GA	18
1.2.9	Fixing for Hilti Firestop Collars CFS-C and CFS-C P	18
1.2.10	Fixing for Hilti Firestop Collar Endless CFS-C EL	18
1.2.11	Mineral wool products for additional protection	19
1.2.12	Pipe insulation products	19
1.3	Technical product literature	20
1.4	Installation	21
1.4.1	Installation of the penetration seal "Hilti Firestop Double Board Seal", when using a MW board according to Table 1 and Hilti Firestop Coating CFS-CT	21
1.4.2	Installation of the penetration seal "Hilti Firestop Double Board Seal", when using the pre-coated boards Hilti Firestop Board CFS-CT B 1S or CFS-CT B 2S	22
1.4.3	Application temperature	23
1.4.4	Re-penetration / removal of services	23
1.5	Indications to the manufacturer	23
1.5.1	Packaging, transport and storage	23
1.5.2	Use, maintenance, repair	23
2	ANNEX 2 RESISTANCE TO FIRE CLASSIFICATION OF PENETRATION SEALS HILTI FIRESTOP DOUBLE BOARD SEAL	24
2.1	General Information Hilti Firestop Double Board Seal	24
2.1.1	Intended use of penetrations and reference to relevant section	25
2.1.2	Additional protection for cable/small conduit penetrations	33
2.1.3	Additional components for composite and plastic pipe penetrations	33
2.1.4	Additional components for metal pipe penetrations	34
2.1.5	Additional components for cable penetrations	34
2.1.6	Non-regulated PP-pipes	35
2.2	Flexible walls according to 2.1 a) and rigid walls according to 2.1 b), minimum thickness 100 mm	36
2.2.1	Blank seal (no services) *	37
2.2.2	Cables	38
2.2.3	Cables with Hilti Firestop Sleeve CFS-SL M and Hilti Firestop Sleeve CFS-SL GA 40	40
2.2.4	Small conduits and tubes	40
2.2.4.1	3 plastic conduits in 1 Hilti Firestop Collar CFS-C P – U/U	41
2.2.5	Metal pipes	42
2.2.5.1	Metal pipes with mineral wool insulation according to Table 3	42
2.2.5.1.1	Steel pipes with mineral wool insulation according to Table 3	43
2.2.5.1.2	Copper pipes with mineral wool insulation according to Table 3	46
2.2.5.2	Metal pipes with foamed elastomeric insulation according Table 4 and Hilti Firestop Bandage CFS-B	48
2.2.5.2.1	Steel pipes with foamed elastomeric insulation according Table 4 and Hilti Firestop Bandage CFS-B 49	49
2.2.5.2.2	Stainless steel pipes with foamed elastomeric insulation according Table 4 and Hilti Firestop Bandage CFS-B	50
2.2.5.2.3	Copper pipes with foamed elastomeric insulation according Table 4 and Hilti Firestop Bandage CFS-B	50

2.2.6	Plastic pipes with Hilti Firestop Collar CFS-C P.....	52
2.2.6.1	PVC-U pipes (C) according to EN ISO 1452-2, EN ISO 15493, DIN 8061/8062 – U/U	52
2.2.6.2	PE pipes (C) according to EN 1519 - U/U.....	53
2.2.6.3	PE pipes (C) according to EN ISO 15494, DIN 8074/8075 – U/U.....	53
2.2.6.4	PE-S2 pipes “Geberit Silent-db20”.....	54
2.2.6.4.1	PE-S2 pipes “Geberit Silent-db20”– U/U.....	54
2.2.6.4.2	PE-S2 pipes “Geberit Silent-db20”– C/U.....	54
2.2.6.5	PE-HD 100 RC pipes “Wavin TS”– U/U.....	54
2.2.6.6	Non-regulated PP pipes with Hilti Firestop Collar CFS-C P.....	55
2.2.6.6.1	PP pipes according EN 1451-1 – U/U.....	55
2.2.6.6.2	PP pipes according EN 1451-1 – C/U.....	55
2.2.6.6.3	PP pipes according EN 1451-1 – U/C.....	55
2.2.6.7	PP pipes according to EN ISO 15874 and/or DIN 8077/8078 with Hilti Firestop Collar CFS-C P.....	56
2.2.6.7.1	PP-H pipes “PROGEF standard pipe” – U/C.....	56
2.2.6.7.2	PP-H pipes “PROGEF standard pipe” – U/U.....	56
2.2.6.7.3	PP-R pipes according EN ISO 15874 – U/C.....	56
2.2.6.7.4	PP-H 100 pipes “Dekaprop Industry pipes” – U/U.....	56
2.2.6.8	ABS/PUR/PE-HD pipes “Coolfit”– U/C.....	57
2.2.6.9	Special pipes with Hilti Firestop Collar CFS-C P.....	58
2.2.7	Plastic pipes with foamed elastomeric insulation according to Table 4 and Hilti Firestop Collar CFS-C P.....	60
2.2.7.1	PE pipes (C) according to EN 1519 ¹⁸ (C) with continued insulation (D) – sustained – U/U.....	60
2.2.7.2	Special plastic Pipes (C) with continued insulation (D) – sustained – U/C.....	60
2.2.7.2.1	PE-X pipes according EN ISO 15875.....	60
2.2.7.2.2	PP pipes “Fusiotherm SDR 11” - U/C.....	61
2.2.7.2.3	PP pipes “Fusiotherm Faser SDR 7.4/S3.2” - U/C.....	61
2.2.7.2.4	PE-100RC pipes “ Wavin TS” - U/C.....	61
2.2.7.2.5	PVC-C pipes “Friatherm starr”,.....	62
2.2.7.3	PE pipes (C) according to EN 1519 ¹⁸ (C) with continued insulation (D) – interrupted – U/U.....	62
2.2.7.4	Pipes (C) with local insulation (D) – sustained – U/C.....	62
2.2.7.4.1	PE-X pipes according EN ISO 15875.....	62
2.2.7.4.2	PP pipes “Fusiotherm SDR 11”.....	63
2.2.7.4.3	PP pipes “Fusiotherm Faser SDR 7.4/S3.2”.....	63
2.2.7.4.4	PE-100RC pipes “Wavin TS”.....	63
2.2.7.4.5	PVC-C pipes “Friatherm starr”.....	64
2.2.8	Plastic pipes with Hilti Firestop Collar CFS-C.....	64
2.2.8.1	PVC-U pipes (C) according to EN ISO 1452-2, EN ISO 15493, DIN 8061/8062.....	64
2.2.8.2	PE pipes (C) according to EN ISO 15494, DIN 8074/8075.....	65
2.2.8.3	PE pipes (C) according to EN 1519 ¹⁸	65
2.2.9	Plastic pipes with Hilti Firestop Collar Endless CFS-C EL.....	66
2.2.9.1	Plastic pipes acc. EN 1519-1, EN 12666-1, EN 12201-2 and ABS-pipes acc. EN 1455- 1 and SAN+PVC-pipes acc. EN 1565-1.....	67

2.2.9.2	ABS- pipes acc. EN 1455, EN 15493 and SAN+PVC-pipes acc. EN 1565-1, penetrating Hilti Firestop Boards CFS-CT B IS	67
2.2.9.3	PE pipes acc. EN15494, EN12201-2 and DIN 8074/75	68
2.2.9.4	PVC pipes acc. EN 1452-1, EN 1329-1, EN 1453-1, EN 1566-1, EN ISO 15493 and DIN 8061/62.....	68
2.2.9.5	PP pipes, non-regulated.....	69
2.2.9.6	PP pipes acc. EN1451-1 and DIN 8077/78.....	70
2.2.9.7	PE pipes, non-regulated (Geberit Silent dB20)	70
2.2.10	Plastic pipes with Hilti Firestop Wrap CFS-W	71
2.2.10.1	PVC-U pipes (C) according to EN ISO 1452-2, EN ISO 15493, DIN 8061/8062 – U/C	71
2.2.10.2	PE pipes (C) according to EN 151918 - U/C.....	71
2.2.10.3	PE pipes (C) according to EN ISO 15494, DIN 8074/8075 – U/C.....	72
2.2.10.4	PP pipes (C) “Wavin AS” or “Phonex AS” – C/U Manufacturer: Wavin Ltd. or KeKelit	72
2.2.10.5	PP pipes (C) “Raupiano plus” – C/U Manufacturer: Rehau	72
2.2.10.6	PE-S2 pipes (C) “Geberit Silent db20” Manufacturer: Geberit	73
2.2.11	Al-Composite pipes with foamed elastomeric insulation according to Table 4 and Hilti Firestop Collar CFS-C P	74
2.2.11.1	Pipes (C) with continued insulation (D) – sustained – U/C.....	74
2.2.12	Al-Composite pipes with foamed elastomeric insulation according Table 4 and Hilti Firestop Bandage CFS-B	76
2.2.12.1	Al-composite pipes (C) with continued insulation (D) – sustained – U/C.....	77
2.2.12.2	Al-composite pipes (C) with local insulation (D) – sustained – U/C.....	77
2.2.13	Al-composite pipes with mineral wool insulation according to Table 3	78
2.2.13.1	Pipes (C) with continued insulation (D) – sustained – U/C.....	78
2.2.13.2	Pipes (C) with local insulation (D) – sustained – U/C	79
2.2.14	Plastic pipes with Hilti Firestop Wrap CFS-W P.....	80
2.2.14.1	Plastic pipes, sealed with Hilti Firestop Wrap CFS-W P – seal design variations in wall.....	81
2.2.14.2	Foamed elastomeric insulation.....	84
2.2.14.3	Pipes, sealed with Hilti Firestop Wrap CFS-W P – construction groups.....	85
2.2.14.4	Pipe support construction	86
2.2.14.5	Separation of penetrations	86
2.2.14.6	Plastic pipes sealed with Hilti Firestop Wrap CFS-W P penetrating a double board seal CFS-CT in wall.....	87
2.2.14.6.1	PE - pipes according to EN 1519-1, EN 12666-1, EN 12201-2 for EI 90-U/U	87
2.2.14.6.2	PE – pipes according to EN 1519-1, EN 12666-1, EN 12201-2 for EI 120-U/U	88
2.2.14.6.3	PE – pipes (isolated) acc.to EN 1519-1, EN 12666-1, EN 12201-2 for EI 90-U/U.....	89
2.2.14.6.4	PE – pipes (isolated) acc. to EN 1519-1, EN 12666-1, EN 12201-2 for EI 120-U/U.....	90
2.2.14.6.5	PE-pipes, Geberit Silent dB20 EI 90-U/U	91
2.2.14.6.6	PE-pipes, Geberit Silent dB20 EI 120-U/U	92
2.2.14.6.7	PE – pipes acc. EN 15494 EI 90-U/C.....	93
2.2.14.6.8	PE – pipes acc. EN 15494 EI 120-U/C.....	94
2.2.14.6.9	PP – pipes, non-regulated EI 90-U/U.....	95
2.2.14.6.10	PP – pipes, non-regulated EI 120-U/U.....	96
2.2.14.6.11	PVC-pipes according to EN 1452-1 - EI 90-U/U	97

2.2.14.6.12	PVC-pipes according to EN 1452-1 - EI 120-U/U	98
2.2.14.6.13	Geberit PushFit PB	99
2.2.15	Aluminium composite pipes with elastomeric insulation, penetrating a CFS-CT double board seal, provided with Hilti firestop wrap CFS-W P and gap filler.....	100
2.2.15.1	Rehau Rautitan Stabil, penetrating CFS-CT, sealed with CFS-W P.....	100
2.2.15.2	Uponor MLC, penetrating CFS-CT, sealed with CFS-W P	101
2.2.15.3	Kekelit Kelox, penetrating CFS-CT, sealed with CFS-W P	102
2.2.15.4	Geberit Mepla, penetrating CFS-CT, sealed with CFS-W P	103
2.2.15.5	Viega Sanfix Fosta and Viega Raxofix, penetrating CFS-CT, sealed with CFS-W P	104
2.2.15.6	Geberit PushFit ML, penetrating CFS-CT, sealed with CFS-W P	106
2.2.16	Metal pipes with elastomeric insulation, penetrating a CFS-CT double board seal, provided with Hilti firestop wrap CFS-W P and gap filler	107
2.2.16.1	Isolated copper pipes, penetrating CFS-CT, sealed with CFS-W P	107
2.2.16.2	Isolated steel pipes, penetrating CFS-CT, sealed with CFS-W P	109
2.3	Flexible walls according to 2.1 a) and rigid walls according to 2.1 b), minimum thickness 135 mm	112
2.3.1	Metal pipes.....	112
2.3.1.1	Metal pipes with mineral wool insulation according to Table 3.....	112
2.3.1.1.1	Steel pipes with mineral wool insulation according to Table 3	112
2.3.1.1.2	Copper pipes with mineral wool insulation according to Table 3.....	113
2.3.2	Plastic pipes with Hilti Firestop Collar CFS-C.....	114
2.3.2.1	PVC-U pipes (C) according to EN ISO 1452-2, EN ISO 15493, DIN 8061/8062 – U/C	114
2.3.2.2	PE pipes (C) according to EN ISO 15494, DIN 8074/8075.....	114
2.4	Rigid walls according to 2.1 c), minimum thickness 150 mm	115
2.4.1	Cables.....	116
2.4.2	Small conduits and tubes	116
2.4.3	Metal pipes with mineral wool insulation according to Table 3.....	116
2.4.3.1	Steel pipes with mineral wool insulation according to Table 3	116
2.4.3.2	Copper pipes with mineral wool insulation according to Table 3.....	117
2.4.4	Plastic pipes with Hilti Firestop Collar CFS-C.....	117
2.5	Rigid walls according to 2.2 d), minimum thickness 150 mm	118
2.5.1	Cables.....	119
2.5.2	Small conduits and tubes	119
2.5.3	Metal pipes with foamed elastomeric insulation according Table 4 and Hilti Firestop Bandage CFS-B	120
2.5.3.1	Steel pipes with foamed elastomeric insulation according Table 4 and Hilti Firestop Bandage CFS-B.....	120
2.5.3.2	Stainless steel pipes with foamed elastomeric insulation according Table 4 and Hilti Firestop Bandage CFS-B.....	121
2.5.3.3	Copper pipes with foamed elastomeric insulation according Table 4 and Hilti Firestop Bandage CFS-B.....	122
2.6	Rigid floors according to 1.2 e), minimum thickness 150 mm	123
2.6.1	Blank seal (no services) *	125
2.6.2	Cables.....	126
2.6.3	Small conduits and tubes	127
2.6.3.1	3 plastic conduits in 1 Hilti Firestop Collar CFS-C P – U/C	128
2.6.4	Metal pipes.....	129

2.6.4.1	Metal pipes with mineral wool insulation according to Table 3.....	129
2.6.4.1.1	Steel pipes with mineral wool insulation according to Table 3	130
2.6.4.1.2	Metal pipes with mineral wool insulation according to Table 3.....	133
2.6.4.2	Metal pipes with foamed elastomeric insulation according Table 4 and Hilti Firestop Bandage CFS-B,.....	135
2.6.4.2.1	Steel pipes with foamed elastomeric insulation according Table 4 and Hilti Firestop Bandage CFS-B	135
2.6.4.2.2	Stainless steel pipes with foamed elastomeric insulation according Table 4 and Hilti Firestop Bandage CFS-B.....	136
2.6.4.2.3	Copper pipes with foamed elastomeric insulation according Table 4 and Hilti Firestop Bandage CFS-B.....	136
2.6.4.3	Metal pipes with foamed elastomeric insulation according Table 4 and Hilti Firestop Bandage CFS-B and additional protection.....	137
2.6.5	Plastic pipes with Hilti Firestop Collar CFS-C P.....	138
2.6.5.1	PVC-U pipes (C) according to EN ISO 1452-2, EN ISO 15493, DIN 8061/8062 with Hilti Firestop Collar CFS-C P.....	139
2.6.5.2	PE pipes (C) according to EN ISO 15494, DIN 8074/8075 with Hilti Firestop Collar CFS-C P.....	140
	PE pipes (C) according to EN ISO 15494, DIN 8074/8075 – U/U	140
2.6.5.3	PE pipes (C) according to EN 1519 ¹⁸ with Hilti Firestop Collar CFS-C P.....	141
2.6.5.4	PE-S2 pipes “Geberit Silent-db20” with Hilti Firestop Collar CFS-C P	142
2.6.5.5	PE-HD 100 RC pipes “Wavin TS”– U/C with Hilti Firestop Collar CFS-C P	143
2.6.5.6	Non-regulated PP pipes with Hilti Firestop Collar CFS-C P	143
2.6.5.6.1	PP pipes , non regulated.....	143
2.6.5.6.2	PP pipes “Raupiano Plus”– U/U	144
2.6.5.6.3	PP pipes „Skolan-dB“– U/U	144
2.6.5.6.4	PP pipes “Wavin AS” or “Phonex AS”– U/U	144
2.6.5.6.5	PP pipes “Wavin SiTech”– U/U.....	144
2.6.5.6.6	Non-regulated PP pipes – C/U	145
2.6.5.7	PP pipes according to EN ISO 15874 and/or DIN 8077/8078 with Hilti Firestop Collar CFS-C P.....	146
2.6.5.7.1	PP-H pipes “PROGEF standard pipe” according DIN 8077/8078 – U/U	146
2.6.5.7.2	PP-H 100 pipes “Dekaprop Industry pipes” according DIN 8077/8078 – U/U	146
2.6.5.7.3	PP-R pipes “Fusiotherm” according EN ISO 15874 – U/U.....	146
2.6.5.8	PP pipes according to EN ISO 15874 and/or DIN 8077/8078 with Hilti Firestop Collar CFS-C P.....	147
2.6.5.8.1	PP-H pipes “PROGEF standard pipe” according DIN 8077/8078 – U/C	147
2.6.5.8.2	PP-R pipes “Fusiotherm” according EN ISO 15874 – U/C.....	147
2.6.5.8.3	PP-R FS pipes “Firestop” according EN ISO 15874 and DIN 8077/8078– U/C	147
2.6.5.9	ABS/PUR/PE-HD pipes “Coolfit”– U/C with Hilti Firestop Collar CFS-C P.....	147
2.6.5.10	Special pipes with Hilti Firestop Collar CFS-C P.....	148
2.6.6	Plastic pipes with foamed elastomeric insulation according to Table 4 and Hilti Firestop Collar CFS-C P	150
2.6.6.1	Pipes (C) with continued insulation (D) – sustained – U/C.....	151
2.6.6.1.1	PP pipes “Fusiotherm SDR 11”	151
2.6.6.1.2	PP pipes “Fusiotherm Faser SDR 7.4/S3.2”	152
2.6.6.1.3	PE-100RC pipes “ Wavin TS”	152

2.6.6.1.4	PE-Xa pipes “Rautitan flex”	152
2.6.6.1.5	PP pipes “Climatherm Faserverbundrohr”	154
2.6.6.1.6	PP pipes “Firestop”	154
2.6.6.1.7	PVC-C pipes “Friatherm starr”	154
2.6.6.2	Pipes (C) with local insulation (D) – sustained – U/C	155
2.6.6.2.1	PP pipes “Fusiotherm SDR 11”	155
2.6.6.2.2	PP pipes “Fusiotherm Faser SDR 7.4/S3.2”	155
2.6.6.2.3	PE-100RC pipes “Wavin TS”	156
2.6.6.2.4	PE-Xa pipes “Rautitan flex”	156
2.6.6.2.5	PP pipes “Climatherm Faserverbundrohr”	157
2.6.6.2.6	PP pipes “Firestop”	157
2.6.6.2.7	PVC-C pipes “Friatherm starr”	157
2.6.7	Plastic pipes with Hilti Firestop Collar CFS-C	158
2.6.7.1	PVC-U pipes (C) according to EN ISO 1452-2, EN ISO 15493, DIN 8061/8062 – U/C	158
2.6.7.2	PE pipes (C) according to EN ISO 15494, DIN 8074/8075	158
2.6.7.3	PE-100 pipes, EN 12666, Geberit Silent dB20	158
2.6.7.4	PP-R pipes, „Aquatherm Green”, acc. EN 15874 and DIN 8077/78, with additional protection AP9 see 2.6.5 and 2.6.6, offset = 80mm	159
2.6.7.5	PP-R pipes, „Aquatherm Blue”, acc. EN 15874 and DIN 8077/78, with additional protection AP9 see 2.6.5 and 2.6.6, offset = 80mm	159
2.6.7.6	PVC-U pipes, Georg Fischer “Dekadur” acc. DIN 8061/62, with additional protection AP9 see 2.6.5 and 2.6.6, offset = 80mm	159
2.6.8	Plastic pipes, sealed with Hilti Firestop Collar Endless CFS-C EL	160
2.6.8.1	PE pipes acc. EN 1519-1, EN12201-2 and EN 12666-1 and ABS-pipes acc. EN 1455-1 and SAN+PVC-pipes acc. EN 1565-1	161
2.6.8.2	ABS pipes acc. EN 1455-1, EN 15493 and SAN+PVC-pipes acc. EN 1565-1	161
2.6.8.3	PE pipes acc. EN 15494, EN12201-2 and DIN 8074/75	162
2.6.8.4	PVC pipes acc. EN 1452-1, EN1329-1, EN1453-1, EN 1566-1, EN ISO 15493 and DIN 8061/62	162
2.6.8.5	PP pipes, non-regulated	163
2.6.8.6	PP pipes acc. EN 1451-1 and DIN 8077/78	163
2.6.8.7	PE pipes, non-regulated (Geberit Silent dB20)	164
2.6.8.8	PVC-pipes, non-regulated (Friatec Friaphon)	164
2.6.9	Plastic pipes with Hilti Firestop Wrap CFS-W	165
2.6.9.1	PVC-U pipes with Hilti Firestop Wrap CFS-W	165
2.6.9.2	PE pipes with Hilti Firestop Wrap CFS-W	167
2.6.8.2.1	PE pipes (C) according to EN 1519 ¹⁸ - U/C Additional protection AP ₉	167
2.6.8.2.2	PE pipes (C) according to EN ISO 15494, DIN 8074/8075 – U/U, Additional protection, AP ₉	167
2.6.8.2.3	PE-S2 pipes “Geberit Silent-db20”	168
2.6.9.3	PP pipes according EN 1451-1 with Hilti Firestop Wrap CFS-W – C/U	168
2.6.8.3.1	PP pipes “Wavin AS” or “Phonex AS”	168
2.6.8.3.2	PP/PP-MV/PP pipes “Polokal NG”	168
2.6.8.3.3	PP/Porolen/PP pipes “Polokal 3S”	168
2.6.8.3.4	PP-R pipes “Aquatherm Green pipe”	169
2.6.10	Plastic pipes with Hilti Firestop Wrap CFS-W P in rigid floor	170

2.6.10.1	<i>Pipes, sealed with Hilti Firestop Wrap CFS-W P – seal design variations in floor..</i>	172
2.6.10.2	<i>Pipe insulation</i>	175
2.6.10.3	<i>Layer groups</i>	176
2.6.10.4	<i>Separation of penetrations</i>	177
2.6.10.5	<i>Plastic pipes sealed with Hilti Firestop Wrap CFS-W P penetrating a double board seal CFS-CT.....</i>	178
2.6.10.5.1	<i>PE - pipes according to EN 1519-1, EN 12666-1, EN 12201-2 for EI 90-U/U</i>	178
2.6.10.5.2	<i>PE - pipes according to EN 1519-1, EN 12666-1, EN 12201-2 for EI 120-U/U</i>	179
2.6.10.5.3	<i>PE - pipes (isolated) according to EN 1519-1, EN 12666-1, EN 12201-2 for EI 90-U/U</i>	180
2.6.10.5.4	<i>PE – pipes (Geberit Silent dB20) for EI 90-U/U</i>	181
2.6.10.5.5	<i>PE – pipes (Geberit Silent dB20) for EI 120-U/U</i>	182
2.6.10.5.6	<i>PE – pipes according EN 15494 for EI 90-U/C.....</i>	183
2.6.10.5.7	<i>PE pipes according EN 15494 for EI 120-U/C.....</i>	184
2.6.10.5.8	<i>PP-pipes, non-regulated, for EI 90-U/U.....</i>	185
2.6.10.5.9	<i>PP-pipes, non-regulated, for EI 120-U/U.....</i>	186
2.6.10.5.10	<i>PVC-pipes according EN 1452-1 for EI 90-U/U</i>	187
2.6.10.5.11	<i>PVC-pipes according EN 1452-1 for EI 120-U/C</i>	188
2.6.11	<i>Aluminium composite pipes with elastomeric insulation, penetrating CFS-CT double board seal, provided with Hilti firestop wrap CFS-W P and gap filler in floor.....</i>	190
2.6.11.1	<i>Rehau Rautitan Stabil, penetrating CFS-CT, sealed with CFS-W P.....</i>	190
2.6.11.2	<i>Uponor MLC, penetrating CFS-CT, sealed with CFS-W P</i>	191
2.6.11.3	<i>Kekelit Kelox, penetrating CFS-CT, sealed with CFS-W P</i>	192
2.6.11.4	<i>Geberit Mepla, penetrating CFS-CT, sealed with CFS-W P</i>	193
2.6.11.5	<i>Viega Sanfix Fosta and Viega Raxofix, penetrating CFS-CT, sealed with CFS-W P</i>	194
2.6.11.6	<i>Geberit PushFit ML, penetrating CFS-CT, sealed with CFS-W P</i>	196
2.6.12	<i>Metal pipes with elastomeric insulation, penetrating a CFS-CT double board seal, provided with Hilti firestop wrap CFS-W P and gap filler</i>	197
2.6.12.1	<i>Isolated copper pipes, penetrating CFS-CT, sealed with CFS-W P</i>	197
2.6.12.2	<i>Isolated steel pipes, penetrating CFS-CT, sealed with CFS-W P</i>	198
2.6.13	<i>Al-Composite pipes with foamed elastomeric insulation according to Table 4 and Hilti Firestop Collar CFS-C P.....</i>	200
2.6.13.1	<i>Pipes (C) with local insulation (D) – sustained – U/C</i>	200
2.6.13.2	<i>Pipes (C) with continued insulation (D) – sustained – U/C.....</i>	201
2.6.14	<i>Al-composite pipes and plastic pipes with mineral wool insulation according to Table 3</i>	202
2.6.14.1	<i>Aluminum composite pipes (C) with continued insulation (D) – sustained – U/C</i>	202
2.6.10.2	<i>PE pipes (C) with continued insulation (D) – sustained – U/C</i>	203
2.7	<i>Rigid walls according to 2.1 f) minimum thickness 250 mm.....</i>	204
2.7.1	<i>Blank seal (no services) *</i>	205
3	<i>ANNEX 3 Reference Documents</i>	206
3.1	<i>References to standards mentioned in the ETA:</i>	206
3.2	<i>Other referenced documents</i>	207
4	<i>ANNEX 4 Abbreviations used in drawings.....</i>	208

Specific parts

1 Technical description of the product

1.1 Definition of the construction product

This European Technical Assessment refers to a Firestop coating for use in penetration seals with the designation "Hilti Firestop Coating CFS-CT". Hilti Firestop Coating CFS-CT may be either applied on site onto a MW board as specified in Table 1 or used in the form of the Hilti Firestop Board CFS-CT B (pre-coated with Hilti Firestop Coating CFS-CT).

Hilti Firestop Coating CFS-CT is a white, ablative 1-component product and is composed essentially of filling substances and an acrylic binder.

Hilti Firestop Coating CFS-CT is supplied in pails/buckets of different size. The coating is sprayed or painted on mineral wool boards and partially on the services (for detail see Annex 2). For the installation procedure see Annex 3.1.

Hilti Firestop Board CFS-CT B is a mineral wool board pre-coated with Hilti Firestop Coating CFS-CT. The board is supplied in of the dimensions 1000 x 600 x 50 mm. The thickness of the coating is 0.7 mm. For the installation procedure see Annex 3.2.

Ancillary products referred to in this European Technical Assessment within the framework of evaluating resistance to fire (see Annexes 1 and 2) are not covered by this ETA and cannot be CE-marked on the basis of it.

2 Specification of the intended use(s) in accordance with the applicable European Assessment Document (hereinafter EAD)

2.1 Intended use

Hilti Firestop Coating CFS-CT is intended to form part of a penetration seal ("Hilti Firestop Double Board Seal"), which is used to maintain the fire resistance of a separating element (wall or floor) when and where services pass through.

The "Hilti Firestop Double Board Seal" is made of two adjacent mineral wool (MW) boards, the Hilti Firestop Coating CFS-CT, the Hilti Firestop Acrylic Sealant CFS-S ACR (to close any gaps between the opening edges and the seal or between services and the seal) and other components as listed in Annex 1 depending on the type of services included.

The seal may be either formed by applying Hilti Firestop Coating CFS-CT on site onto a MW board as specified in Table 1 or by using the pre-coated MW board Hilti Firestop Board CFS-CT B 1S (coated on one face with Hilti Firestop Coating CFS-CT) or Hilti Firestop Board CFS-CT B 2S (coated on both faces with Hilti Firestop Coating CFS-CT). Wherever this document references Hilti Firestop Board CFS-CT B 1S, the Hilti Firestop Board CFS-CT B 2S, which is the pre-coated board for single board seals (for further details see ETA-11/0428) may also be used.

The separating elements must be classified in accordance with EN 13501-2 for the required fire resistance period or fulfil the requirements of the relevant Eurocode. This ETA does not cover use of this product as a penetration seal in sandwich panel constructions.

Hilti Firestop Double Board Seal may be used to provide a penetration seal with the following specific services, single, multiple or mixed:

Blank seal	No services, as given in Annex 2
Cables	Services as given in Annex 2
Metal pipes	Services as given in Annex 2
Plastic pipes	Services as given in Annex 2
Composite pipes	Services as given in Annex 2
Mixed (combination)	Services as given in Annex 2

For the maximum seal size see Annex 2.

Penetration seals require a minimum separation of 200 mm. For minimum distances between services within a penetration seal (multiple or mixed penetration seal) see Annex 2.

Maximum distance [mm] from surface of the building element for first support / fixing of services: see Annex 2.

Annex 2 gives details of penetration seals for which fire resistance tests were carried out. This ETA covers assemblies installed in accordance with the provisions given in 4.3 and Annex 3.

Although a penetration seal is intended for indoor applications only, the construction process may result in it being subjected to more exposed conditions for a period before the building envelope is closed. For this case provisions shall be made to protect temporarily exposed penetration seals according to the instructions of the manufacturer.

The specific elements of construction that Hilti Firestop Coating CFS-CT may be used to provide a penetration seal in, are as follows:

- a) Flexible walls: The wall must have a minimum thickness of 100, 112 or 135 mm, respectively (for detail see Annex 2) and comprises timber or steel studs lined on both faces with one or several layers of boards of minimum 25 mm overall thickness on both sides of the wall. For timber stud walls there must be a minimum distance of 100 mm from the seal to any stud and the cavity between stud and seal must be filled with minimum 100 mm insulation of Class A1 or A2 (in accordance with EN 13501-1) in the cavity between stud and seal. An aperture framing must be installed made of C-studs and boards that have been used for the lining of the wall, minimum thickness of the board 12.5 mm.
- b) Rigid walls: The wall must have a minimum thickness of 100 or 135 mm, respectively (for detail see Annex 2) and comprise concrete, blockwork or masonry, with a minimum density of 650 kg/m³.
- c) Rigid walls: The wall must have a minimum thickness of 150 mm and comprise concrete, blockwork or masonry, with a minimum density of 600 kg/m³.
- d) Rigid walls: The wall must have a minimum thickness of 150 mm and comprise concrete, blockwork or masonry, with a minimum density of 760 kg/m³.
- e) Rigid floors: The floor must have a minimum thickness of 150 mm and comprise aerated concrete or concrete with a minimum density of 670 kg/m³.
- f) Rigid walls: The wall must have a minimum thickness of 250 mm and comprise concrete, blockwork or masonry, with a minimum density of 500 kg/m³.
- g) Rigid floors: The floor must have a minimum thickness of 150 mm and comprise aerated concrete or concrete with a minimum density of 550 kg/m³.

2.2 Use category

Hilti Firestop Coating CFS-CT fulfils the requirements of use condition Y2 in accordance with EAD 350454-00-1104, September 2017, Section 1.2.1 (intended for use at temperatures between -20 °C and + 70°C, but with no exposure to rain nor UV).

2.3 Working life

The assessment methods included or referred to in this EAD have been written based on the manufacturer's request to take into account a working life of the product for the intended use of 25 years when installed in the works provided that the product is subject to appropriate installation, use and maintenance. These provisions are based upon the current state of the art and the available knowledge and experience.

The indication given as to the working life of the construction product cannot be interpreted as a guarantee neither given by the product manufacturer or his representative nor by EOTA when issuing the EAD nor by the Technical Assessment Body (RISE Research Institutes of Sweden AB), but are regarded only as a means for expressing the expected economically reasonable working life of the product.

3 Performance of the product and references to the methods used for its assessment

3.1 Essential characteristics and their performance

Basic requirement for construction work	Essential characteristics	Performance
BWR 1 - Mechanical resistance and stability	None	Clause 3.1.1
BWR 2 - Safety in case of fire	Reaction to fire	Clause 3.1.2.1
	Resistance to fire	Clause 3.1.2.2 and Annex 2
BWR 3 - Hygiene, health and the environment	Air permeability (material property)	Clause 3.1.3.1
	Water permeability (material property)	Clause 3.1.3.2
	Content and/or release of dangerous substances	Clause 3.1.3.3
BWR 4 - Safety in use	Mechanical resistance and stability	Clause 3.1.4.1
	Resistance to impact / movement	Clause 3.1.4.2
	Adhesion	Clause 3.1.4.3
	Durability - use category	Clause 3.1.4.4
	Durability -flexibility	Clause 3.1.4.5
	Durability - Compatibility	Clause 3.1.4.6
BWR 5 - Protection against noise	Airborne sound insulation	Clause 3.1.5.1
BWR 6 - Energy economy and heat retention	Thermal properties	Clause 3.1.6.1
	Water vapor permeability	Clause 3.1.6.2
BWR 7- Sustainable use of natural resources	None	Clause 3.1.7

3.1.1 Mechanical resistance and stability (BWR 1)

Not relevant, no performance assessed (NPA).

3.1.2 Safety in case of fire (BWR 2)

3.1.2.1 Reaction to fire

Hilti Firestop Coating CFS-CT on a MW board fulfils the requirements for reaction to fire class D- s2, d0 according to EN 13501-1. The reaction to fire classification of the mineral wool board used for Hilti Firestop Board CFS-CT B 1S and CFS-CT B 2S is class A1.

3.1.2.2 Resistance to fire

The resistance to fire performance according to EN 13501-2 of penetration seals "Hilti Firestop Double Board Seal" incorporating Hilti Firestop Coating CFS-CT with a mineral wool board according to Table 1 or Hilti Firestop Coated Board CFS-CT B is given in Annex 2.

Information on ancillary products which were tested within the framework of this European Technical Assessment for evaluating resistance to fire are given in Annex 1.

Any changes in the material, the composition, the dimensions or the properties of the ancillary products shall be notified to SP Certification without delay, which will decide whether a new assessment will be necessary.

3.1.3 Hygiene, health and environment (BWR 3)

3.1.3.1 Air permeability

The air permeability was measured according to EN 1026:2016-03. A sample of a 1-sided coated board CFS-CT B 1S with the size of 250 mm x 250 mm was installed in a aerated concrete wall with thickness 150 mm. CP 606 was used between the mineral wool board and the concrete opening.

The air permeability was tested on the test chamber side in accordance with EN 1026 at positive and negative pressures in steps up to a maximum test pressure difference of 600 Pa. The test specimen was exposed to three pressure pulses with +660 Pa and -660 Pa. This is followed by measurement of the airflow rate at the following pressure differences [Pa]: 10, 25, 50, 75, 100, 150, 200, 250, 300, 450, 600.

Up to 600 Pa no air flow was measurable.

3.1.3.2 Water permeability

The water permeability has been tested according to Annex C of EAD 350454-00-1104, September 2017, Annex C. The specimen consisted of 0.7 mm Hilti Firestop Coating CFS-CT (dry film thickness) on mineral wool.

Test result: Water tight to 1000 mm head of water or water tight to 9806 Pa.

3.1.3.3 Release of dangerous substances

The release of semi-volatile organic compounds (SVOC) and volatile organic compounds (VOC) has been determined according to EAD 350454-00-1104 clause 2.2.5.1 and prEN 16516:2015. The loading factor used for emission testing was 0,05m²/m³.

The total emission of SVOC of "Hilti Firestop Product" after 3 days is less than 0,005 mg/m³.

The total emission of SVOC of "Hilti Firestop Product" after 28 days is 0,005 mg/m³.

The total emission of VOC of "Hilti Firestop Product" after 3 days is 820 mg/m³.

The total emission of VOC of "Hilti Firestop Product" after 28 days is 290 mg/m³.

3.1.4 Safety in use (BWR 4)

3.1.4.1 Mechanical resistance and stability

In impact tests according to EOTA TR001 the requirements for the highest risk zone type (Type IV) have been fulfilled as defined for internal walls in EOTA TR 001 A.1 for safety in use (500 Nm soft body impact, 10 Nm hard body impact) as well as serviceability (120 Nm soft body impact, 6 Nm hard body impact). The maximum dimension of the penetration seal is 1.0 x 1.5 m. The results are therefore valid for all seal sizes given in Annex 2.

In case of horizontal penetration seals precautions have to be taken to prevent a person stepping onto the penetration seal from falling through the seal.

3.1.4.2 Resistance to impact and movement

See clause 3.1.4.1

3.1.4.3 Adhesion

See clause 3.1.4.1

3.1.4.4 Durability – use category

Hilti Firestop Coating CFS-CT fulfils the requirements of use category Y₂ in accordance with EAD 350454-00-1104, September 2017, Section 2.2.9.

Since the requirements for type Y₂ are met, also the requirements for type Z₁ and Z₂ are fulfilled.

Type Y₂: Products intended for use at temperatures between -20 °C and + 70°C, but with no exposure to rain nor UV.

Type Z₁: Products intended for use at internal conditions with high humidity, excluding temperatures below 0°C.

Type Z₂: Products intended for uses at internal conditions with humidity classes other than Z₁, excluding temperatures below 0°C.

3.1.4.5 Durability - Flexibility Hilti Firestop Coating CFS-CT

The flexibility of Hilti Firestop Coating CFS-CT has been tested in accordance with EN ISO 1519 with the result of no crack formation on a mandrel of 2 mm diameter for a coating thickness of 1.0 mm.

3.1.4.6 Durability - Compatibility of Hilti Firestop Coating CFS-CT with metals/plastics

Hilti Firestop Coating CFS-CT has been tested in accordance with EOTA Technical Report TR024, 4.3.6 for compatibility in permanent contact with metals and plastics with the result of no interaction with copper, galvanized steel and stainless steel as well as PE, PVC and ABS.

3.1.5 Protection against noise (BWR 5)

3.1.5.1 Airborne sound insulation

The test report for noise reduction was done according to EN ISO 140-1, EN ISO 20140-3, EN ISO 20140-10. The test results are expressed in accordance with EN ISO 717-1.

According to these tests reports:

The single number ratings for a flexible wall are:

	CFS-CT on MW board 2 x 50 mm	CFS-CT on MW board 2 x 50 mm
Nominal density of board [kg/m ³]	140	160
No of board faced coated	1	1
Air gap between boards [mm]	55	55
Specimen size [mm x mm]	400 x 500	400 x 500
D _{n,e,w} (C; C _{tr}) [dB]	58 (-4; -8)	60 (-4; -9)
R _w (C; C _{tr}) [dB] referring to S = 1,88 m ²	51 (-4; -8)	53 (-4; -9)

Test set up

The structure of the flexible wall was as follows: 2 x 12,5 mm plasterboard on one side of a 50 mm metal stud with 40 mm mineral wool. 5 mm separating joint as air gap. 50 mm metal stud with 40 mm mineral wool. 2 x 12,5 mm plasterboard.

Mineral wool boards with different densities were coated with 0,7 mm CFS-CT coating (1 mm wet thickness). Joints around the mineral wool board were closed with a sealant.

3.1.6 Energy economy and heat retention (BWR 6)

3.1.6.1 Thermal properties

Hilti Firestop Coating CFS-CT

The insulation performance of a mineral wool slab is slightly reduced by the coating, 2.2% with one-sided coating, 3.0 to 3.4% with double-sided coating. This has to be considered when selecting a mineral wool board if a required regulatory nominal λ -value has to be achieved.

Hilti Firestop Board CFS-CT B 1S

Thermal conductivity coefficient according to EN 12667 for a double layer of the boards:

$\lambda_{10} = 0.039 \text{ W/mK}$.

3.1.6.2 Water vapor permeability

Performance not assessed (NPA).

3.1.7 Sustainable use of natural resources (BWR 7)

Not relevant, no performance assessed (NPA).

4 Assessment and verification of constancy of performance (hereinafter AVCP) system applied, with reference to its legal base

According to the decision 1999/454/EC of the - Commission decision of 22 June 1999 (OJ L 178/52 of 14/07/99, p. 3), as amended by Decision of the Commission 2001/596/EC of 8 January 2001 (OJ L 209/33 of 2/8/2001, p.2) the system of assessment and verification of constancy of performance (see Annex V to the regulation (EU) No 305/2011 and EC delegated act no 568/2014 of 18 February 2014) given in the following table apply:

Product(s)	Intended use(s)	Level(s) or class(es)	System(s)
Fire stopping and fire sealing products	For fire compartmentation and/or fire protection or fire performance	Any	1
Fire stopping and fire sealing products	For uses subject to reaction to fire regulations	A, D, E, F	4

5 Technical details necessary for the implementation of the AVCP system, as provided for in the applicable EAD

Technical details necessary for the implementation of the AVCP system are laid down in the control plan deposited at RISE.

Issued in Borås on 22.09.2021
By RISE Research Institutes of Sweden AB

Martin Tillander
Product Certification Manager

1 ANNEX 1 Description of Product(s) and Product Literature

1.1 Products

1.1.1 Hilti Firestop Coating CFS-CT

A detailed specification of the product is contained in document "Identification / Product Specification relating to the European Technical Assessment ETA-11/0428 and ETA-11/0429 - Hilti Firestop Coating CFS-CT" which is a non-public part of this ETA.

The Control Plan is defined in document "Control Plan" relating to the European Technical Assessment ETA-11/0428 and ETA-11/0429 - Hilti Firestop Coating CFS-CT" which is a non-public part of this ETA.

1.1.2 Hilti Firestop Board CFS-CT B 1S

Hilti Firestop Board CFS-CT B 1S is a mineral wool board pre-coated on one face with Hilti Firestop Coating CFS-CT. The thickness of the coating is 0.7 mm.

A detailed specification of the product is contained in document "Identification / Product Specification relating to the European Technical Assessment ETA-11/0428 and ETA 0429 - Hilti Firestop Board CFS-CT B 1S" which is a non-public part of this ETA.

The "Control Plan" is defined in document "Control Plan" relating to the European Technical Assessment ETA-11/0428 and ETA-10/0429 - Hilti Firestop Board CFS-CT B 1S" which is a non-public part of this ETA.

1.1.3 Hilti Firestop Board CFS-CT B 2S

Hilti Firestop Board CFS-CT B 2S is a mineral wool board pre-coated on both faces with Hilti Firestop Coating CFS-CT. The thickness of the coating is 0.7 mm.

A detailed specification of the product is contained in document "Identification / Product Specification relating to the European Technical Assessment ETA-11/0428 and ETA-11/0429 - Hilti Firestop Board CFS-CT B 2S" which is a non-public part of this ETA.

The "Control Plan" is defined in document "Control Plan relating to the European Technical Assessment ETA-11/0428 and ETA-10/0429 - Hilti Firestop Board CFS-CT B 2S" which is a non-public part of this ETA.

Table 1: Specification for mineral wool boards suitable for being used together with Hilti Firestop Coating CFS-CT

Manufacturer	Product designation
Flumroc	Flumroc 341
Isover	Fireprotect 150
Isover	Orsil Pyro
Isover	Orsil S
Isover	Orsil T
Isover	Protect BSP 150
Isover	Stropoterm
Knauf	HERALAN BS-15
Knauf	HERALAN DDP-S
Knauf	HERALAN DP-15
Paroc	FPS 14

Table 1 (cont.): Specification for mineral wool boards suitable for being used together with Hilti Firestop Coating CFS-CT

Manufacturer	Product designation
Paroc	FPS 17
Paroc	Pyrotech Slab 140
Paroc	Pyrotech Slab 160
Rockwool	Hardrock II, Hardrock 040
Rockwool	RP-XV
Rockwool	RPB-15, ProRox SL 980

1.2 Ancillary Products

1.2.1 Hilti Firestop Acrylic Sealant CFS-S ACR

For specification and further details see ETA-10/0292

1.2.2 Hilti Firestop Collar CFS-C

For specification and further details see ETA-10/0403

1.2.3 Hilti Firestop Collar CFS-C P

For specification and further details see ETA-10/0404

1.2.4 Hilti Firestop Collar Endless CFS-C EL

For specification and further details see ETA-14/0085

1.2.5 Hilti Firestop Bandage CFS-B

For specification and further details see ETA-20/0993

1.2.6 Hilti Firestop Wrap CFS-W

For specification and further details see ETA-10/0405

1.2.7 Hilti Firestop Wrap CFS-W P

For specification and further details see ETA-20/0989.

1.2.8 Hilti Firestop Sleeve CFS-SL M and Hilti Firestop Sleeve CFS-SL GA

For specification and further details see ETA-11/0153 and ETA-20/1234

1.2.9 Fixing for Hilti Firestop Collars CFS-C and CFS-C P

- Threaded rods M8, galvanized, minimum strength category 4.6
- Nuts M8, galvanized (e.g. according to EN ISO 4032)
- Washers:
 - at a collar hook: A 8.4-28 s = 2 mm, galvanized (e.g. according to EN ISO 7089)
 - at the top side of a floor seal: A 8.4-40 s = 3 mm, galvanized (e.g. according to EN ISO 7089)

1.2.10 Fixing for Hilti Firestop Collar Endless CFS-C EL

Hilti Firestop Collar Endless CFS-C EL (AR;R) to be installed against the wall or floor utilising the specified number of fixing hooks. The required number and type of hooks (short hooks only) is shown below:

Nominal pipe Outside diameter dR _c (mm)	Numbers of short hooks		
	Max. insulation thickness (Insulation is an acoustical insulation)		
	0 mm	4 mm	9 mm
16	---	---	2
32	2	2	2
40	2	2	2
50	2	2	2
56	3	3	3
63	3	3	3
75	3	3	3
90	3	3	3
110	3	3	3

Hooks for CFS-C EL to seal plastic pipes penetrating coated boards CFS-CT B 1S in flexible or rigid walls:

- have to be fixed by using a threaded rod minimum M6 with flat washer and nut on both sides of the wall.

1.2.11 Mineral wool products for additional protection

Table 2: Specification for mineral wool products suitable for being used as additional protection for cables/cable supports and metal pipes according to 1.2 (relevant for Annex 2.6.4.1)

Characteristic	Specification	Unit
Mineral wool according to EN 14303		
Reaction to fire class according to EN 13501-1	A1 or A2	-
Thermal conductivity at 20°C	≤ 0.040	W/(mK)
Density	35 - 45	kg/m ³
Surface	Al-foil faced on one side	-

The following list contains suitable products for additional protection but may not be exhaustive:

Manufacturer	Product designation
Isover	Ultimate U TFA 34
Knauf	Lamella Forte LLMF AluR
Paroc	Lamella Mat 35 Alu Coat
Rockwool	Klimafix
Rockwool	Klimarock
Rockwool	Rockwool 133 (Lamella mat)

1.2.12 Pipe insulation products

Table 3: Specification for mineral wool products suitable for being used as pipe insulation

Interrupted insulation
Mineral wool according to EN 14303, class A1 or A2 according to EN 13501-1, Al-faced

Sustained insulation	
Manufacturer	Product designation
Isover	Coquilla AT-LR
Isover	Protect BSR 90 alu
Paroc	Section AluCoat T
Rockwool	Conlit Pipe sections
Rockwool	Klimarock
Rockwool	RS 800 pipe sections
TP Termoprodukt	TP-Protect RS 1, TP-Protect RS 105, TP-Protect RS 120, TP-Protect RS 150

Table 4: Specification for foamed elastomeric insulation products suitable for being used as pipe insulation

Manufacturer	Product designation
Armacell International GmbH	Armaflex AF, Armaflex SH, Armaflex Ultima, Armaflex XG, Armaflex NH, Armaflex HT
NMC Group	Insul-Tube H-Plus (nmc),
Kaimann GmbH	Kaiflex KK plus, Kaiflex KK, Kaiflex HF plus
L'Isolante K-Flex	l'Isolante K-Flex ECO, l'Isolante K-Flex ST Frigo
Aeroflex NMC Deutschland	Aeroflex HF
Solar, Halkida, Greece	3i - Isopipe HAT
HAT Isolierung Cosmo	Conel Flex HT
Union Foam S.p.A. Bellusco, Italia	Eurobatex
Würth	Flexen Kälteschlauch
Isidem Insulation Istanbul, Turkey	Isidem Coolflex AF

Named material may be used as insulation hose, bandage/wrap or plates. If an additional protection AP_x is used, it should be made of the same elastomeric material as the foamed elastomeric pipe isolation itself.

1.3 Technical product literature

- Technical data sheet Hilti Firestop Double Board Seal – Hilti Firestop Coating CFS-CT (including all components and ancillary products as defined in 1.1 and 1.2).

1.4 Installation

1.4.1 Installation of the penetration seal "Hilti Firestop Double Board Seal", when using a MW board according to Table 1 and Hilti Firestop Coating CFS-CT

The installation should be conducted as follows:

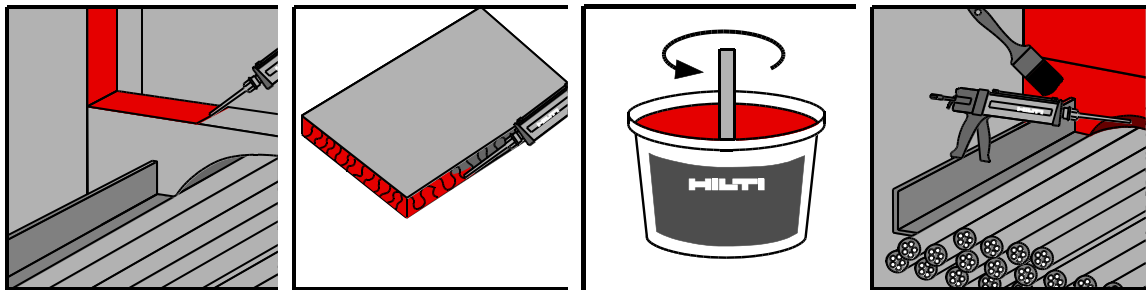
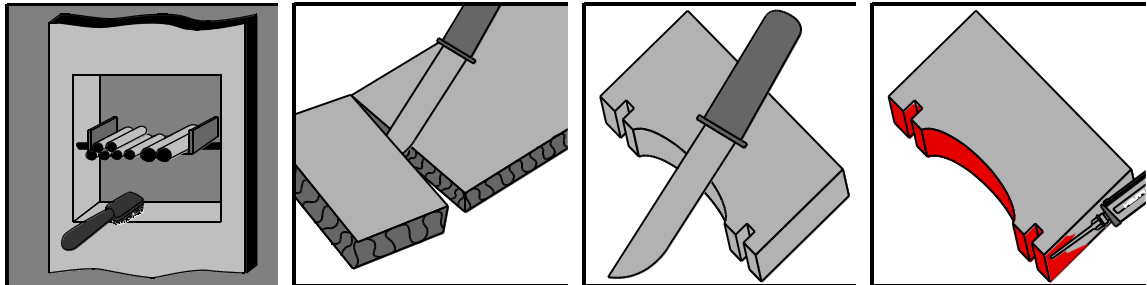

- In case AP₁, AP₂ or AP₃ is required:

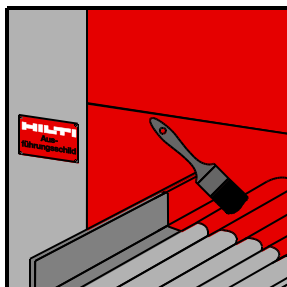

- In case AP₄ or AP₅ is required:

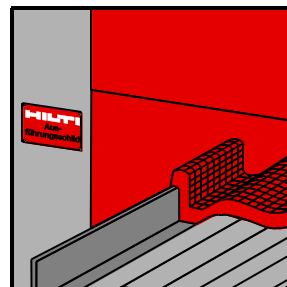

1.4.2 Installation of the penetration seal "Hilti Firestop Double Board Seal", when using the pre-coated boards Hilti Firestop Board CFS-CT B 1S or CFS-CT B 2S

The installation should be conducted as follows:

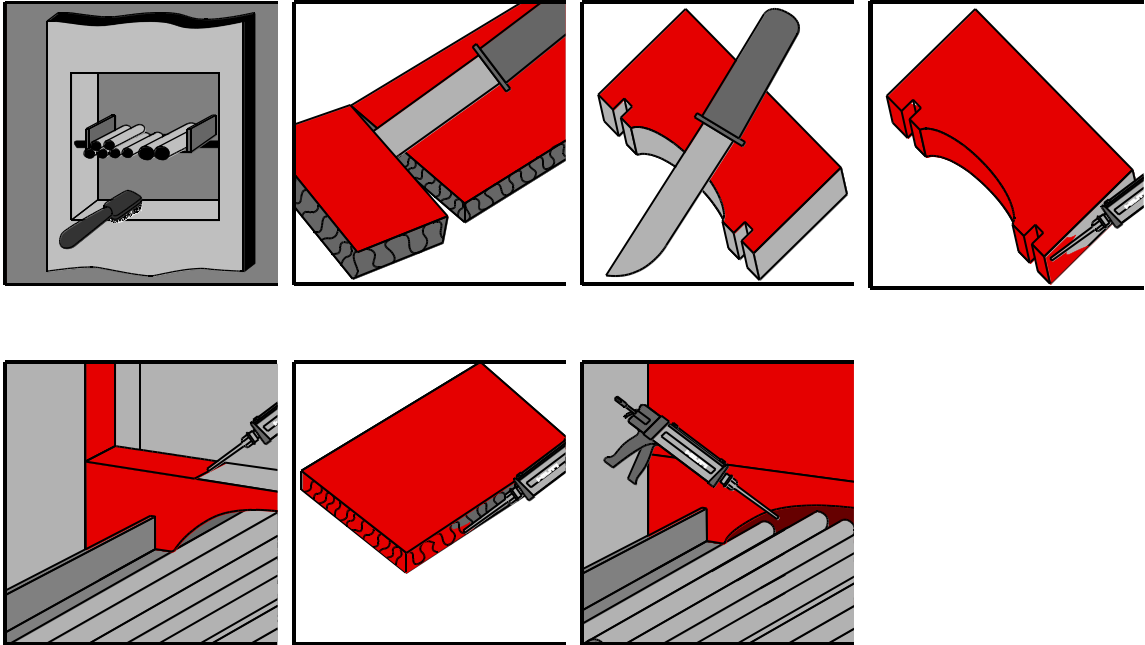

- In case AP₁, AP₂ or AP₃ is required:

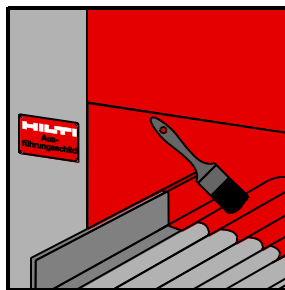
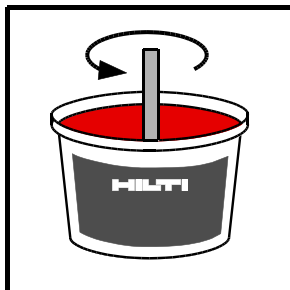

- In case AP₄ or AP₅ is required:

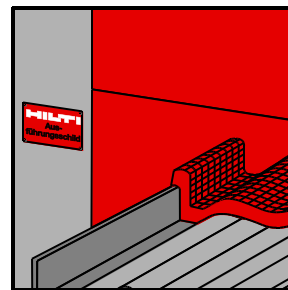

1.4.3 Application temperature

The intended application temperature range is: +5°C to +40°C

1.4.4 Re-penetration / removal of services

If single services (cables, pipes) are installed later on, a hole is drilled through the mineral wool panel and the services passed through; the remaining annular space has to be sealed with Hilti Firestop Acrylic Sealant CFS-S ACR. In case the coating has been damaged during installation of the additional service it must be repaired. Depending on the type of service and the required fire resistance additional firestopping components, e.g. Hilti Firestop Bandage CFS-B or Hilti Firestop Collars CFS-C or CFS-C P, and/or additional protections AP₁ to AP₁₀ according to 1.2 may be necessary – for details see Annex 2.

In case services are removed, the remaining hole has to be filled with mineral wool according to the specification given in Table 1 and coated with Hilti Firestop Coating CFS-CT. Before coating any gaps have to be filled with Hilti Firestop Acrylic Sealant CFS-S ACR.

1.5 Indications to the manufacturer

1.5.1 Packaging, transport and storage

In the accompanying document and/or on the packaging the manufacturer shall give information as to transport and storage.

At least the following shall be indicated: storing temperature, type of storage, maximum duration of storage and required data related to minimum temperature for transport and storage.

Storage:	Store in a dry place protected from moisture	
Storage temperature:	CFS-CT:	+5° up to max. +30°C
	CFS-CT B 1S/2S:	0° up to max. +40°C

1.5.2 Use, maintenance, repair

The fire resistance of penetration seals executed using Hilti Firestop Coating CFS-CT / Hilti Firestop Coated Boards CFS-CT B shall not be negatively affected by future changes to buildings or building elements.

The assessment of the fitness for use is based on the assumption that damaged seals are replaced or repaired. It is also assumed that replacement of components during maintenance/repair will be undertaken using materials specified by this European Technical Assessment.

2 ANNEX 2 RESISTANCE TO FIRE CLASSIFICATION OF PENETRATION SEALS HILTI FIRESTOP DOUBLE BOARD SEAL

2.1 General Information Hilti Firestop Double Board Seal

The seals may only be penetrated by the services described in Annex 2. Other parts or support constructions must not penetrate the seal.

The service support construction must be fixed to the building element containing the penetration seal or a suitable adjacent building element, on both sides of the penetration in such a manner that in the case of fire, no additional load is imposed on the seal. Furthermore it is assumed that this support is maintained on the unexposed side, for the required period of fire resistance.

Specific considerations:

- Pipes must be perpendicular to the seal surface.
- The function of the pipe seal in case of pneumatic dispatch systems, pressurised air systems etc. is guaranteed only when the systems are shut off in case of fire.
- The approval does not address any risks associated with leakage of dangerous liquids or gases caused by failure of the pipe(s) in case of fire.
- The durability assessment does not take account of the possible effect of substances permeating through the pipe on the penetration seal.

The classifications for metal, plastic and composite pipes relate to C/U (capped inside the furnace/uncapped outside), U/C (uncapped inside the furnace/capped outside) and U/U (uncapped inside the furnace/uncapped outside). For further information refer to national regulations.

2.1.1 Intended use of penetrations and reference to relevant section (list not exhaustive, other uses of pipes may be possible)				see section (Annex 2)			
Application	Penetration material	Manufacturer, product (samples)	Insulation	Flexible & rigid wall ≥ 100 mm	Flexible & rigid wall ≥ 135 mm	Rigid wall ≥ 150 mm	Rigid floor ≥ 150 mm
Cables	Sheathed			2.2.2 2.2.3		2.4.1 2.5.1	2.6.2
	Wires (non-sheathed)						
	tied bundles						
Electrical conduits	PVC, PO			2.2.4		2.4.2 2.5.2	2.6.3
Heating pipes	Copper		CI	2.2.5.1.2	2.3.1.1.2	2.4.3.2	2.6.4.1.2
			CS	2.2.5.2.3	2.3.1.2.3	2.5.3.3	2.6.4.2.3 2.6.4.3
	Steel, Stainless steel		CI	2.2.5.1.1	2.3.1.1.1	2.4.3.1	2.6.4.1.1
			CS	2.2.5.2.1 2.2.5.2.2	2.3.1.2.1 2.3.1.2.2	2.5.3.1 2.5.3.2	2.6.4.2.1 2.6.4.2.2 2.6.4.3
	Al-Composite	Geberit Mepla, PushFit KeKelit Kelox, Uponor Viega Sanfix+Raxofix Rehau: Rautitan stabil	CS	2.2.12.1-6			2.6.9 2.6.10 2.6.11.1-6
	Potable water pipes	Copper		CI	2.2.5.1.2 2.2.5.2.3	2.3.1.1.2 2.3.1.2.3	2.4.3.2 2.5.3.3
CS							
LI							
LS							
Stainless steel			CI	2.2.5.2.2	2.3.1.2.2	2.5.3.2	2.6.4.2.2

Intended use of penetrations and reference to relevant section (list not exhaustive, other uses of pipes may be possible)				see section (Annex 2)			
Application	Penetration material	Manufacturer, product (samples)	Insulation	Flexible & rigid wall ≥ 100 mm	Flexible & rigid wall ≥ 135 mm	Rigid wall ≥ 150 mm	Rigid floor ≥ 150 mm
Potable water pipes (cont.)	Al-Composite pipes	Geberit Mepla, PushFit KeKelit Kelox, Uponor Viega Sanfix+Raxofix Rehau: Rautitan stabil	CS	2.2.12.1-6			2.6.9 2.6.10 2.6.11.1-6
			LS	2.2.11.2 2.2.12.2			
	PE-HD 100 RC	Wavin: Wavin TS	CS	2.2.6.5 2.2.7.2.4			2.6.6.1.3
			LS	2.2.7.4.4			2.6.6.2.3
	PE-X	Rehau: Rautitan flex	CS	2.2.7.2.1			2.6.6.1.4
			LS	2.2.7.4.1			2.6.6.2.4
	PP	Aquatherm: Fusiotherm	CS	2.2.7.2.2 2.2.7.2.3			2.6.6.1.1 2.6.6.1.2
			LS	2.2.7.4.2 2.2.7.4.3			2.6.6.2.1 2.6.6.2.2
	PB	Geberit PushFit PB	CS	2.2.11.6.13			2.6.10.5. 12
PVC-C	Friatec: Friatherm starr	CS	2.2.7.2.5			2.6.6.1.7	
		LS	2.2.7.4.5			2.6.6.2.7	

Intended use of penetrations and reference to relevant section (list not exhaustive, other uses of pipes may be possible)				see section (Annex 2)			
Application	Penetration material	Manufacturer, product (samples)	Insulation	Flexible & rigid wall ≥ 100 mm	Flexible & rigid wall ≥ 135 mm	Rigid wall ≥ 150 mm	Rigid floor ≥ 150 mm
Chilled water pipes	Copper		CS	2.2.5.1.2 2.2.5.2.3	2.3.1.1.2 2.3.1.2.3	2.4.3.2 2.5.3.3	2.6.4.1.2 2.6.4.2.3 2.6.4.3
	Steel, Stainless steel		CS	2.2.5.1.1 2.2.5.2.1 2.2.5.2.2	2.3.1.1.1 2.3.1.2.1 2.3.1.2.2	2.4.3.1 2.5.3.1 2.5.3.2	2.6.4.1.1 2.6.4.2.1 2.6.4.2.2 2.6.4.3
	PE	EN ISO 15494, DIN 8074/8075		2.2.6.3 2.2.8.2 2.2.9.3	2.3.2.2		2.6.5.2 2.6.7.2 2.6.8.2.2
	PE-HD 100 RC	Wavin: Wavin TS	CS	2.2.6.5 2.2.7.2.4			2.6.6.1.3
			LS	2.2.7.4.4			2.6.6.2.3
	Multi-layer	GF: Coolfit		2.2.6.8			2.6.5.9
	PP	Aquatherm: Climatherm Aquatherm: Fusiotherm	CS	2.2.7.2.2 2.2.7.2.3			2.6.6.1.1 2.6.6.1.2 2.6.6.1.5
LS			2.2.7.4.2 2.2.7.4.3			2.6.6.2.1 2.6.6.2.2 2.6.6.2.5	

Intended use of penetrations and reference to relevant section (list not exhaustive, other uses of pipes may be possible)				see section (Annex 2)			
Application	Penetration material	Manufacturer, product (samples)	Insulation	Flexible & rigid wall ≥ 100 mm	Flexible & rigid wall ≥ 135 mm	Rigid wall ≥ 150 mm	Rigid floor ≥ 150 mm
Waste water pipes Storm water / Roof drainage pipes	Cast iron, SML			2.2.5.1.1 2.2.5.2.1	2.3.1.1.1 2.3.1.2.1	2.4.3.1 2.5.3.1	2.6.4.1.1 2.6.4.2.1 2.6.4.3
	PE	EN1519		2.2.6.2 2.2.7.1 2.2.7.3 2.2.8.3 2.2.9.1			2.6.5.3 2.6.8.2.1
	PE-S2	Geberit: Silent -db20		2.2.6.4 2.2.9.6			2.6.5.4 2.6.5.7 2.6.8.2.3
	PP	Rehau "Raupiano Plus", Magnaplast „Skolan-dB“, Wavin "Wavin AS", "Wavin SiTech" KeKelit "Phonex AS", Poloplast "Polokal NG", Polokal 3S" Geberit "Siltent PP", Coes "Blue Power", "PhoNoFire", Valsir "Triplus", "Silere", Pipelife "Master 3"		2.2.6.6 2.2.9.4 2.2.9.5			2.6.5.6 2.6.8.3

Intended use of penetrations and reference to relevant section (list not exhaustive, other uses of pipes may be possible)				see section (Annex 2)			
Application	Penetration material	Manufacturer, product (samples)	Insulation	Flexible & rigid wall ≥ 100 mm	Flexible & rigid wall ≥ 135 mm	Rigid wall ≥ 150 mm	Rigid floor ≥ 150 mm
Waste water pipes Storm water / Roof drainage pipes (continue)	PVC-U	EN ISO 1452		2.2.6.1 2.2.8.1 2.2.9.1	2.3.2.1	2.4.4	2.6.5.1 2.6.5.2 2.6.7.1 2.6.8.1
	PP	EN 1455-1, EN15874		2.2.6.6, 2.2.6.7			

Intended use of penetrations and reference to relevant section (list not exhaustive, other uses of pipes may be possible)				see section (Annex 2)			
Application	Penetration material	Manufacturer, product (samples)	Insulation	Flexible & rigid wall ≥ 100 mm	Flexible & rigid wall ≥ 135 mm	Rigid wall ≥ 150 mm	Rigid floor ≥ 150 mm
Pneumatic pipes	Steel			2.2.4		2.4.2 2.5.2	2.6.3
	PVC-U	EN ISO 1452		2.2.6.1 2.2.8.1 2.2.9.1	2.3.2.1	2.4.4	2.6.5.1 2.6.5.2 2.6.7.1 2.6.8.1

Intended use of penetrations and reference to relevant section (list not exhaustive, other uses of pipes may be possible)				see section (Annex 2)				
Application	Penetration material	Manufacturer, product (samples)	Insulation	Flexible & rigid wall ≥ 100 mm	Flexible & rigid wall ≥ 135 mm	Rigid wall ≥ 150 mm	Rigid floor ≥ 150 mm	
Industry pipes	Copper		CS	2.2.5.1.2 2.2.5.2.3	2.3.1.1.2 2.3.1.2.3	2.4.3.2 2.5.3.3	2.6.4.1.2 2.6.4.2.3 2.6.4.3	
			CI					
			LS					
			LI					
	Steel, stainless steel			CS	2.2.5.1.1 2.2.5.2.1 2.2.5.2.2	2.3.1.1.1 2.3.1.2.1 2.3.1.2.2	2.4.3.1 2.5.3.1 2.5.3.2	2.6.4.1.1 2.6.4.2.1 2.6.4.2.2 2.6.4.3
				CI				
				LS				
				LI				
	Al-Composite pipes	Geberit: Mepla Rehau: Rautitan stabil KeKelit: Kelox KM 110		CS	2.2.10.1 2.2.11.1 2.2.12.1			2.6.9 2.6.10
				LS	2.2.11.2 2.2.12.2			
	PE	EN ISO 15494, DIN 8074/8075			2.2.6.3 2.2.8.2 2.2.9.3	2.3.2.2		2.6.5.2 2.6.7.2 2.6.8.2.2
	PE-HD 100 RC	Wavin: Wavin TS			2.2.6.5 2.2.7.2.4 2.2.7.4.4			2.6.5.5 2.6.6.1.3 2.6.6.2.3

Intended use of penetrations and reference to relevant section (list not exhaustive, other uses of pipes may be possible)				see section (Annex 2)			
Application	Penetration material	Manufacturer, product (samples)	Insulation	Flexible & rigid wall ≥ 100 mm	Flexible & rigid wall ≥ 135 mm	Rigid wall ≥ 150 mm	Rigid floor ≥ 150 mm
Industry pipes (cont.)	PE-S2	Geberit: Silent -db20		2.2.6.4 2.2.9.6			2.6.5.4 2.6.5.7 2.6.8.2.3
	PP	Rehau "Raupiano Plus", Magnaplast „Skolan-dB", Wavin "Wavin AS", "Wavin SiTech" KeKelit "Phonex AS", Poloplast "Polokal NG, Polokal 3S" Geberit "Siltent PP", Coes "Blue Power", "PhoNoFire", Valsir "Triplus", "Silere", Pipelife "Master 3"		2.2.6.6 2.2.9.4 2.2.9.5			2.6.5.6 2.6.8.3
	PP fibre compound	EN ISO 15874 Aquatherm: Fusiotherm, Aquatherm: Climatherm Aquatherm: Firestop +GF+: Progef standard pipe +GF+: Dekaprop Industry pipe		2.2.6.7 2.2.7.2.2 2.2.7.2.3 2.2.7.4.2 2.2.7.4.3			2.6.5.7 2.6.5.8 2.6.6.1.1 2.6.6.1.2 2.6.6.1.5 2.6.6.1.6 2.6.6.2.1 2.6.6.2.2 2.6.6.2.5 2.6.6.2.6
	PVC-U	EN ISO 15494, DIN 8074/8075			2.3.2.1	2.4.4	
	PVC-C	Aquatherm: Friatherm starr		2.2.7.2.5 2.2.7.4.5			2.6.6.1.7 2.6.6.2.7

Intended use of penetrations and reference to relevant section (list not exhaustive, other uses of pipes may be possible)				see section (Annex 2)			
Application	Penetration material	Manufacturer, product (samples)	Insulation	Flexible & rigid wall ≥ 100 mm	Flexible & rigid wall ≥ 135 mm	Rigid wall ≥ 150 mm	Rigid floor ≥ 150 mm
Industry pipes (cont.)	Pre-isolated multi-layer	GF: Coolfit		2.2.6.8			2.6.5.9
	Special pellet pipe	CASTAN: Sciroppo AS Erich Kuhn: PVC NW51 Haberkorn: PVC Saug-/Druckschl. Heizmann: Noviatox NW51 Rehau: RAUSPIRAFLEX		2.2.6.9			2.6.5.10

2.1.2 Additional protection for cable/small conduit penetrations

Depending on the required fire resistance additional protection (AP) may be required (for details see Annex 2):

- AP1:** cables / small conduits coated with Hilti Firestop Coating CFS-CT over a length of the cables / small conduits of 150 mm from the surface of the seal, thickness 0.7 mm.
- AP2:** cables / small conduits coated with Hilti Firestop Coating CFS-CT over a length of the cables / small conduits of 200 mm from the surface of the seal, thickness 1 mm.
- AP3:** cables / small conduits coated with Hilti Firestop Coating CFS-CT over a length of the cables / small conduits of 200 mm from the surface of the seal, thickness 2 mm.
- AP4:** Mineral wool mat according to Table 2, wrapped around cables /cable support (trays, ladders), Al-faced side outside, fixed with wire, width (length along the cables/small conduits) 200 mm, thickness 20 mm.
- AP5:** Mineral wool mat according to Table 2, wrapped around cables /cable support (trays, ladders), Al-faced side outside, fixed with wire, width (length along the cables/small conduits) 200 mm, thickness 30 mm.

2.1.3 Additional components for composite and plastic pipe penetrations

In some cases of metal pipes or composite pipes insulated with combustible insulation (reaction to fire class B to E according EN 13501-1) a Hilti Firestop Bandage CFS-B (see ETA-10/0212) is wrapped around the pipe insulation on each side of the seal (with floor applications in some cases only on bottom side). The bandage is positioned with half of its width (62.5 mm) within the seal (central marking line at the surface of the seal) and fixed with wire. For necessary number of layers of the bandage see Annex 2.

In some cases an additional protection (AP) over the bandage is required. Two types of additional protection as described below may be used - for details see Annex 2:

- AP6:** Armaflex AF pipe insulation wrapped around the bandage/pipe insulation, fixed with wire, length along the pipe 300 mm, thickness 19 mm or 32 mm.
- AP7:** Mineral wool mat according to Table 2, wrapped around the bandage/pipe insulation, fixed with wire, length along the pipe 300 mm, thickness 20 mm.

In some cases (see Annex 2) Hilti Firestop Wrap CFS-W EL / SG (see ETA-10/0405) or Hilti Firestop Wrap CFS-W P is wrapped around the pipe on each side of the seal (with floor applications on bottom side only) and positioned within the annular gap so that the outer edge of the wrap is flush with the surface of the construction element. For necessary number of layers of the wrap and further details see Annex 2.

In some cases (see Annex 2) Hilti Firestop Collar CFS-C (see ETA-10/0403) , Hilti Firestop Collar CFS-C P (see ETA-10/0404) or Hilti Firestop Collar Endless CFS-C EL is placed around the pipe on each side of the seal (with floor applications on bottom side only) and fixed with threaded rods and nuts (see Annex 1.2.7). For required type of collar and further details see Annex 2.

In some cases for applications in 150 mm floors (see Annex 2) an additional internal mineral wool board is required:

AP9: Mineral wool board according to table 1 installed around the pipe in the air gap between the two layers of the Hilti Firestop Double Board Seal. Distance on all sides of the pipe 100 mm, depth 50 mm (height of the air gap).

2.1.4 Additional components for metal pipe penetrations

AP8: Mineral wool mat according to Table 2 in 1.2.11 wrapped around the pipe insulation, fixed with wire, length along the pipe 250 mm, thickness 40 mm. Applicable for isolated metal pipes too.

For details of the seal construction see Annex 2.

2.1.5 Additional components for cable penetrations

In some cases (see Annex 2) Hilti Firestop Sleeve CFS-SL M (see ETA-11/0153) is centered in the wall and fixed by means of two flanges delivered together with the sleeve.

AP10: Mineral wool acc. Table 2 wrapped around the Hilti Firestop Sleeve CFS-SL M on both sides of the seal over the total visible length of the sleeve, thickness 30 mm.

AP11: Duct tape (adhesive polyethylene based tape-width:50mm-length 200mm – number of layers:1)

AP12: Armaflex adhesive tape- thickness 3mm – position: over a length of 50mm wrapped around the pipe insulation

For details of the seal construction see Annex 2.

2.1.6 Non-regulated PP-pipes

There is a bigger group of non-regulated polypropylene-pipes, mineral reinforced, mainly used in waste water application. Most of them consist of a three-layer set-up. Those pipes have not specified according a common pipe standard. The following pipes are considered equal in their fire properties presupposed:

1. pipe diameter and pipe wall thickness are covered by the field of application shown within relevant chapters within this ETA
2. identical pipe-end configuration
3. identical used Hilti penetration seals
4. identical installation details (for instance: gap size, gap filling, basement thickness and density, first support,...)

- Rehau Raupiano
- Poloplast Polokal NG
- Wavin Sitech
- Geberit Silent PP
- Coes Blue Power
- Coes PhoNo Fire
- Valsir Triplus
- Pipelife Master 3
- Marley Silent
- Poloplast Polokal 3S
- Poloplast Polokal XS
- Ostendorf Skolan dB
- Geberit Silent Pro
- Valsir Silere
- Kekelit PhonEx AS
- Wavin AS
- Silenta Premium
- Wavin Sitech +
- Conel Drain Hausabflußrohr
- Uponor S&W Decibel

2.2 Flexible walls according to 2.1 a) and rigid walls according to 2.1 b), minimum thickness 100 mm

Penetration seal:

Two 50 mm Hilti Firestop Boards CFS-CT B 1S¹ (A₁) or mineral wool boards according to Table 1 coated with Hilti Firestop Coating CFS-CT (A₁), dry thickness of coating 0.7 mm on the outer side², all cut edges of boards sealed with Hilti Firestop Acrylic Sealant CFS-S ACR, remaining gaps around cables / cable supports (trays, ladders etc.) and other services filled with Hilti Firestop Acrylic Sealant CFS-S ACR.

The boards have to be positioned flush to the surface of the building element on each side of the wall.

Maximum distance for 1st service support: 250 mm.

Maximum seal size: 1200 x 1200 mm (width x height) for classification EI 120, 1200 x 2000 mm (width x height) for classification EI 90.

Minimum distances in mm (see illustration below):

s ₁ = 0	(distance between cables/cable supports and seal edge)
s ₂ = 0	(distance between cable supports)
s ₃ = 0	(distance between cables and upper seal edge)
s ₄ = 0	(distance between cable supports and bottom seal edge)
s ₅ = 50	(distance between cables and cable support above)
s ₆ = 3	(distance between metal pipes and seal edge)
s ₇ = 3	(distance between metal pipes and upper seal edge)
s ₈ = 0	(distance between metal pipes)
s ₉ = 17	(distance between plastic pipes/pipe closure devices and seal edge)
s ₁₀ = 17	(distance between plastic pipes/pipe closure devices and upper seal edge)
s ₁₁ = 0	(distance between plastic pipes/pipe closure devices)
s ₁₂ = 30	(distance between metal pipes and plastic pipes/pipe closure devices)
s ₁₃ = 3	(distance between cables/cable supports and metal pipes)
s ₁₄ = 40	(distance between cables/cable supports and plastic pipes/pipe closure devices)

¹ Hilti Firestop Boards CFS-CT B 2S (coated on both faces) may also be used

² The board may also be coated on both faces

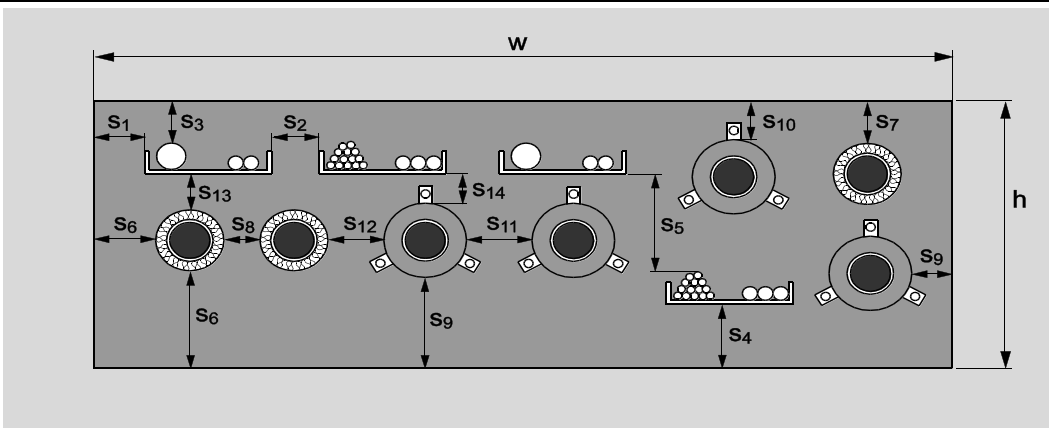

Penetrating services :(single, multiple or mixed)

2.2.1 Blank seal (no services) *

Construction details (for symbols and abbreviations see Annex 4):

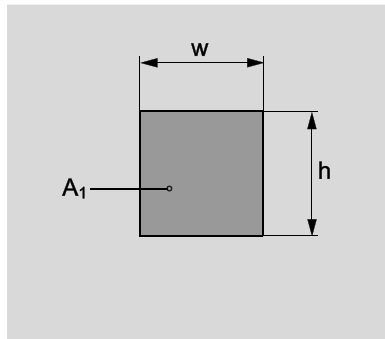
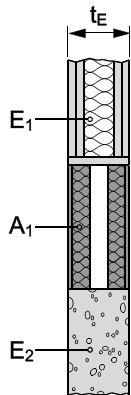

Classification

* If services are added later on in a blank seal only the services listed in the tables below may be added that fulfil the required classification

Maximum size 1200mm x 1200 mm (width **w** x height **h**)

EI 120

2.2.2 Cables

Construction details (for symbols and abbreviations see Annex 4):

Additional protection AP₃, AP₄ or AP₅ according to 1.2. may be used. AP₄ and AP₅ are illustrated below.

AP₃: cables/small conduits coated with Hilti Firestop Coating CFS-CT on both sides of the seal over a length of the cables/small conduits of 200 mm from the surface of the seal, thickness 2 mm.

AP₄: Mineral wool mat according to Table 2, wrapped around cables /cable support (trays, ladders) on both sides of the seal, Al-faced side outside, fixed with wire, width (length along the cables/small conduits) 200 mm, thickness 20 mm.

AP₅: Mineral wool mat according to Table 2, wrapped around cables /cable support (trays, ladders) on both sides of the seal, Al-faced side outside, fixed with wire, width (length along the cables/small conduits) 200 mm, thickness 30 mm.

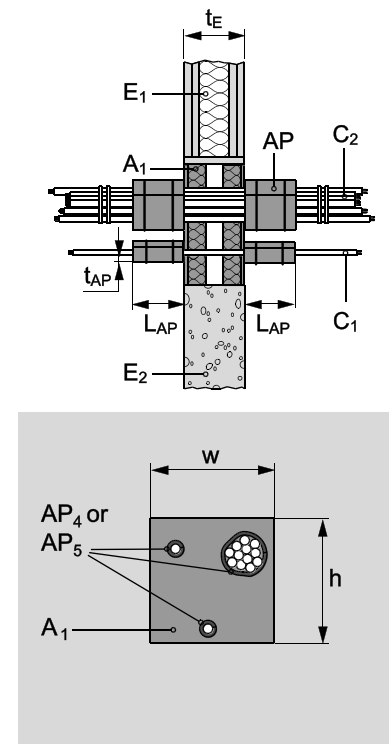
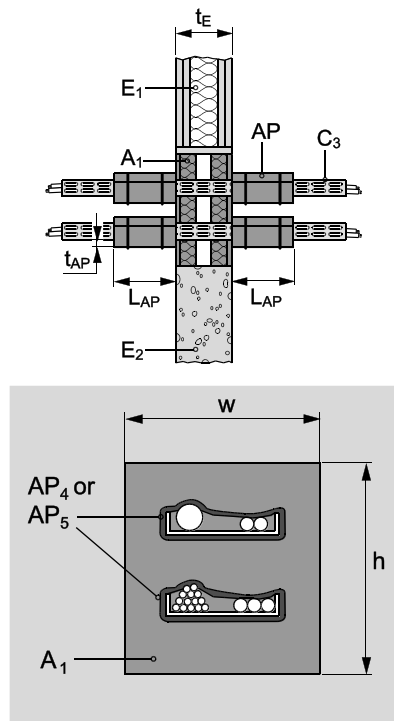

Additional protection according to 1.2:	Classification		
	AP ₃	AP ₄	AP ₅
All sheathed cable types currently and commonly used in building practice in Europe (e.g. power, control, signal, telecommunication, data, optical fibre cables, with or without cable supports, with a diameter of:			
Maximum Ø 21 mm	EI 90	EI 120	EI 120
21 ≤ Ø ≤ 50 mm	EI 90	EI 90	EI 120
50 ≤ Ø ≤ 80 mm	EI 90	EI 90	EI 120
Non-sheathed cables (wires) currently and commonly used in building practice in Europe, with or without cable supports, with a diameter of:			
Maximum Ø 17 mm	EI 60	EI 120	EI 120
Maximum Ø 24 mm	EI 60	EI 120	EI 120
Tied cable bundle, maximum diameter of single cable 21 mm, with or without cable supports			
Maximum Ø 100 mm	EI 90	EI 120	EI 120

2.2.3 Cables with Hilti Firestop Sleeve CFS-SL M and Hilti Firestop Sleeve CFS-SL GA

Construction details

(for symbols and abbreviations see Annex 4):

Hilti Firestop Sleeve CFS-SL M or CFS-SL GA (A₅) centered in the wall and fixed by means of two flanges delivered together with the sleeve.

For Hilti Firestop Sleeve CFS-SL GA (A₅);

Use Hilti Firestop Acrylic Sealant CFS-S ACR to seal the gap between the metallic sleeve and the board CFS-CT perimeter seal edge.

Install some CFS-S ACR onto the CFS-CT surface around the installed Sleeve before screwing the flanges tightly to board surface.

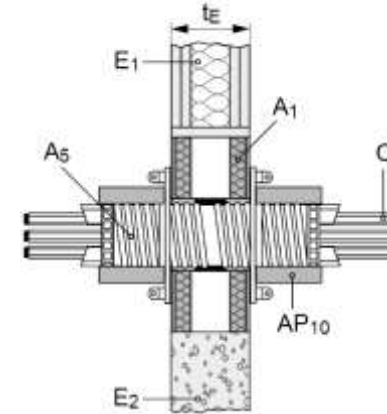

AP₁₀: Mineral wool acc. Table 2 wrapped around the Hilti Firestop Sleeve CFS-SL M on both sides of the seal over the total visible length of the sleeve, thickness 30 mm

Classification

All sheathed cable types currently and commonly used in building practice in Europe (e.g. power, control, signal, telecommunication, data, optical fibre cables) with a maximum Diameter: $\varnothing \leq 21$ mm

EI 120

2.2.4 Small conduits and tubes

Construction details: see 2.2.2

Classification

$\varnothing \leq 16$ mm, wall thickness ≥ 1 mm, arranged linear, with or without cables, with or without cable supports

Additional protection according to 1.2

AP₃

AP₄

AP₅

Plastic conduits and tubes	EI 120-U/C	EI 120-U/C	EI 120-U/U
Steel conduits and tubes	EI 90-C/U	EI 120-C/U	EI 120-U/U

2.2.4.1 3 plastic conduits in 1 Hilti Firestop Collar CFS-C P – U/U

With and without cables

Construction details:

Hilti Firestop Collars CFS-C P (A_3) are installed on both sides of the seal, fixed together by threaded rods, washers and nuts as specified in Annex 1.2.

(for symbols and abbreviations see Annex 4):

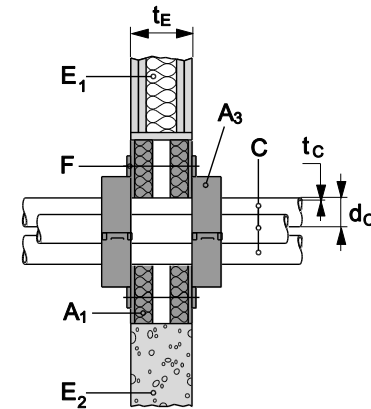

Pipe diameter (d_c) [mm]	Pipe wall thickness t_c [mm]	Pipe material / standard	Collar size (A_3)	No. of hooks	Classification
16	1.0	PVC,	CFS-C P 63/2"	3	EI 120-U/C
25	1.5	PVC			
32	2	Polyolefin			

2.2.5 Metal pipes

2.2.5.1 Metal pipes with mineral wool insulation according to Table 3

Construction details (for symbols and abbreviations see Annex 4):

For higher classification additional protection AP₈ according to 1.2 may be used.

AP₈: Mineral wool mat according to Table 2, wrapped around the pipe insulation on both sides of the seal, fixed with wire, length along the pipe 250 mm, thickness 40 mm.

Continued insulation, interrupted (CI)

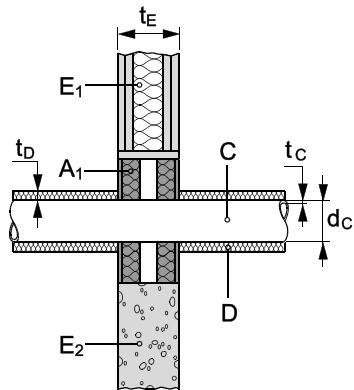

Continued insulation, sustained (CS)

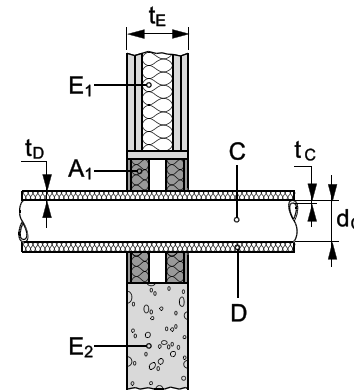

Local insulation, interrupted (LI)

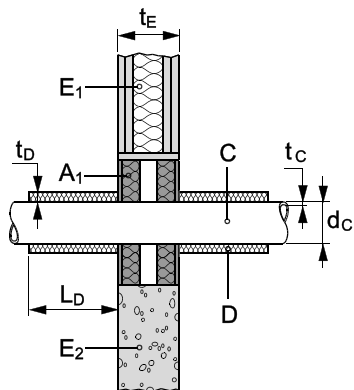

Local insulation, sustained (LS)

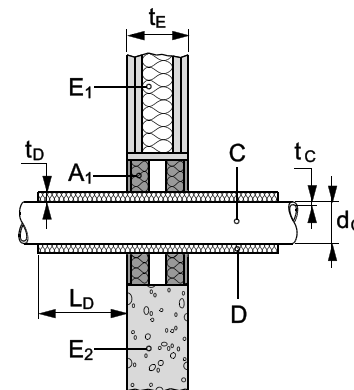

2.2.5.1.1 Steel pipes with mineral wool insulation according to Table 3				
Steel pipes (C) with continued insulation (D) – sustained – C/U				
Pipe diameter (d _c) [mm]	Pipe wall thickness (t _c) [mm]	Insulation thickness (t _D) [mm]	Classification	
48.3	1.6 - 14.2 ³	≥ 20	EI 90-C/U	
Steel pipes (C) with continued insulation (D) – sustained – U/C				
Pipe diameter (d _c) [mm]	Pipe wall thickness (t _c) [mm]	Insulation thickness (t _D) [mm]	Classification	
Additional protection according 1.2			-	AP ₈
114.3	2.0 - 14.2	≥ 30	EI 60-U/C	-
114.3	2.0 - 14.2	≥ 40	EI 120-U/C	-
114.3 – 159.0	2.0/2.6 – 14.2 ⁴	≥ 40	EI 60-U/C	-
159.0	2.6 - 14.2	≥ 40	EI 60-U/C	EI 120-U/C
159.0 - 323.9	2.6/4.0 – 14.2 ⁵	≥ 40	EI 60-U/C	EI 90-U/C

3 14.2 mm is the maximum value covered by the rules in EN 1366-3. This value may be limited by the particular pipe dimensions available in practice.

4 Interpolation of minimum wall thickness between 2.0 mm for diameter 114.3 mm and 2.6 mm for diameter 159.0 mm for pipe diameters in between.

5 Interpolation of minimum wall thickness between 2.6 mm for diameter 159 mm and 4.0 mm for diameter 323.9 mm for pipe diameters in between.

Steel pipes (C) with continued insulation (D) – interrupted – C/U					
Pipe diameter (d _c) [mm]	Pipe wall thickness (t _c) [mm]	Insulation thickness (t _D) [mm]		Classification	
26.9	1.4 – 14.2 ¹⁰	≥ 40		EI 120-C/U	
34.0 – 48.3	4.0 - 14.2 ¹⁰	≥ 20		EI 120-C/U	
48.3	1.6 - 14.2 ¹⁰	≥ 20		EI 120-C/U	
34.0 - 114.3	3.6 - 14.2 ¹⁰	≥ 30		EI 120-C/U	
Steel pipes (C) with continued insulation (D) – interrupted – U/C					
Pipe diameter (d _c) [mm]	Pipe wall thickness (t _c) [mm]	Insulation thickness (t _D) [mm]		Classification	
114.3	2.0 - 14.2 ¹⁰	≥ 30		EI 120-U/C	
114.3 – 159.0	2.0/2.6 – 14.2 ¹¹	≥ 40		EI 120-U/C	
159.0 - 323.9	2.6/4.0 – 14.2 ¹²	≥ 40		EI 60-U/C	
Steel pipes (C) with local insulation (D) – sustained – C/U					
Pipe		Insulation		Classification	
diameter (d _c) [mm]	wall thickness (t _c) [mm]	thickness (t _D) [mm]	length (L _D) [mm]		
48.3	1.6 - 14.2 ¹⁰	20	≥ 450	EI 90-C/U	
Steel pipes (C) with local insulation (D) – sustained – U/C					
Pipe		Insulation		Classification	
diameter (d _c) [mm]	wall thickness (t _c) [mm]	thickness (t _D) [mm]	length (L _D) [mm]		
Additional protection according to 1.2:				-	AP ₈
114.3	2.0 - 14.2	30 - 40	≥ 500	EI 60-U/C	-
114.3 – 159.0	2.0/2.6 – 14.2 ¹¹	40	≥ 500	EI 45-U/C	-
114.3	2.0 - 14.2	40	≥ 1000	EI 120-U/C	-
159.0	2.6 - 14.2	40	≥ 1000	EI 60- U/C	EI 90-U/C
114.3 – 159.0	2.0/2.6 – 14.2 ¹¹	40	≥ 1000	EI 60- U/C	-
159.0 - 323.9	2.6/4.0 – 14.2 ¹²	40	≥ 1000	EI30-U/C	-

Steel pipes (C) with local insulation (D) – interrupted – C/U				
Pipe		Insulation		Classification
diameter (d _c) [mm]	wall thickness (t _c) [mm]	thickness (t _D) [mm]	length (L _D) [mm]	
26.9	1.4 – 14.2 ¹⁰	40	≥ 500	EI 120-C/U
34.0 – 48.3	4.0 - 14.2 ¹⁰	20	≥ 500	EI 120-C/U
48.3	1.6 - 14.2 ¹⁰	20	≥ 500	EI 120-C/U
114.3	3.6 - 14.2	30	≥ 500	EI 120-C/U
Steel pipes (C) with local insulation (D) – interrupted – U/C				
Pipe		Insulation		Classification
diameter (d _c) [mm]	wall thickness (t _c) [mm]	thickness (t _D) [mm]	length (L _D) [mm]	
114.3	2.0 – 14.2	30 - 40	≥ 500	EI 60-U/C
114.3 – 159.0	2.0/2.6 – 14.2 ¹¹	40	≥ 500	EI 45-U/C
114.3	2.0 – 14.2	40	≥ 1000	EI 120-U/C
114.3 – 159.0	2.0/2.6 – 14.2 ¹¹	40	≥ 1000	EI 90-U/C
159.0 – 323.9	2.6/4.0 – 14.2 ¹²	40	≥ 1000	EI 30-U/C

2.2.5.1.2 Copper pipes with mineral wool insulation according to Table 3				
Copper pipes (C) with continued insulation (D) – sustained – C/U				
Pipe diameter (d _c) [mm]	Pipe wall thickness (t _c) [mm]	Insulation thickness (t _b) [mm]	Classification	
28	1.0 – 14.2 ¹⁰	≥ 20	EI 120-C/U	
28 - 42	1.0/1.5 - 14.2 ^{10, 6}	≥ 20	EI 60-C/U	
28 - 42	1.0/1.5 - 14.2 ^{10, 13}	≥ 40	EI 120-C/U	
Copper pipes (C) with continued insulation (D) – sustained – U/C				
Pipe diameter (d _c) [mm]	Pipe wall thickness (t _c) [mm]	Insulation thickness (t _b) [mm]	Classification	
Additional protection according 1.2			-	AP ₈
10 - 40	1.0/1.5 - 14.2 ^{10, 7}	≥ 20	EI 120-U/C	-
40 – 88.9	1.5/2.0 - 14.2 ^{10, 8}	≥ 40	EI 90-U/C	EI 120-U/C
			-	
Copper pipes (C) with continued insulation (D) – interrupted – C/U				
Pipe diameter (d _c) [mm]	Pipe wall thickness (t _c) [mm]	Insulation thickness (t _b) [mm]	Classification	
28	1.0 – 14.2 ¹⁰	≥ 20	EI 120-C/U	
28 - 42	1.0/1.5 - 14.2 ^{10, 13}	≥ 40	EI 120-C/U	
Copper pipes (C) with continued insulation (D) – interrupted – U/C				
Pipe diameter (d _c) [mm]	Pipe wall thickness (t _c) [mm]	Insulation thickness (t _b) [mm]	Classification	
10 - 40	1.0/1.5 - 14.2 ^{10, 14}	≥ 20	EI 120-U/C	
40 – 88.9	1.5/2.0 - 14.2 ^{10, 15}	≥ 40	EI 120-U/C	

6 Interpolation of minimum wall thickness between 1.0 mm for diameter 28 mm and 1.5 mm for diameter 42 mm for pipe diameters in between.

7 Interpolation of minimum wall thickness between 1.0 mm for diameter 10 mm and 1.5 mm for diameter 40 mm for pipe diameters in between.

8 Interpolation of minimum wall thickness between 1.5 mm for diameter 40 mm and 2.0 mm for diameter 88.9 mm for pipe diameters in between.

Copper pipes (C) with local insulation (D) – sustained – C/U				
Pipe		Insulation		Classification
diameter (d _c) [mm]	wall thickness (t _c) [mm]	thickness (t _D) [mm]	length (L _D) [mm]	
28	1.0 – 14.2 ¹⁰	20	≥ 450	EI 120-C/U
42	1.5 – 14.2 ¹⁰	20	≥ 450	EI 60-C/U
42	1.5 – 14.2 ¹⁰	40	≥ 800	EI 120-C/U
Copper pipes (C) with local insulation (D) – sustained – U/C				
Pipe		Insulation		Classification
diameter (d _c) [mm]	wall thickness (t _c) [mm]	thickness (t _D) [mm]	length (L _D) [mm]	
10	1.0 – 14.2 ¹⁰	20 – 30	≥ 500	EI 120-U/C
10 - 40	1.0/1.5 - 14.2 ^{10, 14}	20	≥ 500	EI 120-U/C
40 – 88.9	1.5/2.0 - 14.2 ^{10, 15}	40	≥ 1000	EI 90-U/C
Copper pipes (C) with local insulation (D) – interrupted – C/U				
Pipe		Insulation		Classification
diameter (d _c) [mm]	wall thickness (t _c) [mm]	thickness (t _D) [mm]	length (L _D) [mm]	
28 - 42	1.0/1.5 - 14.2 ^{10, 13}	20	≥ 500	EI 120-C/U
42	1.5 – 14.2 ¹⁰	40	≥ 800	EI 120-C/U
Copper pipes (C) with local insulation (D) – interrupted – U/C				
Pipe		Insulation		Classification
diameter (d _c) [mm]	wall thickness (t _c) [mm]	thickness (t _D) [mm]	length (L _D) [mm]	
10	1.0 – 14.2 ¹⁰	20 - 30	≥ 500	EI 120-U/C
10 - 40	1.0/1.5 - 14.2 ^{10, 14}	20	≥ 500	EI 120-U/C
40 – 88.9	1.5/2.0 - 14.2 ^{10, 15}	40	≥ 1000	EI 90-U/C
The field of application given above for copper pipes is also valid for other metal pipes with lower heat conductivity than copper and a melting point of minimum 1100°C, e.g. unalloyed steel, low alloyed steel, cast iron, stainless steels, Ni alloys (NiCu, NiCr and NiMo alloys) and Ni.				

2.2.5.2.1 Steel pipes with foamed elastomeric insulation according Table 4 and Hilti Firestop Bandage CFS-B				
Steel pipes (C) with continued insulation (D) – sustained – C/U				
Pipe diameter (d _c) [mm]	Pipe wall thickness (t _c) [mm]	Insulation thickness (t _D) [mm]		Classification
60.3	3.6 - 14.2 ¹⁰	21.5 - 39		EI 90-C/U
60.3 - 114.3	3.6 - 14.2 ¹⁰	21.5 - 39		EI 60-C/U
114.3	3.6 - 14.2	43		EI 90-C/U
Steel pipes (C) with continued insulation (D) – sustained – U/C				
Pipe diameter (d _c) [mm]	Pipe wall thickness (t _c) [mm]	Insulation thickness (t _D) [mm]		Classification
114.3	2.0 – 14.2	9 - 20		EI 90-U/C
114.3 – 159.0	2.0/2.6 – 14.2 ¹¹	9 - 10		EI 60-U/C
159.0	2.6 – 14.2	10 - 45		EI 60-U/C
Steel pipes (C) with local insulation (D) – sustained – C/U				
Pipe		Insulation		Classification
diameter (d _c) [mm]	wall thickness (t _c) [mm]	thickness (t _D) [mm]	length (L _D) [mm]	
60.3	3.6 - 14.2 ¹⁰	21.5 - 39	≥ 500	EI 90-C/U
60.3 - 114.3	3.6 - 14.2 ¹⁰	21.5 - 39	≥ 500	EI 60-C/U
114.3	3.6 - 14.2	43	≥ 500	EI 90-C/U
The field of application given above for steel pipes is also valid for other metal pipes with lower heat conductivity than unalloyed steel and a melting point of minimum 1050°C, e.g. low alloyed steel, cast iron, stainless steels, Ni alloys (NiCu, NiCr and NiMo alloys)				

2.2.5.2.2 Stainless steel pipes with foamed elastomeric insulation according Table 4 and Hilti Firestop Bandage CFS-B				
Stainless steel pipes (C) with continued insulation (D) – sustained – C/U				
Pipe diameter (d _c) [mm]	Pipe wall thickness (t _c) [mm]	Insulation thickness (t _D) [mm]	Classification	
60.3	2.0 - 14.2 ¹⁰	21.5 - 39	EI 120-C/U	
Stainless steel pipes (C) with local insulation (D) – sustained – C/U				
Pipe		Insulation		Classification
diameter (d _c) [mm]	wall thickness (t _c) [mm]	thickness (t _D) [mm]	length (L _D) [mm]	
60.3	2.0 - 14.2 ¹⁰	21.5 - 39	≥ 500	EI 120-C/U

2.2.5.2.3 Copper pipes with foamed elastomeric insulation according Table 4 and Hilti Firestop Bandage CFS-B				
Copper pipes (C) with continued insulation (D) – sustained – C/U				
Pipe diameter (d _c) [mm]	Pipe wall thickness (t _c) [mm]	Insulation thickness (t _D) [mm]	Classification	
28	1.0 - 14.2 ¹⁰	19 - 35	EI 120-C/U	
Copper pipes (C) with continued insulation (D) – sustained – U/C				
Pipe diameter (d _c) [mm]	Pipe wall thickness (t _c) [mm]	Insulation thickness (t _D) [mm]	Classification	
10	1.0 – 14.2 ¹⁰	7.5 – 40.5	EI 120-U/C	
10 - 40	1.0/1.5 – 14.2 ^{10, 14}	7.5 - 9	EI 90-U/C	
40 – 88.9	1.5/2.0 – 14.2 ¹⁵	9 – 9.5	EI 45-U/C	
40 – 88.9	1.5/2.0 – 14.2 ¹⁵	45.5 – 47.5	EI 120-U/C	
88.9	2.0 – 14.2 ¹⁰	9.5 – 47.5	EI 45-U/C	
88.9	2.0 – 14.2 ¹⁰	15 – 47.5	EI 60-U/C	

Copper pipes (C) with local insulation (D) – sustained – C/U				
Pipe		Insulation		Classification
diameter (d _c) [mm]	wall thickness (t _c) [mm]	thickness (t _D) [mm]	length (L _D) [mm]	
28	1.0 - 14.2 ¹⁰	19 - 35	≥ 500	EI 120-C/U
The field of application given above for copper pipes is also valid for other metal pipes with lower heat conductivity than copper and a melting point of minimum 1100°C, e.g. unalloyed steel, low alloyed steel, cast iron, stainless steels, Ni alloys (NiCu, NiCr and NiMo alloys) and Ni.				

2.2.6 Plastic pipes with Hilti Firestop Collar CFS-C P

Construction details (for symbols and abbreviations see Annex 4):

Hilti Firestop Collars CFS-C P (A_3) are installed on both sides of the seal, fixed together by threaded rods, washers and nuts as specified in Annex 1.2.

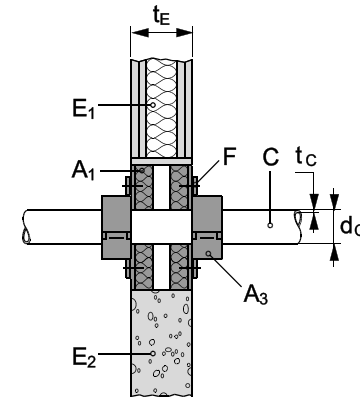

2.2.6.1 PVC-U pipes (C) according to EN ISO 1452-2, EN ISO 15493, DIN 8061/8062 – U/U

Pipe diameter (d_c) [mm]	Pipe wall thickness t_c [mm]	Collar size (A_3)	No. of hooks	Classification
50	2.4 – 5.6	CFS-C P 50/1.5"	2	EI 90-U/U
50	5.6	CFS-C P 50/1.5"	2	EI 120-U/U
63	3.0 – 4.7	CFS-C P 63/2"	2	EI 90-U/U
75	2.2 – 3.6	CFS-C P 75/2.5"	3	EI 90-U/U
75	2.2	CFS-C P 75/2.5"	3	EI 120-U/U
90	2.7 – 4.3	CFS-C P 90/3"	3	EI 90-U/U
110	2.2 – 8.1	CFS-C P 110/4"	4	EI 90-U/U
110	8.1	CFS-C P 110/4"	4	EI 120-U/U
110 - 125	3.7 – 6.0	CFS-C P 125/5"	4	EI 120-U/U
>125 – 160	2.5 – 11.8	CFS-C P 160/6"	6	EI 120-U/U

The results are also valid for PVC-U pipes according EN 1329-1⁹ and EN 1453-1¹⁰ and PVC-C pipes according EN 1566-1.

2.2.6.2 PE pipes (C) according to EN 1519¹¹ - U/U

Pipe diameter (d _c) [mm]	Pipe wall thickness t _c [mm]	Collar size (A ₃)	No. of hooks	Classification
50	3.0	CFS-C P 50/1.5"	2	EI 90-U/U
63	3.0	CFS-C P 63/2"	2	EI 90-U/U
75	3.0	CFS-C P 75/2.5"	3	EI 90-U/U
90	3.5	CFS-C P 90/3"	3	EI 90-U/U
110	4.2	CFS-C P 110/4"	4	EI 90-U/U
110 - 125	4.8	CFS-C P 125/5"	4	EI 120-U/U
>125 – 160	6.2	CFS-C P 160/6"	6	EI 120-U/U

The results are also valid for PE pipes according to EN 12201-2 and EN 12666-1.

2.2.6.3 PE pipes (C) according to EN ISO 15494, DIN 8074/8075 – U/U

Pipe diameter (d _c) [mm]	Pipe wall thickness t _c [mm]	Collar size (A ₃)	No. of hooks	Classification
50	2.9 – 4.6	CFS-C P 50/1.5"	2	EI 90-U/U
63	1.8 – 5.8	CFS-C P 63/2"	2	EI 90-U/U
75	1.9 – 6.8	CFS-C P 75/2.5"	3	EI 90-U/U
90	2.2 – 8.2	CFS-C P 90/3"	3	EI 90-U/U
110	2.7 – 10.0	CFS-C P 110/4"	4	EI 90-U/U
110 – 125	3.1 – 7.1	CFS-C P 125/5"	4	EI 120-U/U
>125 – 160	4.0 – 9.1	CFS-C P 160/6"	6	EI 120-U/U

⁹ In Germany the pipes have additionally to comply with DIN 19531-10

¹⁰ In Germany the pipes have additionally to comply with DIN 19560-10

¹¹ In Germany the pipes have additionally to comply with DIN 19535-10

²² In Germany the pipes have additionally to comply with DIN 19535-10

2.2.6.4 PE-S2 pipes “Geberit Silent-db20”

Manufacturer: Geberit Int.

2.2.6.4.1 PE-S2 pipes “Geberit Silent-db20”– U/U

Pipe diameter (d _c) [mm]	Pipe wall thickness t _c [mm]	Collar size (A ₃)	No. of hooks	Classification
75	3.6	CFS-C P 75/2.5”	3	EI 90-U/U
90	5.5	CFS-C P 90/3”	3	EI 90-U/U
110	6.0	CFS-C P 110/4”	4	EI 90-U/U

2.2.6.4.2 PE-S2 pipes “Geberit Silent-db20”– C/U

Pipe diameter (d _c) [mm]	Pipe wall thickness t _c [mm]	Collar size (A ₃)	No. of hooks	Classification
135	6.0	CFS-C P 160/6”	6	EI 120-C/U
160	7.0	CFS-C P 160/6”	6	EI 120-C/U

2.2.6.5 PE-HD 100 RC pipes “Wavin TS”– U/U

Manufacturer: Wavin Ireland Ltd.

Pipe diameter (d _c) [mm]	Pipe wall thickness t _c [mm]	Collar size (A ₃)	No. of hooks	Classification
50	4.6	CFS-C P 50/1.5”	2	EI 120-U/U
75	6.8	CFS-C P 75/2.5”	3	EI 90-U/U
90	8.2	CFS-C P 90/3”	3	EI 90-U/U
110	10	CFS-C P 110/4”	4	EI 90-U/U

2.2.6.6 Non-regulated PP pipes with Hilti Firestop Collar CFS-C P

For type/manufacture: see 2.1.6

2.2.6.6.1 PP pipes according EN 1451-1 – U/U

Pipe diameter (d _c) [mm]	Pipe wall thickness t _c [mm]	Collar size (A ₃)	No. of hooks	Classification
32	1.8	CFS-C P 50/1.5"	2	EI 90-U/U
50	1.8 – 2.0	CFS-C P 50/1.5"	2	EI 90-U/U
58	4.0	CFS-C P 63/2"	2	EI 90-U/U
70	4.5	CFS-C P 75/2.5"	3	EI 90-U/U
75	1.9 - 2.3	CFS-C P 75/2.5"	3	EI 90-U/U
90	2.8 - 4.5	CFS-C P 90/3"	3	EI 90-U/U
110	2.7 – 5.3	CFS-C P 110/4"	4	EI 90-U/U

2.2.6.6.2 PP pipes according EN 1451-1 – C/U

Pipe diameter (d _c) [mm]	Pipe wall thickness t _c [mm]	Collar size (A ₃)	No. of hooks	Classification
125	3.1 – 5.3	CFS-C P 125/5"	4	EI 120-C/U
135	5.3 – 5.8	CFS-C P 160/6"	6	EI 120-C/U
160	3.9 – 7.5	CFS-C P 160/6"	6	EI 120-C/U

2.2.6.6.3 PP pipes according EN 1451-1 – U/C

Pipe diameter (d _c) [mm]	Pipe wall thickness t _c [mm]	Collar size (A ₃)	No. of hooks	Classification
78	4.5	CFS-C P 75/2.5"	3	EI 90-U/C

2.2.6.7 PP pipes according to EN ISO 15874 and/or DIN 8077/8078 with Hilti Firestop Collar CFS-C P**2.2.6.7.1 PP-H pipes “PROGEF standard pipe” – U/C**

Manufacturer: Georg Fischer

Pipe diameter (d _c) [mm]	Pipe wall thickness t _c [mm]	Collar size (A ₃)	No. of hooks	Classification
50	4.6	CFS-C P 50/1.5”	2	EI 120-U/C
90	8.2	CFS-C P 90/3”	3	EI 90-U/C

2.2.6.7.2 PP-H pipes “PROGEF standard pipe” – U/U

Manufacturer: Georg Fischer

Pipe diameter (d _c) [mm]	Pipe wall thickness t _c [mm]	Collar size (A ₃)	No. of hooks	Classification
50	2.9	CFS-C P 50/1.5”	2	EI 120-U/U
75	6.8	CFS-C P 75/2.5”	3	EI 90-U/U

2.2.6.7.3 PP-R pipes according EN ISO 15874 – U/C

Pipe diameter (d _c) [mm]	Pipe wall thickness t _c [mm]	Collar size (A ₃)	No. of hooks	Classification
50	8.3	CFS-C P 50/1.5”	2	EI 120-U/C
63	10.5	CFS-C P 63/2”	3	EI 120-U/C
75	12.5	CFS-C P 75/2.5”	3	EI 90-U/C
90	15.0	CFS-C P 90/3”	3	EI 90-U/C

2.2.6.7.4 PP-H 100 pipes “Dekaprop Industry pipes” – U/U

Manufacturer: Georg Fischer

Pipe diameter (d _c) [mm]	Pipe wall thickness t _c [mm]	Collar size (A ₃)	No. of hooks	Classification
50	1.8	CFS-C P 50/1.5”	2	EI 120-U/U
110	2.7	CFS-C P 110/4”	4	EI 90-U/U

2.2.6.8 ABS/PUR/PE-HD pipes “Coolfit”– U/C

Manufacturer: +GF+ Georg Fischer Piping Systems.

Pipe diameter (d _c) [mm]	inner pipe diameter [mm]	Collar size (A ₃)	No. of hooks	Classification
90	32	CFS-C P 90/3”	3	EI 90-U/C
110	40 – 50	CFS-C P 110/4”	4	EI 90-U/C

2.2.6.9 Special pipes with Hilti Firestop Collar CFS-C P

2 small plastic pipes in 1 Hilti Firestop Collar CFS-C P – U/U

Construction details:

Hilti Firestop Collars CFS-C P (A₃) are installed on both sides of the seal, fixed together by threaded rods, washers and nuts as specified in Annex 1.2 .

(for symbols and abbreviations see Annex 4)

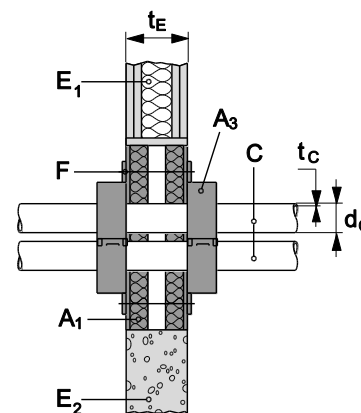

Pipe diameter (d _c) [mm]	Pipe wall thickness t _c [mm]	Pipe material	Pipe standard	Collar size (A ₃)	No. of hooks	Classification
20	1.9 / 2.8	PE	EN ISO 15494, DIN 8074/8075	CFS-C P 50/1.5"	2	EI 120-U/U
20	1.5 / 2.2	PVC-U	EN ISO 15493, DIN 8061/8062	CFS-C P 50/1.5"	2	EI 120-U/U
20	3.4	PP-R	EN ISO 15874, DIN 8077/8078	CFS-C P 50/1.5"	2	EI 120-U/U
20	1.9	PP-H	EN ISO 15874, DIN 8077/8078	CFS-C P 50/1.5"	2	EI 120-U/U

Pipe/hose for wood pellet transport with Hilti Firestop Collar CFS-C P – U/U

Construction details :

Hilti Firestop Collars CFS-C P (A₃) are installed on both sides of the seal, fixed together by threaded rods, washers and nuts as specified in Annex 1.2.

(for symbols and abbreviations see Annex 4)

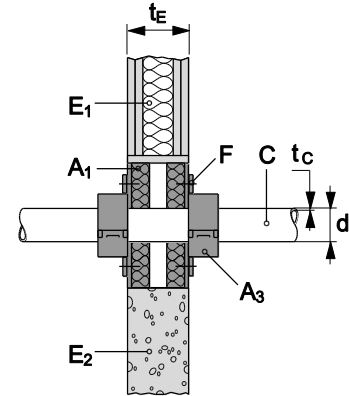

Pipe diameter (d _c) [mm]	Pipe wall thickness t _c [mm]	Pipe material / standard	Collar size (A ₃)	No. of hooks	Classification
59	4.0	Pipe/hose for wood pellet transport, e.g. Pelletschlauch PVC NW51 of Erich Kuhn GmbH, Noviatox NW51 of Heizmann AG, PVC Saug- und Druckschlauch für Holzpellets of Haberkorn GmbH, RAUSPIRAFLEX pellet therm of Rehau AG, Pellet-Absaugschlauch PVC Sciroppo AS of CASTAN GmbH	CFS-C P 63/2"	3	EI 120-U/C

2.2.7 Plastic pipes with foamed elastomeric insulation according to Table 4 and Hilti Firestop Collar CFS-C P

Construction details (for symbols and abbreviations see Annex 4):

For specification of the foamed elastomeric insulation material to be used see Table 4.

Hilti Firestop Collars CFS-C P (A₃) are installed on both sides of the seal, fixed together by threaded rods, washers and nuts as specified in Annex 1.2.

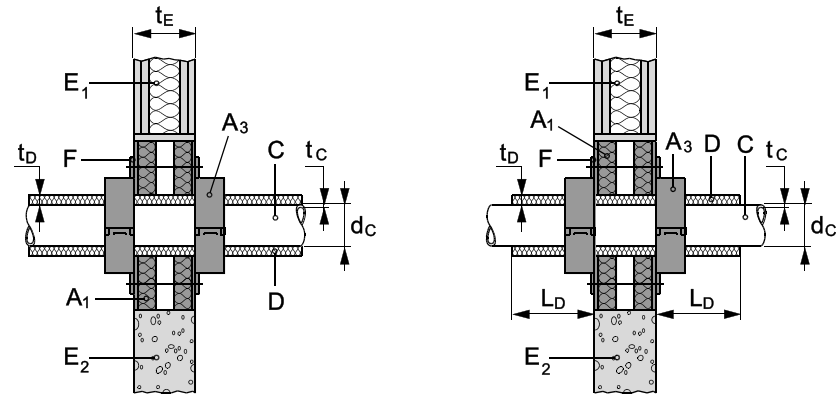

2.2.7.1 PE pipes (C) according to EN 1519¹⁸ (C) with continued insulation (D) – sustained – U/U

Pipe		Insulation	Collar size (A ₃)	No. of hooks	Classification
diameter (d _c) [mm]	wall thickness (t _c) [mm]	thickness (t _D) [mm]			
110	4.2	25	CFS-C P 160/6"	4	EI 90-U/U

The results are also valid for PE pipes according to EN 12201-2 and EN 12666-1.

2.2.7.2 Special plastic Pipes (C) with continued insulation (D) – sustained – U/C

2.2.7.2.1 PE-X pipes according EN ISO 15875

Pipe		Insulation	Collar size (A ₃)	No. of hooks	Classification
diameter (d _c) [mm]	wall thickness (t _c) [mm]	thickness (t _D) [mm]			
40	5.5	9	CFS-C P 50/1.5"	2	EI 90-U/C
50	6.9	9	CFS-C P 63/2"	2	EI 90-U/C
63	8.6	10	CFS-C P 75/2.5"	3	EI 90-U/C

2.2.7.2.2 PP pipes “Fusiotherm SDR 11” - U/C

Manufacturer: Aquatherm

Pipe		Insulation	Collar size (A ₃)	No. of hooks	Classification
diameter (d _c) [mm]	wall thickness (t _c) [mm]	thickness (t _D) [mm]			
40	3.7	9	CFS-C P 50/1.5”	2	EI 120-U/C
50	4.6	9	CFS-C P 63/2”	2	EI 120-U/C
75	6.8	10	CFS-C P 90/3”	3	EI 120-U/C
110	10.0	10	CFS-C P 125/5”	4	EI 120-U/C

2.2.7.2.3 PP pipes “Fusiotherm Faser SDR 7.4/S3.2” - U/C

Manufacturer: Aquatherm

Pipe		Insulation	Collar size (A ₃)	No. of hooks	Classification
diameter (d _c) [mm]	wall thickness (t _c) [mm]	thickness (t _D) [mm]			
40	5.5	9	CFS-C P 50/1.5”	2	EI 120-U/C
50	6.9	9	CFS-C P 63/2”	2	EI 120-U/C
75	10.3	10	CFS-C P 90/3”	3	EI 120-U/C
110	15.1	10	CFS-C P 125/5”	4	EI 120-U/C

2.2.7.2.4 PE-100RC pipes “Wavin TS” - U/C

Manufacturer: Wavin Ireland Ltd.

Pipe		Insulation	Collar size (A ₃)	No. of hooks	Classification
diameter (d _c) [mm]	wall thickness (t _c) [mm]	thickness (t _D) [mm]			
50	4.6	9	CFS-C P 63/2”	2	EI 120-U/C
63	5.8	10	CFS-C P 75/2.5”	3	EI 120-U/C
75	6.8	10	CFS-C P 90/3”	3	EI 120-U/C
90	8.2	10	CFS-C P 110/4”	4	EI 120-U/C
110	10.0	10	CFS-C P 125/5”	4	EI 120-U/C

2.2.7.2.5 PVC-C pipes “Friatherm starr”,

Manufacturer: Friatec

Pipe		Insulation	Collar size (A ₃)	No. of hooks	Classification
diameter (d _c) [mm]	wall thickness (t _c) [mm]	thickness (t _D) [mm]			
32	3.6	9	CFS-C P 50/1.5”	2	EI 120-U/C
40	4.5	9	CFS-C P 63/2”	2	EI 120-U/C
50	5.6	9	CFS-C P 63/2”	2	EI 120-U/C
63	7.1	10	CFS-C P 75/2.5”	3	EI 120-U/C

2.2.7.3 PE pipes (C) according to EN 1519¹⁸ (C) with continued insulation (D) – interrupted – U/U

Pipe		Insulation	Collar size (A ₃)	No. of hooks	Classification
diameter (d _c) [mm]	wall thickness (t _c) [mm]	thickness (t _D) [mm]			
110	4.2	10	CFS-C P 160/6”	4	EI 90-U/U

The results are also valid for PE pipes according to EN 12201-2 and EN 12666-1.

2.2.7.4 Pipes (C) with local insulation (D) – sustained – U/C**2.2.7.4.1 PE-X pipes according EN ISO 15875**

Pipe		Insulation		Collar size (A ₃)	No. of hooks	Classification
diameter (d _c) [mm]	wall thickness (t _c) [mm]	thickness (t _D) [mm]	length (L _D) [mm]			
40	5.5	9	≥250	CFS-C P 50/1.5”	2	EI 90-U/C
50	6.9	9	≥250	CFS-C P 63/2”	2	EI 90-U/C
63	8.6	10	≥250	CFS-C P 75/3”	3	EI 90-U/C

2.2.7.4.2 PP pipes “Fusiotherm SDR 11”

Manufacturer: Aquatherm

Pipe		Insulation		Collar size (A ₃)	No. of hooks	Classification
diameter (d _c) [mm]	wall thickness (t _c) [mm]	thickness (t _D) [mm]	length (L _D) [mm]			
40	3.7	9	≥200	CFS-C P 50/1.5”	2	EI 120-U/C
50	4.6	9	≥200	CFS-C P 63/2”	2	EI 120-U/C
75	6.8	10	≥200	CFS-C P 90/3”	3	EI 120-U/C
110	10.0	10	≥200	CFS-C P 125/5”	4	EI 120-U/C

2.2.7.4.3 PP pipes “Fusiotherm Faser SDR 7.4/S3.2”

Manufacturer: Aquatherm

Pipe		Insulation		Collar size (A ₃)	No. of hooks	Classification
diameter (d _c) [mm]	wall thickness (t _c) [mm]	thickness (t _D) [mm]	length (L _D) [mm]			
40	5.5	9	≥200	CFS-C P 50/1.5”	2	EI 120-U/C
50	6.9	9	≥200	CFS-C P 63/2”	2	EI 120-U/C
75	10.3	10	≥200	CFS-C P 90/3”	3	EI 120-U/C
110	15.1	10	≥200	CFS-C P 125/5”	4	EI 120-U/C

2.2.7.4.4 PE-100RC pipes “Wavin TS”

Manufacturer: Wavin

Pipe		Insulation		Collar size (A ₃)	No. of hooks	Classification
diameter (d _c) [mm]	wall thickness (t _c) [mm]	thickness (t _D) [mm]	length (L _D) [mm]			
50	4.6	9	≥200	CFS-C P 63/2”	2	EI 120-U/C
63	5.8	10	≥200	CFS-C P 75/2.5”	3	EI 120-U/C
75	6.8	10	≥200	CFS-C P 90/3”	3	EI 120-U/C
90	8.2	10	≥200	CFS-C P 110/4”	4	EI 120-U/C
110	10.0	10	≥200	CFS-C P 125/5”	4	EI 120-U/C

2.2.7.4.5 PVC-C pipes "Friatherm starr"						
Manufacturer: Friatec						
Pipe		Insulation		Collar size (A ₃)	No. of hooks	Classification
diameter (d _c) [mm]	wall thickness (t _c) [mm]	thickness (t _D) [mm]	length (L _D) [mm]			
32	3.6	9	≥200	CFS-C P 50/1.5"	2	EI 120-U/C
40	4.5	9	≥200	CFS-C P 63/2"	2	EI 120-U/C
50	5.6	9	≥200	CFS-C P 63/2"	2	EI 120-U/C
63	7.1	10	≥200	CFS-C P 75/2.5"	3	EI 120-U/C

2.2.8 Plastic pipes with Hilti Firestop Collar CFS-C

Construction details (for symbols and abbreviations see Annex 4):

Hilti Firestop Collars CFS-C (A₃) are installed on both sides of the seal, fixed together by threaded rods, washers and nuts as specified in Annex 1.2.

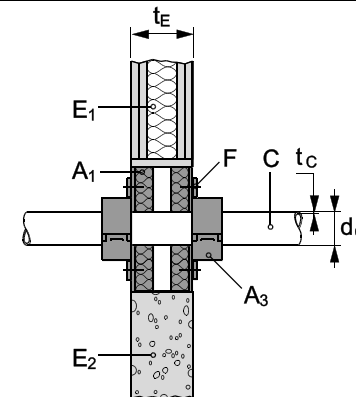

2.2.8.1 PVC-U pipes (C) according to EN ISO 1452-2, EN ISO 15493, DIN 8061/8062

Pipe diameter (d _c) [mm]	Pipe wall thickness (t _{c1}) [mm]	Collar size (A ₃)	No. of hooks	Classification
50	2.4 – 5.6	CFS-C 50/1.5"	2	EI 120-U/C
63	3.0 – 4.7	CFS-C 63/2"	2	EI 120-U/C
75	2.2 – 3.6	CFS-C 75/2.5"	3	EI 120-U/C
90	2.7 – 4.3	CFS-C 90/3"	3	EI 120-U/C
110	1.8 – 8.1	CFS-C 110/4"	4	EI 120-U/C
125	3.7 – 6.0	CFS-C 125/5"	4	EI 120-U/C
160	2.5 – 11.8	CFS-C 160/6"	4	EI 120-U/C

The results are also valid for PVC-U pipes according EN 1329-1¹⁶ and EN 1453-1¹⁷ as well as PVC-C pipes according EN 1566-1

2.2.8.2 PE pipes (C) according to EN ISO 15494, DIN 8074/8075

Pipe diameter (d _c) [mm]	Pipe wall thickness t _c [mm]	Collar size (A ₃)	No. of hooks	Classification
50	2.9 – 4.6	CFS-C 50/1.5"	2	EI 120-U/C
63	1.8 – 5.8	CFS-C 63/2"	2	EI 120-U/C
75	1.9 – 6.8	CFS-C 75/2.5"	3	EI 120-U/C
90	2.2 - 8.2	CFS-C 90/3"	3	EI 120-U/C
110	2.7 – 10.0	CFS-C 110/4"	4	EI 120-U/C
125	3.1 – 7.1	CFS-C 125/5"	4	EI 120-U/C
160	4.0 – 9.1	CFS-C 160/6"	4	EI 120-U/C

2.2.8.3 PE pipes (C) according to EN 1519¹⁸

Pipe diameter (d _c) [mm]	Pipe wall thickness t _c [mm]	Collar size (A ₃)	No. of hooks	Classification
50	3.0	CFS-C 50/1.5"	2	EI 120-U/C
63	3.0	CFS-C 63/2"	2	EI 120-U/C
75	3.0	CFS-C 75/2.5"	3	EI 120-U/C
90	3.5	CFS-C 90/3"	3	EI 120-U/C
110	4.2	CFS-C 110/4"	4	EI 120-U/C
125	4.8	CFS-C 125/5"	4	EI 120-U/C
160	6.2	CFS-C 160/6"	4	EI 120-U/C

The results are also valid for PE pipes according to EN 12201-2 and EN 12666-1.

2.2.9 Plastic pipes with Hilti Firestop Collar Endless CFS-C EL

Construction details (for symbols and abbreviations see Annex 4):

Hilti Firestop Collar Endless CFS-C EL has to be installed around the pipe on each side of the wall.

Wall type:

- Flexible, fire rated wall acc.2.1a), minimum thickness 100mm
- Rigid, fire rated wall acc.2.1b), minimum thickness 100mm

Hilti Firestop Collar Endless CFS-C EL should be fixed in mineral wool boards using Threaded rods minimum M6 with flat washer and nut, penetrating the boards.

Pipes have to be grouped in lines only; number of pipes in line is not limited.

Minimum distances

- between pipes in single penetration: $\geq 200\text{mm}$
- between pipes in one line: $\geq 80\text{mm}$
- between two lines of pipes: $\geq 200\text{mm}$
- between pipe and building element $\geq 0\text{mm}$

Gap sealing (board to building element and board to penetrating pipe) should be done with CFS-S ACR. Coated Boards have to be installed flush with wall surface. If the wall thickness is bigger than 100mm the free space between both boards has to be closed around penetrating plastic pipes with mineral wool, at least 100mm around the plastic pipes. Pipes could be covered with a sound decoupling insulation, penetrating the wall and all installed jackets CFS-C EL in LS and CS situation. Sound decoupling insulation comprise a max.9mm polyethylene based insulation or a max. 4mm Polyester insulation (*Thermaflex, ThermoVließ B2*)

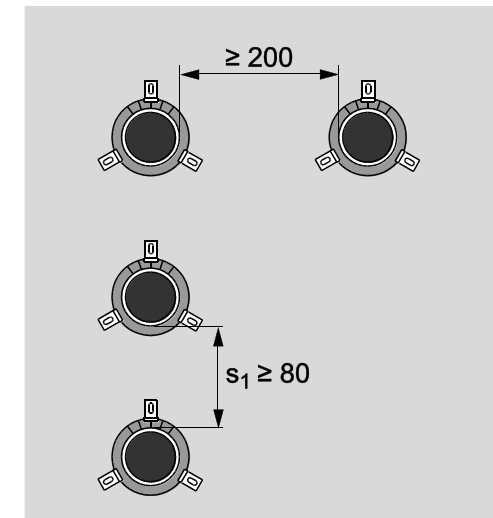
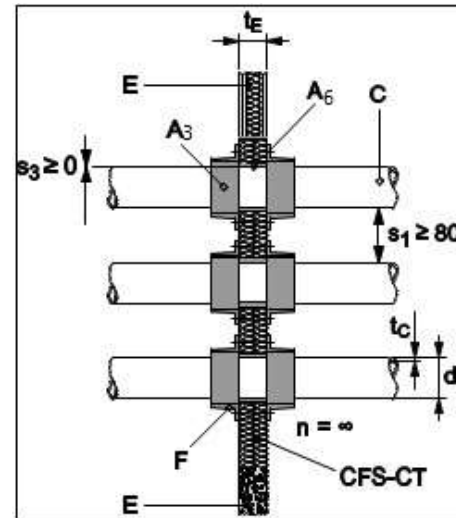

2.2.9.1 Plastic pipes acc. EN 1519-1, EN 12666-1, EN 12201-2 and ABS-pipes acc. EN 1455-1 and SAN+PVC-pipes acc. EN 1565-1

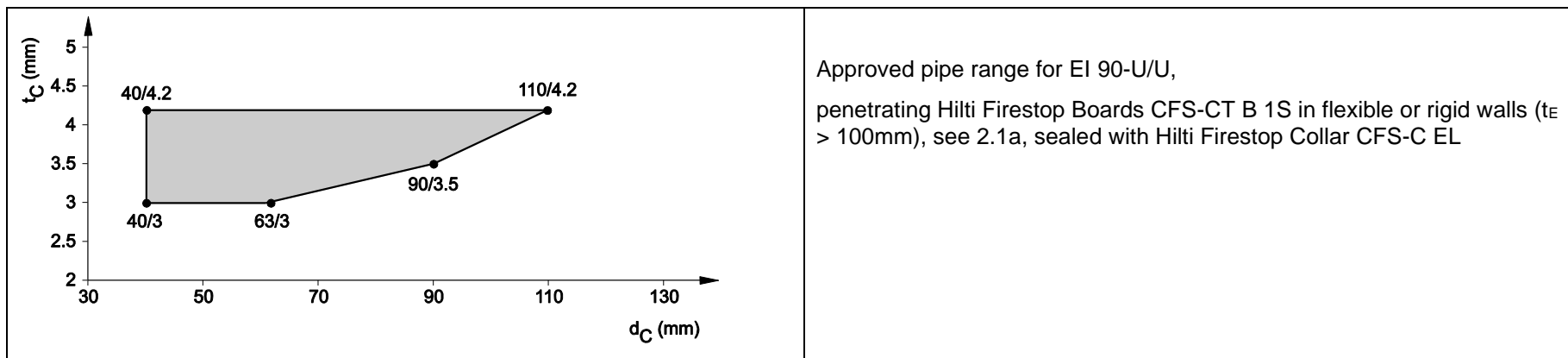

2.2.9.2 ABS- pipes acc. EN 1455, EN 15493 and SAN+PVC-pipes acc. EN 1565-1, penetrating Hilti Firestop Boards CFS-CT B 1S

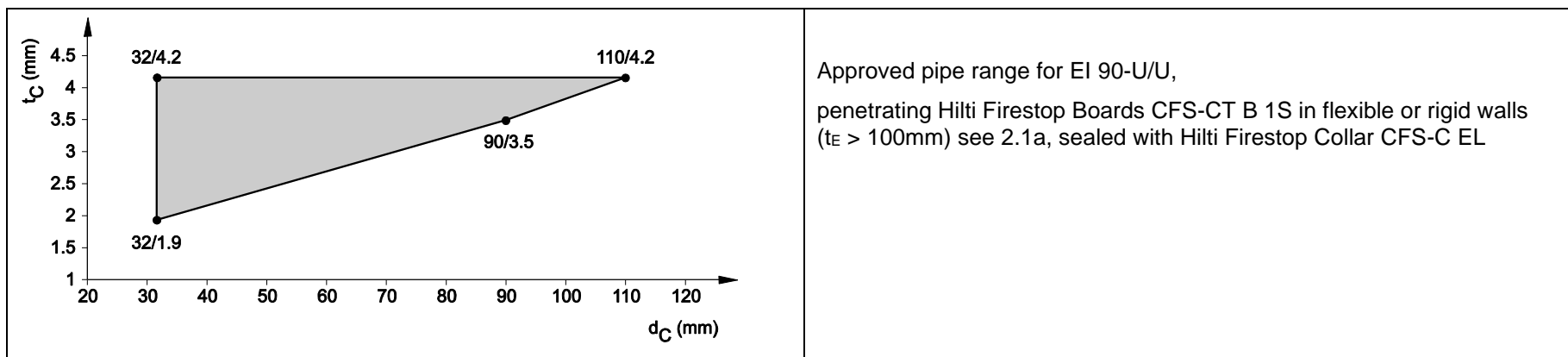

2.2.9.3 PE pipes acc. EN15494, EN12201-2 and DIN 8074/75

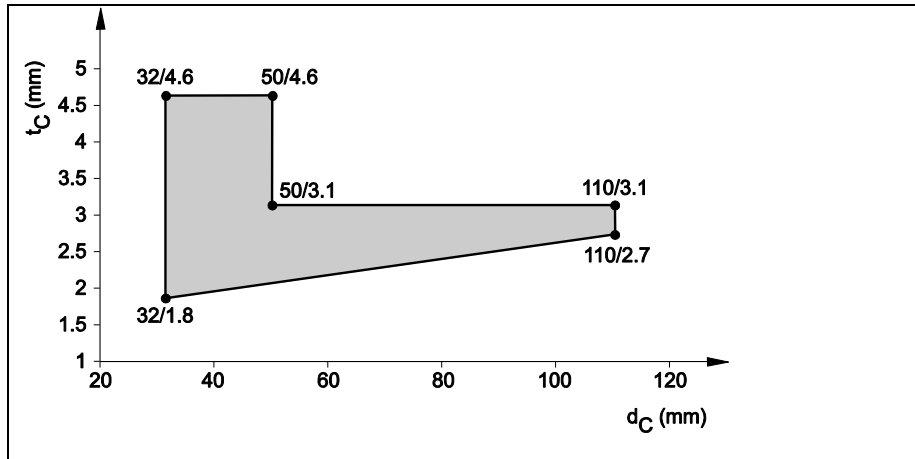

Approved pipe range for EI90-U/U,
penetrating Hilti Firestop Boards CFS-CT B 1S in flexible or rigid walls
(t_E > 100mm), see 2.1.a), sealed with Hilti Firestop Collar CFS-C EL

2.2.9.4 PVC pipes acc. EN 1452-1, EN 1329-1, EN 1453-1, EN 1566-1, EN ISO 15493 and DIN 8061/62

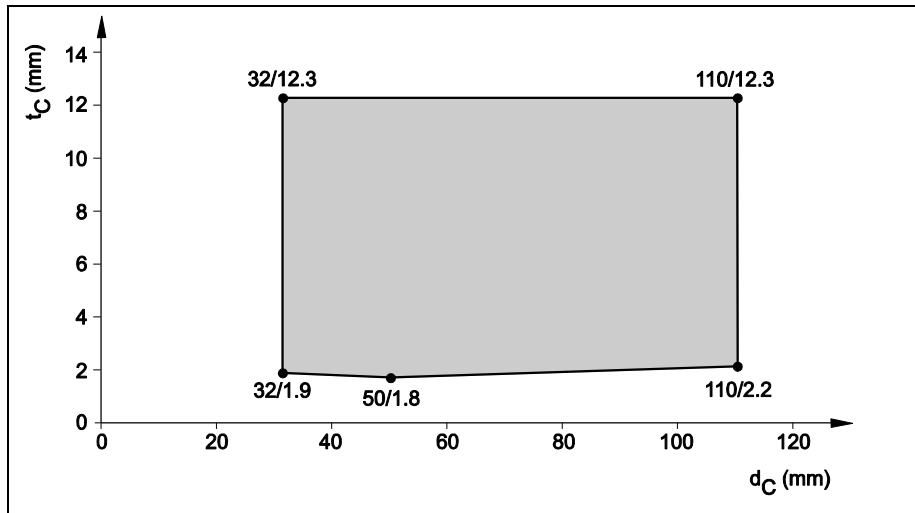

Approved pipe range for EI90-U/U,
penetrating Hilti Firestop Boards CFS-CT B 1S in flexible or rigid walls
(t_E > 100mm), see 2.1.a), sealed with Hilti Firestop Collar CFS-C EL

2.2.9.5 PP pipes, non-regulated

For approved pipe type/manufacturer refer to 2.1.6.

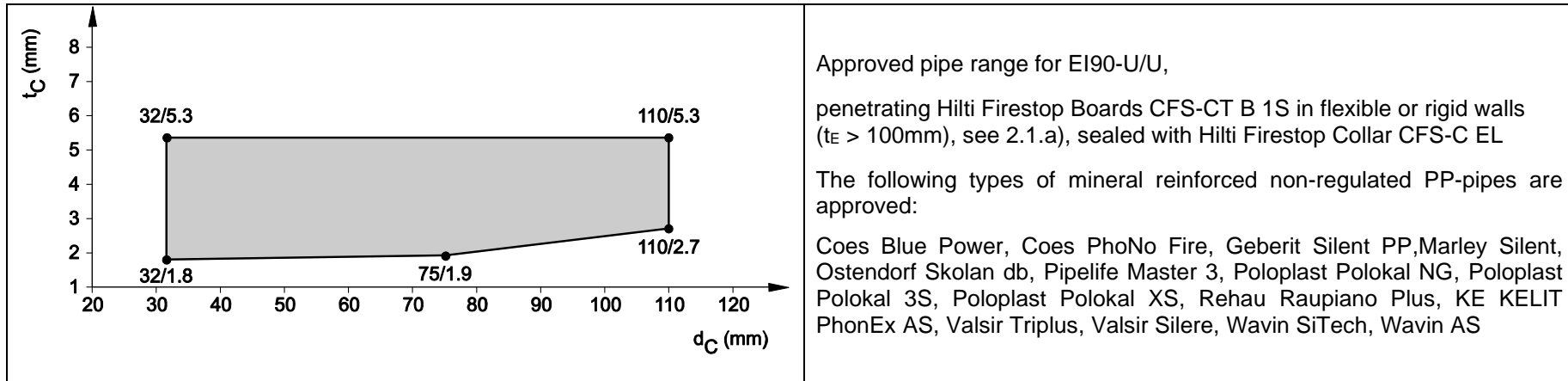

2.2.9.6 PP pipes acc. EN1451-1 and DIN 8077/78

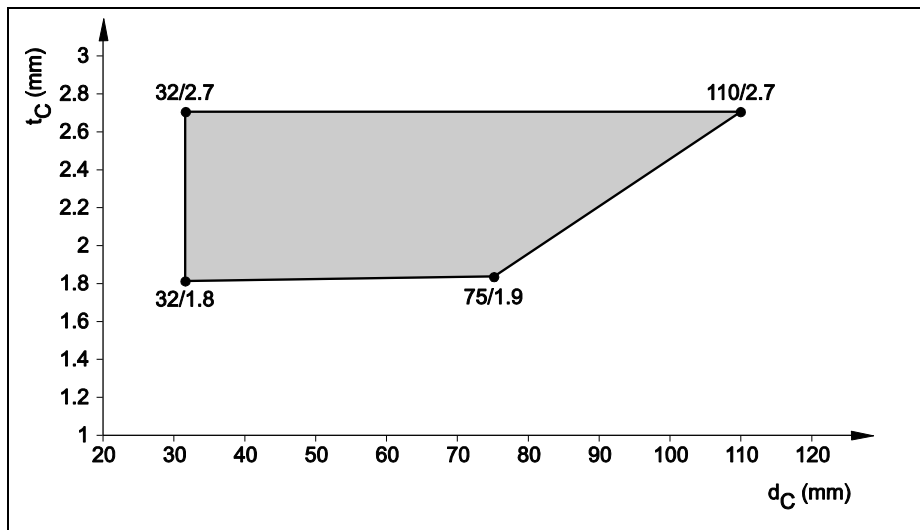

Approved pipe range for EI90-U/U,
penetrating Hilti Firestop Boards CFS-CT B 1S in flexible or rigid walls ($t_E > 100\text{mm}$), see 2.1.a), sealed with Hilti Firestop Collar CFS-C EL

2.2.9.7 PE pipes, non-regulated (Geberit Silent dB20)

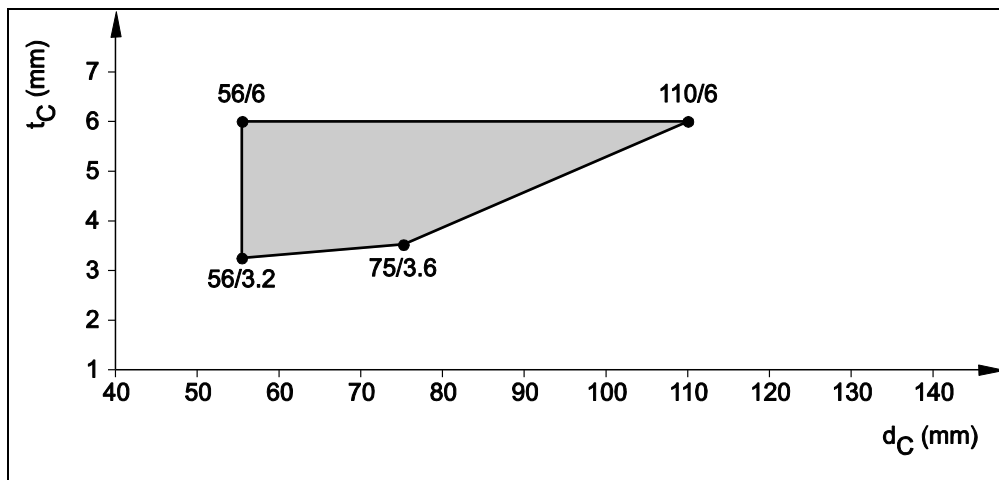

Approved pipe range for EI90-U/U,
penetrating Hilti Firestop Boards CFS-CT B 1S in flexible or rigid walls ($t_E > 100\text{mm}$), see 2.1.a), sealed with Hilti Firestop Collar CFS-C EL

2.2.10 Plastic pipes with Hilti Firestop Wrap CFS-W

Construction details (for symbols and abbreviations see Annex 4):

Hilti Firestop Wrap CFS-W EL or SG (A_4) is wrapped around the pipe on each side of the seal and positioned within the annular gap so that the outer edge of the wrap is flush with the surface of the wall as specified in Annex 1.2.

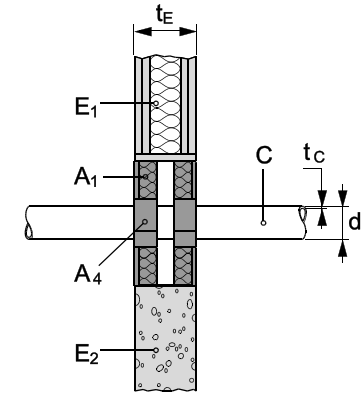

2.2.10.1 PVC-U pipes (C) according to EN ISO 1452-2, EN ISO 15493, DIN 8061/8062 – U/C

Pipe diameter (d_c) [mm]	Pipe wall thickness t_c [mm]	Wrap type (A_4)	Size (CFS-W SG) No. of layers (CFS-W EL)	Classification
50	2.2 – 3.6	CFS-W SG	50/1.5"	EI 90-U/C
63	2.2 – 3.6	CFS-W SG	63/2"	EI 90-U/C
75	2.2 – 3.6	CFS-W SG	75/2.5"	EI 90-U/C
≤ 75	2.2 – 3.6	CFS-W EL	1	EI 90-U/C
90	3.7 – 6.0	CFS-W SG	90/3"	EI 90-U/C
110	3.7 – 6.0	CFS-W SG	110/4"	EI 90-U/C
125	3.7 – 6.0	CFS-W SG	125/5"	EI 90-U/C
>75 ≤ 125	3.7 – 6.0	CFS-W EL	2	EI 90-U/C

The results are also valid for PVC-U pipes according EN 1329-116 and EN 1453-1¹⁷ and PVC-C pipes according EN 1566-1.

2.2.10.2 PE pipes (C) according to EN 1519 - U/C

Pipe diameter (d_c) [mm]	Pipe wall thickness t_c [mm]	Wrap type (A_4)	Size (CFS-W SG) No. of layers (CFS-W EL)	Classification
50	3.0	CFS-W SG	50/1.5"	EI 90-U/C

63	3.0	CFS-W SG	63/2"	EI 90-U/C
75	3.0	CFS-W SG	75/2.5"	EI 90-U/C
≤ 75	3.0	CFS-W EL	1	EI 90-U/C
90	4.8	CFS-W SG	90/3"	EI 90-U/C
110	4.8	CFS-W SG	110/4"	EI 90-U/C
125	4.8	CFS-W SG	125/5"	EI 90-U/C
>75 ≤ 125	4.8	CFS-W EL	2	EI 90-U/C

The results are also valid for PE pipes according to EN 12201-2 and EN 12666-1.

2.2.10.3 PE pipes (C) according to EN ISO 15494, DIN 8074/8075 – U/C

Pipe diameter (d _c) [mm]	Pipe wall thickness t _c [mm]	Wrap type (A ₄)	Size (CFS-W SG) No. of layers (CFS-W EL)	Classification
50	1.9 – 6.8	CFS-W SG	50/1.5"	EI 90-U/C
63	1.9 – 6.8	CFS-W SG	63/2"	EI 90-U/C
75	1.9 – 6.8	CFS-W SG	75/2.5"	EI 90-U/C
≤ 75	1.9 – 6.8	CFS-W EL	1	EI 90-U/C
90	3.2 – 7.1	CFS-W SG	90/3"	EI 90-U/C
110	3.2 – 7.1	CFS-W SG	110/4"	EI 90-U/C
125	3.2 – 7.1	CFS-W SG	125/5"	EI 90-U/C
>75 ≤ 125	3.2 – 7.1	CFS-W EL	2	EI 90-U/C

2.2.10.4 PP pipes (C) "Wavin AS" or "Phonex AS" – C/U Manufacturer: Wavin Ltd. or KeKelit

Pipe diameter (d _c) [mm]	Pipe wall thickness t _c [mm]	Wrap type (A ₄)	No. of layers (CFS-W EL)	Classification
≤78	4.5	CFS-W EL	1	EI 120-C/U

2.2.10.5 PP pipes (C) "Raupiano plus" – C/U Manufacturer: Rehau

Pipe diameter (d _c) [mm]	Pipe wall thickness t _c [mm]	Wrap type (A ₄)	No. of layers (CFS-W EL)	Classification
≤75	1.9	CFS-W EL	1	EI 120-C/U

**2.2.10.6 PE-S2 pipes (C) “Geberit Silent db20”
Manufacturer: Geberit**

Pipe diameter (d _c) [mm]	Pipe wall thickness t _c [mm]	Wrap type (A ₄)	No. of layers (CFS-W EL)	Classification
≤75	3.6	CFS-W EL	1	EI 120-C/U

2.2.11 AI-Composite pipes with foamed elastomeric insulation according to Table 4 and Hilti Firestop Collar CFS-C P

Construction details (for symbols and abbreviations see Annex 4):

For specification of the foamed elastomeric insulation material to be used see Table 4.

Hilti Firestop Collars CFS-C P (A₃) are installed on both sides of the seal, fixed together by threaded rods, washers and nuts as specified in Annex 1.2.

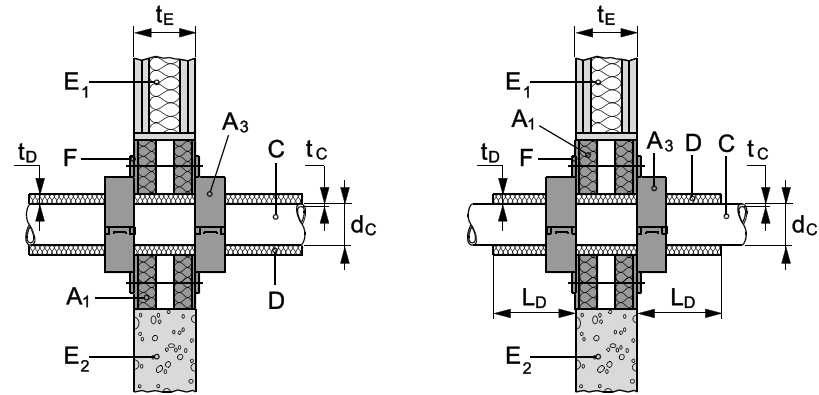

2.2.11.1 Pipes (C) with continued insulation (D) – sustained – U/C

PE-Xb/AI/PE-HD “Geberit Mepla”

Manufacturer: Geberit

Pipe		Insulation	Collar size (A ₃)	No. of hooks	Classification
diameter (d _c) [mm]	wall thickness (t _c) [mm]	thickness (t _D) [mm]			
40	3.5	9	CFS-C P 50/1.5”	2	EI 60-U/C
50	4.0	9	CFS-C P 63/2”	2	EI 60-U/C

PE-Xa/AI/PE-HD “Rautitan stabil”

Manufacturer: Rehau

Pipe		Insulation thickness (t _D) [mm]	Collar size (A ₃)	No. of hooks	Classification
diameter (d _c) [mm]	wall thickness (t _c) [mm]				
40	6.0	9	CFS-C P 50/1.5”	2	EI 60-U/C

PE-X/Al/PE "KELOX KM 110"

Manufacturer: KeKelit Kunststoffwerk

Pipe		Insulation thickness (t _b) [mm]	Collar size (A ₃)	No. of hooks	Classification
diameter (d _c) [mm]	wall thickness (t _c) [mm]				
50	4.5	9	CFS-C P 50/1.5"	2	EI 60-U/C
63	6.0	9	CFS-C P 75/2.5"	3	EI 60-U/C

2.2.12 AI-Composite pipes with foamed elastomeric insulation according Table 4 and Hilti Firestop Bandage CFS-B

Construction details (for symbols and abbreviations see Annex 4):

For specification of the foamed elastomeric insulation material to be used see Table 4.

Two layers of Firestop Bandage CFS-B (A_2) wrapped around the pipe insulation, on each side of the seal. The bandage is positioned with half of its width (62.5 mm) within the seal (central marking line at the surface of the seal) and outside the seal fixed with wire.

Over of the bandage/pipe insulation additional protection AP_6 or AP_7 according to 1.2 is installed:

AP_6 : Armaflex AF19 pipe insulation wrapped around the bandage/pipe insulation on each side of the seal, fixed with wire, length (L_{AP}) = 300 mm on each side, thickness (t_{AP}) = 19 mm.

AP_7 : Mineral wool mat according to Table 2, wrapped around the bandage/pipe insulation on each side of the seal, fixed with wire, length (L_{AP}) = 300 mm, thickness (t_{AP}) = 20 mm.

Continued insulation, sustained (CS)

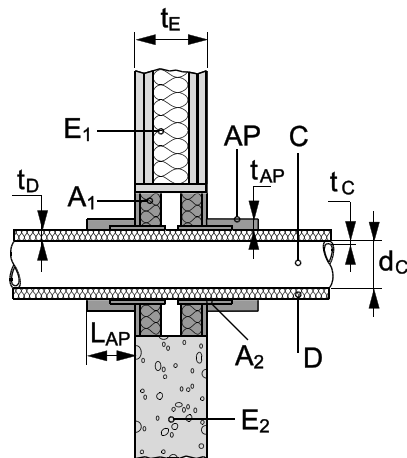

Local insulation, sustained (LS)

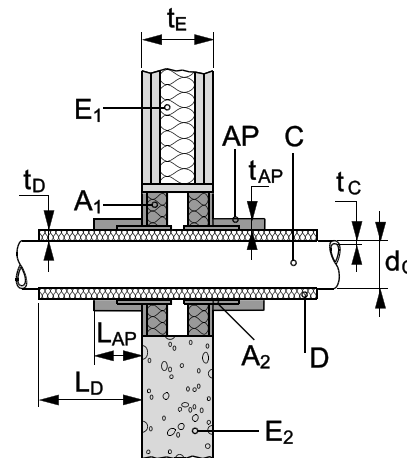

2.2.12.1 AI-composite pipes (C) with continued insulation (D) – sustained – U/C

PE-Xb/Al/PE-HD pipes „Geberit Mepla“

Manufacturer: Geberit

Pipe		Insulation		Additional protection	Classification
diameter (dc) [mm]	wall thickness (tc) [mm]	thickness (tD) [mm]			
16	2.25	10 - 32		AP ₆	EI 120-U/C
26 - 63	3.0 - 4.5	10 - 32		AP ₆	EI 120-U/C
16	2.25	10 - 32		AP ₇	EI 90-U/C
32	3.0	10 - 32		AP ₇	EI 90-U/C
40 - 63	3.5 - 4.5	10 - 32		AP ₇	EI 120-U/C
32	3.0	32		AP ₇	EI 120-U/C

2.2.12.2 AI-composite pipes (C) with local insulation (D) – sustained – U/C

PE-Xb/Al/PE-HD pipes „Geberit Mepla“

Manufacturer: Geberit

Pipe		Insulation		Additional protection	Classification
diameter (dc) [mm]	wall thickness (tc) [mm]	thickness (t _D) [mm]	length (L _D) [mm]		
16	2.25	10 - 32	≥ 450	AP ₆	EI 120-U/C
26 - 63	3.0 - 4.5	10 - 32	≥ 450	AP ₆	EI 120-U/C
16	2.25	10 - 32	≥ 450	AP ₇	EI 90-U/C
32	3.0	10 - 32	≥ 450	AP ₇	EI 90-U/C
40 - 63	3.5 - 4.5	10 - 32	≥ 450	AP ₇	EI 120-U/C
32	3.0	32	≥ 450	AP ₇	EI 120-U/C

2.2.13 AI-composite pipes with mineral wool insulation according to Table 3

Construction details (for symbols and abbreviations see Annex 4):

Continued insulation, sustained (CS)

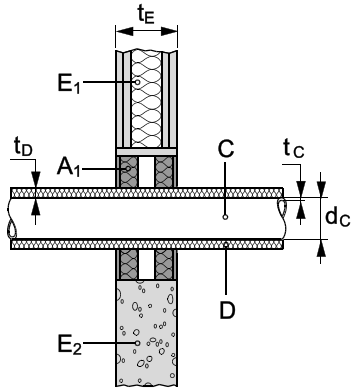

Local insulation, sustained (LS)

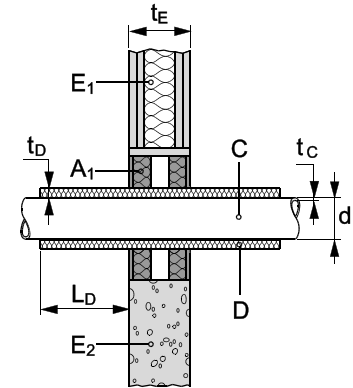

2.2.13.1 Pipes (C) with continued insulation (D) – sustained – U/C

PE-Xb/Al/PE-HD pipes „Geberit Mepla“

Manufacturer: Geberit

Pipe diameter (d_c) [mm]	Pipe wall thickness (t_c) [mm]	Insulation thickness (t_D) [mm]	Classification
16 - 32	2.0 – 3.0	≥ 20	EI 120-U/C

VPE/Al/VPE pipes „Kelox KM 110“

Manufacturer: KeKelit

Pipe diameter (d_c) [mm]	Pipe wall thickness (t_c) [mm]	Insulation thickness (t_D) [mm]	Classification
16 - 32	2.0 – 3.0	≥ 20	EI 120-U/C
16.2 - 32	2.6 – 4.7	≥ 20	EI 120-U/C

2.2.13.2 Pipes (C) with local insulation (D) – sustained – U/C**PE-Xb/Al/PE-HD pipes „Geberit Mepla“**

Manufacturer: Geberit

Pipe		Insulation		Classification
diameter (d _c) [mm]	wall thickness (t _c) [mm]	thickness (t _D) [mm]	length (L _D) [mm]	
16 - 32	2.0 – 3.0	20	≥ 250	EI 120-U/C

VPE/Al/VPE pipes „Kelox KM 110“

Manufacturer: KeKelit

Pipe		Insulation		Classification
diameter (d _c) [mm]	wall thickness (t _c) [mm]	thickness (t _D) [mm]	length (L _D) [mm]	
16 - 32	2.0 – 3.0	20	≥ 250	EI 120-U/C

PE-Xa/Al/PE-HD pipes „Rautitan stabil“

Manufacturer: Rehau

Pipe		Insulation		Classification
diameter (d _c) [mm]	wall thickness (t _c) [mm]	thickness (t _D) [mm]	length (L _D) [mm]	
16.2 - 32	2.6 – 4.7	20	≥ 250	EI 120-U/C

2.2.14 Plastic pipes with Hilti Firestop Wrap CFS-W P

Construction details (for symbols and abbreviations see Annex 4):

Flexible walls acc.2.1a): The wall must have a minimum thickness of 100 mm and comprise timber or steel studs covered on both faces with minimum 2 layers of 12,5 mm thick boards. A higher number of board layers are accepted if the overall board layer thickness is equal or bigger than tested. A higher overall board layer thickness is accepted, if the number of board layers is equal or bigger than tested.

For timber stud walls there must be a minimum distance of 100 mm of the seal to any stud and the cavity between stud and seal must be closed. A minimum 100 mm insulation of Class A1 or A2 (in accordance with EN 13501-1) has to remain in the cavity between stud and seal. In steel stud construction the space between linings has not to be completely filled with insulation material, especially in the neighbourhood to the seal. Nevertheless the wall construction has to be set up according requirements given in EN 1366-3:2009 or the construction itself has been classified according EN 13501-2.

Rigid wall: The wall must have a minimum thickness 100 mm and comprise concrete, aerated concrete or masonry, having a minimum density of 650 kg/m³, see point 2.1.

Hilti Firestop Wrap CFS-W P is a graphite based strip with a width of 50mm and a thickness of 2mm. Used length depends from pipe diameter, pipe insulation and construction group (CG).

No Z-profiles have to be used in wall application of CFS-W P.

The boards are placed into the opening of the wall construction in a way that the visible sites are installed flush with wall surface. In case of a thicker wall (> 100mm) the penetrants should be wrapped in between both boards with mineral wool (refer to Annex 2, 2.1.3,AP9).

The pipes may only be installed horizontal, perpendicular to the penetration seal. Distance from wall surface to nearest pipe support position is equal to or smaller than 250mm.

Hilti Firestop Wrap CFS-W P (A₁) to be mounted on both sides of the Hilti Firestop Double Board Seal CFS-CT. Annular gap between the pipe sealing and the double board sealed with Hilti Firestop Acrylic Sealant CFS-S ACR – material (A₂): water based acrylic sealant. The wrap comes 5 mm further than the board surface on both sides of the wall.

2.2.14.1 Plastic pipes, sealed with Hilti Firestop Wrap CFS-W P – seal design variations in wall

Seal design type		Sealing product (A ₁)		Annular sealing (A ₂)	Principle drawings
i)	Uninsulated Plastic Pipe	CFS-W P	Standard number of layers	Acrylic sealant CFS-S ACR	
ii)	Insulated (CS) Plastic Pipe	CFS-W P	Standard number of layers	Acrylic sealant CFS-S ACR	

<p>iii)</p>	<p>Insulated (CS) Aluminium composite Pipe, elastomeric foamed insulation (see ann. 1- 1.2.12 table 4)</p>	<p>CFS-W P</p>	<p>Standard number of layers</p>	<p>Acrylic sealant CFS-S ACR</p>	
<p>iv)</p>	<p>Insulated (CS) Metal Pipe with add. protection D₁* (l_{D1}=50 mm), elastomeric foamed insulation (see ann. 1 - 1.2.12 table 4)</p>	<p>CFS-W P</p>	<p>Standard number of layers</p>	<p>Acrylic sealant CFS-S ACR</p>	

2.2.14.2 Foamed elastomeric insulation

The following types of foamed elastomeric insulation material may be used in direct contact ($s_1 \geq 0$ mm) to Hilti Firestop Wrap CFS-W P: see annex 1, chapter 1.2.12, table 4

Named material may be used in form of an insulation hose, bandage/wrap or plates. If a protect insulation D is used, it should be made of the same elastomeric material as the thermal pipe isolation itself. Pipe insulation could be used in LS and CS situation.

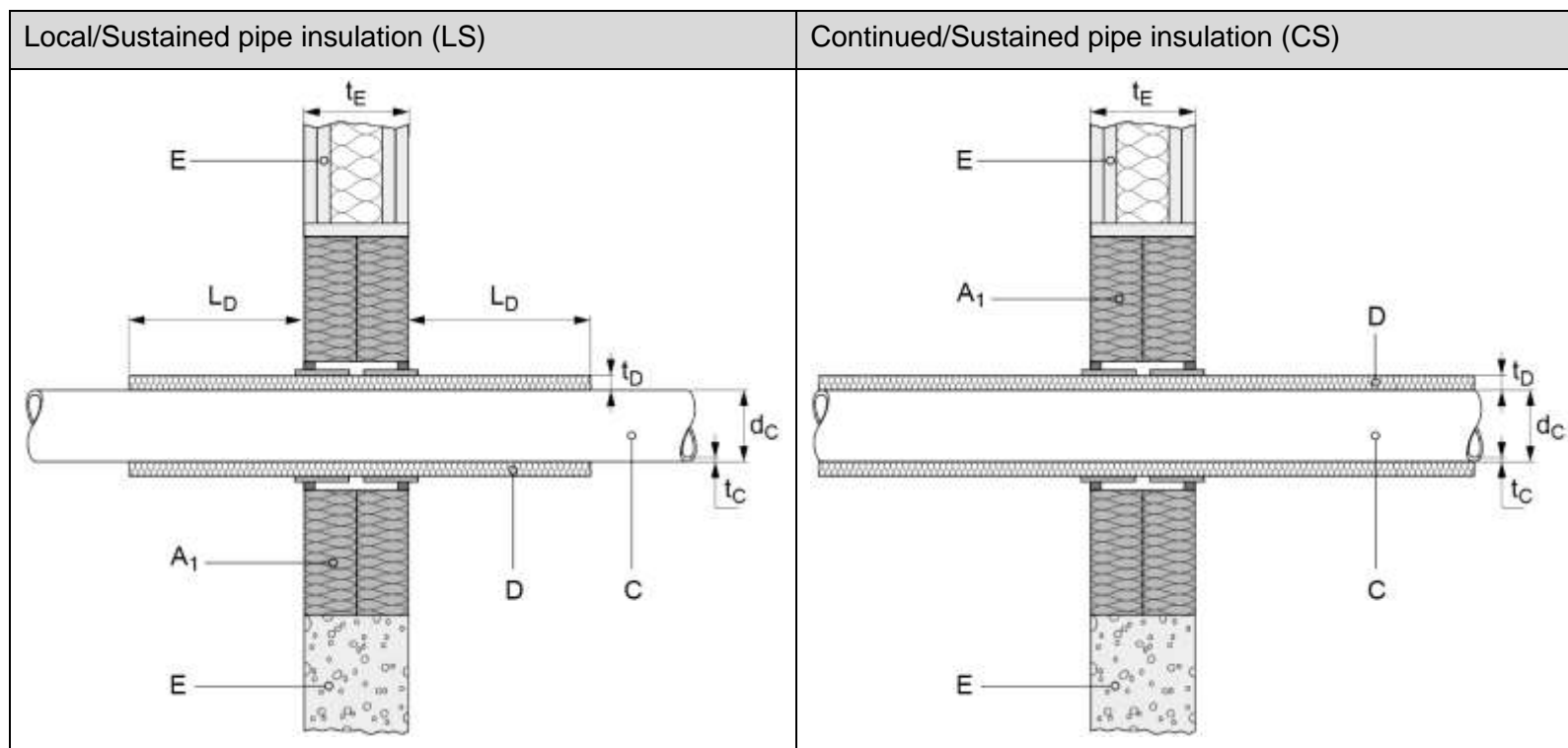

2.2.14.3 Pipes, sealed with Hilti Firestop Wrap CFS-W P – construction groups

There are several construction groups which define the number of layers of the Hilti Firestop Wrap CFS-W P, wrapped around the plastic pipes, penetrating the boards CFS-CT.

The number of specific construction group relates always to the number of layers of CFS-W P. (For instance; construction group 4 means always 4 wrapped layers of CFS-W P.)

If the pipe is used in a U/U pipe end configuration, following number of layers is to apply.

Layer group	Diameter range (mm)	Number of layers
2	32 to 56	2
3	63 to 75	3
4	90 to 125	4
5*	90 to 110	5
6	>135 to 160	6

* This construction group is only used for PE-pipes provided with Elastomeric insulation

If the pipe is used in a U/C pipe end configuration, following number of layers have to apply.

Layer group	Diameter range (mm)	Number of layers
1	32 to 63	1
2	>63 to 110	2
4	>110 to 160	4

Aluminium composite pipes :

Layer group	Diameter range (mm)	Number of layers
1	16 to 40	1
2	56 to 75	2

Metal pipes :

Layer group	Diameter range (mm)	Number of layers
1	10 to 42	1
2	> 42 to 114	2
3	> 114 to 219	3

2.2.14.4 Pipe support construction

All penetrating pipes have to be supported at maximum 250 mm away from both faces of any walls.

2.2.14.5 Separation of penetrations

General distance rules given in 2.2 are not valid for chapters 2.2.14, 2.2.15 and 2.2.16 (and their sub-chapters)

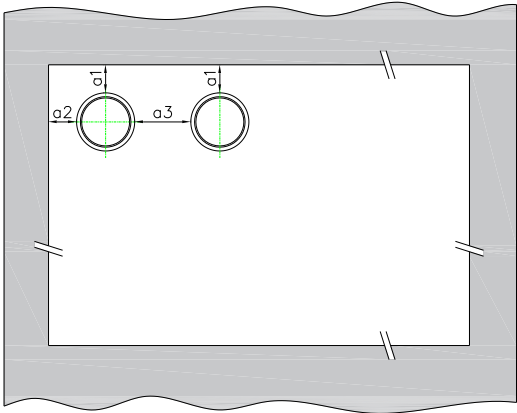
	<p>For separations $a_1 - a_3$, please see detailed description in clause 2.2.14, 2.2.15, 2.2.16 and following sub-chapters.</p>
---	---

2.2.14.6 Plastic pipes sealed with Hilti Firestop Wrap CFS-W P penetrating a double board seal CFS-CT in wall

2.2.14.6.1 PE - pipes according to EN 1519-1, EN 12666-1, EN 12201-2 for EI 90-U/U

PE - pipes according to EN 1519-1, EN 12666-1, EN 12201-2; Seal design: i) according to 2.2.11.1						
Construction group	Pipe diameter \varnothing dc (mm)	Pipe wall thickness tc (mm)	Separation a1 (mm)	Separation a2 (mm)	Separation a3 (mm)	Classification
2	32 to 56	3,0	25	25	50	EI 90-U/U, E 90-U/U
3	> 56 to 75	3,0	25	25	50	
4	> 75 to 125	3,5 to 4,8	25	25	50	
6	> 125 to 160	6,2	25	25	50	

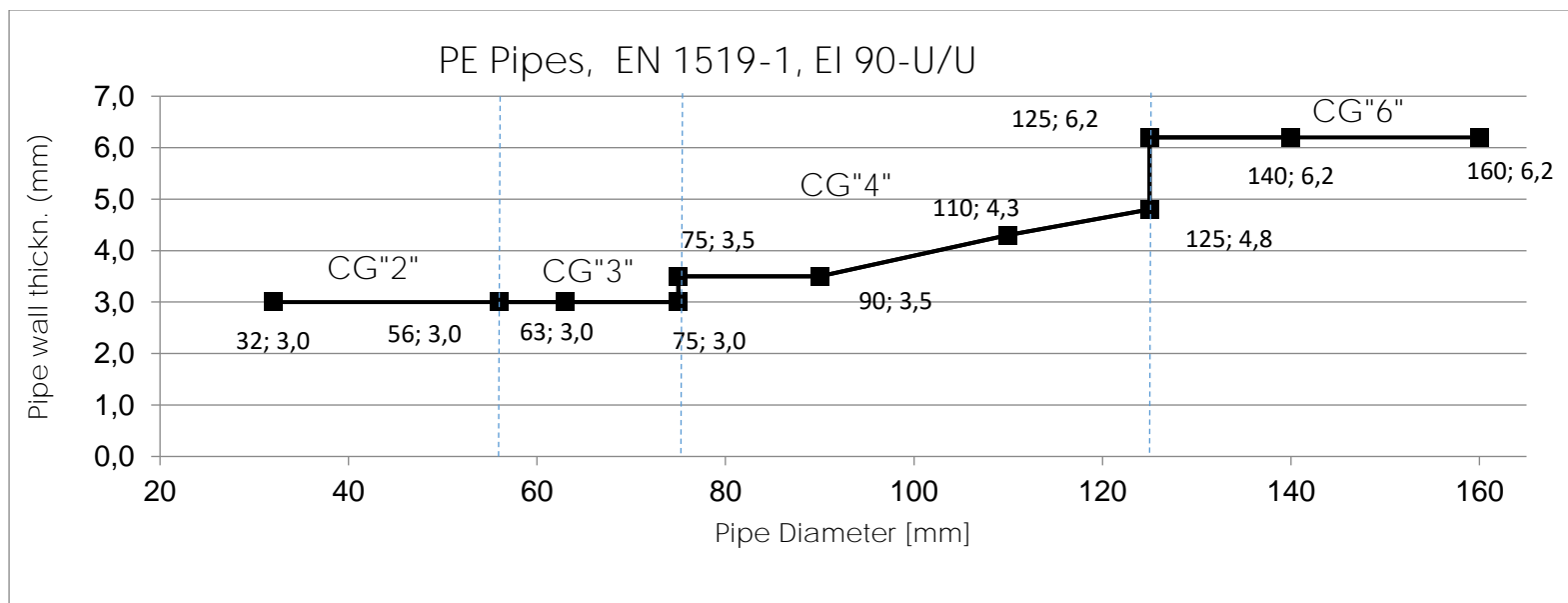

2.2.14.6.2 PE – pipes according to EN 1519-1, EN 12666-1, EN 12201-2 for EI 120-U/U

PE pipes according to EN 1519-1, EN 12666-1, EN 12201-2 ; Seal design: i) according to 2.2.11.1						
Construction group	Pipe diameter Ø dc (mm)	Pipe wall thickness tc (mm)	Separation a1 (mm)	Separation a2 (mm)	Separation a3 (mm)	Classification
2	32 to 56	3,0	185	60	70	EI 120-U/U; E 120-U/U
3	> 56 to 75	3,0	126	31	100	
4	> 75 to 125	4,3 to 4,9	25	50	50	
6	> 125 to 160	6,2	58	158	≥ 200	

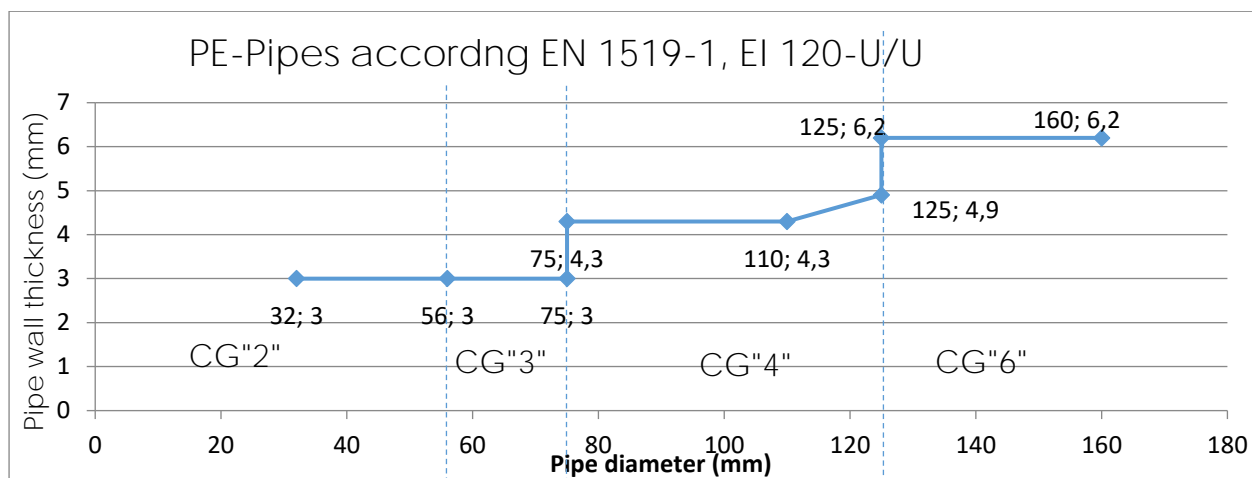

2.2.14.6.3 PE – pipes (isolated) acc.to EN 1519-1, EN 12666-1, EN 12201-2 for EI 90-U/U

Isolated PE pipes according to EN 1519-1, EN 12666-1, EN 12201-2 ; Seal design: ii) according to 2.2.11.1, Elastomeric Insulation: refer to 1.2.12 table 4							
Construction group	Pipe diameter Ø dc (mm)	Pipe wall thickness tc (mm)	Pipe insulation thickness (mm)	Separation a1 (mm)	Separation a2 (mm)	Separation a3 (mm)	Classification
2	32 to 56	3,0	9,0 to 21,5	25	25	50	EI 90-U/U; E 120-U/U
4	> 56 to 75	3,0	9,5 to 22,0	25	25	50	
5	> 75 to 110	3,5 to 4,3	9,5 to 23,0	25	25	50	

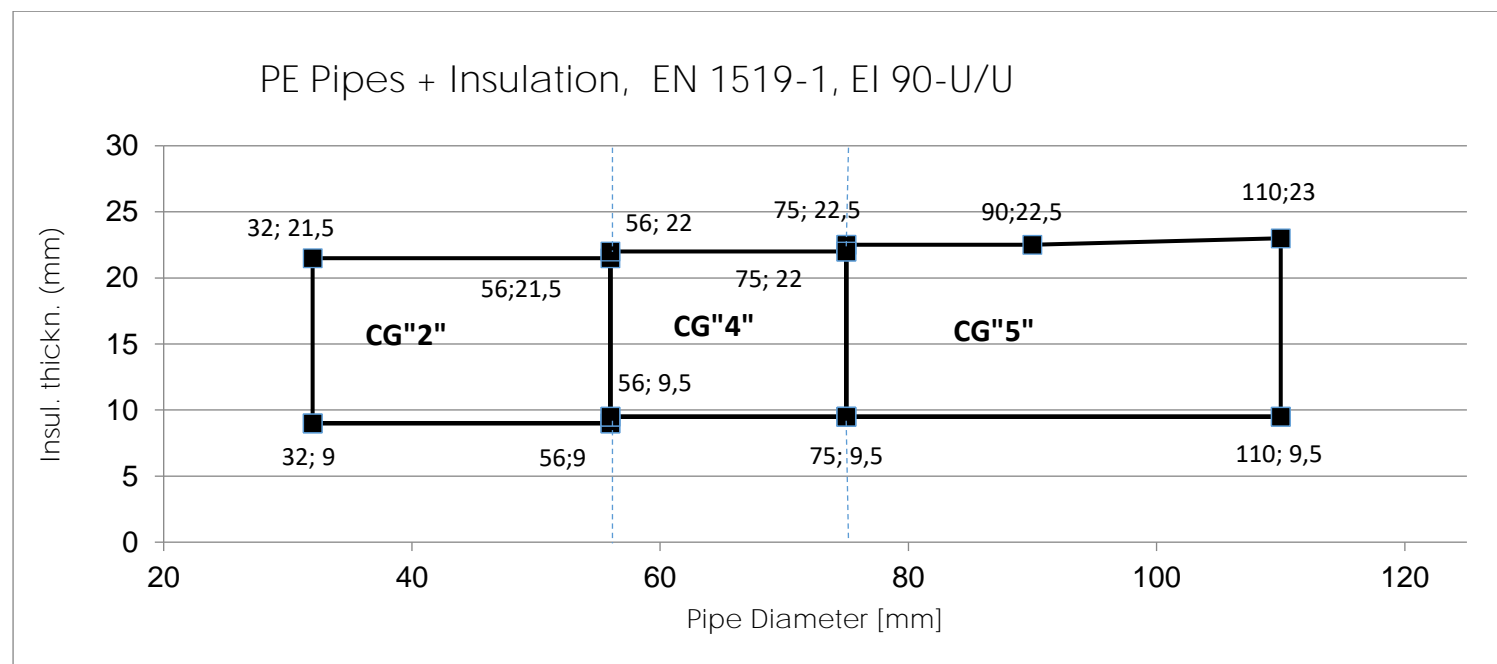

2.2.14.6.4 PE – pipes (isolated) acc. to EN 1519-1, EN 12666-1, EN 12201-2 for EI 120-U/U

Isolated PE pipes according to EN 1519-1, EN 12666-1, EN 12201-2 ; Seal design: ii) according to 2.2.11.2							
Construction group	Pipe diameter Ø dc (mm)	Pipe wall thickness tc (mm)	Pipe insulation thickness (mm)	Separation a1 (mm)	Separation a2 (mm)	Separation a3 (mm)	Classification
2	32 to 56	3,0	9,0 to 21,5	141	50	50	EI 120-U/U; E 120-U/U
5	110	4,3	9,5	100	50	70	

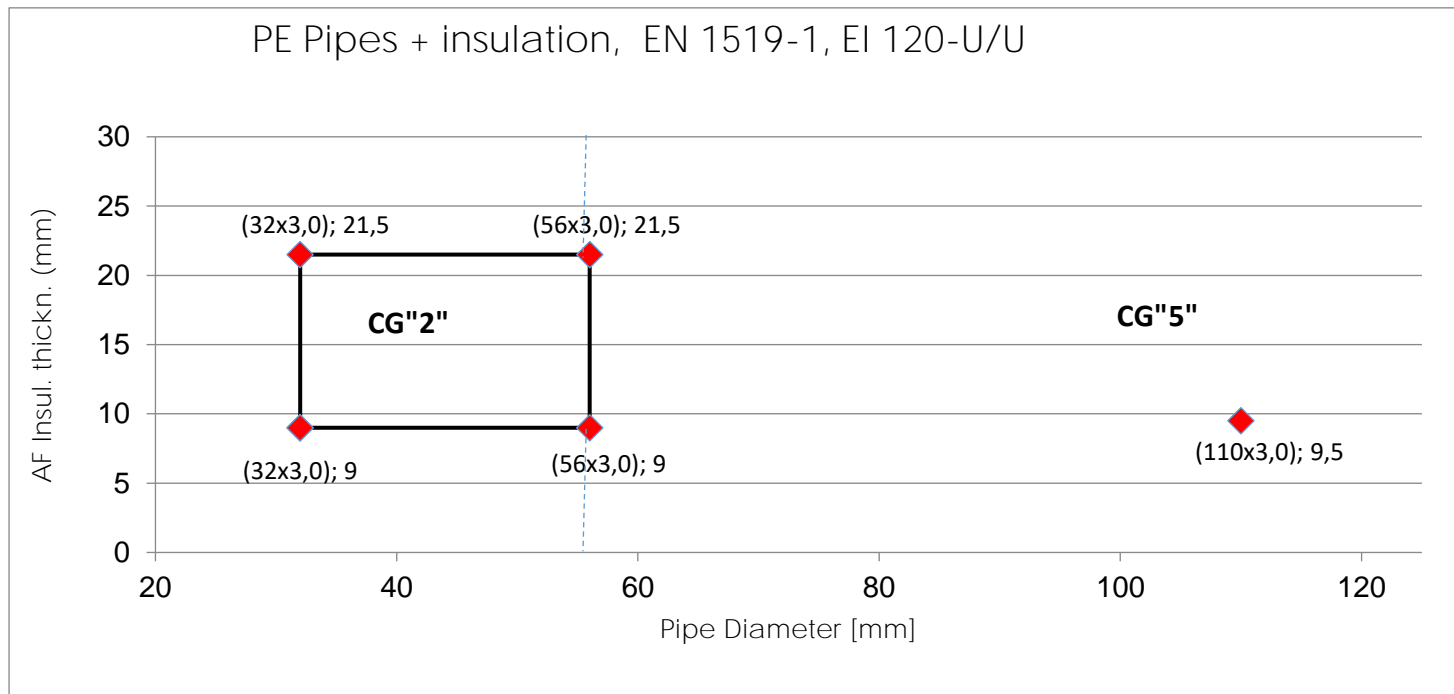

2.2.14.6.5 PE-pipes, Geberit Silent dB20 EI 90-U/U

PE-pipes, non-regulated, designation Geberit Silent dB20						
Layers	Pipe diameter Ø _{dc} (mm)	Pipe wall thickness t _c (mm)	Separation a1 (mm)	Separation a2 (mm)	Separation a3 (mm)	Classification
2	56	3,2	25	25	50	EI 90-U/U and E 120-U/U
3	>56 to 75	3,2 to 3,6	25	25	50	
4	>75 to 110	5,5 to 6,0	25	25	50	
6	>110 to 160	6,0 to 7,0	25	25	50	

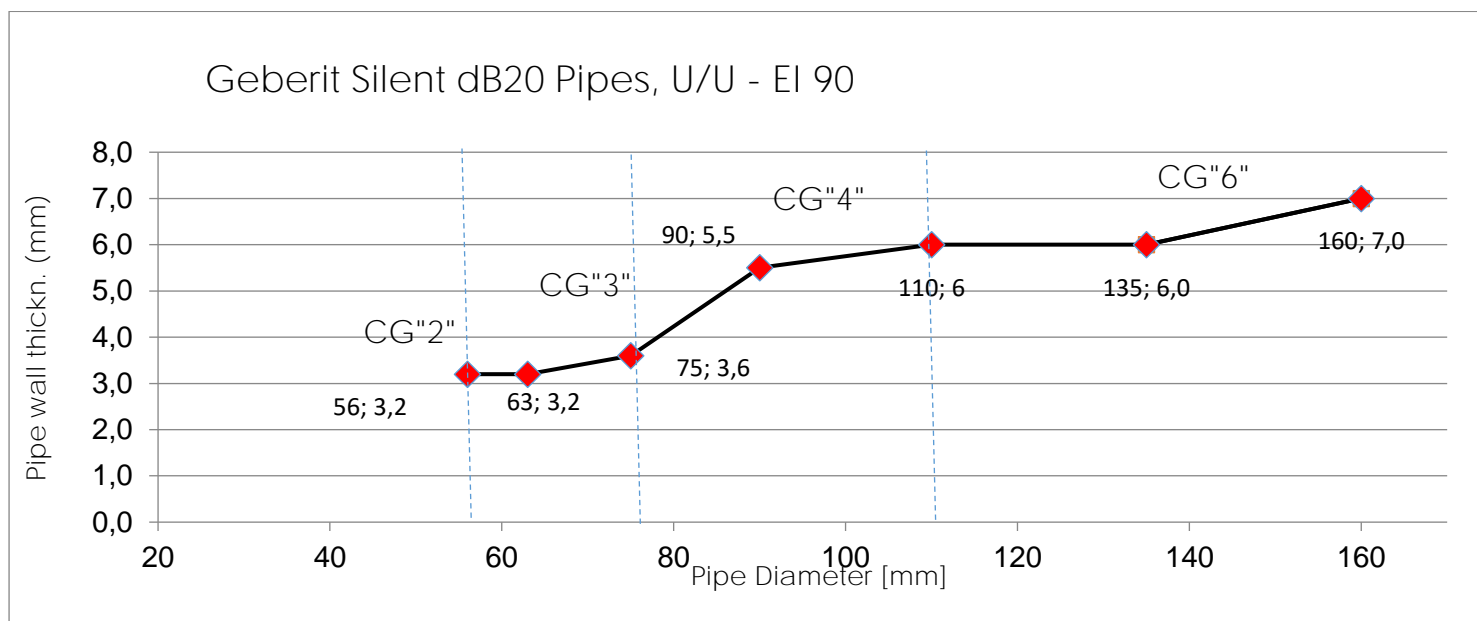

2.2.14.6.6 PE-pipes, Geberit Silent dB20 EI 120-U/U

PE-pipes, non-regulated, designation: Geberit Silent dB20						
Layers	Pipe diameter Ø dc (mm)	Pipe wall thickness tc (mm)	Separation a1 (mm)	Separation a2 (mm)	Separation a3 (mm)	Classification
2	56	3,2	50	50	100	EI 120-U/U; E 120-U/U
3	>56 to 75	3,2 to 3,6	173	50	100	
4	>75 to 110	5,5 to 6,0	142	154	100	
6	>110 to 135	6,0	25	25	25	

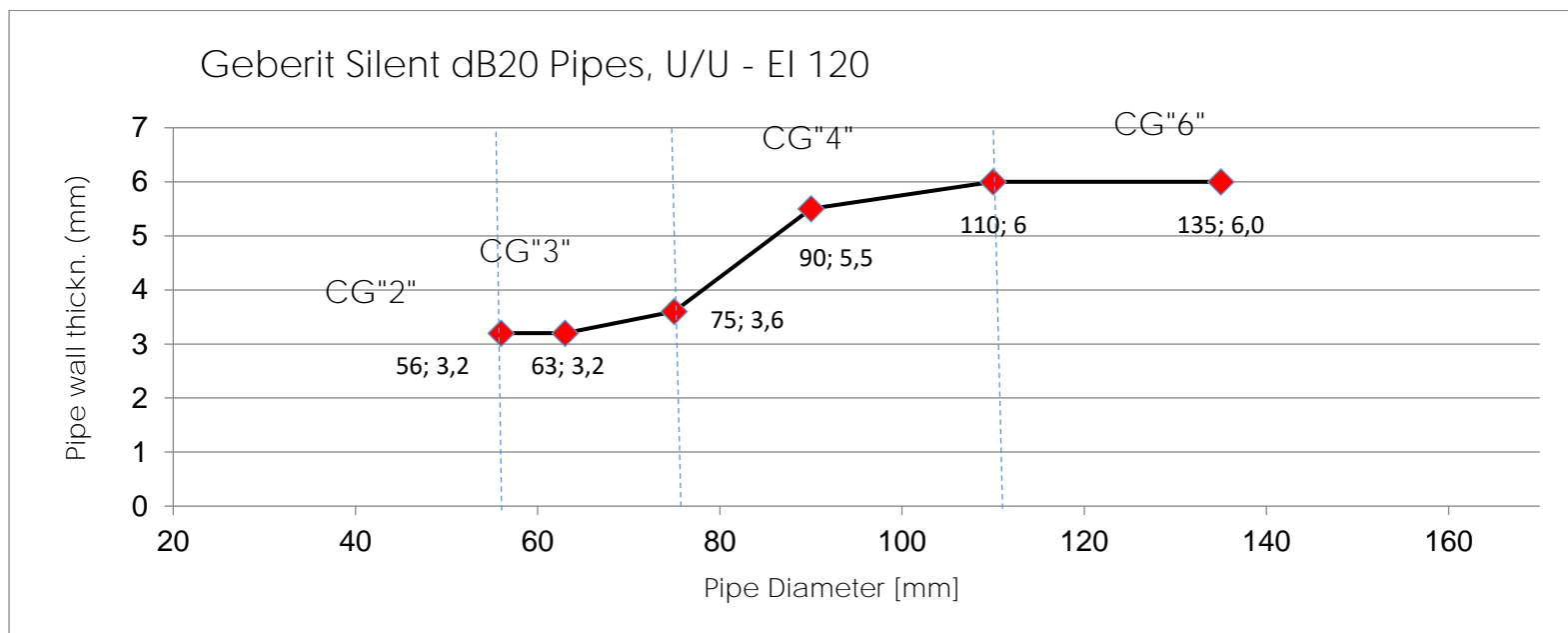

2.2.14.6.7 PE – pipes acc. EN 15494 EI 90-U/C

PE-pipes according EN 15494						
Layers	Pipe diameter Ø _{dc} (mm)	Pipe wall thickness t _c (mm)	Separation a1 (mm)	Separation a2 (mm)	Separation a3 (mm)	Classification
2	32 to 50	1,8 to 6,9	25	25	25	EI 90-U/C, E 120-U/C
3	> 50 (1,8 to 6,8) to 75 (1,9 to 6,8)		25	25	25	
4	> 75 (2,2 to 7,4) to 90 (2,2 to 7,4) to 125 (3,1 to 7,1)		25	25	25	
6	> 125 (3,5 to 9,1) to 140 (3,5 to 9,1) to 160 (4,0 to 9,1)		25	25	25	

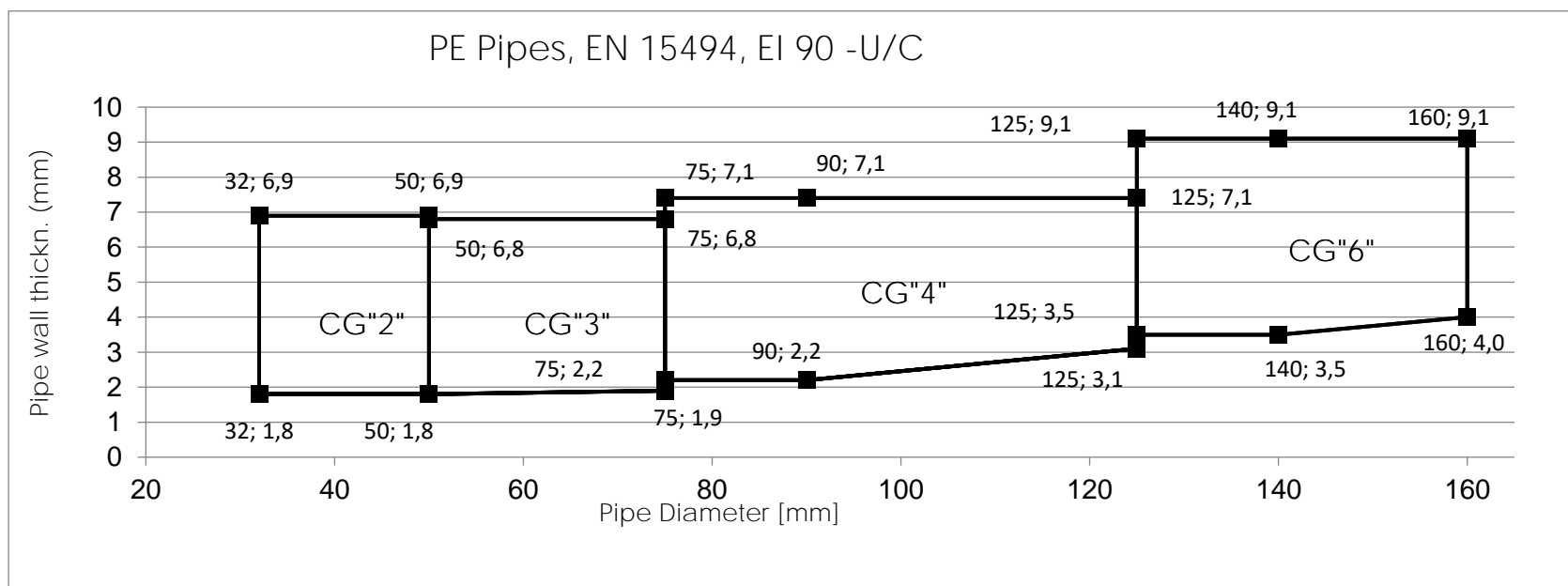

2.2.14.6.8 PE – pipes acc. EN 15494 EI 120-U/C

PE-pipes according EN 15494						
Layers	Pipe diameter Ø dc (mm)	Pipe wall thickness tc (mm)	Separation a1 (mm)	Separation a2 (mm)	Separation a3 (mm)	Classification
2	32 to 50	1,8 to 6,9	214	107	100	EI 120-U/C , E 120-U/C
3	> 50 (1,8 to 6,8) to 75 (1,9 to 6,8)		200	176	100	
4	> 75 (1,9 to 7,1) to 90 (2,2 to 7,1) to 125 (3,1 to 7,1)		108	50	100	
6	> 125 (3,5 to 9,1) to 140 (3,5 to 9,1) to > 160 (4,0 to 9,1)		66	50	100	

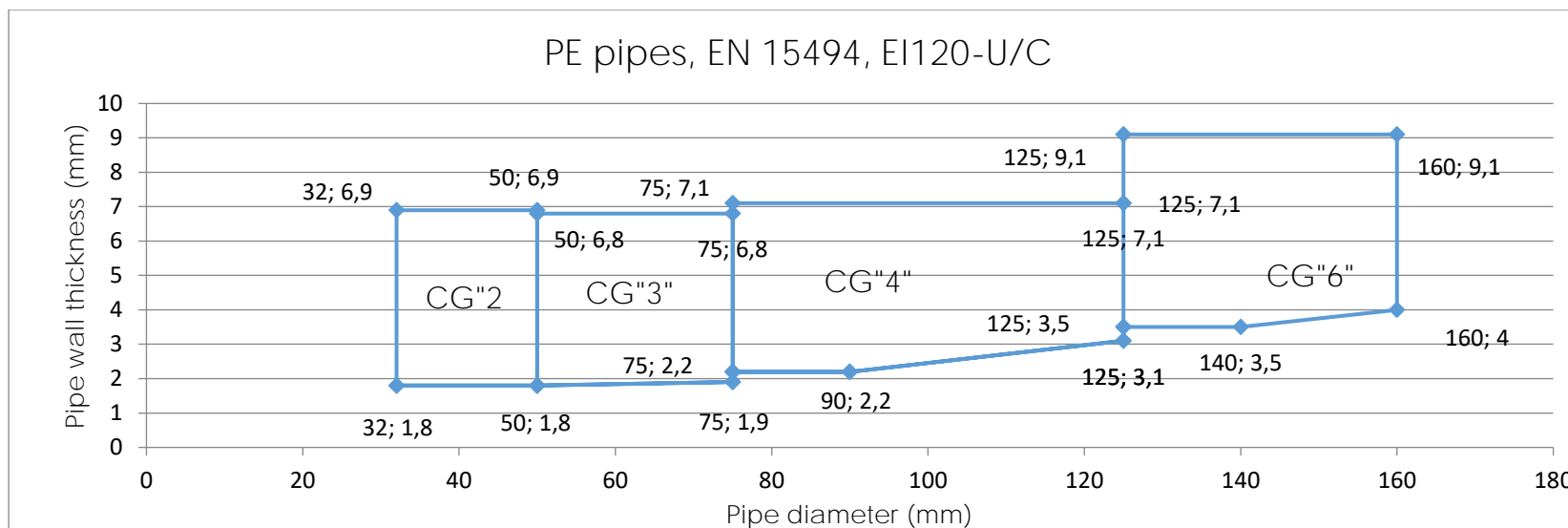

2.2.14.6.9 PP – pipes, non-regulated EI 90-U/U

PP – pipes, non-regulated , For pipe type/manufacturer refer to 2.1.6.						
Layers	Pipe diameter Ø dc (mm)	Pipe wall thickness tc (mm)	Separation a1 (mm)	Separation a2 (mm)	Separation a3 (mm)	Classification
2	> 32 (1,8 to 4,0) to 50 (1,8 to 4,0) 58 (4,0 to 4,0)		25	25	50	EI 90-U/U E 120 – U/U
3	50 (1,9 to 1,9) to 58 (1,9 to 4,0) to 63 (1,9 to 3,8) to 75 (1,9 to 3,8)		25	25	50	
4	> 75 (2,2 to 5,3) to 90 (2,2 to 5,3) to 125 (3,1 to 5,3)		25	25	50	
6	>125 (3,9 to 7,5) to 160 (3,9 to 7,5)		25	25	50	

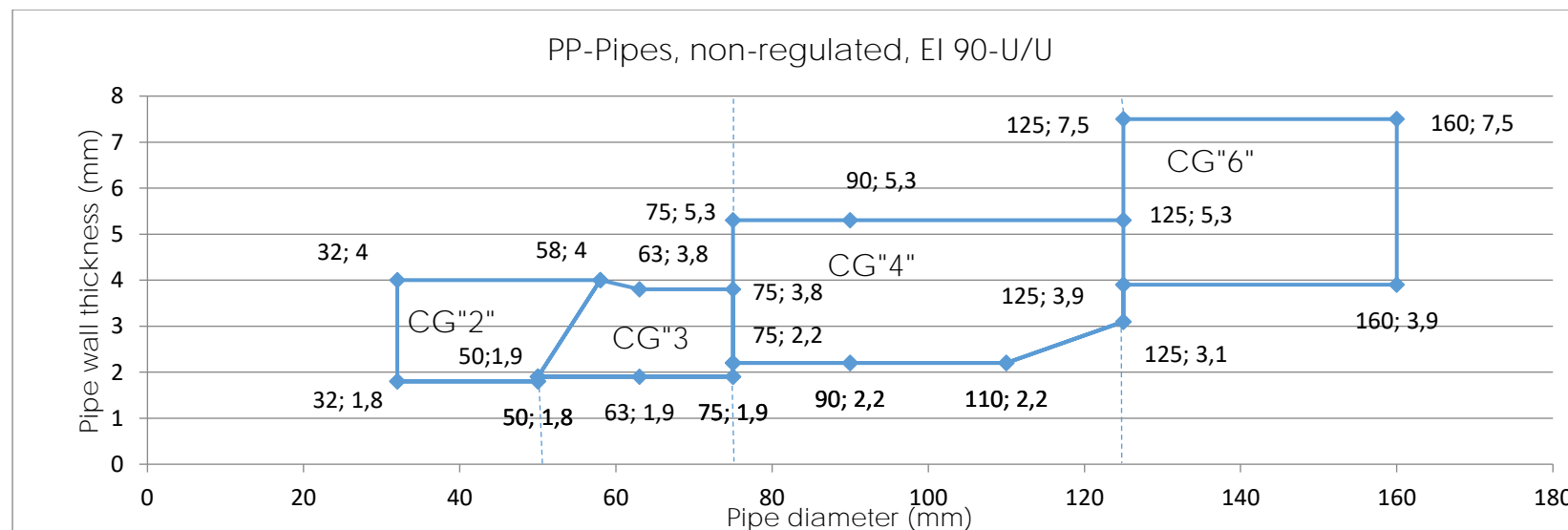

2.2.14.6.10 PP – pipes, non-regulated EI 120-U/U

PP – pipes, non-regulated , designation: Coes Blue Power, Coes PhoNo Fire, Geberit Silent PP, Marley Silent, Ostendorf Skolan dB, Pipelife Master 3, Poloplast Polokal NG, Poloplast Polokal 3S, Poloplast Polokal XS, Rehau Raupiano Plus, Kekelit PhonEX AS, Valsir Triplus, Valsir Silere, Wavin SiTech, Wavin AS						
Layers	Pipe diameter Ø dc (mm)	Pipe wall thickness tc (mm)	Separation a1 (mm)	Separation a2 (mm)	Separation a3 (mm)	Classification
2	32 (1,8 to 4,0) to 50 (1,8 to 4,0) to 58 (4,0 to 4,0)		191	50	130	EI 120-U/U, E 120-U/U
3	75	1,9	162	25	100	
4	> 75 (2,2 to 5,3) to 125 (3,1 to 5,3)		143	50	100	
6	160	3,9	160	60	20	

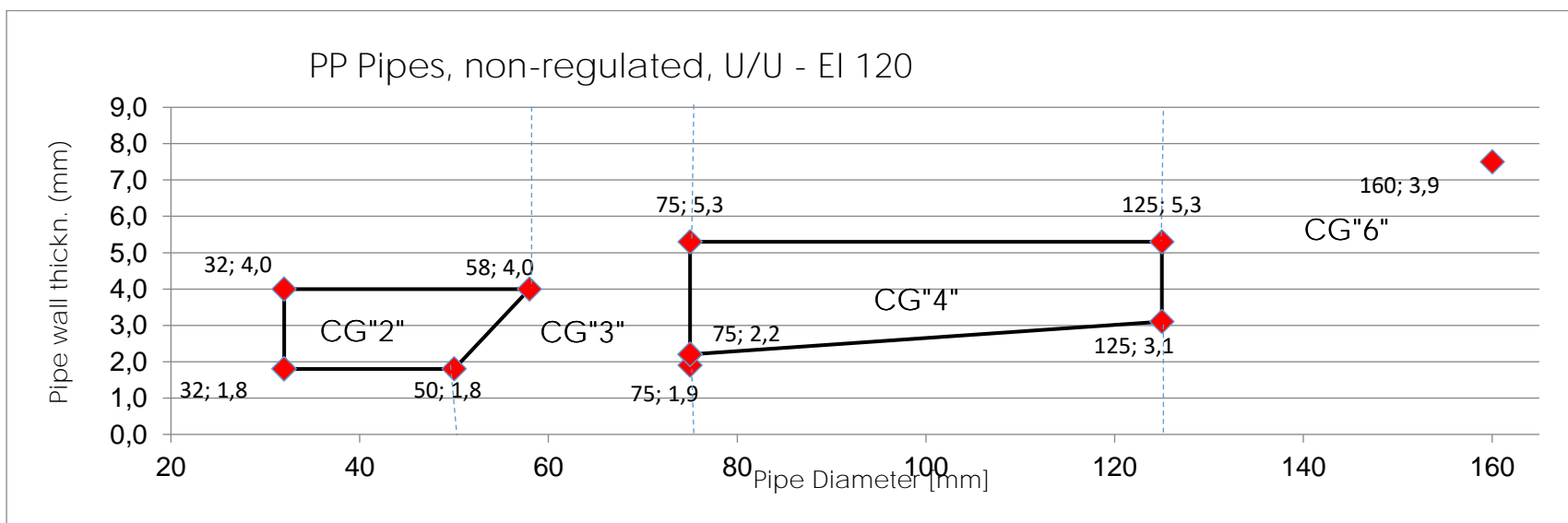

2.2.14.6.11 PVC-pipes according to EN 1452-1 - EI 90-U/U

PVC – pipes, according EN 1452-1 ,						
Layers	Pipe diameter Ø dc (mm)	Pipe wall thickness tc (mm)	Separation a1 (mm)	Separation a2 (mm)	Separation a3 (mm)	Classification
2	32 to 50	1,8 to 5,6	25	25	50	EI 90-U/U E 120-U/U
3	> 50 to 75	2,2 to 5,6	25	25	50	
4	> 75 to 90	1,8 to 8,1	25	25	50	
4	> 90 (1,8 to 8,1) to 110 (2,2 to 8,1)		25	25	50	
4	> 110 (2,2 to 8,1) to 125 (3,7 to 6,0)		25	25	50	
6	> 125 to 160	2,5 to 11,8	25	25	50	

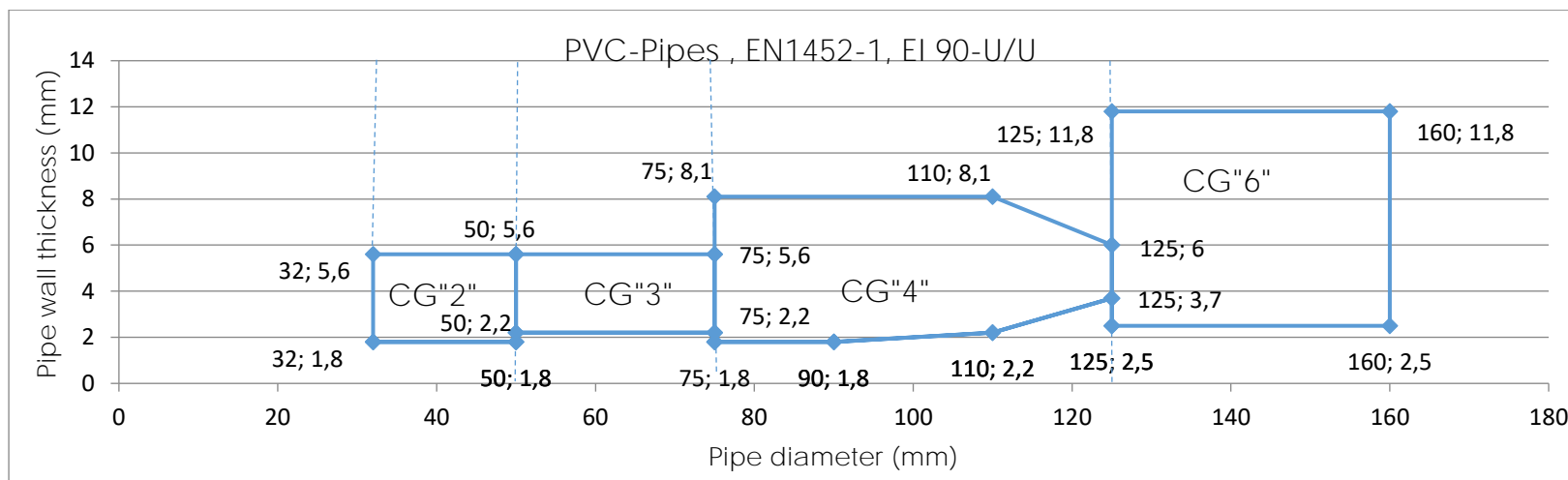

2.2.14.6.12 PVC-pipes according to EN 1452-1 - EI 120-U/U

For EI 120-U/U, PVC – pipes, according EN 1452-1 ,						
Layers	Pipe diameter Ø dc (mm)	Pipe wall thickness tc (mm)	Separation a1 (mm)	Separation a2 (mm)	Separation a3 (mm)	Classification
2	32 (1,8 to 5,6) to 50 (1,8 to 5,6)		115	107	100	EI 120-U/U
3	> 50 (1,8 to 5,6) to 75 (1,9 to 5,6)		150	174	100	
4	> 75 (2,2 to 6,0) to 110 (2,2 to 6,0) to 125 (3,7 to 6,0)		185	80	100	
6	> 125 (2,5 to 11,8) to 160 (2,5 to 11,8)		50	50	100	

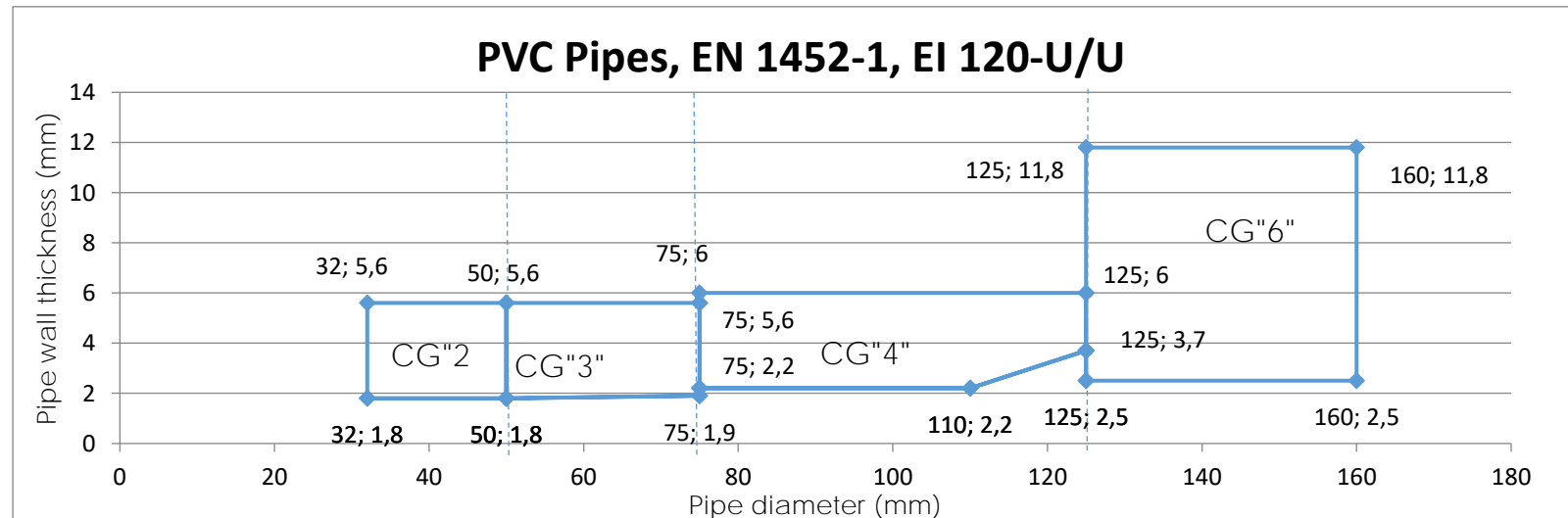

2.2.14.6.13 Geberit PushFit PB

	Material: PB (Polybuten) Seal design: ii) according 2.2.11.1 Approved pipe insulation material (CS): flexible elastomeric insulation see 1.2.12 table 4, distances: $S_8 \geq 100\text{mm}$, $S_6 \geq 50\text{mm}$ (see 2.2)						
Layers	Pipe diameter \varnothing dc (mm)	Pipe wall thickness t_c (mm)	Pipe insulation Material:	Pipe insulation thickness (mm)	Additional Protect Insulation Material:	Additional Protect Insulation thickness (mm)	Classification
3	20	2,0	Elastomer, see 1.2.12 table 4	8,5 to 25,0	none	0	EI 120-U/C
3	25	2,5	Elastomer, see 1.2.12 table 4	9,0 to 27,0	none	0	EI 120-U/C
	Approved pipe insulation material (LS, total length: $\geq 650\text{mm}$): PE hardcover Geberit for Geberit PushFit PB						
1	20	2,0	PE-foam	6	none	0	EI 120-U/C
1	25	2,5	PE-foam	6	none	0	EI 120-U/C

2.2.15 Aluminium composite pipes with elastomeric insulation, penetrating a CFS-CT double board seal, provided with Hilti firestop wrap CFS-W P and gap filler

2.2.15.1 Rehau Rautitan Stabil, penetrating CFS-CT, sealed with CFS-W P

Classification : EI 90-U/C, E120-U/C Material: PE-Xa/AL/PE-HD, seal type iii) according 2.2.11.1, Approved pipe insulation material: see 1.2.12 table 4							
Layers	Pipe diameter Ø dc (mm)	Pipe wall thickness tc (mm)	Pipe insulation thickness (mm)	Separation a1 (mm)	Separation a2 (mm)	Separation a3 (mm)	Classification
1	16	2,6	8,0 to 32,0	25	0	0	EI 90-U/C, E 120
1	20	2,9	8,5 to 33,5	25	0	0	
1	25	3,7	8,5 to 35,0	25	0	0	
1	32	4,7	9,0 to 35,0	25	0	0	
1	40	6,0	9,0 to 35,0	25	0	0	

Classification : EI 120-U/C, E 120-U/C Material: PE-Xb/AL/PE-HD, seal type iii) according 2.2.11.1, Approved pipe insulation material: see 1.2.12 table 4							
Layers	Pipe diameter Ø dc (mm)	Pipe wall thickness tc (mm)	Pipe insulation thickness (mm)	Separation a1 (mm)	Separation a2 (mm)	Separation a3 (mm)	Classification
1	16	2,6	8,0 to 32,0	213	50	50	EI 120-U/C, E 120-U/C
1	20	2,9	8,5 to 33,5	213	50	50	
1	25	3,7	8,5 to 35,0	213	50	50	
1	32	4,7	9,0 to 35,0	213	50	50	
1	40	6,0	9,0 to 35,0	213	50	50	

2.2.15.2 Uponor MLC, penetrating CFS-CT, sealed with CFS-W P

Classification : EI 90-U/C, E 120-U/C Material: PE-RT/AL/PE-RT, seal type iii) according 2.2.11.1, Approved pipe insulation material: see 1.2.12 table 4							
Layers	Pipe diameter Ø dc (mm)	Pipe wall thickness tc (mm)	Pipe insulation thickness (mm)	Separation a1 (mm)	Separation a2 (mm)	Separation a3 (mm)	Classification
1	16	2,0	8,0 to 32,0	25	0	0	EI 90-U/C, E 120-U/C
1	20	2,25	8,5 to 33,5	25	0	0	
1	25	2,5	8,5 to 35,0	25	0	0	
1	32	3,0	9,0 to 35,0	25	0	0	
2	50	4,5	9,0 to 38,0	25	0	0	
2	63	6,0	9,5 to 39,5	25	0	0	
2	75	7,5	9,5 to 40,5	25	0	0	
Classification : EI 120-U/C, E 120-U/C Material: PE-RT/AL/PE-RT, seal type iii) according 2.2.11.1, Approved pipe insulation material: see 1.2.12 table 4							
Layers	Pipe diameter Ø dc (mm)	Pipe wall thickness tc (mm)	Pipe insulation thickness (mm)	Separation a1 (mm)	Separation a2 (mm)	Separation a3 (mm)	Classification
1	16	2,0	8,0 to 32,0	213	50	0	EI 120-U/C, E 120-U/C
1	20	2,25	8,5 to 33,5	213	50	0	
1	25	2,5	8,5 to 35,0	213	50	0	
1	32	3,0	9,0 to 35,0	213	50	0	
2	50	4,5	9,0 to 38,0	109	0	0	
2	63	6,0	9,5 to 39,5	109	0	0	
2	75	7,5	9,5 to 40,5	109	0	0	

2.2.15.3 Kekelit Kelox, penetrating CFS-CT, sealed with CFS-W P

Material: PE-X/AL/PE-X, seal type iii) according 2.2.11.1 Approved pipe insulation material: see 1.2.12 table 4							
Layers	Pipe diameter Ø dc (mm)	Pipe wall thickness tc (mm)	Pipe insulation thickness (mm)	Separation a1 (mm)	Separation a2 (mm)	Separation a3 (mm)	Classification
1	16	2,0	8,0 to 32,0	25	0	0	EI 90-U/C, E 120-U/C
1	20	2,25	8,5 to 33,5	25	0	0	
1	25	2,5	8,5 to 35,0	25	0	0	
1	32	3,0	9,0 to 35,0	25	0	0	
2	< 32 to < 75	> 3,0 to > 7,5	9,0 to 35,0	25	0	0	
2	75	7,5	9,5 to 40,5	25	0	0	

Material: PE-X/AL/PE-X, seal type iii) according 2.2.11.1 Approved pipe insulation material: see 1.2.12 table 4							
Layers	Pipe diameter Ø dc (mm)	Pipe wall thickness tc (mm)	Pipe insulation thickness (mm)	Separation a1 (mm)	Separation a2 (mm)	Separation a3 (mm)	Classification
1	16	2,0	8,0 to 32,0	149	25	25	EI 120-U/C, E 120-U/C
1	20	2,25	8,5 to 33,5	167	25	50	
1	25	2,5	8,5 to 35,0	167	25	50	
1	32	3,0	9,0 to 35,0	167	25	50	
2	> 32 to < 75	> 3,0 to < 7,5	9,0 to 35,0	25	25	0	
2	75	7,5	9,5 to 40,5	25	25	0	

2.2.15.4 Geberit Mepla, penetrating CFS-CT, sealed with CFS-W P

Material: PE-Xb/AL/PE-HD, seal type iii) according 2.2.11.1 Approved pipe insulation material: see Annex 1 - 1.2.12 table 4							
Layers	Pipe diameter Ø dc (mm)	Pipe wall thickness tc (mm)	Pipe insulation thickness (mm)	Separation a1 (mm)	Separation a2 (mm)	Separation a3 (mm)	Classification
1	16	2,3	8,0 to 32,0	25	0	0	EI 90-U/C, E 120-U/C
1	20	2,5	8,5 to 33,5	25	0	0	
1	26	3,0	8,5 to 35,0	25	0	0	
1	32	3,0	9,0 to 35,0	25	0	0	
2	> 32 to < 75	> 3,0 to < 7,5	9,0 to 36,0	25	0	0	
2	75	7,5	9,5 to 40,5	25	0	0	

Material: PE-Xb/AL/PE-HD, seal type iii) according 2.2.11.1 Approved pipe insulation material: see Annex 1 - 1.2.12 table 4							
Layers	Pipe diameter Ø dc (mm)	Pipe wall thickness tc (mm)	Pipe insulation thickness (mm)	Separation a1 (mm)	Separation a2 (mm)	Separation a3 (mm)	Classification
1	16	2,3	8,0 to 32,0	212	107	50	EI 120-U/C, E 120-U/C
1	20	2,5	8,5 to 33,5	212	107	50	
1	26	3,0	8,5 to 35,0	212	107	50	
1	32	3,0	9,0 to 35,0	140	103	50	

2.2.15.5 Viegas Sanfix Fosta and Viegas Raxofix, penetrating CFS-CT, sealed with CFS-W P

<p>Material: PE-Xc/AL/PE-Xc, seal type iii) according 2.2.11.1</p> <p>Approved pipe insulation material (CS): flexible elastomeric insulation see Annex 1 - 1.2.12 table 4, distances: $S_8 \geq 100\text{mm}$, $S_6 \geq 50\text{mm}$ (see 2.6)</p> <p>Additional Protect Insulation (LI, 250mm): flexible elastomeric insulation see Annex 1 - 1.2.12 table 4 or mineral wool see AP7</p>							
Layers	Pipe diameter \varnothing dc (mm)	Pipe wall thickness t_c (mm)	Pipe insulation Material:	Pipe insulation thickness (mm)	Additional Protect Insulation Material:	Additional Protect Insulation thickness (mm)	Classification
1	16	2,2	Elastomer, see Annex 1 - 1.2.12 table 4	8,0 to 32,0	none	0	EI 120-U/C
1	20	2,8	Elastomer, see Annex 1 - 1.2.12 table 4	8,5 to 33,5	none	0	EI 120-U/C
1	25	2,7	Elastomer, see Annex 1 - 1.2.12 table 4	8,5 to 35,0	none	0	EI 120-U/C
1	32	3,2	Elastomer, see Annex 1 - 1.2.12 table 4	9,0 to 35,0	none	0	EI 120-U/C
1	40	3,5	Elastomer, see Annex 1 - 1.2.12 table 4	9,0 to 36,5	none	0	EI 120-U/C
2	50	4,0	Elastomer, see Annex 1 - 1.2.12 table 4	9,0 to 38,0	none	0	EI 60-U/C
2	63	4,5	Elastomer, see Annex 1 - 1.2.12 table 4	9,5 to 39,5	none	0	EI 60-U/C
2	63	4,5	Elastomer, see Annex 1 - 1.2.12 table 4	9,5 to 39,5	Elastomer, see Annex 1 - 1.2.12 table 4	19	EI 120-U/C
2	63	4,5	Elastomer, see Annex 1 - 1.2.12 table 4	9,5 to 39,5	Mineral wool	30	EI 120-U/C

<p>Viega Sanfix Fosta and Raxofix pipes: Material: PE-Xc/AL/PE-Xc, seal type iii) according 2.2.11.1 Approved pipe insulation material (CS): Mineral wool, see 2.1.4 distances: $S_8 \geq 100\text{mm}$, $S_6 \geq 50\text{mm}$ (see 2.6)</p>							
Layers	Pipe diameter Ø dc (mm)	Pipe wall thickness t_c (mm)	Pipe insulation Material:	Pipe insulation thickness (mm)	Additional Protect Insulation Material:	Additional Protect Insulation thickness (mm)	Classification
0	16	2,2	Mineral wool, see 2.1.4	20 to 40	none	0	EI 120-U/C
0	20	2,8	Mineral wool, see 2.1.4	20 to 50	none	0	EI 120-U/C
0	25	2,7	Mineral wool, see 2.1.4	20 to 60	none	0	EI 120-U/C
0	32	3,2	Mineral wool, see 2.1.4	20 to 60	none	0	EI 120-U/C
0	40	3,5	Mineral wool, see 2.1.4	20 to 60	none	0	EI 120-U/C
0	50	4,0	Mineral wool, see 2.1.4	20 to 60	none	0	EI 120-U/C
0	63	4,5	Mineral wool, see 2.1.4	20 to 60	none	0	EI 120-U/C

2.2.15.6 Geberit PushFit ML, penetrating CFS-CT, sealed with CFS-W P

Material: PE-HD/AL/PE-HD, seal type iii) according 2.2.11.1 Approved pipe insulation material (CS): flexible elastomeric insulation see Annex 1 - 1.2.12 table 4, distances: $S_8 \geq 100\text{mm}$, $S_6 \geq 50\text{mm}$ (see 2.2)							
Layers	Pipe diameter \varnothing dc (mm)	Pipe wall thickness tc (mm)	Pipe insulation Material:	Pipe insulation thickness (mm)	Additional Protect Insulation Material:	Additional Protect Insulation thickness (mm)	Classification
1	20	2,0	Elastomer, see Annex 1 - 1.2.12 table 4	8,5 to 33,5	none	0	EI 120-U/C
1	25	2,5	Elastomer, see Annex 1 - 1.2.12 table 4	8,5 to 35,0	none	0	EI 120-U/C
0	20	2,0	Mineral wool, see Annex 1 - 1.2.12 table 3	20 to 40	none	0	EI 120-U/C
0	25	2,5	Mineral wool, see Annex 1 - 1.2.12 table 3	20 to 60	none	0	EI 120-U/C
Approved pipe insulation material (LS, total length: $\geq 600\text{mm}$): flexible PE isolation							
1	20	2,0	PE-foam	6	none	0	EI 120-U/C
1	25	2,5	PE-foam	6	none	0	EI 120-U/C

2.2.16 Metal pipes with elastomeric insulation, penetrating a CFS-CT double board seal, provided with Hilti firestop wrap CFS-W P and gap filler

2.2.16.1 Isolated copper pipes, penetrating CFS-CT, sealed with CFS-W P

	Material: copper, stainless steel, steel, iron, seal type iv) according 2.2.11.1 Approved pipe insulation material: see Annex 1 - 1.2.12 table 4						
Layers	Pipe diameter Ø _{dc} (mm)	Pipe wall thickness t _c (mm)	Pipe insulation thickness (mm)	Separation a1 (mm)	Separation a2 (mm)	Separation a3 (mm)	Classification
1	10	1,0 to 1,2	7,5 to 32,0	25	25	50	EI 90-C/U, E 120-C/U
1	42	1,0 to 1,2	9,0 to 36,5	25	25	50	

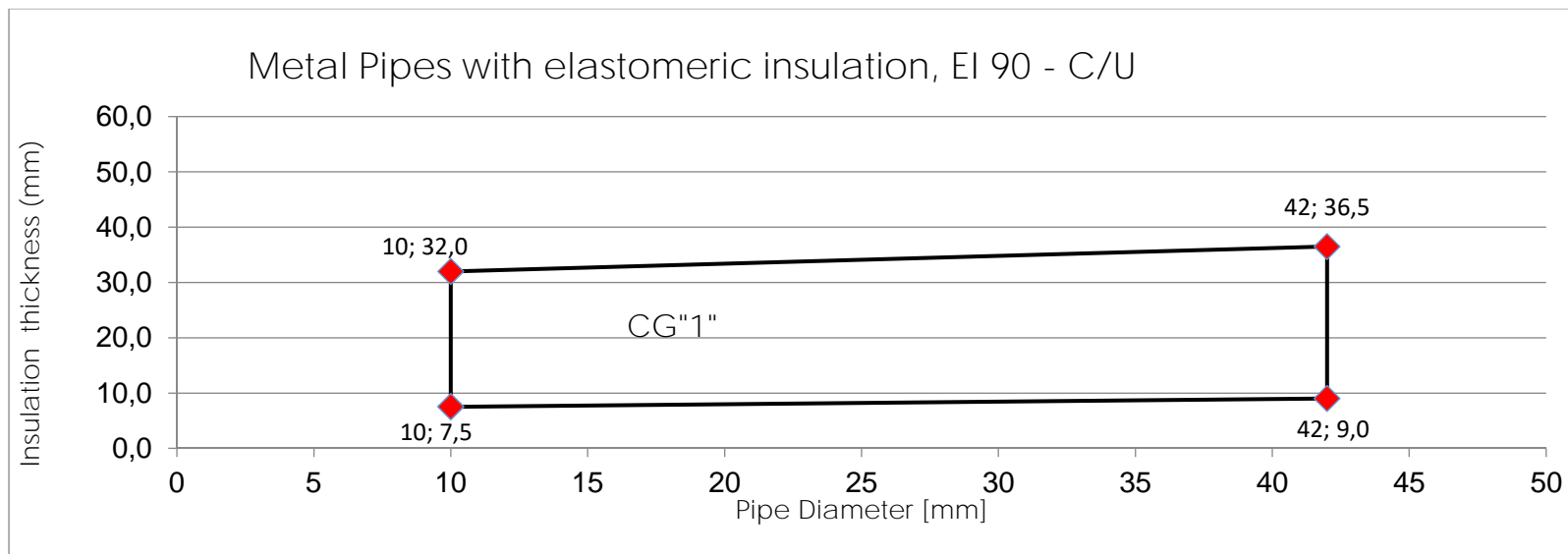

Material: copper, stainless steel, steel, iron, seal type iv) according 2.2.11.1							
Approved pipe insulation material: see Annex 1 - 1.2.12 table 4							
Layers	Pipe diameter Ø _{dc} (mm)	Pipe wall thickness t _c (mm)	Pipe insulation thickness (mm)	Separation a1 (mm)	Separation a2 (mm)	Separation a3 (mm)	Classification
1	10	1,0	7,5 to 32,0	25	25	50	EI 120-C/U, E 120-C/U
1	28	1,0	8,5 to 35,0	25	25	50	

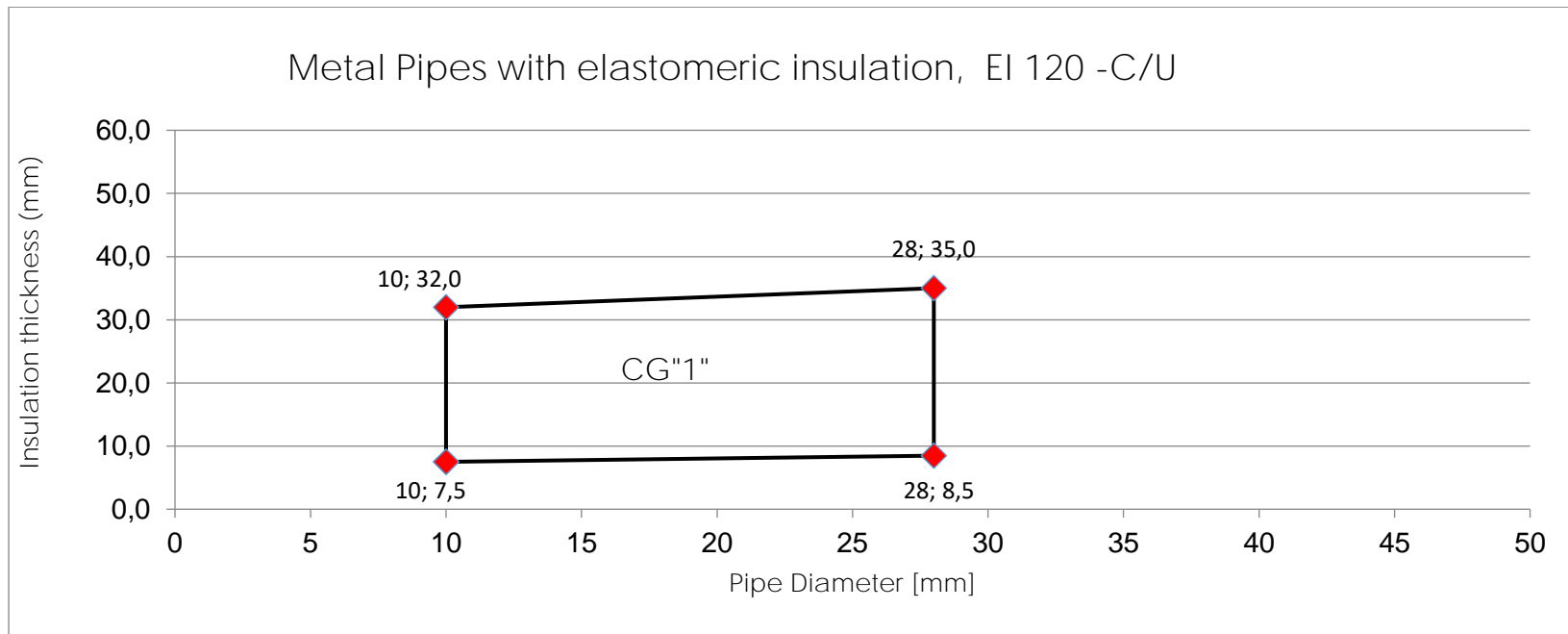

2.2.16.2 Isolated steel pipes, penetrating CFS-CT, sealed with CFS-W P

Material: stainless steel, steel, iron; seal type v) according 2.2.11.1 Approved pipe insulation material: see Annex 1 - 1.2.12 table 4							
Layers	Pipe diameter Ø dc (mm)	Pipe wall thickness tc (mm)	Pipe insulation thickness (mm)	Separation a1 (mm)	Separation a2 (mm)	Separation a3 (mm)	Classification
1	10 to 28	1,0	7,5/8,5 to 32,0/35,0	25	25	50	EI 90-C/U, E 120-C/U
2	> 28 to 114	3,4	8,5/9,5 to 35,0/43,0	25	25	50	
3	> 114 to 219	6,3	9,5/19,0 to 43,0/50,0	25	25	50	

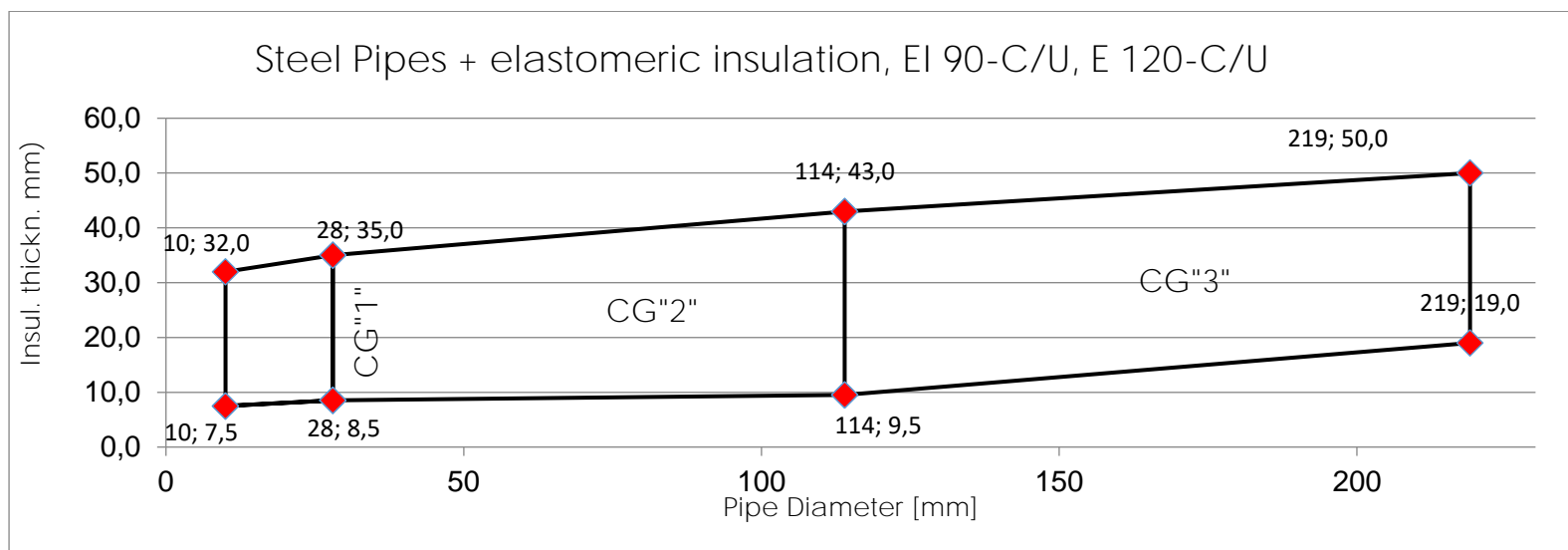

Material: stainless steel, steel, iron; seal type v) according 2.2.11.1							
Approved pipe insulation material: see Annex 1 - 1.2.12 table 4							
Layers	Pipe diameter Ø _{dc} (mm)	Pipe wall thickness t _c (mm)	Pipe insulation thickness (mm)	Separation a1 (mm)	Separation a2 (mm)	Separation a3 (mm)	Classification
1	10	1,0	7,5 to 32,0	25	25	50	EI 120-C/U, E 120-C/U
1	28	1,0	8,5 to 35,0	25	25	50	

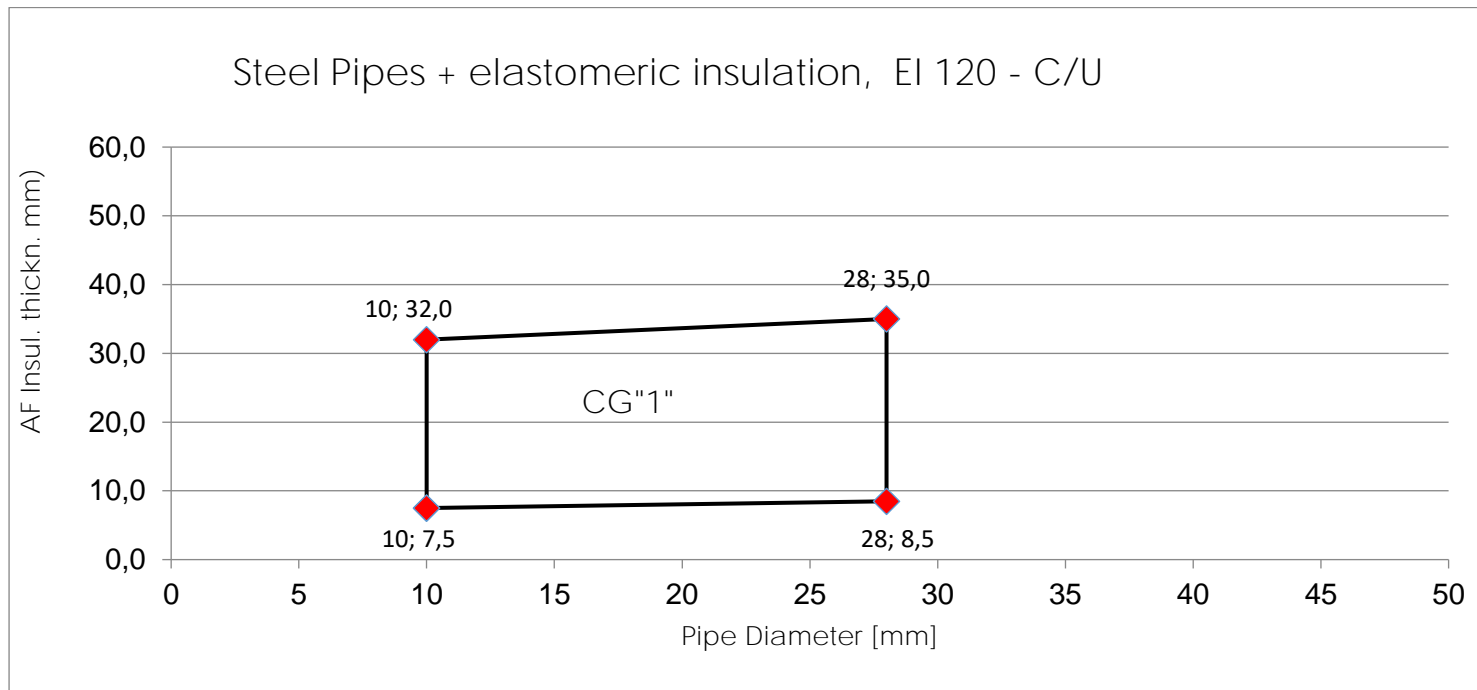

Material: stainless steel, steel, iron; seal type v) according 2.2.11.1

Approved flexible, elastomeric pipe insulation (CS) and additional pipe insulation (LI) (AP8 – refer to 2.1.4): for material see Annex 1 - 1.2.12 table 4

Pipe designation: Geberit Mapress, distances: $S_8 \geq 100\text{mm}$, $S_6 \geq 50\text{mm}$ (see 2.2)

Layers	Pipe diameter \varnothing dc (mm)	Pipe wall thickness tc (mm)	Pipe insulation thickness (mm)	Additional Pipe Insulation Type	Additional Pipe Insulation Thickness (mm)	Additional Pipe Insulation Length(mm)	Classification
2	66,7	1,5	17,5 to 40,0	none	0	n.a.	EI 90-C/U
2	66,7	1,5	9,5 to 40,0	Elastomer see 1.2.12 table 4	19	250	EI 120-C/U
2	66,7	1,5	9,5 to 40,0	Mineral wool, see 2.1.4	30	250	EI 120-C/U
2	108	2,0	18,0 – 42,5	none	0	n.a.	EI 30-C/U
2	108	2,0	18,0 – 42,5	Elastomer see 1.2.12 table 4	19	250	EI 60-C/U
2	108	2,0	18,0 – 42,5	Mineral wool, see 2.1.4	30	250	EI 120-C/U

2.3 Flexible walls according to 2.1 a) and rigid walls according to 2.1 b), minimum thickness 135 mm

Penetration seal:

Two 50 mm Hilti Firestop Boards CFS-CT B 1S⁸ (A₁) or mineral wool boards according to Table 1 coated with Hilti Firestop Coating CFS-CT (A₁), dry thickness of coating 0.7 mm on the outer side⁹, all cut edges of boards sealed with Hilti Firestop Acrylic Sealant CFS-S ACR, remaining gaps around cables / cable supports (trays, ladders etc.) and other services filled with Hilti Firestop Acrylic Sealant CFS-S ACR.

The boards have to be positioned flush to the surface of the building element on each side of the wall.

Maximum distance for 1st service support: 250 mm.

Maximum seal size: 1200 x 1200 mm (width x height).

Minimum distances in mm (for illustration see Annex 2.2):

$s_6 = 0$ (distance between metal pipes and seal edge)

$s_8 = 0$ (distance between metal pipes)

$s_9 = 15$ (distance between plastic pipes/pipe closure devices and seal edge)

$s_{11} = 0$ (distance between plastic pipes/pipe closure devices)

$s_{12} = 0$ (distance between metal pipes and plastic pipes/pipe closure devices)

$s_{13} = 96$ (distance between cables/cable supports and metal pipes)

$s_{14} = 69$ (distance between cables/cable supports and plastic pipes/pipe closure devices)

Penetrating services (single, multiple or mixed):

In addition to the services referred to in Annex 2.2 the following services with the classifications given below are covered:

2.3.1 Metal pipes

2.3.1.1 Metal pipes with mineral wool insulation according to Table 3

Construction details: see Annex 2.2.5.1

2.3.1.1.1 Steel pipes with mineral wool insulation according to Table 3

Steel pipes (C) with continued insulation (D) – interrupted – C/U

Pipe diameter (d_c) [mm]	Pipe wall thickness (t_c) [mm]	Insulation thickness (t_D) [mm]	Classification
32 -168.3	2.6/4.0 - 14.2 ¹⁰	≥ 30	EI 120-C/U

Steel pipes (C) with local insulation (D) – interrupted – C/U				
Pipe		Insulation		Classification
diameter (d _c) [mm]	wall thickness (t _c) [mm]	thickness (t _D) [mm]	length (L _D) [mm]	
32	2.6 - 14.2 ¹⁰	30	≥ 500	EI 120-C/U
32 -168.3	2.6/4.0 - 14.2 ¹⁰	30	≥ 800	EI 120-C/U
168.3	4.0 - 14.2	30 – 40	≥ 1000	EI 120-C/U
The field of application given above for steel pipes is also valid for other metal pipes with lower heat conductivity than unalloyed steel and a melting point of minimum 1050°C, e.g. . low alloyed steel, cast iron, stainless steels, Ni alloys (NiCu, NiCr and NiMo alloys)				
2.3.1.1.2 Copper pipes with mineral wool insulation according to Table 3				
Copper pipes (C) with continued insulation (D) – sustained				
Pipe diameter (d _c) [mm]	Pipe wall thickness (t _c) [mm]	Insulation thickness (t _D) [mm]		Classification
88.9	1.8 - 14.2	≥ 40		EI 120-C/U
Copper pipes (C) with local insulation (D) – sustained				
Pipe		Insulation		Classification
diameter (d _c) [mm]	wall thickness (t _c) [mm]	thickness (t _D) [mm]	length (L _D) [mm]	
88.9	1.8 - 14.2	40	≥ 800	EI 120-C/U
The field of application given above for copper pipes is also valid for other metal pipes with lower heat conductivity than copper and a melting point of minimum 1100°C, e.g. unalloyed steel, low alloyed steel, cast iron, stainless steels, Ni alloys (NiCu, NiCr and NiMo alloys) and Ni.				

2.3.2 Plastic pipes with Hilti Firestop Collar CFS-C

Construction details: see Annex 2.2.7

2.3.2.1 PVC-U pipes (C) according to EN ISO 1452-2, EN ISO 15493, DIN 8061/8062 – U/C

Pipe diameter (d _c) [mm]	Pipe wall thickness t _c [mm]	Collar size (A ₃)	No. of hooks	Classification
90	4.5	CFS-C 90/3"	3	EI 120-U/C

The results are also valid for PVC-U pipes according EN 1329-1¹⁶ and EN 1453-1¹⁷ as well as PVC-C pipes according 1566-1**2.3.2.2 PE pipes (C) according to EN ISO 15494, DIN 8074/8075**

Pipe diameter (d _c) [mm]	Pipe wall thickness t _c [mm]	Collar size (A ₃)	No. of hooks	Classification
90	2.2 - 8.2	CFS-C 90/3"	3	EI 120-U/C

2.4 Rigid walls according to 2.1 c), minimum thickness 150 mm

Penetration seal:

Two 50 mm Hilti Firestop Boards CFS-CT B 1S⁸ (A₁) or mineral wool boards according to Table 1 coated with Hilti Firestop Coating CFS-CT (A₁), dry thickness of coating 0.7 mm on the outer side⁹, all cut edges of boards sealed with Hilti Firestop Acrylic Sealant CFS-S ACR, remaining gaps around cables / cable supports (trays, ladders etc.) and other services filled with Hilti Firestop Acrylic Sealant CFS-S ACR.

The boards have to be positioned flush to the surface of the building element on each side of the wall.

Maximum distance for 1st service support: 275 mm.

Maximum seal size: 1200 x 1200 mm (width x height).

Minimum distances in mm (for illustration see Annex 2.2):

- s₁ = 0 (distance between cables/cable supports and seal edge)
- s₂ = 0 (distance between cable supports)
- s₃ = 45 (distance between cables and upper seal edge)
- s₄ = 0 (distance between cable supports and bottom seal edge)
- s₅ = 50 (distance between cables and cable support above)
- s₆ = 30 (distance between metal pipes and seal edge)
- s₇ = 3 (distance between metal pipes and upper seal edge)
- s₈ = 0 (distance between metal pipes)
- s₉ = 55 (distance between plastic pipes/pipe closure devices and seal edge)
- s₁₀ = 17 (distance between plastic pipes/pipe closure devices and upper seal edge)
- s₁₁ = 0 (distance between plastic pipes/pipe closure devices)
- s₁₂ = 68 (distance between metal pipes and plastic pipes/pipe closure devices)
- s₁₃ = 76 (distance between cables/cable supports and metal pipes)
- s₁₄ = 45 (distance between cables/cable supports and plastic pipes/pipe closure devices)

Penetrating services (single, multiple or mixed):

In addition to the services referred to in Annex 2.2 and Annex 2.3 the following services with the classifications given below are covered:

2.4.1 Cables	
Construction details: see drawings in Annex 2.2.2;	Classification
Additional protection according to 1.2.	AP ₁
All sheathed cable types currently and commonly used in building practice in Europe (e.g. power, control, signal, telecommunication, data, optical fibre cables, with or without cable supports, with a diameter of : maximum Ø 80 mm	EI 60
Non-sheathed cables (wires) currently and commonly used in building practice in Europe, with or without cable supports, with a diameter of : maximum Ø 17 mm	EI 90
Tied cable bundle, maximum diameter of single cable 21 mm, with or without cable supports. Maximum Ø 100 mm	EI 60

2.4.2 Small conduits and tubes	
Construction details: see drawings in Annex 2.2.2;	Classification
additional protection according to 1.2.	AP ₁
Ø ≤ 16 mm, wall thickness ≥ 1 mm, arranged linear, with or without cables, with or without cable supports	
Plastic conduits and tubes	EI 120-U/C
Steel conduits and tubes	EI 120-C/U

2.4.3 Metal pipes with mineral wool insulation according to Table 3			
Construction details: see Annex 2.2.5.1			
2.4.3.1 Steel pipes with mineral wool insulation according to Table 3			
Steel pipes (C) with continued insulation (D) – interrupted – C/U			
Pipe diameter (d _c) [mm]	Pipe wall thickness (t _c) [mm]	Insulation thickness (t _D) [mm]	Classification
32	4.0 - 14.2 ¹⁰	≥ 20	EI 120-C/U
32 - 114.3	3.6 - 14.2 ¹⁰	≥ 30	EI 120-C/U

Steel pipes (C) with local insulation (D) – interrupted – C/U				
Pipe		Insulation		Classification
diameter (d _c) [mm]	wall thickness (t _c) [mm]	thickness (t _D) [mm]	length (L _D) [mm]	
32	4.0 - 14.2 ¹⁰	20	≥ 500	EI 120-C/U
114.3	3.6 - 14.2	30	≥ 500	EI 120-C/U

The field of application given above for steel pipes is also valid for other metal pipes with lower heat conductivity than unalloyed steel and a melting point of minimum 1050°C, e.g. low alloyed steel, cast iron, stainless steels, Ni alloys (NiCu, NiCr and NiMo alloys)

2.4.3.2 Copper pipes with mineral wool insulation according to Table 3

Copper pipes (C) with continued insulation (D) – sustained – C/U

Pipe diameter (d _c) [mm]	Pipe wall thickness (t _c) [mm]	Insulation thickness (t _D) [mm]	Classification
42	1.5 - 14.2 ¹⁰	≥ 20	EI 120-C/U

Copper pipes (C) with local insulation (D) – sustained – C/U

Pipe		Insulation		Classification
diameter (d _c) [mm]	wall thickness (t _c) [mm]	thickness (t _D) [mm]	length (L _D) [mm]	
42	1.5 - 14.2 ¹⁰	40	≥ 500	EI 120-C/U

The field of application given above for copper pipes is also valid for other metal pipes with lower heat conductivity than copper and a melting point of minimum 1100°C, e.g. unalloyed steel, low alloyed steel, cast iron, stainless steels, Ni alloys (NiCu, NiCr and NiMo alloys) and Ni.

2.4.4 Plastic pipes with Hilti Firestop Collar CFS-C

Construction details: see Annex 2.2.7

PVC-U pipes (C) according to EN ISO 1452-2, EN ISO 15493, DIN 8061/8062 – U/C

Pipe diameter (d _c) [mm]	Pipe wall thickness t _c [mm]	Collar size (A ₃)	No. of hooks	Classification
32	1.9	CFS-C 50/1.5"	2	EI 120-U/C
110	2.2 – 8.2	CFS-C 110/4"	4	EI 120-U/C

The results are also valid for PVC-U pipes according EN 1329-1¹⁶ and EN 1453-1¹⁷ as well as PVC-pipes according EN 1566-1

2.5 Rigid walls according to 2.2 d), minimum thickness 150 mm

Penetration seal:

Two 50 mm Hilti Firestop Boards CFS-CT B 1S⁸ (A₁) or mineral wool boards according to Table 1 coated with Hilti Firestop Coating CFS-CT (A₁), dry thickness of coating 0.7 mm on the outer side⁹, all cut edges of boards sealed with Hilti Firestop Acrylic Sealant CFS-S ACR, remaining gaps around cables / cable supports (trays, ladders etc.) and other services filled with Hilti Firestop Acrylic Sealant CFS-S ACR.

The boards have to be positioned flush to the surface of the building element on each side of the wall.

Maximum distance for 1st service support: 250 mm.

Maximum seal size: 1200 x 1200 mm (width x height).

Minimum distances in mm metal pipe penetration seal:

$s_6, s_9 = 0$ (distance between pipes and lateral seal edge)

$s_7, s_{10} = 45$ (distance between pipes and upper seal edge)

$s_8, s_{11}, s_{12} = 30$ (distance between pipes)

Minimum distances in mm cable penetration seal:

$s_1 = 10$ (distance between cables/cable supports and seal edge)

$s_2 = 70$ (distance between cable supports)

$s_3 = 48$ (distance between cables and upper seal edge)

$s_4 = 0$ (distance between cable supports and bottom seal edge)

$s_5 = 80$ (distance between cables and cable support above)

For illustration of distances see Annex 2.2

Penetrating services (single or multiple):

In addition to the services referred to in Annex 2.2, Annex 2.3 and Annex 2.4 the following services with the classifications given below are covered:

2.5.1 Cables		
Construction details: see Annex 2.2.2		
	Classification	
Additional protection according to 1. 2:	AP ₃	AP ₄
All sheathed cable types currently and commonly used in building practice in Europe (e.g. power, control, signal, telecommunication, data, optical fibre cables, with or without cable supports, with a diameter of:		
Maximum Ø 21 mm	EI 120	EI 120
21 ≤ Ø ≤ 50 mm	EI 60	EI 90
50 ≤ Ø ≤ 80 mm	EI 60	EI 90
Non-sheathed cables (wires) currently and commonly used in building practice in Europe, with or without cable supports, with a diameter of:		
Maximum Ø 17 mm	EI 45	-
Maximum Ø 24 mm	EI 45	-
Tied cable bundle, maximum diameter of single cable 21 mm, with or without cable supports		
Maximum Ø 100 mm	EI 90	EI 120

2.5.2 Small conduits and tubes		
Construction details: see Annex 2.2.2		
	Classification	
Ø ≤ 16 mm, wall thickness ≥ 1 mm, arranged linear, with or without cables, with or without cable supports		
Additional protection according to 1.2:	AP ₃	AP ₄
Plastic conduits and tubes	EI 120-U/C	EI 120-U/C
Steel conduits and tubes	EI 120-C/U	EI 120-C/U

2.5.3 Metal pipes with foamed elastomeric insulation according Table 4 and Hilti Firestop Bandage CFS-B

Construction details (for symbols and abbreviations see Annex 4):

For specification of Armaflex AF see Table 4.

For specification of the foamed elastomeric insulation material to be used see Table 4.

Two layers of Firestop Bandage CFS-B (A_2) wrapped around the pipe insulation, on each side of the seal. The bandage is positioned with half of its width (62.5 mm) within the seal (central marking line at the surface of the seal) and outside the seal fixed with wire.

No additional protection.

Continued insulation, sustained (CS)

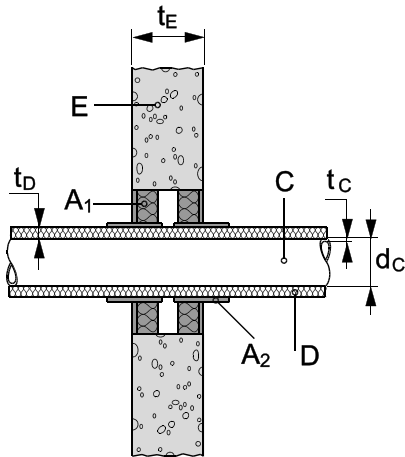

Local insulation, sustained (LS)

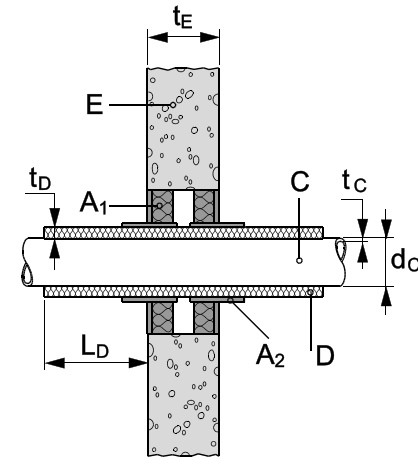

2.5.3.1 Steel pipes with foamed elastomeric insulation according Table 4 and Hilti Firestop Bandage CFS-B

Steel pipes (C) with continued insulation (D) – sustained – C/U

Pipe diameter (d_c) [mm]	Pipe wall thickness (t_c) [mm]	Insulation thickness (t_D) [mm]	Classification
60.3	3.6 - 14.2	21.5 - 39	EI 90-C/U
60.3 - 114.3	3.6 - 14.2	21.5 - 39	EI 60-C/U
60.3	3.6 - 14.2	39	EI 120-C/U
114.3	3.6 - 14.2	43	EI 90-C/U

Steel pipes (C) with local insulation (D) – sustained – C/U				
Pipe		Insulation		Classification
diameter (d _c) [mm]	wall thickness (t _c) [mm]	thickness (t _D) [mm]	length (L _D) [mm]	
60.3	3.6 - 14.2	21.5 - 39	≥ 500	EI 90-C/U
60.3 – 114.3	3.6 - 14.2	21.5 - 39	≥ 500	EI 60-C/U
60.3	3.6 - 14.2	39	≥ 500	EI 120-C/U
114.3	3.6 - 14.2	43	≥ 500	EI 90-C/U
The field of application given above for steel pipes is also valid for other metal pipes with lower heat conductivity than unalloyed steel and a melting point of minimum 1050°C, e.g. low alloyed steel, cast iron, stainless steels, Ni alloys (NiCu, NiCr and NiMo alloys)				
2.5.3.2 Stainless steel pipes with foamed elastomeric insulation according Table 4 and Hilti Firestop Bandage CFS-B				
Stainless steel pipes (C) with continued insulation (D) – sustained – C/U				
Pipe diameter (d _c) [mm]	Pipe wall thickness (t _c) [mm]	Insulation thickness (t _D) [mm]		Classification
60.3	2.0 - 14.2	21.5 - 39		EI 90-C/U
60.3	2.0 - 14.2	39		EI 120-C/U
Stainless steel pipes (C) with local insulation (D) – sustained – C/U				
Pipe		Insulation		Classification
diameter (d _c) [mm]	wall thickness (t _c) [mm]	thickness (t _D) [mm]	length (L _D) [mm]	
60.3	2.0 - 14.2	21.5 - 39	≥ 500	EI 90-C/U
60.3	2.0 - 14.2	39	≥ 500	EI 120-C/U

2.5.3.3 Copper pipes with foamed elastomeric insulation according Table 4 and Hilti Firestop Bandage CFS-B				
Copper pipes (C) with continued insulation (D) – sustained – C/U				
Pipe diameter (d _c) [mm]	Pipe wall thickness (t _c) [mm]	Insulation thickness (t _D) [mm]		Classification
28	1.0 - 14.2 ¹⁰	19 - 35		EI 60-C/U
28	1.0 - 14.2 ¹⁰	35		EI 120-C/U
Copper pipes (C) with local insulation (D) – sustained – C/U				
Insulation		Pipe		Classification
Pipe		Insulation		Classification
diameter (d _c) [mm]	wall thickness (t _c) [mm]	thickness (t _D) [mm]	length (L _D) [mm]	
28	1.0 - 14.2 ¹⁰	19 - 35	≥ 500	EI 60-C/U
28	1.0 - 14.2 ¹⁰	35	≥ 500	EI 120-C/U
The field of application given above for copper pipes is also valid for other metal pipes with lower heat conductivity than copper and a melting point of minimum 1100°C, e.g. unalloyed steel, low alloyed steel, cast iron, stainless steels, Ni alloys (NiCu, NiCr and NiMo alloys) and Ni.				

2.6 Rigid floors according to 1.2 e), minimum thickness 150 mm

Penetration seal:

Two 50 mm Hilti Firestop Boards CFS-CT B 1S⁸ (A₁) or mineral wool boards according to Table 1 coated with Hilti Firestop Coating CFS-CT (A₁), dry thickness of coating 0.7 mm on the outer side⁹, all cut edges of boards sealed with Hilti Firestop Acrylic Sealant CFS-S ACR, remaining gaps around cables / cable supports (trays, ladders etc.) and other services filled with Hilti Firestop Acrylic Sealant CFS-S ACR.

The boards have to be positioned flush to the surface of the building element on each side of the floor.

Maximum distance for 1st service support: 100 mm.

Maximum seal size: see Figure below.

Minimum distances in mm:

- S₁ = 0 (distance between cables/cable supports and seal edge)
- S₂ = 0 (distance between cable supports)
- S₃ = 0 (distance between cables and upper seal edge)
- S₄ = 0 (distance between cable supports and bottom seal edge)
- S₅ = 50 (distance between cables and cable support above)
- S₆ = 10 (distance between metal pipes and seal edge)
- S₈ = 20 (distance between metal pipes)
- S₉ = 0 (distance between plastic pipes/pipe closure devices and seal edge)
- S₁₁ = 0 (distance between plastic pipes/pipe closure devices)
- S₁₂ = 30 (distance between metal pipes and plastic pipes/pipe closure devices)
- S₁₃ = 30 (distance between cables/cable supports and metal pipes)
- S₁₄ = 32 (distance between cables/cable supports and plastic pipes / pipe closure devices)

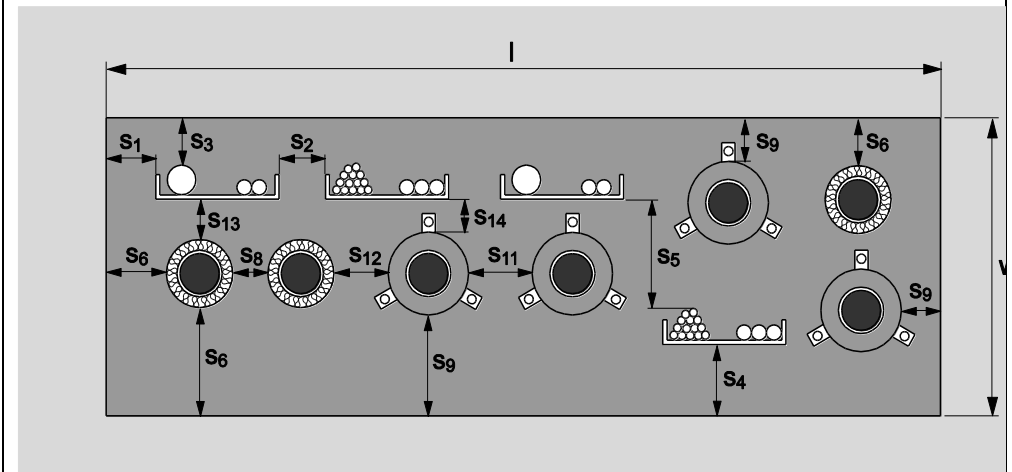

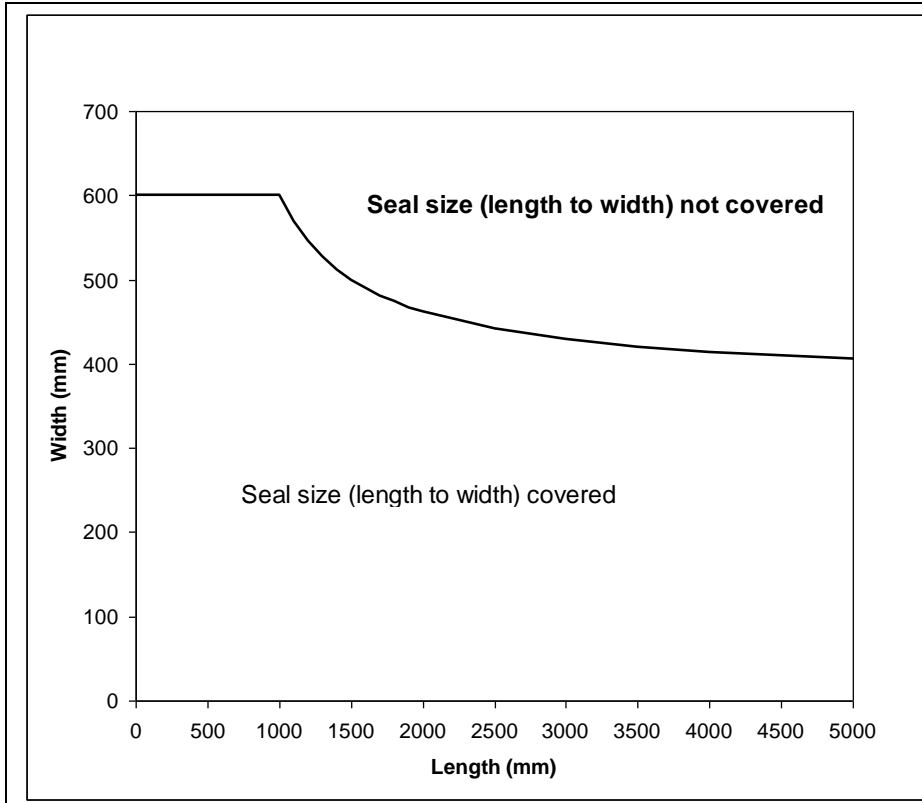

Seal sizes covered in all floor applications (length x width)

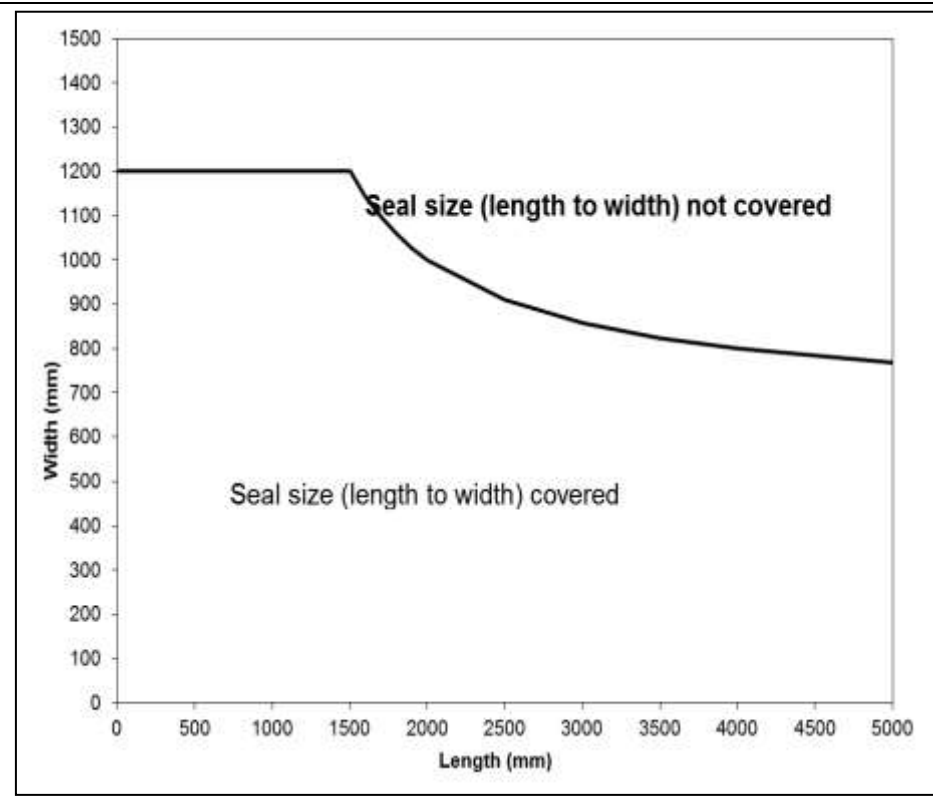

Seal sizes covered with additional supporting construction in all floor applications (length x width)

Penetrating services: (single, multiple or mixed)

2.6.1 Blank seal (no services) *

* If services are added later on in a blank seal only the services listed in the tables below may be added that fulfil the required classification

Construction details (for symbols and abbreviations see Annex 4):

Classification

Maximum size 600 x 1000 mm (width x length)

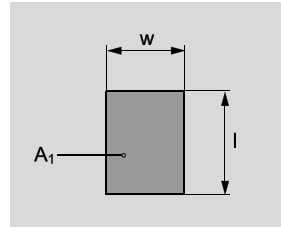
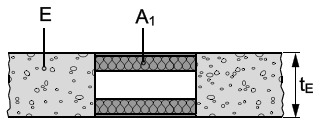

EI 180

Maximum size 1200 x 1500 mm (width x length)

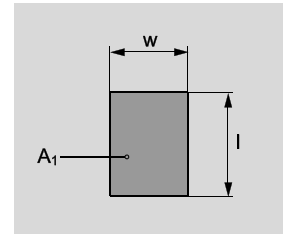
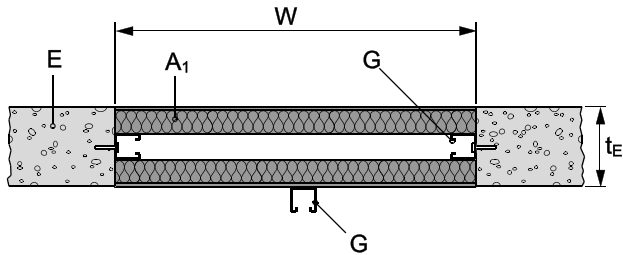

EI 90

With additional supporting construction: Two steel Hilti MQ-41/3 profiles between the two board layers, placed in longitudinal direction in the floor opening (fixed every 450mm with anchor bolts diameter 6mm, length 60mm) and a steel Hilti MQ-41/3 profile below the lower board layer placed in longitudinal direction of the seal (fixed on the floor at both ends with anchor bolts diameter 6mm, length 60mm).

2.6.2 Cables

(single, multiple or mixed)

Construction details (for symbols and abbreviations see Annex 4):

Additional protection AP₂ or AP₅ according to 1.2 may be used. AP₅ is illustrated below.

AP₂: cables/small conduits coated with Hilti Firestop Coating CFS-CT on both sides of seal over a length of the cables/small conduits of 200 mm from the surface of the seal, thickness 1 mm.

AP₅: Mineral wool mat according to Table 2, wrapped around cables /cable support (trays, ladders) on upper side of seal, Al-faced side outside, fixed with wire, width (length along the cables/small conduits) 200 mm, thickness 30 mm.

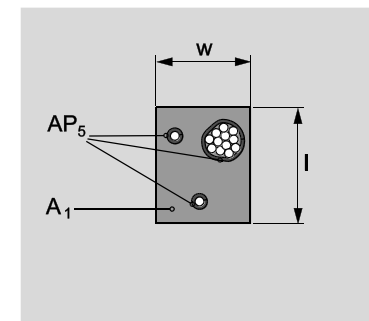
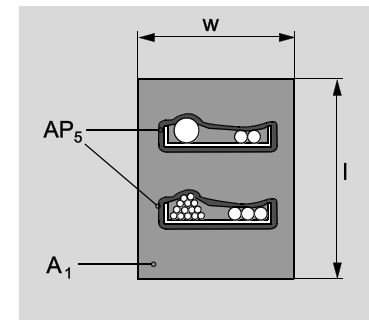
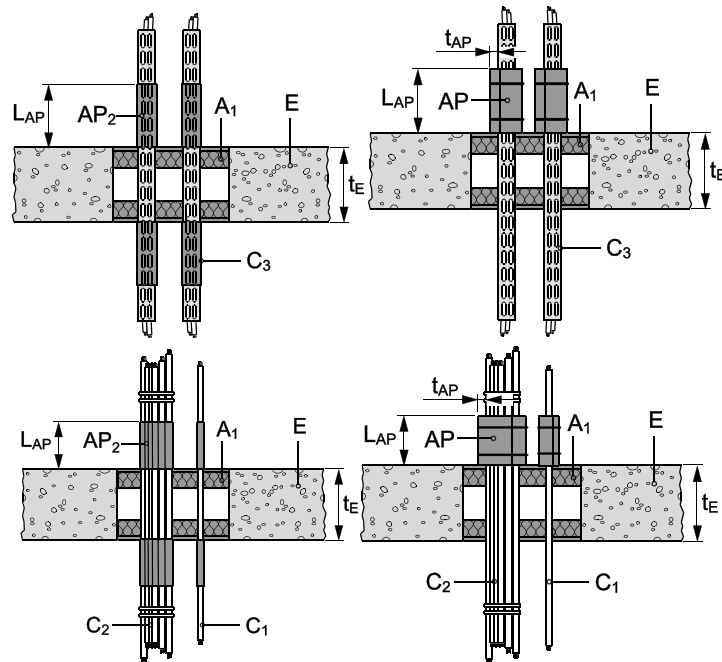

	Classification		
	with cable support (C ₃)	without cable support (C ₁ , C ₂)	with or without cable support
Additional protection:	AP ₂		AP ₅
All sheathed cable types currently and commonly used in building practice in Europe (e.g. power, control, signal, telecommunication, data, optical fibre cables, with a diameter of:			
Maximum Ø 21 mm	EI 90	EI 120	EI 120
21 ≤ Ø ≤ 50 mm	EI 60	EI 60	EI 120
50 ≤ Ø ≤ 80 mm	EI 60	EI 60	EI 120
Non-sheathed cables (wires) currently and commonly used in building practice in Europe, with a diameter of:			
Maximum Ø 24 mm	EI 60	EI 60	-
Tied cable bundle, maximum diameter of single cable 21 mm			
Maximum Ø 100 mm	EI 90	EI 120	EI 120

2.6.3 Small conduits and tubes

(single, multiple or mixed)

Construction details: see Annex 2.6.2

	Classification		
	with cable support (C ₃)	without cable support (C ₁ , C ₂)	with or without cable support
Additional protection:	AP ₂		AP ₅
Ø ≤ 16 mm, wall thickness ≥ 1 mm, arranged linear, with or without cables			
Plastic conduits and tubes	EI 90-U/C	EI 120-U/C	EI 90-U/C
Steel conduits and tubes	EI 90-C/U	EI 120-C/U	EI 90-C/U

2.6.3.1 3 plastic conduits in 1 Hilti Firestop Collar CFS-C P – U/C

With and without cables

Construction details (for symbols and abbreviations see Annex 4):

Hilti Firestop Collar CFS-C P (A_3) is installed on the bottom side of the seal, fixed by threaded rods, washers and nuts as specified in Annex 1.2.

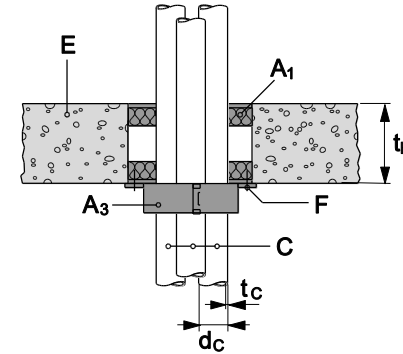

Pipe diameter (d_c) [mm]	Pipe wall thickness t_c [mm]	Pipe material / standard	Collar size (A_3)	No. of hooks	Classification
16	1.0	PVC,	CFS-C P 63/2"	3	EI 90-U/C
25	1.5	PVC			
35	2	Polyolefin			

2.6.4 Metal pipes

2.6.4.1 Metal pipes with mineral wool insulation according to Table 3

Construction details (for symbols and abbreviations see Annex 4):

Additional protection AP₈ according to 1.2 may be used.

AP₈: Mineral wool mat according to Table 2, wrapped on both sides of the seal around the pipe insulation, fixed with wire, length along the pipe 250 mm, thickness 40 mm.

Continued insulation, interrupted (CI)

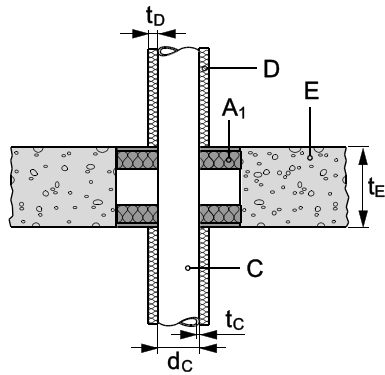

Local insulation, interrupted (LI)

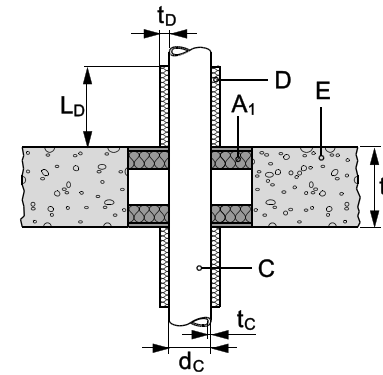

Continued insulation, sustained (CS)

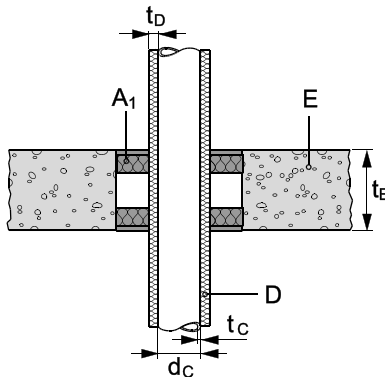

Local insulation, sustained (LS)

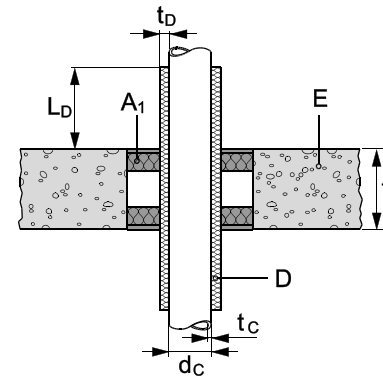

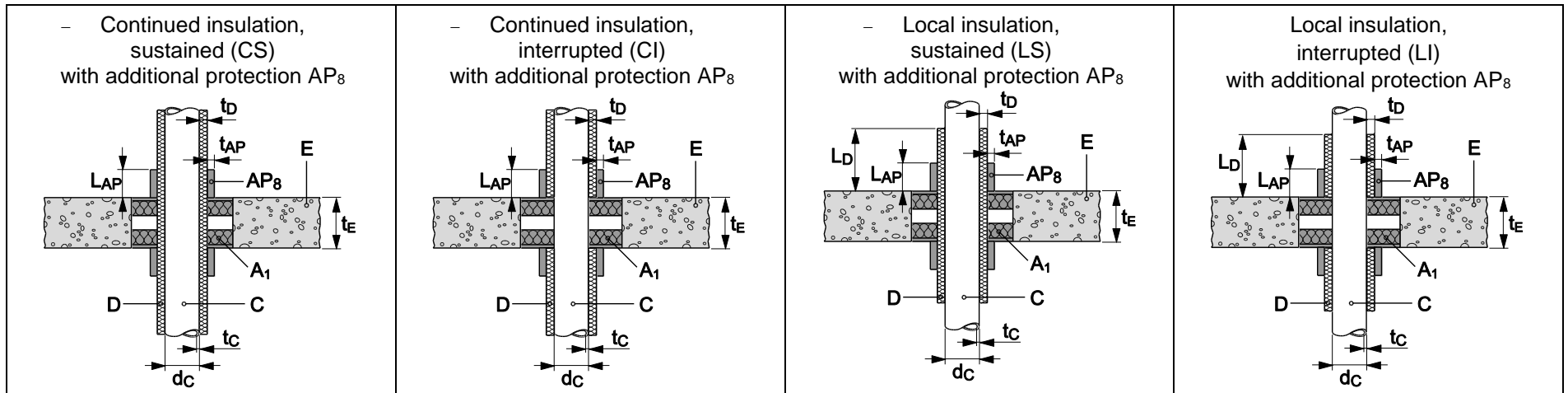

2.6.4.1.1 Steel pipes with mineral wool insulation according to Table 3

Steel pipes (C) with continued insulation (D) – sustained – C/U

Pipe diameter (d_c) [mm]	Pipe wall thickness (t_c) [mm]	Insulation thickness (t_D) [mm]	Classification
48.3	1.6 - 14.2 ¹⁰	≥ 20	EI 180-C/U
114.3	3.6	≥ 40	EI 120-C/U

Steel pipes (C) with continued insulation (D) – sustained – U/C

Pipe diameter (d_c) [mm]	Pipe wall thickness (t_c) [mm]	Insulation thickness (t_D) [mm]	Classification	
Additional protection according 1.2			-	AP ₈
114.3	2.0 – 14.2	≥ 30	EI 120-U/C	-
114.3 – 159	2.0/2.6 - 14.2 ¹¹	≥ 40	EI 120-U/C	-
159 – 323.9	2.6/4.0 - 14.2 ¹²	≥ 40	EI 90-U/C	EI 120-U/C

Steel pipes (C) with continued insulation (D) – interrupted – C/U				
Pipe diameter (d _c) [mm]	Pipe wall thickness (t _c) [mm]	Insulation thickness (t _D) [mm]		Classification
26.9	1.4 – 14.2 ¹⁰	≥ 40		EI 180-C/U
32	4.0 - 14.2 ¹⁰	≥ 20		EI 120-C/U
48.3	1.6 – 14.2 ¹⁰	≥ 20		EI 180-C/U
34 - 168.3	2.6 - 14.2 ¹⁰	≥ 30		EI 120-C/U
Steel pipes (C) with continued insulation (D) – interrupted – U/C				
Pipe diameter (d _c) [mm]	Pipe wall thickness (t _c) [mm]	Insulation thickness (t _D) [mm]		Classification
Additional protection according 1.2			-	AP ₈
114.3	2.0 – 14.2	≥ 30		EI 120-U/C
114.3 – 159	2.0/2.6 - 14.2 ¹¹	≥ 40		EI 120-U/C
159 – 323.9	2.6/4.0 - 14.2 ¹²	≥ 40		EI 90-U/C
EI 120-U/C				
Steel pipes (C) with local insulation (D) – sustained – C/U				
Pipe		Insulation		Classification
diameter (d _c) [mm]	wall thickness (t _c) [mm]	thickness (t _D) [mm]	length (L _D) [mm]	
48.3	1.6 - 14.2 ¹⁰	20	≥ 450	EI 180-C/U
114.3	3.6	40	≥ 500	EI 120-C/U
Steel pipes (C) with local insulation (D) – sustained – U/C				
Pipe		Insulation		Classification
diameter (d _c) [mm]	wall thickness (t _c) [mm]	thickness (t _D) [mm]	length (L _D) [mm]	
Additional protection according 1.2			-	AP ₈
114.3	2.0 – 14.2	30 – 40	≥ 500	EI 120-U/C
114.3 – 159	2.0/2.6 - 14.2 ¹¹	40	≥ 500	EI 90-U/C
114.3 – 159	2.0/2.6 - 14.2 ¹¹	40	≥ 1000	EI 120-U/C
159 – 323.9	2.6/4.0 - 14.2 ¹²	40	≥ 1000	EI 60-U/C
EI 90-U/C				

Steel pipes (C) with local insulation (D) – interrupted – C/U					
Pipe		Insulation		Classification	
diameter (d _c) [mm]	wall thickness (t _c) [mm]	thickness (t _D) [mm]	length (L _D) [mm]		
26.9	1.4 – 14.2 ¹⁰	40	≥ 500	EI 180-C/U	
32	4.0 - 14.2 ¹⁰	20	≥ 500	EI 120-C/U	
48.3	1.6 – 14.2 ¹⁰	20	≥ 500	EI 180-C/U	
32 - 114.3	2.6 - 14.2 ¹⁰	30	≥ 500	EI 120-C/U	
32 - 168.3	2.6 - 14.2 ¹⁰	30	≥ 800	EI 120-C/U	
168.3	4.0 - 14.2	30 - 40	≥ 1000	EI 120-C/U	
Steel pipes (C) with local insulation (D) – interrupted – U/C					
Pipe		Insulation		Classification	
diameter (d _c) [mm]	wall thickness (t _c) [mm]	thickness (t _D) [mm]	length (L _D) [mm]		
Additional protection according 1.2				-	AP ₈
114.3	2.0 – 14.2	30 – 40	≥ 500	EI 120-U/C	-
114.3 – 159	2.0/2.6 - 14.2 ¹¹	40	≥ 500	EI 90-U/C	-
114.3 – 159	2.0/2.6 - 14.2 ¹¹	40	≥ 1000	EI 120-U/C	-
159 – 323.9	2.6/4.0 - 14.2 ¹²	40	≥ 1000	EI 60-U/C	EI 90-U/C
The field of application given above for steel pipes is also valid for other metal pipes with lower heat conductivity than unalloyed steel and a melting point of minimum 1050°C, e.g. low alloyed steel, cast iron, stainless steels, Ni alloys (NiCu, NiCr and NiMo alloys)					

2.6.4.1.2 Metal pipes with mineral wool insulation according to Table 3

Copper pipes (C) with continued insulation (D) – sustained – C/U

Pipe diameter (d _c) [mm]	Pipe wall thickness (t _c) [mm]	Insulation thickness (t _D) [mm]	Classification
28 – 42	1.0/1.5 - 14.2 ^{10,13}	≥ 20	EI 120-C/U
88.9	1.8 - 14.2	≥ 40	EI 120-C/U

Copper pipes (C) with continued insulation (D) – sustained – U/C

Pipe		Insulation	Classification
diameter (d _c) [mm]	wall thickness (t _c) [mm]	thickness (t _D) [mm]	
10 - 40	1.0/1.5 - 14.2 ^{10,14}	≥ 20	EI 120-U/C
40	1.5 – 14.2 ¹⁰	≥ 40	EI 120-U/C
40 – 88.9	1.5/2.0 – 14.2 ^{10,15}	≥ 40	EI 90-U/C

Copper pipes (C) with continued insulation (D) – interrupted – C/U

Pipe diameter (d _c) [mm]	Pipe wall thickness (t _c) [mm]	Insulation thickness (t _D) [mm]	Classification
28	1.0 – 14.2 ¹⁰	≥ 20	EI 120-C/U
28 – 42	1.0/1.5 - 14.2 ^{10,13}	≥ 40	EI 120-C/U
42	1.5 - 14.2 ¹⁰	≥ 20	EI 120-C/U

Copper pipes (C) with continued insulation (D) – interrupted – U/C

Pipe		Insulation	Classification
diameter (d _c) [mm]	wall thickness (t _c) [mm]	thickness (t _D) [mm]	
10 - 40	1.0/1.5 - 14.2 ^{10,14}	≥ 20	EI 120-U/C
40 – 88.9	1.5/2.0 – 14.2 ^{10,15}	≥ 40	EI 120-U/C

Copper pipes (C) with local insulation (D) – sustained – C/U					
Pipe		Insulation		Classification	
diameter (d _c) [mm]	wall thickness (t _c) [mm]	thickness (t _D) [mm]	length (L _D) [mm]		
28 – 42	1.0/1.5 - 14.2 ^{10,13}	20	≥ 450	EI 120-C/U	
42	1.5 - 14.2 ¹⁰	20 – 40	≥ 800	EI 120-C/U	
88.9	1.8 - 14.2	40	≥ 800	EI 120-C/U	
Copper pipes (C) with local insulation (D) – sustained – U/C					
Pipe		Insulation		Classification	
diameter (d _c) [mm]	wall thickness (t _c) [mm]	thickness (t _D) [mm]	length (L _D) [mm]		
Additional protection according 1.2				-	AP ₈
10 - 40	1.0/1.5 - 14.2 ^{10,14}	20	≥ 500	EI 120-U/C	-
40	1.5 - 14.2 ¹⁰	40	≥ 1000	EI 120-U/C	-
40 – 88.9	1.5/2.0 – 14.2 ^{10,15}	40	≥ 1000	EI 60-U/C	EI 90-U/C
Copper pipes (C) with local insulation (D) – interrupted – C/U					
Pipe		Insulation		Classification	
diameter (d _c) [mm]	wall thickness (t _c) [mm]	thickness (t _D) [mm]	length (L _D) [mm]		
28	1.0 – 14.2 ¹⁰	20	≥ 500	EI 120-C/U	
42	1.5 - 14.2 ¹⁰	20	≥ 500	EI 120-C/U	
42	1.5 - 14.2 ¹⁰	40	≥ 800	EI 120-C/U	
Copper pipes (C) with local insulation (D) – interrupted – U/C					
Pipe		Insulation		Classification	
diameter (d _c) [mm]	wall thickness (t _c) [mm]	thickness (t _D) [mm]	length (L _D) [mm]		
10 - 40	1.0/1.5 - 14.2 ^{10,14}	20	≥ 500	EI 120-U/C	
40	1.5 - 14.2 ¹⁰	40	≥ 1000	EI 120-U/C	
40 – 88.9	1.5/2.0 – 14.2 ^{10,15}	40	≥ 1000	EI 90-U/C	
The field of application given above for copper pipes is also valid for other metal pipes with lower heat conductivity than copper and a melting point of minimum 1100°C, e.g. unalloyed steel, low alloyed steel, cast iron, stainless steels, Ni alloys (NiCu, NiCr and NiMo alloys) and Ni.					

2.6.4.2 Metal pipes with foamed elastomeric insulation according Table 4 and Hilti Firestop Bandage CFS-B,

Construction details (for symbols and abbreviations see Annex 4):

For specification of the foamed elastomeric insulation material to be used, see Table 4.

Two layers of Firestop Bandage CFS-B (A_2) wrapped around the pipe insulation, on each side of the seal. The bandage is positioned with half of its width (62.5 mm) within the seal (central marking line at the surface of the seal) and outside the seal fixed with wire.

No additional protection.

Continued insulation, sustained (CS)

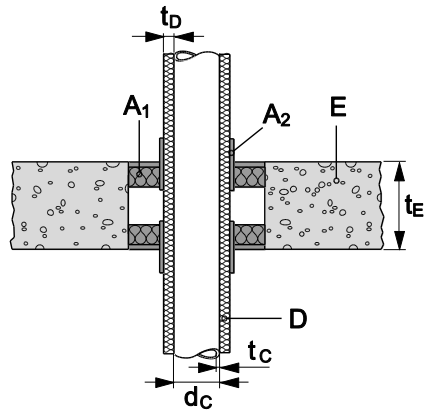

Local insulation, sustained (LS)

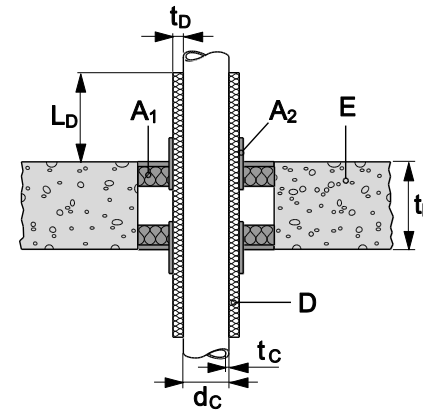

2.6.4.2.1 Steel pipes with foamed elastomeric insulation according Table 4 and Hilti Firestop Bandage CFS-B

Steel pipes (C) with continued insulation (D) – sustained – C/U

Pipe diameter (d_c) [mm]	Pipe wall thickness (t_c) [mm]	Insulation thickness (t_D) [mm]	Classification
60.3	3.6 - 14.2 ¹⁰	21.5 - 39	EI 90-C/U
60.3 - 114.3	3.6 - 14.2 ¹⁰	21.5 - 39	EI 90-C/U

Steel pipes (C) with local insulation (D) – sustained – C/U				
Pipe		Insulation		Classification
diameter (d _c) [mm]	wall thickness (t _c) [mm]	thickness (t _D) [mm]	length (L _D) [mm]	
60.3	3.6 - 14.2 ¹⁰	21.5 - 39	≥ 500	EI 90-C/U
60.3 - 114.3	3.6 - 14.2 ¹⁰	21.5 - 39	≥ 500	EI 90-C/U
The field of application given above for steel pipes is also valid for other metal pipes with lower heat conductivity than unalloyed steel and a melting point of minimum 1050°C, e.g. low alloyed steel, cast iron, stainless steels, Ni alloys (NiCu, NiCr and NiMo alloys)				
2.6.4.2.2 Stainless steel pipes with foamed elastomeric insulation according Table 4 and Hilti Firestop Bandage CFS-B				
Stainless steel pipes (C) with continued insulation (D) – sustained – C/U				
Pipe diameter (d _c) [mm]	Pipe wall thickness (t _c) [mm]	Insulation thickness (t _D) [mm]		Classification
60.3	2.0 - 14.2 ¹⁰	21.5 - 39		EI 90-C/U
60.3	2.0 - 14.2 ¹⁰	39		EI 120-C/U
Stainless steel pipes (C) with local insulation (D) – sustained – C/U				
Pipe		Insulation		Classification
diameter (d _c) [mm]	wall thickness (t _c) [mm]	thickness (t _D) [mm]	length (L _D) [mm]	
60.3	2.0 - 14.2 ¹⁰	21.5 - 39	≥ 500	EI 90-C/U
60.3	2.0 - 14.2 ¹⁰	39	≥ 500	EI 120-C/U
2.6.4.2.3 Copper pipes with foamed elastomeric insulation according Table 4 and Hilti Firestop Bandage CFS-B				
Copper pipes (C) with continued insulation (D) – sustained – C/U				
Pipe diameter (d _c) [mm]	Pipe wall thickness (t _c) [mm]	Insulation thickness (t _D) [mm]		Classification
28	1.0 - 14.2 ¹⁰	19 - 35		EI 60-C/U
28	1.0 - 14.2 ¹⁰	35		EI 90-C/U

Copper pipes (C) with local insulation (D) – sustained – C/U				
Pipe		Insulation		Classification
diameter (d_c) [mm]	wall thickness (t_c) [mm]	thickness (t_D) [mm]	length (L_D) [mm]	
28	1.0 - 14.2 ¹⁰	19 - 35	≥ 500	EI 60-C/U
28	1.0 - 14.2 ¹⁰	35	≥ 500	EI 90-C/U

The field of application given above for copper pipes is also valid for other metal pipes with lower heat conductivity than copper and a melting point of minimum 1100°C, e.g. unalloyed steel, low alloyed steel, cast iron, stainless steels, Ni alloys (NiCu, NiCr and NiMo alloys) and Ni.

2.6.4.3 Metal pipes with foamed elastomeric insulation according Table 4 and Hilti Firestop Bandage CFS-B and additional protection	
<p>Construction details (for symbols and abbreviations see Annex 4):</p> <p>For specification of the foamed elastomeric insulation material to be used see Table 4.</p> <p>Two layers of Firestop Bandage CFS-B (A_2) wrapped around the pipe insulation on the bottom side of the seal. The bandage is positioned with half of its width (62.5 mm) within the seal (central marking line at the surface of the seal) and outside the seal fixed with wire.</p> <p>Additional protection: Over the bandage/pipe insulation an additional protection AP_6 according to 1.2 is installed:</p> <p>AP_6: AF/Armaflex pipe insulation wrapped around the bandage/pipe insulation on each side of the seal, fixed with wire, length (L_{AP}) = 250 mm on each side, thickness (t_{AP}) = 32 mm.</p>	<p>Continued insulation, sustained (CS)</p>

Steel pipes (C) with continued insulation (D) – sustained – U/C			
Pipe diameter (d_c) [mm]	Pipe wall thickness (t_c) [mm]	Insulation thickness (t_D) [mm]	Classification
114.3	2.0 – 14.2	9 - 42	EI 90-U/C
159	2.6 – 14.2	10	EI 90-U/C
Copper pipes (C) with continued insulation (D) – sustained – U/C			
Pipe diameter (d_c) [mm]	Pipe wall thickness (t_c) [mm]	Insulation thickness (t_D) [mm]	Classification
10	1.0 – 14.2 ¹⁰	7.5 – 40.5	EI 120-U/C
10 – 40	1.0/1.5 - 14.2 ^{10,14}	45.5 – 47.5	EI 90-U/C
40 – 88.9	1.5/2.0 - 14.2 ^{10,15}	7.5 – 9.0	EI 120-U/C

2.6.5 Plastic pipes with Hilti Firestop Collar CFS-C P

Construction details

(for symbols and abbreviations see Annex 4):

Hilti Firestop Collar CFS-C P (A_3) is installed on the bottom side of the seal, fixed by threaded rods, washers and nuts as specified in Annex 1.2.

In some cases an additional protection is required:

AP_9 : Mineral wool board according to table 1 installed around the pipe in the air gap between the two layers of the Hilti Firestop Double Board Seal. Distance on all sides of the pipe 100 mm, depth 50 mm (height of the air gap).

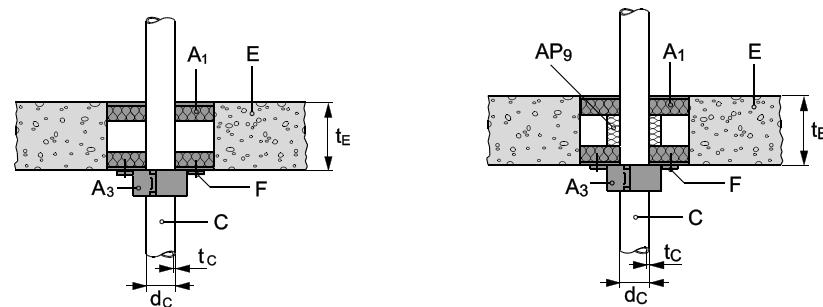

2.6.5.1 PVC-U pipes (C) according to EN ISO 1452-2, EN ISO 15493, DIN 8061/8062 with Hilti Firestop Collar CFS-C P

PVC-U pipes (C) according to EN ISO 1452-2, EN ISO 15493, DIN 8061/8062 – U/U,

Pipe diameter (d _c) [mm]	Pipe wall thickness t _c [mm]	Collar size (A ₃)	No. of hooks	Classification
Additional protection				AP ₉
20	1.5 – 2.2	CFS-C P 50/1.5"	2	EI 120-U/U
50	2.4 – 5.6	CFS-C P 50/1.5"	2	EI 120-U/U
63	3.0 – 4.7	CFS-C P 63/2"	3	EI 120-U/U
75	2.2 – 3.6	CFS-C P 75/2.5"	3	EI 120-U/U
90	2.7 – 4.3	CFS-C P 90/3"	4	EI 120-U/U
110	1.8 – 8.1	CFS-C P 110/4"	4	EI 120-U/U

The results are also valid for PVC-U pipes according EN 1329-1¹⁶ and EN 1453-1¹⁷ and PVC-C pipes according EN 1566-1.

PVC-U pipes (C) according to EN ISO 1452-2, EN ISO 15493, DIN 8061/8062 – U/C,

Pipe diameter (d _c) [mm]	Pipe wall thickness t _c [mm]	Collar size (A ₃)	No. of hooks	Classification
Additional protection				-
50	1.8	CFS-C P 50/1.5"	2	EI 120-U/C
160	1.8 – 11.9	CFS-C P 160/6"	6	EI 120-U/C

The results are also valid for PVC-U pipes according EN 1329-1¹⁶ and EN 1453-1¹⁷ and PVC-C pipes according EN 1566-1.

PVC-U pipes (C) according to EN ISO 1452-2, EN ISO 15493, DIN 8061/8062 – C/U

Pipe diameter (d _c) [mm]	Pipe wall thickness t _c [mm]	Collar size (A ₃)	No. of hooks	Classification
Additional protection				-
125	3.7 – 6.0	CFS-C P 125/5"	4	EI 120-C/U
125	3.7	CFS-C P 125/5"	4	EI 180-C/U
160	2.5 – 11.8	CFS-C P 160/6"	6	EI 120-C/U

2.6.5.2 PE pipes (C) according to EN ISO 15494, DIN 8074/8075 with Hilti Firestop Collar CFS-C P

PE pipes (C) according to EN ISO 15494, DIN 8074/8075 – U/U

Pipe diameter (d _c) [mm]	Pipe wall thickness t _c [mm]	Collar size (A ₃)	No. of hooks	Classification
Additional protection				AP ₉
50	2.9 – 4.6	CFS-C P 50/1.5"	2	EI 120-U/U
63	1.8 – 5.8	CFS-C P 63/2"	3	EI 120-U/U
75	1.9 – 6.8	CFS-C P 75/2.5"	3	EI 120-U/U
90	2.2 – 8.2	CFS-C P 90/3"	4	EI 120-U/U
110	2.7 – 10.0	CFS-C P 110/4"	4	EI 120-U/U

PE pipes (C) according to EN ISO 15494, DIN 8074/8075 – U/C

Pipe diameter (d _c) [mm]	Pipe wall thickness t _c [mm]	Collar size (A ₃)	No. of hooks	Classification
Additional protection				-
160	14.6	CFS-C P 160/6"	6	EI 120-U/C

PE pipes (C) according to EN ISO 15494, DIN 8074/8075 – C/U

Pipe diameter (d _c) [mm]	Pipe wall thickness t _c [mm]	Collar size (A ₃)	No. of hooks	Classification
Additional protection				AP ₉
125	3.1 – 7.1	CFS-C P 125/5"	4	EI 180-C/U
160	14.6	CFS-C P 160/6"	6	EI 180-C/U

2.6.5.3 PE pipes (C) according to EN 1519¹⁸ with Hilti Firestop Collar CFS-C P

PE pipes (C) according to EN 1519¹⁸– U/U

Pipe diameter (d _c) [mm]	Pipe wall thickness t _c [mm]	Collar size (A ₃)	No. of hooks	Classification
Additional protection				AP ₉
50	3.0	CFS-C P 50/1.5"	2	EI 120-U/U
63	3.0	CFS-C P 63/2"	3	EI 120-U/U
75	3.0	CFS-C P 75/2.5"	3	EI 120-U/U
90	3.5	CFS-C P 90/3"	4	EI 120-U/U
110	4.2	CFS-C P 110/4"	4	EI 120-U/U

PE pipes (C) according to EN 1519¹⁸ – C/U

Pipe diameter (d _c) [mm]	Pipe wall thickness t _c [mm]	Collar size (A ₃)	No. of hooks	Classification
Additional protection				AP ₉
125	4.8	CFS-C P 125/5"	4	EI 180-C/U
160	6.2	CFS-C P 160/6"	6	EI 180-C/U

2.6.5.4 PE-S2 pipes “Geberit Silent-db20” with Hilti Firestop Collar CFS-C P				
Manufacturer: Geberit Int.				
PE-S2 pipes “Geberit Silent-db20”– U/U				
Pipe diameter (d _c) [mm]	Pipe wall thickness t _c [mm]	Collar size (A ₃)	No. of hooks	Classification
			Additional protection	AP ₉
75	3.6	CFS-C P 75/2.5”	3	EI 120-U/U
90	5.5	CFS-C P 90/3”	4	EI 120-U/U
PE-S2 pipes “Geberit Silent-db20”– C/U				
Pipe diameter (d _c) [mm]	Pipe wall thickness t _c [mm]	Collar size (A ₃)	No. of hooks	Classification
			Additional protection	AP ₉
110	6.0	CFS-C P 110/4”	4	EI 120-C/U
135	6.0	CFS-C P 160/6”	6	EI 180-C/U
160	7.0	CFS-C P 160/6”	6	EI 180-C/U

2.6.5.5 PE-HD 100 RC pipes “Wavin TS”– U/C with Hilti Firestop Collar CFS-C P

Manufacturer: Wavin Ireland Ltd.

Pipe diameter (d _c) [mm]	Pipe wall thickness t _c [mm]	Collar size (A ₃)	No. of hooks	Classification
Additional protection				AP ₉
50	4.6	CFS-C P 50/1.5”	2	EI 90-U/C
63	5.8	CFS-C P 63/2”	2	EI 120-U/C
75	6.8	CFS-C P 75/2.5”	3	EI 120-U/C
90	8.2	CFS-C P 90/3”	3	EI 120-U/C
110	10	CFS-C P 110/4”	4	EI 120-U/C

2.6.5.6 Non-regulated PP pipes with Hilti Firestop Collar CFS-C P**2.6.5.6.1 PP pipes , non regulated**

For pipe type and manufacturer refer to 2.1.6.

Pipe diameter (d _c) [mm]	Pipe wall thickness t _c [mm]	Collar size (A ₃)	No. of hooks	Classification
Additional protection				AP ₉
50	1.8 -2.0	CFS-C P 50/1.5”	2	EI 90-U/U
58	4.0	CFS-C P 63/2”	2	EI 90-U/U
70	4.5	CFS-C P 75/2.5”	3	EI 90-U/U
75	1.9 – 3.8	CFS-C P 75/2.5”	3	EI 90-U/U
78	4.5	CFS-C P 75/2.5”	3	EI 90-U/U
90	2.8 - 4.5	CFS-C P 90/3”	3	EI 90-U/U
110	2.7 – 5.3	CFS-C P 110/4”	4	EI 90-U/U

2.6.5.6.2 PP pipes “Raupiano Plus”– U/U

Manufacturer: Rehau AG,

Pipe diameter (d _c) [mm]	Pipe wall thickness t _c [mm]	Collar size (A ₃)	No. of hooks	Classification
Additional protection				AP ₉
50	1.8	CFS-C P 50/1.5”	2	EI 120-U/U
75	1.9	CFS-C P 75/2.5”	3	EI 120-U/U
110	2.7	CFS-C P 110/4”	4	EI 120-U/U

2.6.5.6.3 PP pipes „Skolan-dB”– U/U

Manufacturer: Magnaplast GmbH,

Pipe diameter (d _c) [mm]	Pipe wall thickness t _c [mm]	Collar size (A ₃)	No. of hooks	Classification
Additional protection				AP ₉
58	4.0	CFS-C P 63/2”	2	EI 120-U/U
78	4.5	CFS-C P 75/2.5”	3	EI 120-U/U
90	4.5	CFS-C P 90/3”	3	EI 120-U/U
110	5.3	CFS-C P 110/4”	4	EI 120-U/U

2.6.5.6.4 PP pipes “Wavin AS” or “Phonex AS”– U/U

Manufacturer: Wavin Ireland Ltd or KeKelit

Pipe diameter (d _c) [mm]	Pipe wall thickness t _c [mm]	Collar size (A ₃)	No. of hooks	Classification
Additional protection				AP ₉
70	4.5	CFS-C P 75/2.5”	3	EI 120-U/U
90	4.5	CFS-C P 90/3”	3	EI 120-U/U

2.6.5.6.5 PP pipes “Wavin SiTech”– U/U

Manufacturer: Wavin Ireland Ltd.

Pipe diameter (d _c) [mm]	Pipe wall thickness t _c [mm]	Collar size (A ₃)	No. of hooks	Classification
Additional protection				AP ₉

75	2.3	CFS-C P 75/2.5"	3	EI 120-U/U
90	2.8	CFS-C P 90/3"	3	EI 120-U/U
2.6.5.6.6 Non-regulated PP pipes – C/U				
For pipe type and manufacturer refer to 2.1.6.				
Pipe diameter (d _c) [mm]	Pipe wall thickness t _c [mm]	Collar size (A ₃)	No. of hooks	Classification
Additional protection			AP ₉	
110	5.3	CFS-C P 110/4"	4	EI 120-C/U
125	3.1 – 5.3	CFS-C P 125/5"	4	EI 180-C/U
135	5.3 – 5.8	CFS-C P 160/6"	6	EI 180-C/U
160	3.9 – 7.5	CFS-C P 160/6"	6	EI 180-C/U

2.6.5.7 PP pipes according to EN ISO 15874 and/or DIN 8077/8078 with Hilti Firestop Collar CFS-C P				
2.6.5.7.1 PP-H pipes "PROGEF standard pipe" according DIN 8077/8078 – U/U				
Manufacturer: Georg Fischer				
Pipe diameter (d _c) [mm]	Pipe wall thickness t _c [mm]	Collar size (A ₃)	No. of hooks	Classification
			Additional protection	AP ₉
20	1.9	CFS-C P 50/1.5"	2	EI 120-U/U
50	2.9	CFS-C P 50/1.5"	2	EI 120-U/U
63	5.8	CFS-C P 63/2"	3	EI 120-U/U
75	6.8	CFS-C P 75/2.5"	3	EI 120-U/U
90	8.2	CFS-C P 90/3"	3	EI 120-U/U
2.6.5.7.2 PP-H 100 pipes "Dekaprop Industry pipes" according DIN 8077/8078 – U/U				
Manufacturer: Georg Fischer				
Pipe diameter (d _c) [mm]	Pipe wall thickness t _c [mm]	Collar size (A ₃)	No. of hooks	Classification
			Additional protection	AP ₉
50	1.8	CFS-C P 50/1.5"	2	EI 120-U/U
63	1.8	CFS-C P 63/2"	3	EI 120-U/U
75	1.9	CFS-C P 75/2.5"	3	EI 120-U/U
90	2.2	CFS-C P 90/3"	3	EI 120-U/U
110	2.7	CFS-C P 110/4"	4	EI 120-U/U
2.6.5.7.3 PP-R pipes "Fusiotherm" according EN ISO 15874 – U/U				
Manufacturer: Aquatherm				
Pipe diameter (d _c) [mm]	Pipe wall thickness t _c [mm]	Collar size (A ₃)	No. of hooks	Classification
			Additional protection	AP ₉
20	3.4	CFS-C P 50/1.5"	2	EI 120-U/U

2.6.5.8 PP pipes according to EN ISO 15874 and/or DIN 8077/8078 with Hilti Firestop Collar CFS-C P				
2.6.5.8.1 PP-H pipes “PROGEF standard pipe” according DIN 8077/8078 – U/C				
Manufacturer: Georg Fischer				
Pipe diameter (d _c) [mm]	Pipe wall thickness t _c [mm]	Collar size (A ₃)	No. of hooks	Classification
Additional protection			AP ₉	
50	4.6	CFS-C P 50/1.5”	2	EI 120-U/C
63	5.8	CFS-C P 63/2”	3	EI 120-U/C
75	6.8	CFS-C P 75/2.5”	3	EI 120-U/C
90	8.2	CFS-C P 90/3”	3	EI 120-U/C
2.6.5.8.2 PP-R pipes “Fusiotherm” according EN ISO 15874 – U/C				
Manufacturer: Aquatherm				
Pipe diameter (d _c) [mm]	Pipe wall thickness t _c [mm]	Collar size (A ₃)	No. of hooks	Classification
Additional protection			AP ₉	
40	3.7 – 5.5	CFS-C P 50/1.5”	2	EI 120-U/C
50	4.6 – 6.9	CFS-C P 50/1.5”	2	EI 120-U/C
63	10.5	CFS-C P 63/2”	3	EI 120-U/C
75	6.8 – 12.5	CFS-C P 75/2.5”	3	EI 120-U/C
90	15.0	CFS-C P 90/3”	3	EI 120-U/C
110	10.0 – 15.1	CFS-C P 110/4”	4	EI 120-U/C
2.6.5.8.3 PP-R FS pipes “Firestop” according EN ISO 15874 and DIN 8077/8078– U/C				
Manufacturer: Aquatherm				
Pipe diameter (d _c) [mm]	Pipe wall thickness t _c [mm]	Collar size (A ₃)	No. of hooks	Classification
Additional protection			AP ₉	
90	12.3	CFS-C P 90/3”	3	EI 120-U/C
2.6.5.9 ABS/PUR/PE-HD pipes “Coolfit”– U/C with Hilti Firestop Collar CFS-C P				
Manufacturer: +GF+ Georg Fischer Piping Systems.				

Pipe/hose for wood pellet transport with Hilti Firestop Collar CFS-C P – U/C

Construction details
(for symbols and abbreviations see Annex 4):

Hilti Firestop Collar CFS-C P (A_3) is installed on the bottom side of the seal, fixed by threaded rods, washers and nuts as specified in Annex 1.2.

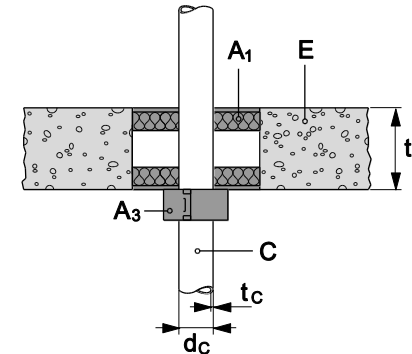

Pipe diameter (d_c) [mm]	Pipe wall thickness t_c [mm]	Pipe material / standard	Collar size (A_3)	No. of hooks	Classification
59	4.0	Pipe/hose for wood pellet transport, e.g. Pelletschlauch PVC NW51 of Erich Kuhn GmbH, Noviatox NW51 of Heizmann AG, PVC Saug- und Druckschlauch für Holzpellets of Haberkorn GmbH, RAUSPIRAFLEX pellet therm of Rehau AG, Pellet-Absaugschlauch PVC Sciroppo AS of CASTAN GmbH	CFS-C P 63/2"	3	EI 90-U/C

2.6.6 Plastic pipes with foamed elastomeric insulation according to Table 4 and Hilti Firestop Collar CFS-C P

Construction details

(for symbols and abbreviations see Annex 4):

For specification of the foamed elastomeric insulation material to be used see table 4.

Hilti Firestop Collar CFS-C P (A₃) is installed on the bottom side of the seal, fixed by threaded rods, washers and nuts as specified in Annex 1.2.

In some cases an additional protection is required:

AP₉: Mineral wool board according to table 1 installed around the pipe in the air gap between the two layers of the Hilti Firestop Double Board Seal.
Distance on all sides of the pipe 100 mm, depth 50 mm (height of the air gap).

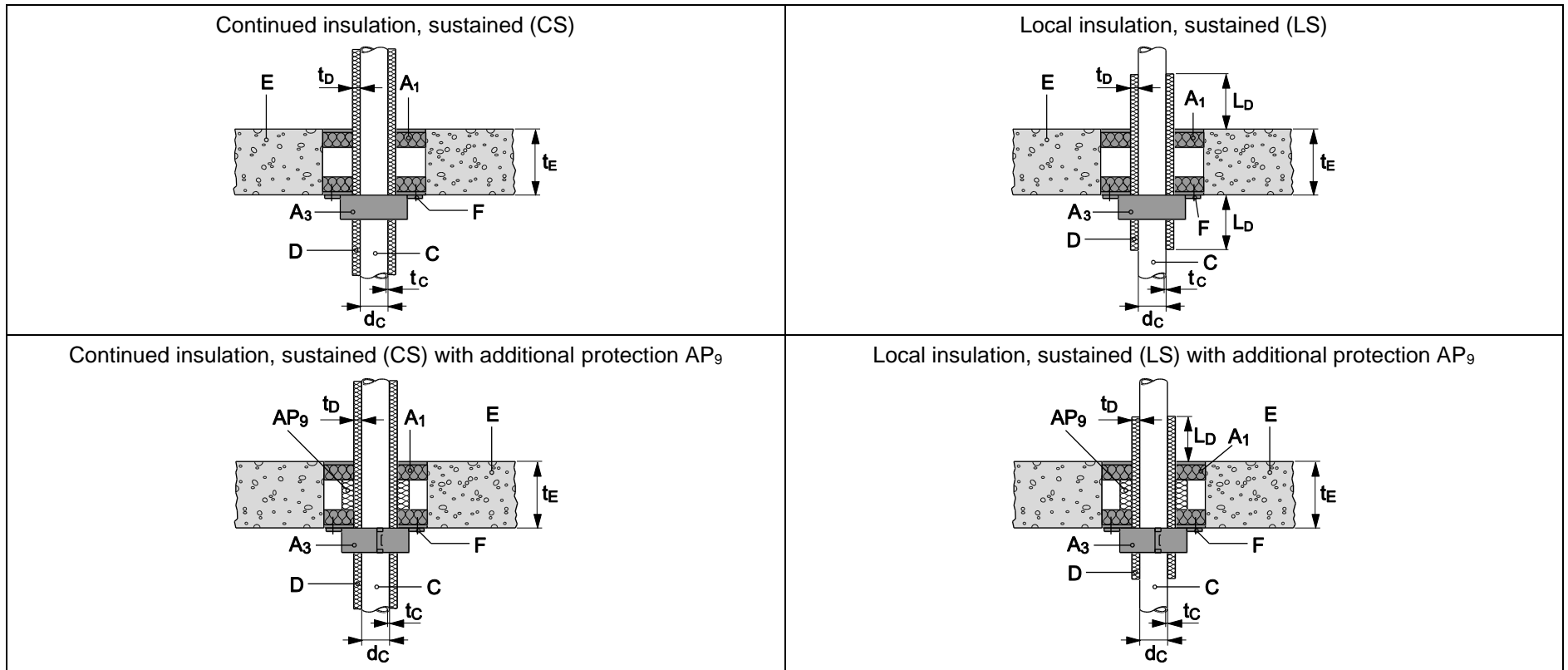

2.6.6.1 Pipes (C) with continued insulation (D) – sustained – U/C

2.6.6.1.1 PP pipes “Fusiotherm SDR 11”

Manufacturer: Aquatherm

Pipe		Insulation thickness (t_D) [mm]	Collar size (A_3)	No. of hooks	Classification	
diameter (d_c) [mm]	wall thickness (t_c) [mm]				-	AP ₉
Additional protection					-	AP ₉
40	3.7	9	CFS-C P 63/2"	2	-	EI 120-U/C

50	4.6	9	CFS-C P 75/2.5"	3	-	EI 120-U/C
75	6.8	10	CFS-C P 90/3"	3	-	EI 120-U/C
110	10.0	10	CFS-C P 125/5"	4	EI 90-U/C	EI 120-U/C
2.6.6.1.2 PP pipes "Fusiotherm Faser SDR 7.4/S3.2"						
Manufacturer: Aquatherm						
Pipe		Insulation	Collar size (A ₃)	No. of hooks	Classification	
diameter (d _c) [mm]	wall thickness (t _c) [mm]	thickness (t _D) [mm]				
Additional protection					-	AP ₉
40	5.5	9	CFS-C P 63/2"	2	-	EI 120-U/C
50	6.9	9	CFS-C P 63/2"	2	EI 90-U/C	-
50	6.9	9	CFS-C P 75/2.5"	3	-	EI 120-U/C
75	10.3	10	CFS-C P 90/3"	3	-	EI 120-U/C
110	15.1	10	CFS-C P 125/5"	4	-	EI 120-U/C
2.6.6.1.3 PE-100RC pipes "Wavin TS"						
Manufacturer: Wavin						
Pipe		Insulation	Collar size (A ₃)	No. of hooks	Classification	
diameter (d _c) [mm]	wall thickness (t _c) [mm]	thickness (t _D) [mm]				
Additional protection					-	AP ₉
50	4.6	9	CFS-C P 63/2"	2	-	EI 120-U/C
50	4.6	9	CFS-C P 75/2.5"	3	-	EI 120-U/C
63	5.8	10	CFS-C P 75/2.5"	3	-	EI 120-U/C
75	6.8	10	CFS-C P 90/3"	3	-	EI 120-U/C
90	8.2	10	CFS-C P 110/4"	4	EI 90-U/C	EI 120-U/C
110	10.0	10	CFS-C P 125/5"	4	-	EI 120-U/C
2.6.6.1.4 PE-Xa pipes "Rautitan flex"						
Manufacturer: Rehau						
Pipe		Insulation	Collar size (A ₃)		Classification	

diameter (d _c) [mm]	wall thickness (t _c) [mm]	thickness (t _D) [mm]		No. of hooks	
Additional protection					AP ₉
16	2.2	8	CFS-C P 50/1.5"	2	EI 120-U/C
16	2.2	32	CFS-C P 90/3"	3	EI 120-U/C
32	4.4	9	CFS-C P 50/1.5"	2	EI 120-U/C
32	4.4	35	CFS-C P 110/4"	4	EI 120-U/C
40	5.5	9	CFS-C P 63/2"	2	EI 120-U/C
40	5.5	20.5	CFS-C P 75/2.5"	3	EI 120-U/C
50	6.9	9	CFS-C P 75/2.5"	2	EI 120-U/C
50	6.9	21	CFS-C P 90/3"	3	EI 120-U/C
63	8.6	9	CFS-C P 90/3"	3	EI 120-U/C
63	8.6	21.5	CFS-C P 110/4"	4	EI 120-U/C

2.6.6.1.5 PP pipes “Climatherm Faserverbundrohr”					
Manufacturer: Aquatherm					
Pipe		Insulation	Collar size (A ₃)	No. of hooks	Classification
diameter (d _c) [mm]	wall thickness (t _c) [mm]	thickness (t _D) [mm]			
			Additional protection		AP ₉
75	6.8	10	CFS-C P 90/3”	3	EI 120-U/C
2.6.6.1.6 PP pipes “Firestop”					
Manufacturer: Aquatherm					
Pipe		Insulation	Collar size (A ₃)	No. of hooks	Classification
diameter (d _c) [mm]	wall thickness (t _c) [mm]	thickness (t _D) [mm]			
			Additional protection		AP ₉
90	12.3	22.5	CFS-C P 160/6”	4	EI 120-U/C
110	15.1	10	CFS-C P 125/5”	4	EI 120-U/C
2.6.6.1.7 PVC-C pipes “Friatherm starr”					
Manufacturer: Friatec					
Pipe		Insulation	Collar size (A ₃)	No. of hooks	Classification
diameter (d _c) [mm]	wall thickness (t _c) [mm]	thickness (t _D) [mm]			
			Additional protection		AP ₉
32	3.6	9	CFS-C P 50/1.5”	2	EI 120-U/C
40	4.5	9	CFS-C P 50/1.5”	2	EI 120-U/C
50	5.6	9	CFS-C P 75/2.5”	3	EI 120-U/C
63	7.1	9	CFS-C P 110/4”	4	EI 120-U/C

2.6.6.2 Pipes (C) with local insulation (D) – sustained – U/C

2.6.6.2.1 PP pipes “Fusiotherm SDR 11”

Manufacturer: Aquatherm

Pipe		Insulation		Collar size (A ₃)	No. of hooks	Classification	
diameter (d _c) [mm]	wall thickness (t _c) [mm]	thickness (t _D) [mm]	length (L _D) [mm]				
Additional protection						-	AP ₉
40	3.7	9	≥200	CFS-C P 63/2”	2	-	EI 120-U/C
50	4.6	9	≥200	CFS-C P 75/2.5”	3	-	EI 120-U/C
75	6.8	10	≥200	CFS-C P 90/3”	3	-	EI 120-U/C
110	10.0	10	≥250	CFS-C P 125/5”	4	EI 90-U/C	-
110	10.0	10	≥200	CFS-C P 125/5”	4	-	EI 120-U/C

2.6.6.2.2 PP pipes “Fusiotherm Faser SDR 7.4/S3.2”

Manufacturer: Aquatherm

Pipe		Insulation		Collar size (A ₃)	No. of hooks	Classification	
diameter (d _c) [mm]	wall thickness (t _c) [mm]	thickness (t _D) [mm]	length (L _D) [mm]				
Additional protection						-	AP ₉
40	5.5	9	≥200	CFS-C P 63/2”	2	-	EI 120-U/C
50	6.9	9	≥250	CFS-C P 63/2”	2	EI 90-U/C	-
50	6.9	9	≥200	CFS-C P 75/2.5”	3	-	EI 120-U/C
75	10.3	10	≥200	CFS-C P 90/3”	3	-	EI 120-U/C
110	15.1	10	≥200	CFS-C P 125/5”	4	-	EI 120-U/C

2.6.6.2.3 PE-100RC pipes “Wavin TS”

Manufacturer: Wavin

Pipe		Insulation		Collar size (A ₃)	No. of hooks	Classification	
diameter (d _c) [mm]	wall thickness (t _c) [mm]	thickness (t _D) [mm]	length (L _D) [mm]				
Additional protection						-	AP ₉
50	4.6	9	≥200	CFS-C P 63/2”	2	-	EI 120-U/C
50	4.6	9	≥200	CFS-C P 75/2.5”	3	-	EI 120-U/C
63	5.8	10	≥200	CFS-C P 75/2.5”	3	-	EI 120-U/C
75	6.8	10	≥200	CFS-C P 90/3”	3	-	EI 120-U/C
90	8.2	10	≥250	CFS-C P 110/4”	4	EI 90-U/C	-
90	8.2	10	≥200	CFS-C P 110/4”	4	-	EI 120-U/C
110	10.0	10	≥200	CFS-C P 125/5”	4	-	EI 120-U/C

2.6.6.2.4 PE-Xa pipes “Rautitan flex”

Manufacturer: Rehau

Pipe		Insulation		Collar size (A ₃)	No. of hooks	Classification	
diameter (d _c) [mm]	wall thickness (t _c) [mm]	thickness (t _D) [mm]	length (L _D) [mm]				
Additional protection						AP ₉	
40	5.5	9	≥200	CFS-C P 63/2”	2	EI 120-U/C	
40	5.5	20.5	≥250	CFS-C P 75/2.5”	3	EI 120-U/C	
50	6.9	9	≥200	CFS-C P 75/2.5”	3	EI 120-U/C	
50	6.9	21	≥250	CFS-C P 90/3”	3	EI 120-U/C	
63	8.6	9	≥200	CFS-C P 90/3”	3	EI 120-U/C	
63	8.6	21.5	≥250	CFS-C P 110/4”	4	EI 120-U/C	

2.6.6.2.5 PP pipes "Climatherm Faserverbundrohr"						
Manufacturer: Aquatherm						
Pipe		Insulation		Collar size (A ₃)	No. of hooks	Classification
diameter (d _c) [mm]	wall thickness (t _c) [mm]	thickness (t _D) [mm]	length (L _D) [mm]			
				Additional protection		AP ₉
75	6.8	10	≥200	CFS-C P 90/3"	3	EI 120-U/C
2.6.6.2.6 PP pipes "Firestop"						
Manufacturer: Aquatherm						
Pipe		Insulation		Collar size (A ₃)	No. of hooks	Classification
diameter (d _c) [mm]	wall thickness (t _c) [mm]	thickness (t _D) [mm]	length (L _D) [mm]			
				Additional protection		AP ₉
90	12.3	22.5	≥250	CFS-C P 160/6"	4	EI 120-U/C
110	15.1	10	≥200	CFS-C P 125/5"	4	EI 120-U/C
2.6.6.2.7 PVC-C pipes "Friatherm starr"						
Manufacturer: Friatec						
Pipe		Insulation		Collar size (A ₃)	No. of hooks	Classification
diameter (d _c) [mm]	wall thickness (t _c) [mm]	thickness (t _D) [mm]	length (L _D) [mm]			
				Additional protection		AP ₉
32	3.6	9	≥200	CFS-C P 50/1.5"	2	EI 120-U/C
40	4.5	9	≥200	CFS-C P 50/1.5"	2	EI 120-U/C
50	5.6	9	≥200	CFS-C P 75/2.5"	3	EI 120-U/C
63	7.1	9	≥200	CFS-C P 110/4"	4	EI 120-U/C

2.6.7 Plastic pipes with Hilti Firestop Collar CFS-C

Construction details

(for symbols and abbreviations see Annex 4):

Hilti Firestop Collar CFS-C (A₃) is installed on the bottom side of the seal, fixed by threaded rods, washers and nuts as specified in Annex 1.2.

No additional protection.

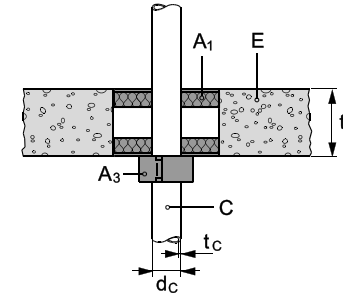

2.6.7.1 PVC-U pipes (C) according to EN ISO 1452-2, EN ISO 15493, DIN 8061/8062 – U/C

Pipe diameter (d _c) [mm]	Pipe wall thickness (t _{c1}) [mm]	Collar size (A ₃)	No. of hooks	Classification
32	1.9	CFS-C 50/1.5"	2	EI 120-U/C
110	2.2 – 8.2	CFS-C 110/4"	4	EI 120-U/C
160	4.7	CFS-C 160/6"	5	EI 90-U/C

The results are also valid for PVC-U pipes according EN 1329-1¹⁶ and EN 1453-1¹⁷ and PVC-C pipes according EN 1566-1

2.6.7.2 PE pipes (C) according to EN ISO 15494, DIN 8074/8075

Pipe diameter (d _c) [mm]	Pipe wall thickness t _c [mm]	Collar size (A ₃)	No. of hooks	Classification
50	3.0	CFS-C 50/1.5"	2	EI 90-U/C
63	2.0	CFS-C 63/2"	2	EI 90-U/C

2.6.7.3 PE-100 pipes, EN 12666 , Geberit Silent dB20

Pipe diameter (d _c) [mm]	Pipe wall thickness t _c [mm]	Collar size (A ₃)	No. of hooks	Classification
110	4,2	CFS-C 110/4"	4	EI 120-U/C
160	6,2	CFS-C 160/6"	4	EI 120-U/C

2.6.7.4 PP-R pipes , „Aquatherm Green”, acc. EN 15874 and DIN 8077/78, with additional protection AP9 see 2.6.5 and 2.6.6, offset = 80mm

Pipe diameter (d _c) [mm]	Pipe wall thickness t _c [mm]	Collar size (A ₃)	No. of hooks	Classification
110	10	CFS-C 110/4”	4	EI 120-U/C

2.6.7.5 PP-R pipes , „Aquatherm Blue”, acc. EN 15874 and DIN 8077/78, with additional protection AP9 see 2.6.5 and 2.6.6, offset = 80mm

Pipe diameter (d _c) [mm]	Pipe wall thickness t _c [mm]	Collar size (A ₃)	No. of hooks	Classification
160	14,6	CFS-C 160/6”	4	EI 120-U/C

2.6.7.6 PVC-U pipes , Georg Fischer “Dekadur” acc. DIN 8061/62, with additional protection AP9 see 2.6.5 and 2.6.6, offset = 80mm

Pipe diameter (d _c) [mm]	Pipe wall thickness t _c [mm]	Collar size (A ₃)	No. of hooks	Classification
160	4,7	CFS-C 160/6”	4	EI 120-U/C

2.6.8.1 PE pipes acc. EN 1519-1, EN12201-2 and EN 12666-1 and ABS-pipes acc. EN 1455-1 and SAN+PVC-pipes acc. EN 1565-1

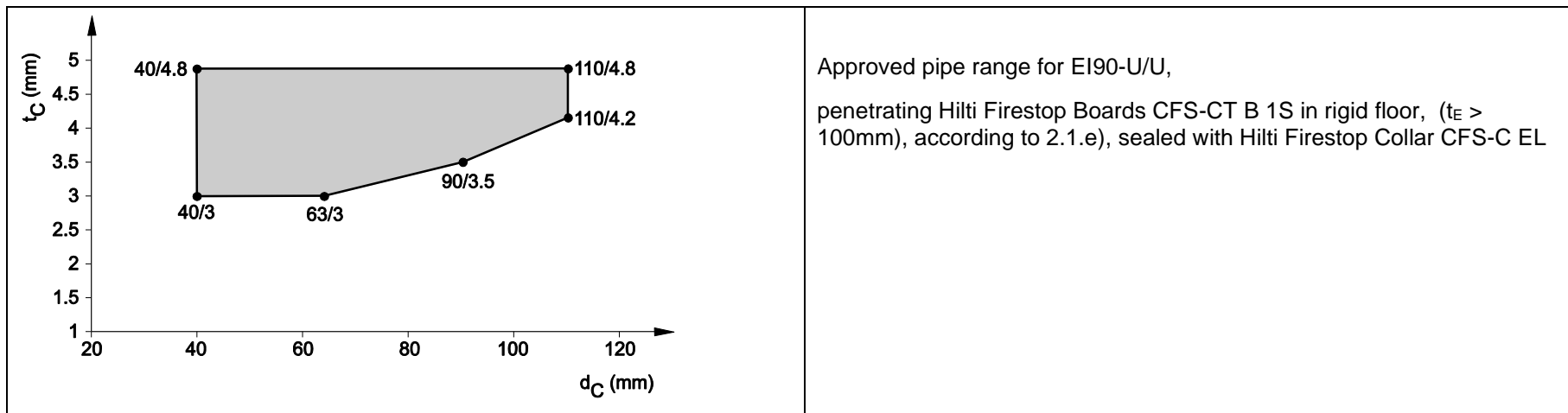

2.6.8.2 ABS pipes acc. EN 1455-1, EN 15493 and SAN+PVC-pipes acc. EN 1565-1

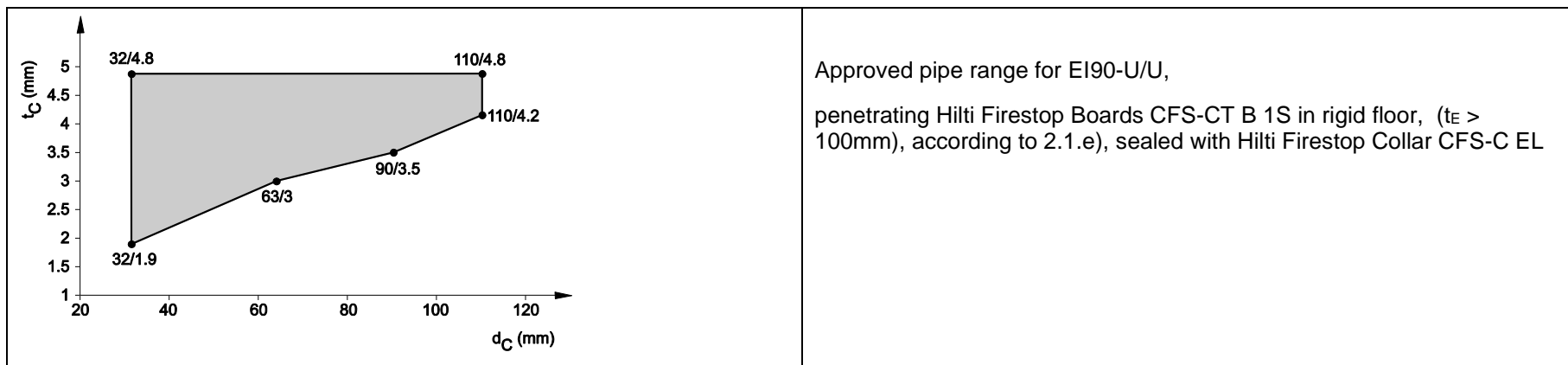

2.6.8.3 PE pipes acc. EN 15494, EN12201-2 and DIN 8074/75

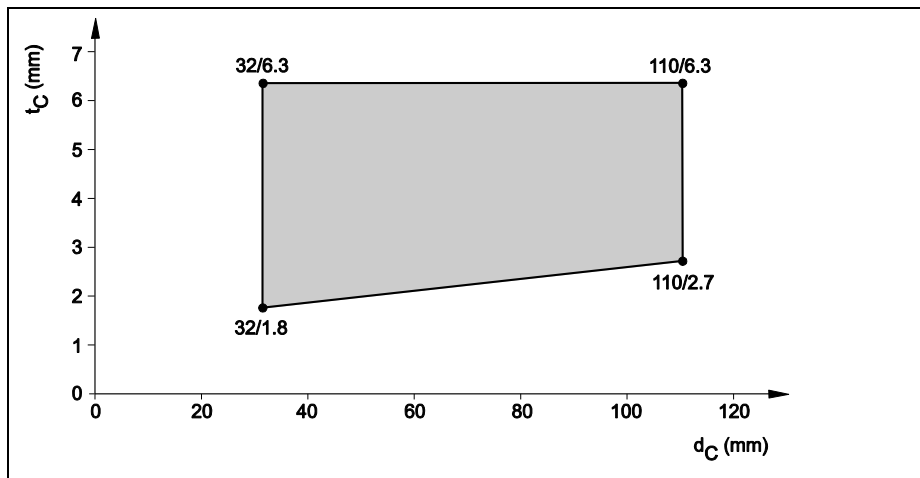

Approved pipe range for EI90-U/U,
penetrating Hilti Firestop Boards CFS-CT B 1S in rigid floor, ($t_E > 150\text{mm}$), according to 2.1.e), sealed with Hilti Firestop Collar CFS-C EL

2.6.8.4 PVC pipes acc. EN 1452-1, EN1329-1, EN1453-1, EN 1566-1, EN ISO 15493 and DIN 8061/62

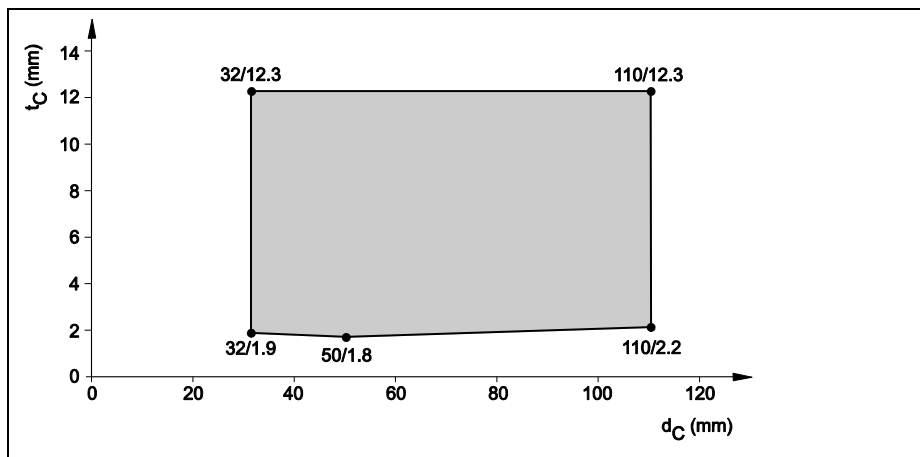

Approved pipe range for EI90-U/U,
penetrating Hilti Firestop Boards CFS-CT B 1S in rigid floor, ($t_E > 150\text{mm}$), according to 2.1.e), sealed with Hilti Firestop Collar CFS-C EL

2.6.8.5 PP pipes, non-regulated

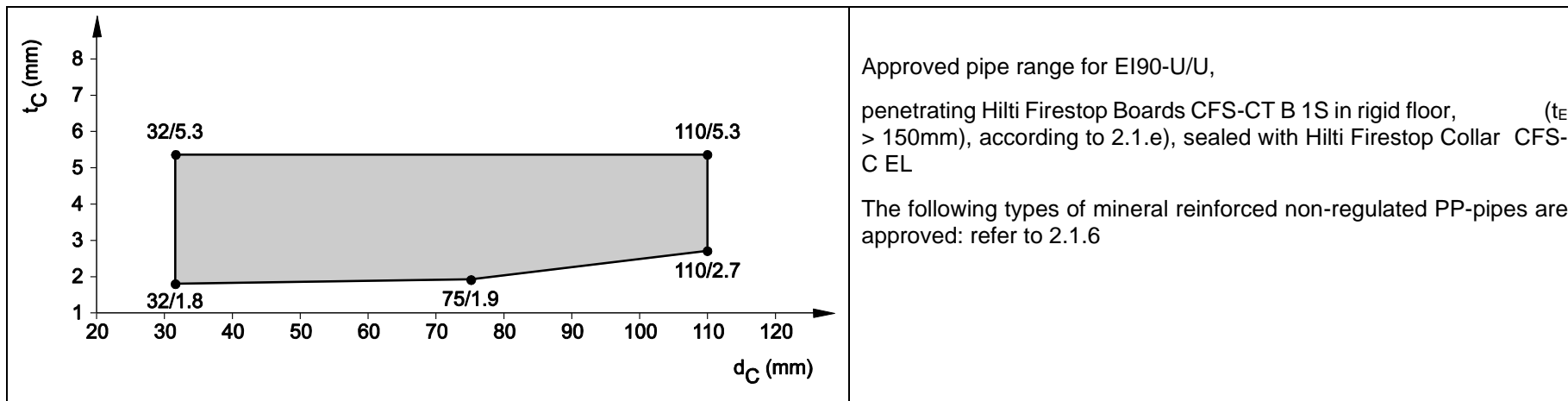

2.6.8.6 PP pipes acc. EN 1451-1 and DIN 8077/78

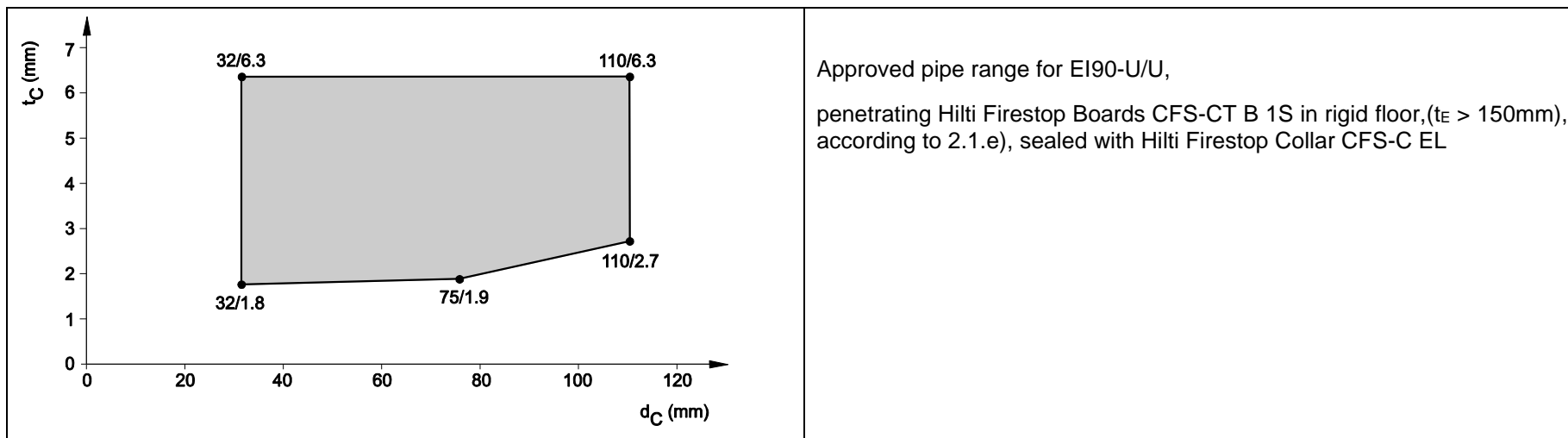

2.6.8.7 PE pipes, non-regulated (Geberit Silent dB20)

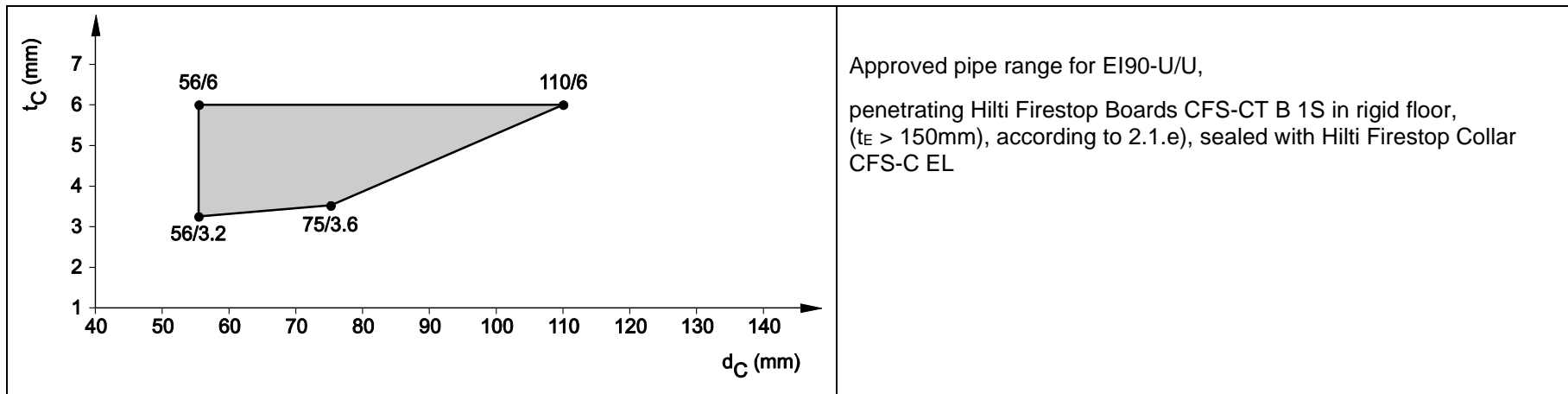

2.6.8.8 PVC-pipes, non-regulated (Friatec Friaphon)

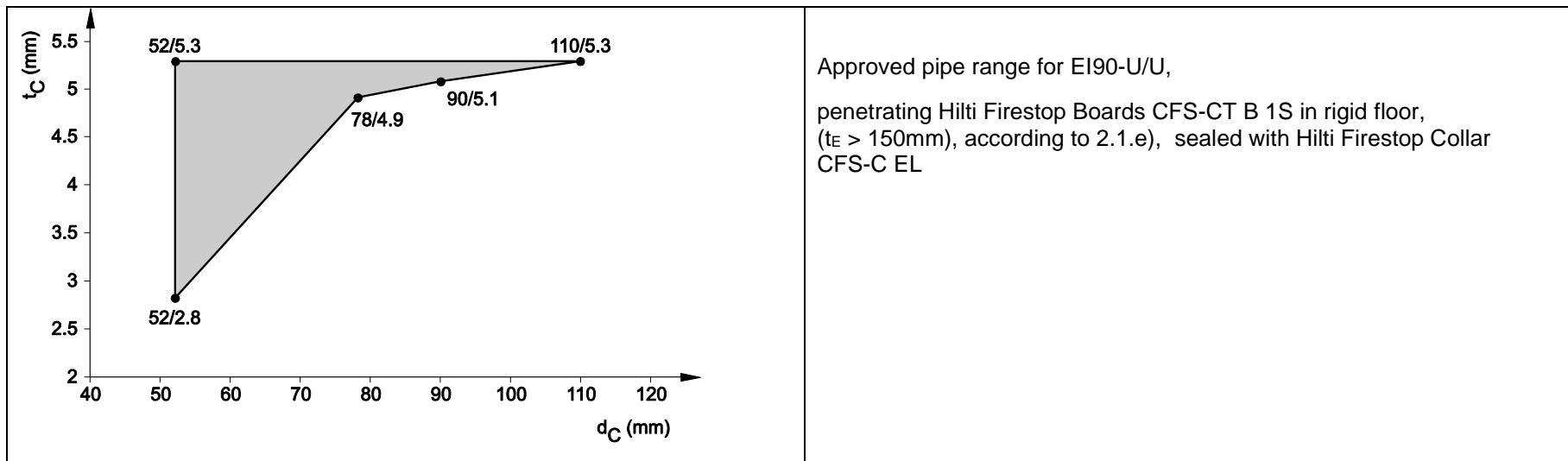

2.6.9 Plastic pipes with Hilti Firestop Wrap CFS-W

Construction details

(for symbols and abbreviations see Annex 4):

Hilti Firestop Wrap CFS-W EL or SG (A_4) is wrapped around the pipe on bottom side of the seal and positioned within the annular gap so that the outer edge of the wrap is flush with the surface of the floor as specified in Annex 1.2.

In some cases an additional protection is required:

AP_9 : Mineral wool board according to Table installed around the pipe in the air gap between the two boards of the Hilti Firestop Double Board Seal.
Width around the pipe 100 mm,
thickness 50 mm (height of the air gap).

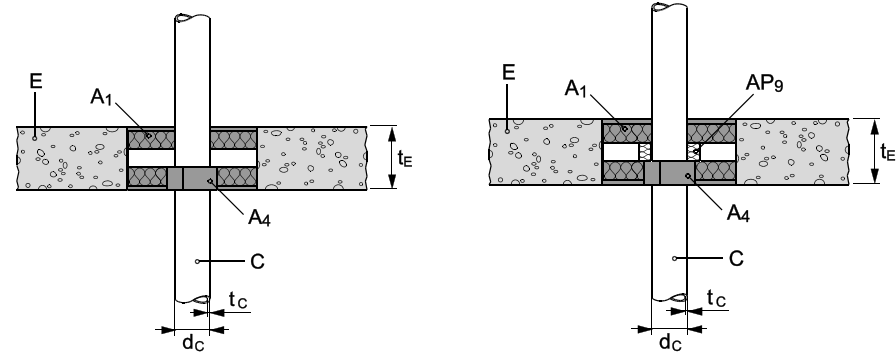

2.6.9.1 PVC-U pipes with Hilti Firestop Wrap CFS-W

PVC-U pipes (C) according to EN ISO 1452-2, EN ISO 15493, DIN 8061/8062 – U/C

Pipe diameter (d_c) [mm]	Pipe wall thickness t_c [mm]	Wrap type (A_4)	Size (CFS-W SG) No. of layers (CFS-W EL)	Classification
Additional protection				-
75	3.6	CFS-W SG	75/2.5"	EI 90-U/C
125	6.0	CFS-W SG	125/5"	EI 90-U/C

The results are also valid for PVC-U pipes according EN 1329-1¹⁶ and EN 1453-1¹⁷ and PVC-C pipes according EN 1566-1.

PVC-U pipes (C) according to EN ISO 1452-2, EN ISO 15493, DIN 8061/8062 – C/U

Pipe diameter (d_c) [mm]	Pipe wall thickness t_c [mm]	Wrap type (A_4)	Size (CFS-W SG) No. of layers (CFS-W EL)	Classification
Additional protection				AP_9
≤ 75	2.2 – 5.6	CFS-W EL	2	EI 60-C/U
≤ 75	5.6	CFS-W EL	2	EI 90-C/U

PVC-U pipes, Georg Fischer "Dekadur", DIN 8061/62

with additional protection AP9 see 2.6.5 and 2.6.6, offset = 80mm

Pipe diameter (d _c) [mm]	Pipe wall thickness t _c [mm]	Wrap type (A ₄)	Size (CFS-W SG) No. of layers (CFS-W EL)	Classification
110	3,2	CFS-W EL	2	EI 120-U/C
160	4,7	CFS-W EL	3	EI 120-U/C

>75 ≤ 110	2.2 – 8.1	CFS-W EL	2	EI 60-C/U
The results are also valid for PVC-U pipes according EN 1329-1 ¹⁶ and EN 1453-1 ¹⁷ and PVC-C pipes according EN 1566-1.				

2.6.9.2 PE pipes with Hilti Firestop Wrap CFS-W

2.6.8.2.1 PE pipes (C) according to EN 1519¹⁸ - U/C Additional protection AP₉

Pipe diameter (d _c) [mm]	Pipe wall thickness t _c [mm]	Wrap type (A ₄)	Size (CFS-W SG) No. of layers (CFS-W EL)	Classification
75	3.0	CFS-W SG	75/2.5"	EI 90-U/C
≤75	3.0	CFS-W EL	2	EI 60-C/U

The results are also valid for PE pipes according to EN 12201-2 and EN 12666-1.

2.6.8.2.2 PE pipes (C) according to EN ISO 15494, DIN 8074/8075 – U/U , Additional protection, AP₉

Pipe diameter (d _c) [mm]	Pipe wall thickness t _c [mm]	Wrap type (A ₄)	Size (CFS-W SG) No. of layers (CFS-W EL)	Classification
≤125	3.1	CFS-W EL	2	EI 60-U/U

PE pipes (C) according to EN ISO 15494, DIN 8074/8075 – U/C; Additional protection, AP₉

Pipe diameter (d _c) [mm]	Pipe wall thickness t _c [mm]	Wrap type (A ₄)	Size (CFS-W SG) No. of layers (CFS-W EL)	Classification
75	1.9	CFS-W SG	75/2.5"	EI 90-U/C
110	2.7	CFS-W SG	110/4"	EI 90-U/C
125	7.1	CFS-W SG	125/5"	EI 90-U/C

PE pipes (C) according to EN ISO 15494, DIN 8074/8075 – C/U, Additional protection, AP₉

Pipe diameter (d _c) [mm]	Pipe wall thickness t _c [mm]	Wrap type (A ₄)	Size (CFS-W SG) No. of layers (CFS-W EL)	Classification
≤75	4.3	CFS-W EL	2	EI 60-C/U

2.6.8.2.3 PE-S2 pipes “Geberit Silent-db20”

Manufacturer: Geberit Int. with additional protection AP9 see 2.6.5 and 2.6.6, offset = 80mm

Pipe diameter (d _c) [mm]	Pipe wall thickness t _c [mm]	Wrap type (A ₄)	Size (CFS-W SG) No. of layers (CFS-W EL)	Classification
≤75	3.6	CFS-W EL	2	EI 120-C/U
110	4,2	CFS-W EL	2	EI 120-U/C
160	6,2	CFS-W EL	3	EI 120-U/C

2.6.9.3 PP pipes according EN 1451-1 with Hilti Firestop Wrap CFS-W – C/U**2.6.8.3.1 PP pipes “Wavin AS” or “Phonex AS”**

Manufacturer: Wavin Ireland Ltd or KeKelit, Additional protection AP₉

Pipe diameter (d _c) [mm]	Pipe wall thickness t _c [mm]	Wrap type (A ₄)	Size (CFS-W SG) No. of layers (CFS-W EL)	Classification
≤70	4.5	CFS-W EL	2	EI 120-C/U

2.6.8.3.2 PP/PP-MV/PP pipes “Polokal NG”

Manufacturer: Poloplast. Additional protection AP₉

Pipe diameter (d _c) [mm]	Pipe wall thickness t _c [mm]	Wrap type (A ₄)	Size (CFS-W SG) No. of layers (CFS-W EL)	Classification
≤75	2.6	CFS-W EL	2	EI 120-C/U

2.6.8.3.3 PP/Porolen/PP pipes “Polokal 3S”

Manufacturer: Poloplast. Additional protection AP₉

Pipe diameter (d _c) [mm]	Pipe wall thickness t _c [mm]	Wrap type (A ₄)	Size (CFS-W SG) No. of layers (CFS-W EL)	Classification
≤75	3.8	CFS-W EL	2	EI 120-C/U
>75 ≤ 110	4.8	CFS-W EL	2	EI 120-C/U

2.6.8.3.4 PP-R pipes “Aquatherm Green pipe”

with additional protection AP9 see 2.6.5 and 2.6.6, offset = 80mm

Pipe diameter (d _c) [mm]	Pipe wall thickness t _c [mm]	Wrap type (A ₄)	Size (CFS-W SG) No. of layers (CFS-W EL)	Classification
110	10,0	CFS-W EL	2	EI 120-U/C

2.6.10 Plastic pipes with Hilti Firestop Wrap CFS-W P in rigid floor

Rigid floors acc. 2.1g):

The floor must have a minimum thickness of 150 mm and comprise aerated concrete or concrete with a minimum density of 450 kg/m³.

Hilti Firestop Wrap CFS-W P (A₁) to be mounted on soffit of the Hilti Firestop Double Board Seal CFS-CT for seal design type i) and ii) see 2.6.10.1.. In case of seal design type iii), iv) and v) (refer to 2.6.10.1) the Hilti Firestop Wrap CFS-W P has to be installed from bottom and top side.

The bottom side wrap comes 5 mm further than the bottom surface of the board seal, and on top side the Hilti Firestop Wrap CFS-W P has to be installed flush with the top surface of the board seal.

Annular gap between the pipe sealing and the double board sealed with Hilti Firestop Acrylic Sealant CFS-S ACR – material (A₆): water based acrylic sealant.

The boards are placed into the opening of the floor construction. They are placed against each other and installed flush with the floor surface at the top side only.

Hilti Firestop Wrap CFS-W P is a graphite based strip with a width of 50mm and a thickness of 2mm. Used length depends from pipe diameter, insulation and construction group (CG).

The Hilti Firestop Wrap CFS-W P in floor installation is supported by Z-profiles (F) made of steel plate with a thickness from 0,5 mm and a width of 20 mm. The Z-profiles are constructed with a horizontal part of 70mm and 10mm and a vertical part of 55mm. Z-profiles (F) support the lower wrap only. The upper one – if installed – has not to be supported.

Number of Z-profiles:

Construction	Pipe material	Pipe diameter	Position of wrap CFS-W P	Number of Z-profiles	Position of Z-profiles
Floor	Plastic	≤ 75 (mm)	At the bottom side if the floor	2	Installed in the bottom board position, holding the pipe sealing and at the other side located on the top surface of the lowest board, under the upper board
		> 75 (mm)		3	
	- Aluminium composite, - Steel, - Copper	All approved diameter	At the bottom and upper side of the floor	without	n.a.

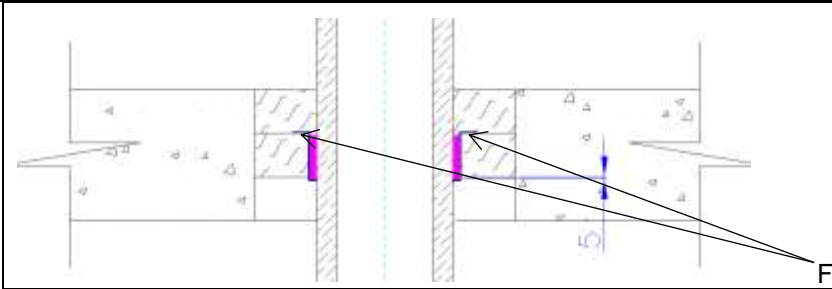

Hilti CFS-CT Double board seal, penetrated with a plastic pipe according to 2.6.10.5, sealed with Hilti Firestop Wrap CFS-W P. If the floor thickness is bigger than 100mm, so boards are installed in direct contact to each other, flush with the upper floor surface only.

Z-profile is shown to be installed in between both boards, supporting the wrap. The wrap comes 5mm out of the seal on soffit side only.

Pipes have to be supported on upside only, maximum 250mm above floor level.

2.6.10.1 Pipes, sealed with Hilti Firestop Wrap CFS-W P – seal design variations in floor

Seal design type		Sealing product (A ₁)		Annular sealing (A ₂)	Principle drawings
i)	Uninsulated Plastic Pipe	CFS-W P	Standard number of layers	Acrylic sealant CFS-S ACR	
ii)	Insulated Plastic Pipe	CFS-W P	Standard number of layers	Acrylic sealant CFS-S ACR	

iii)	Insulated (CS) Aluminium composite Pipe	CFS-W P	Standard number of layers	Acrylic sealant CFS-S ACR	
iv)	Insulated (CS) Metal Pipe	CFS-W P	Standard number of layers	Acrylic sealant CFS-S ACR	

V)	Insulated (CS) Metal Pipe with add. protection D_2 (200 mm)	CFS-W P	Standard number of layers	Acrylic sealant CFS-S ACR	
----	---	---------	---------------------------	---------------------------	--

2.6.10.2 Pipe insulation

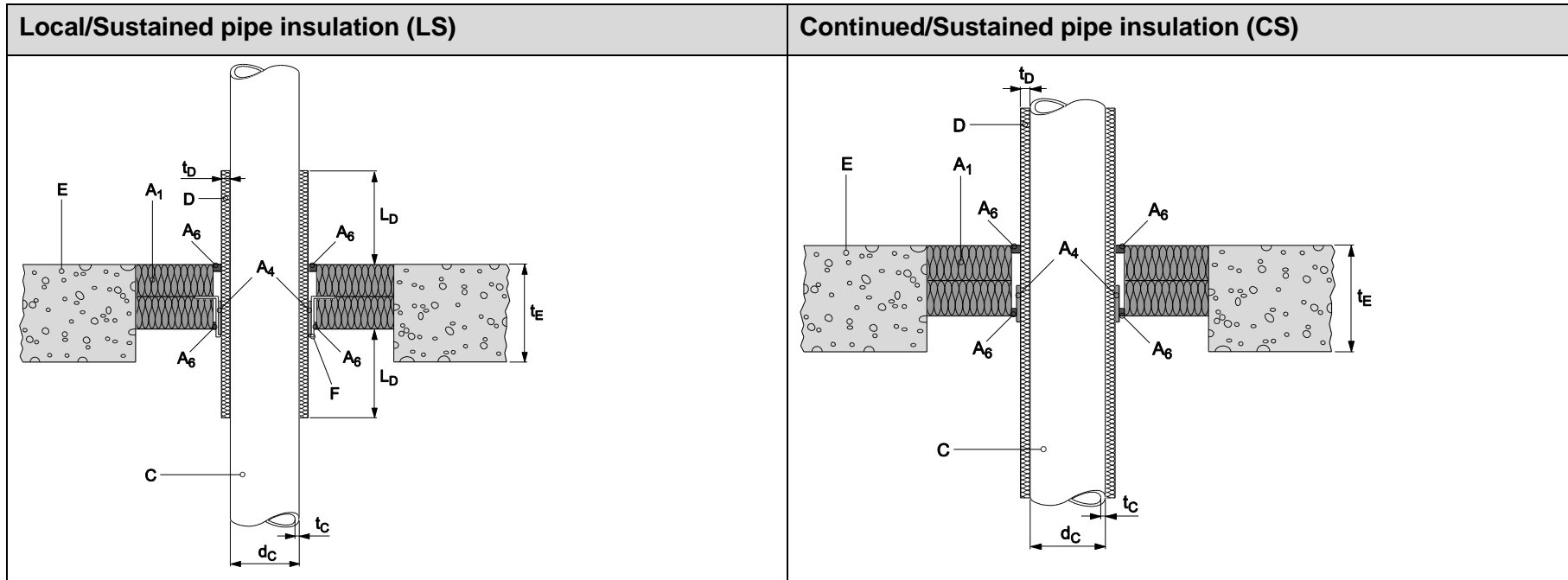

2.6.10.3 Layer groups

There are several layer groups which defines the number of layers of the Hilti Firestop Wrap CFS-W P. The number of specific construction group (CG) = layer group relates always to the number of used layers of CFS-W P. (For instance; construction group 4 means always 4 wrapped layers of CFS-W P.)

Plastic pipes:

Layer group	Diameter range (mm)	Number of layers
2	32 – 56	2
3	63 – 75	3
4	90 – 125	4
5*	90 – 110	5
6	>135 – 160	6

* This construction group is only used for PE-pipes provided with Elastomeric insulation

Aluminium composite pipes:

If the pipe is used in a U/C pipe end configuration, following number of layers is to apply.

Layer group	Diameter range (mm)	Number of layers
1	16 to 40	1
2	56 to 75	2

Metal pipes:

If the pipe is used in a C/U pipe end configuration, following number of layers is to apply.

Layer group	Diameter range (mm)	Number of layers
1	10 to 42	1
2	> 42 to 114	2
3	> 114 to 219	3

2.6.10.4 Separation of penetrations

For separations a_2 - a_3 , please refer to the following clauses. General distance rules given in 2.2 are not valid for chapters 2.6.10, 2.6.11 and 2.6.12 (and their sub-chapters)

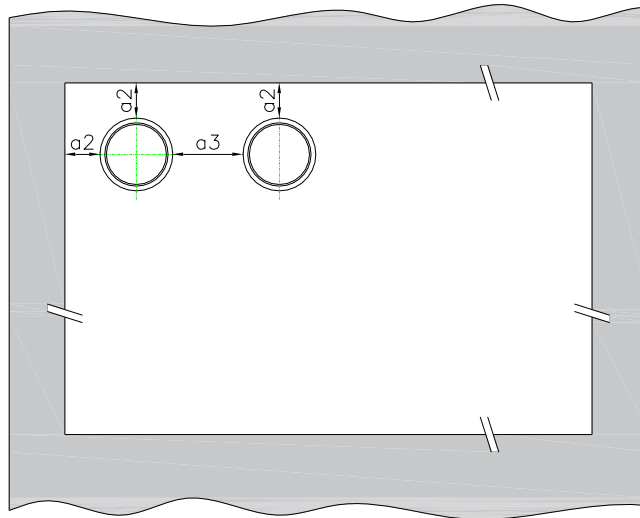

(View from above)

2.6.10.5 Plastic pipes sealed with Hilti Firestop Wrap CFS-W P penetrating a double board seal CFS-CT

2.6.10.5.1 PE - pipes according to EN 1519-1, EN 12666-1, EN 12201-2 for EI 90-U/U

PE pipes according to EN 1519-1, EN 12666-1, EN 12201-2, Seal design: i) according to 2.2.14.1					
Layers	Pipe diameter dc Ø (mm)	Pipe wall thickness tc (mm)	Separation a2 (mm)	Separation a3 (mm)	Classification
2	32 to 56	3,0	25	50	EI 90-U/U, E 90-U/U
3	> 56 to 75	3,0	25	50	
4	> 75 to 125	3,5 to 4,9	25	50	
6	> 125 to 160	6,2	25	50	

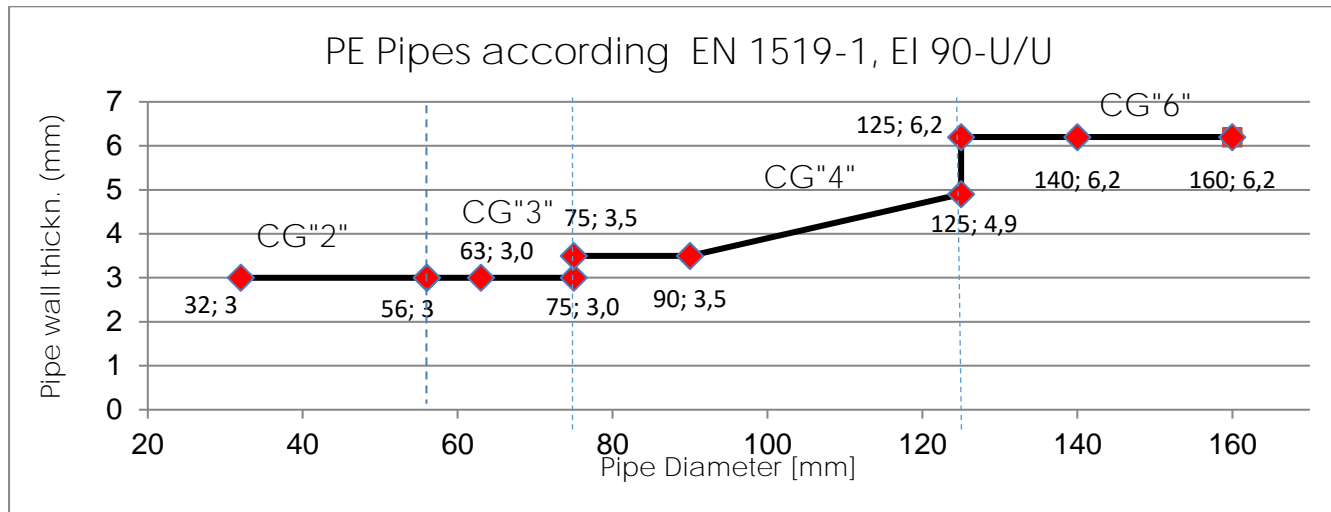

2.6.10.5.2 PE - pipes according to EN 1519-1, EN 12666-1, EN 12201-2 for EI 120-U/U

For EI 120-U/U: PE pipes according to EN 1519-1, EN 12666-1, EN 12201-2, Seal design: i) according to 2.2.14.1					
Layers	Pipe diameter d_c \varnothing (mm)	Pipe wall thickness t_c (mm)	Separation a_2 (mm)	Separation a_3 (mm)	Classification
2	32 to 56	3,0	50	100	EI 120-U/U, E 120-U/U
3	> 56 to 75	3,0	50	100	
4	> 75 to 90	3,5	50	100	
6	125 to 160	6,2	50	100	

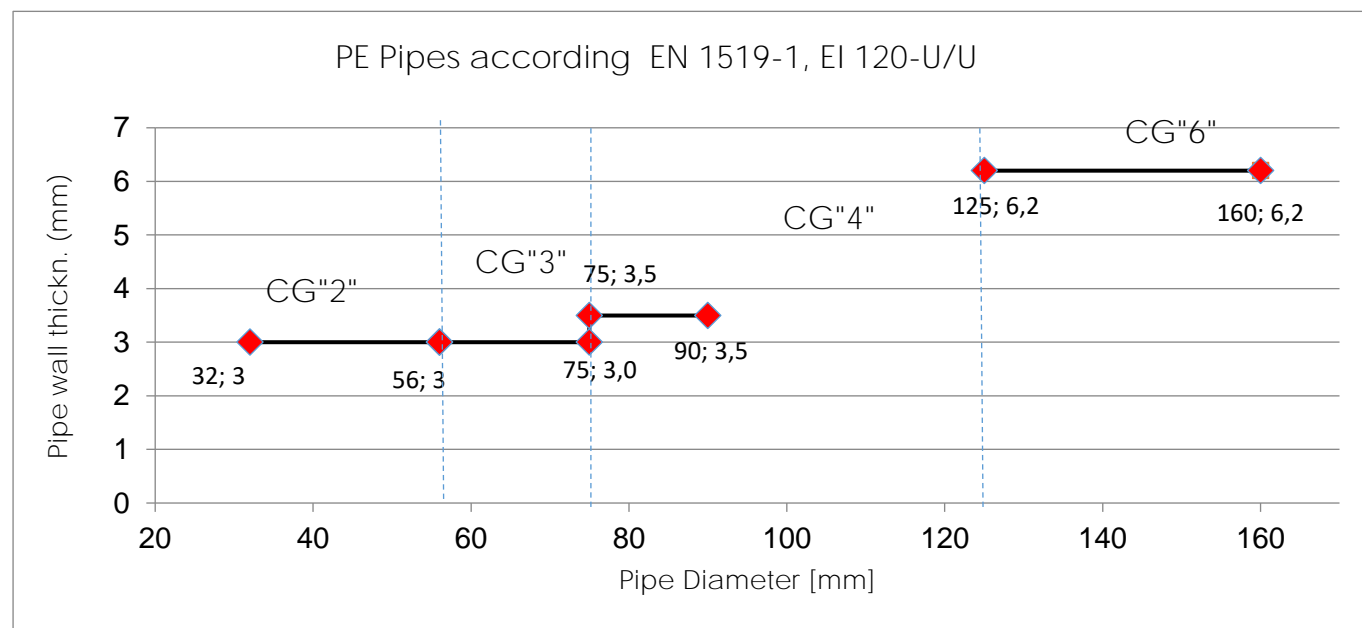

2.6.10.5.3 PE - pipes (isolated) according to EN 1519-1, EN 12666-1, EN 12201-2 for EI 90-U/U

PE pipes according to EN 1519-1, EN 12666-1, EN 12201-2, Seal design: ii) according to 2.2.14.1 Elastomeric insulation: refer to Annex 1 - 1.2.12 table 4						
Layers	Pipe diameter d_c \varnothing (mm)	Pipe wall thickness t_c (mm)	Pipe insulation thickness (mm)	Separation a_2 (mm)	Separation a_3 (mm)	Classification
2	32 - 56	3,0	9,0 to 21,5	25	50	EI 90-U/U, E 90-U/U
4	> 56 - 75	3,0	9,0/9,5 to 21,5/22,0	25	50	
5	> 75 - 90	3,0 to 3,5	9,5 to 23,0	25	50	

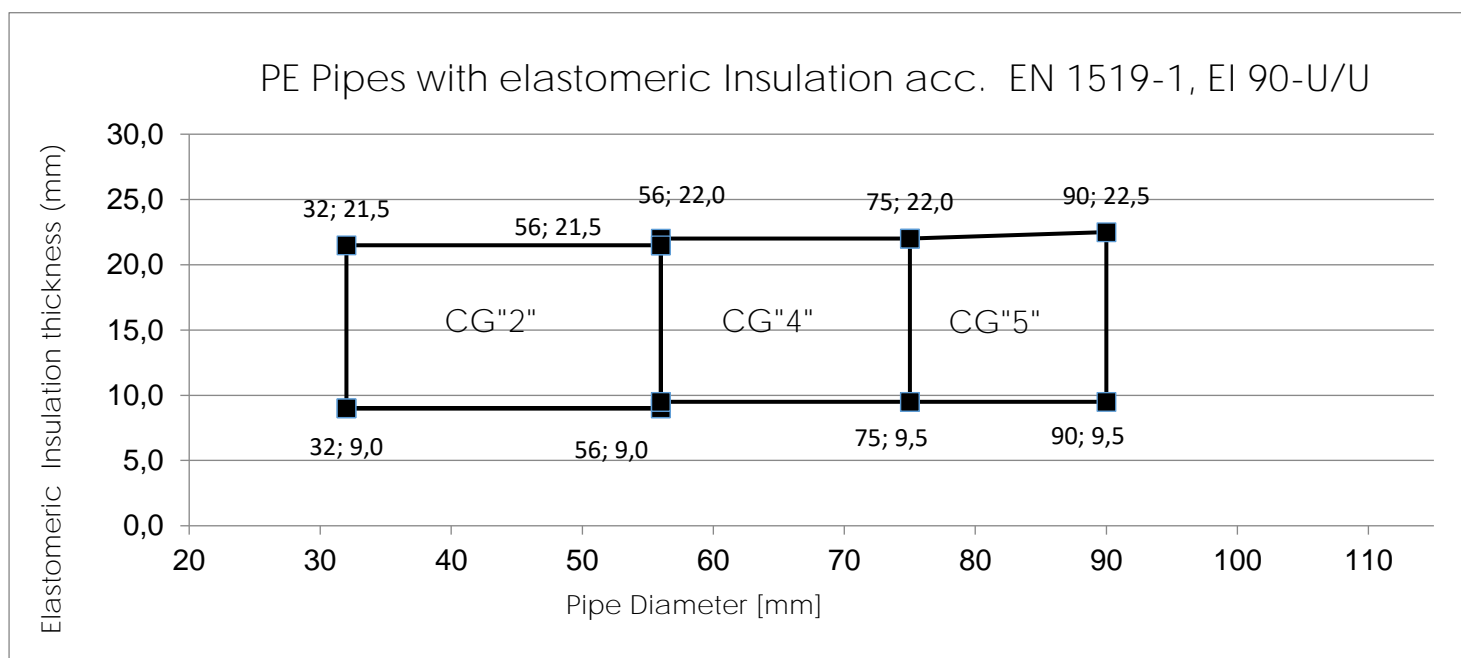

2.6.10.5.4 PE – pipes (Geberit Silent dB20) for EI 90-U/U

PE pipes, designation Geberit Silent dB20, Seal design: i) according to 2.2.14.1					
Layers	Pipe diameter d_c Ø (mm)	Pipe wall thickness t_c (mm)	Separation a_2 (mm)	Separation a_3 (mm)	Classification
2	56	3,2	25	50	EI 90-U/U, E 120-U/U
3	> 56 to 75	3,2 to 3,6	25	50	
4	> 75 to 110	3,6 to 6,0	25	50	
6	> 110 to 160	6,0 to 7,0	25	50	

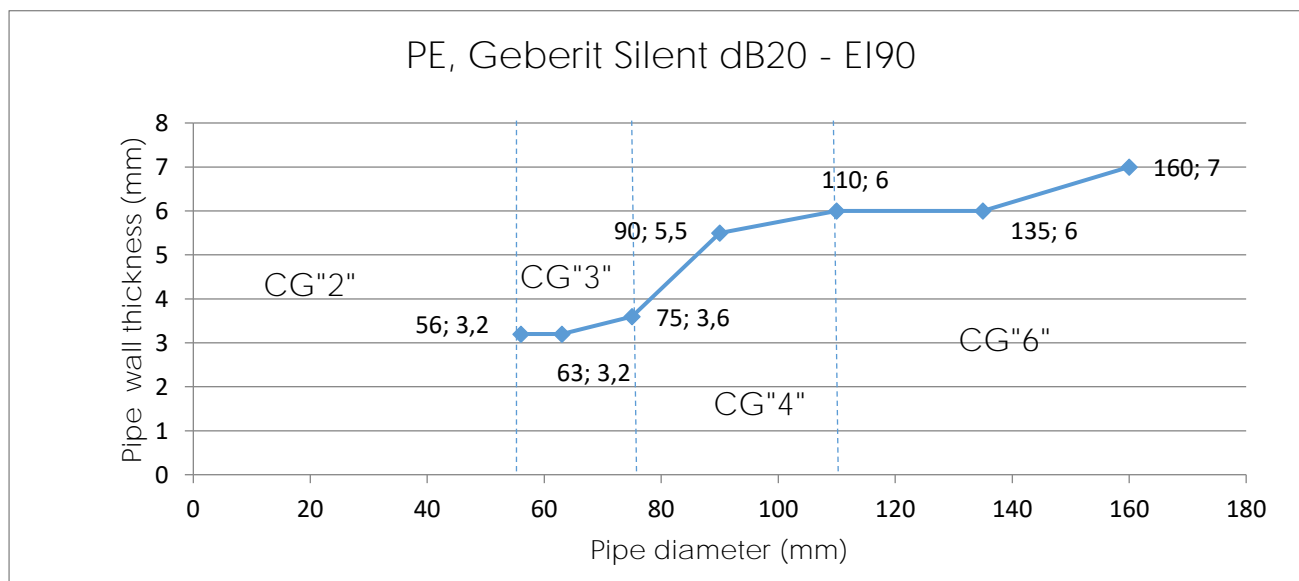

2.6.10.5.5 PE – pipes (Geberit Silent dB20) for EI 120-U/U

PE pipes, designation Geberit Silent dB20, Seal design: i) according to 2.2.14.1					
Layers	Pipe diameter d_c \varnothing (mm)	Pipe wall thickness t_c (mm)	Separation a_2 (mm)	Separation a_3 (mm)	Classification
3	63 to 75	3,2 to 3,6	25	50	EI 120-U/U, E 120-U/U
4	> 75 to 110	3,6 to 6,0	25	50	
6	> 110 to 160	6,0 to 7,0	25	50	

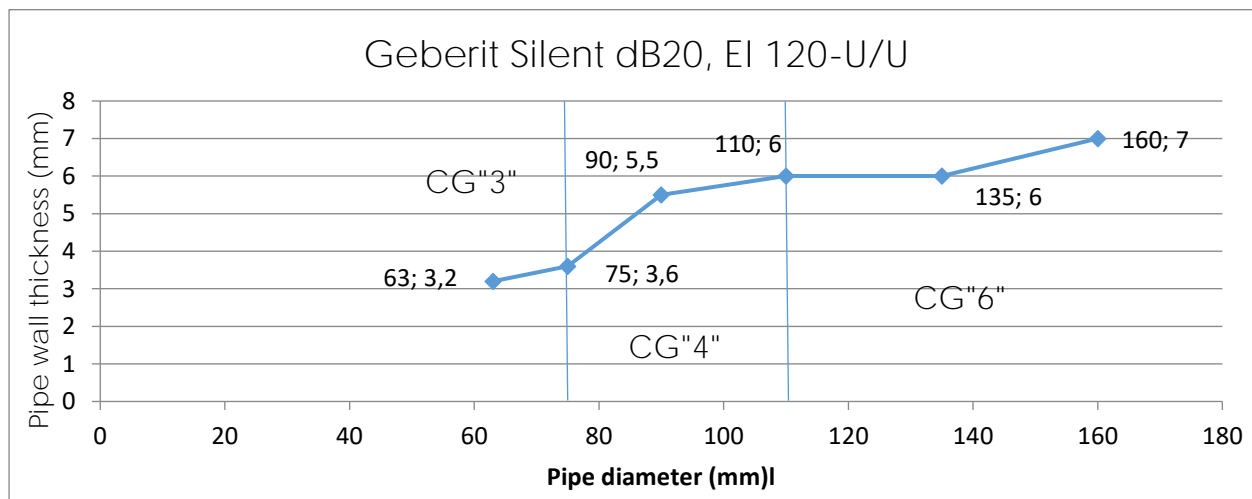

2.6.10.5.6 PE – pipes according EN 15494 for EI 90-U/C

PE pipes acc.EN 15494, Seal design: i) according to 2.2.14.1					
Layers	Pipe diameter d_c \varnothing (mm)	Pipe wall thickness t_c (mm)	Separation a_2 (mm)	Separation a_3 (mm)	Classification
2	32 (1,8/6,9) to 50 (1,8/6,9)		25	25	EI 90-U/C, E 90-U/C
3	> 50 (1,8/6,8) to 63 (1,8/6,8) to 75 (1,9/6,8)		25	25	
4	> 75 (1,9/6,8) to 90 (2,2/7,1) to 125 (3,1/7,1)		25	25	
6	> 125 (3,5/9,1) to 140 (3,5/9,1) to 160 (4,0/9,1)		25	25	

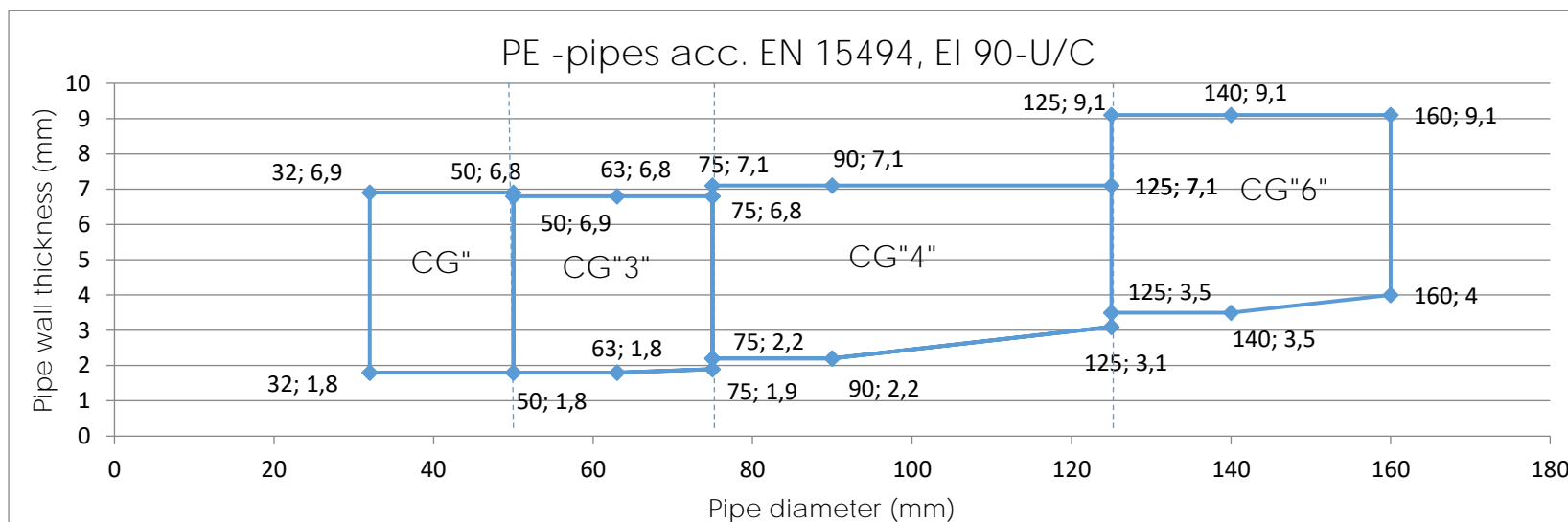

2.6.10.5.7 PE pipes according EN 15494 for EI 120-U/C

PE pipes acc.EN 15494, Seal design: i) according to 2.2.14.1					
Layers	Pipe diameter d_c Ø (mm)	Pipe wall thickness t_c (mm)	Separation a_2 (mm)	Separation a_3 (mm)	Classification
2	32 (1,8/4,6) to Ø50 (1,8/4,6)		50	25	EI 120-U/C, E 120-U/C
3	> 50 (1,8/6,8) to 63 (1,8/6,8) to 75 (1,9/6,8)		50	25	
4	> 75 (2,2/7,1) to 90 (2,2/7,1) to 125 (3,1/7,1)		50	25	
6	> 125 to 140	3,5 to 9,1	50	25	
6	160	9,1	50	25	

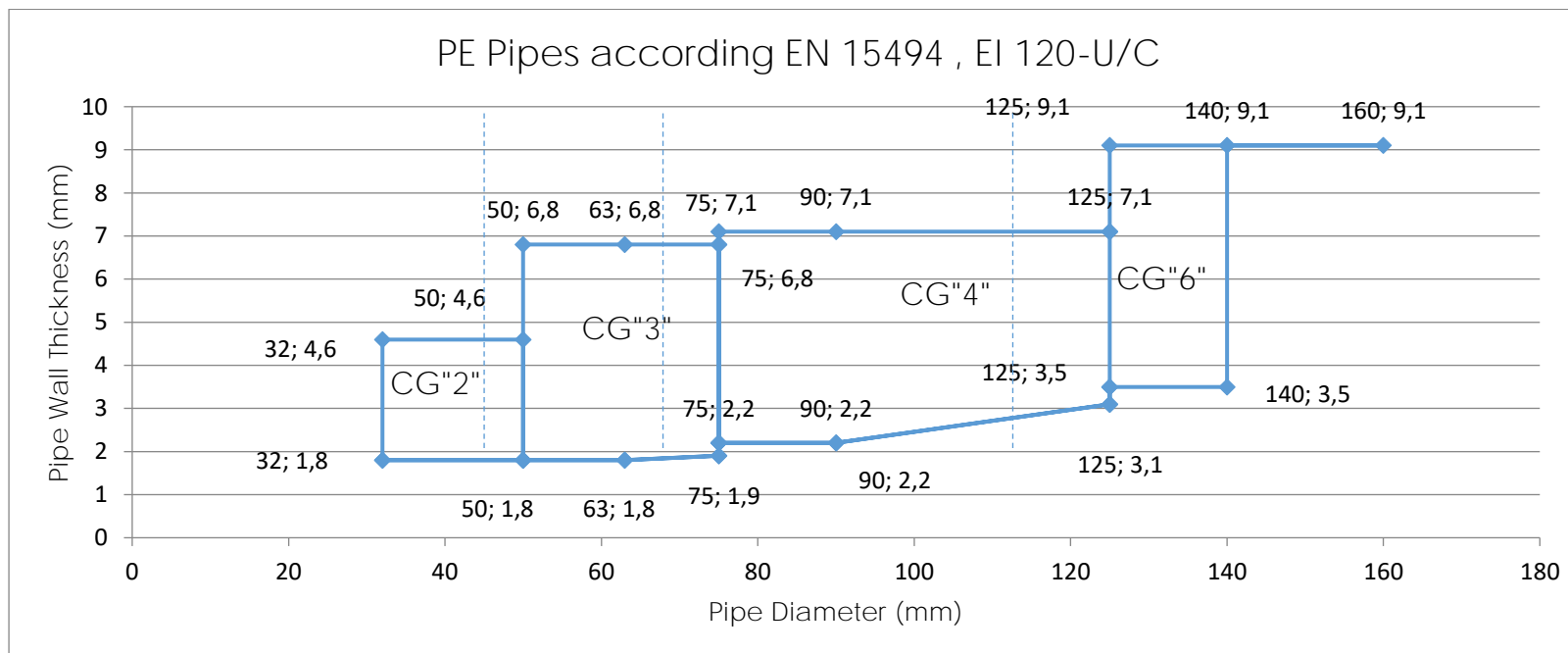

2.6.10.5.8 PP-pipes, non-regulated, for EI 90-U/U

PP acoustic pipes, non-regulated, Seal design: i) according to 2.2.14.1 For pipe designation: refer to 2.1.6					
Layers	Pipe diameter d_c \varnothing (mm)	Pipe wall thickness t_c (mm)	Separation a_2 (mm)	Separation a_3 (mm)	Classification
2	32 (1,8/4,0) to 50 (1,8/4,0) to 58 (4,0/4,0)		25	50	EI 90-U/U, E 120-U/U
3	58 (1,9/3,8) to 75 (1,9/3,8)		25	50	
4	> 75 (2,2/5,3) to 90 (2,2/5,3) to 125 (3,1/5,3)		25	50	
6	> 125 (3,9/7,5) to 160 (3,9/7,5)		25	50	

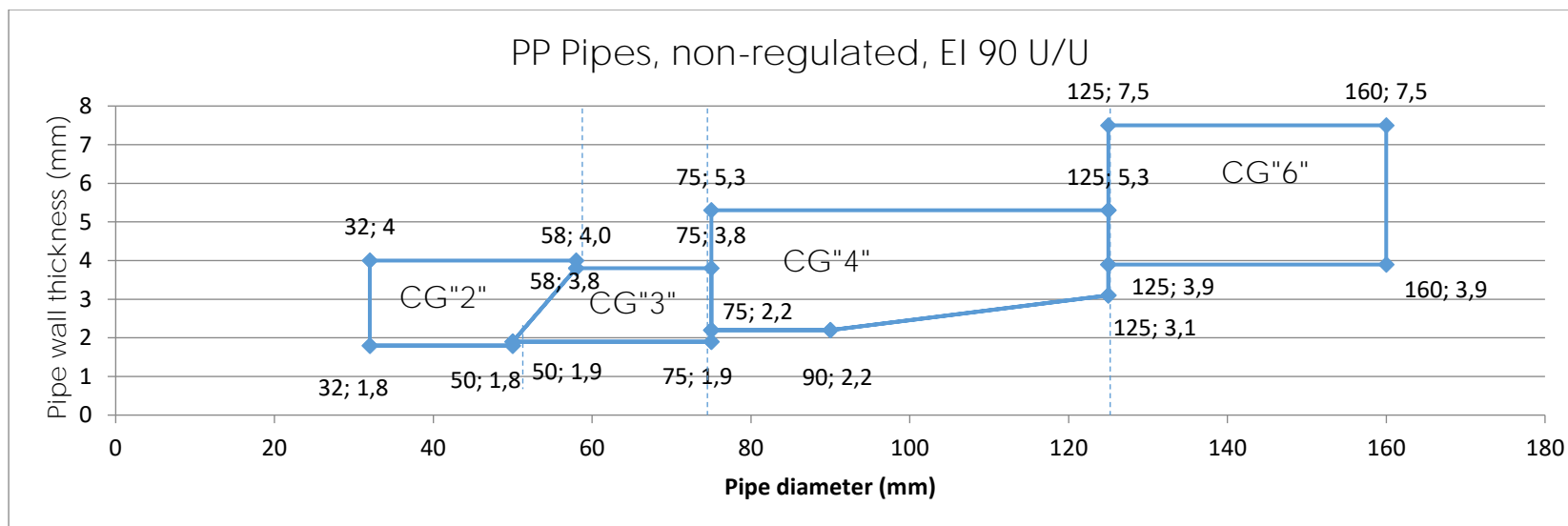

2.6.10.5.9 PP-pipes, non-regulated, for EI 120-U/U

PP acoustic pipes, non-regulated, Seal design: i) according to 2.2.14.1 For pipe designation: refer to 2.1.6					
Layers	Pipe diameter d_c Ø (mm)	Pipe wall thickness t_c (mm)	Separation a_2 (mm)	Separation a_3 (mm)	Classification
2	32 (1,8/4,0) to 50 (1,8/4,0) to 58 (4,0/4,0)		50	100	EI 120-U/U, E 120-U/U
3	58 (1,9/3,8) to 75 (1,9/3,8)		50	100	
4	>75 (2,2/5,3) to 90 (2,2/5,3) to 125 (3,1/5,3)		50	100	
6	> 125 (3,9/7,5) to 160 (3,9/7,5)		50	100	

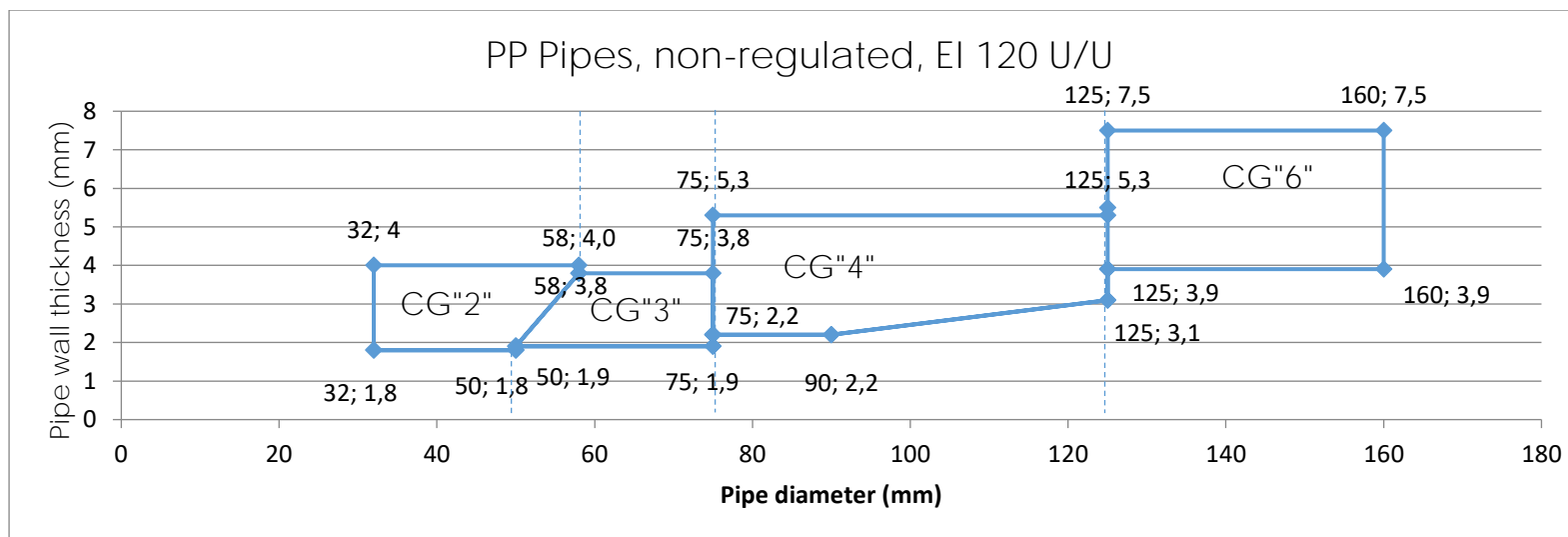

2.6.10.5.10 PVC-pipes according EN 1452-1 for EI 90-U/U

PVC-pipes according to EN 1452-1, Seal design: i) according to 2.6.10.1					
Layers	Pipe diameter d_c \varnothing (mm)	Pipe wall thickness t_c (mm)	Separation a_2 (mm)	Separation a_3 (mm)	Classification
2	32 (1,8/5,6) to 50 (1,8/5,6)		25	50	EI 90-U/U, E 120-U/U
3	> 50 (2,2/5,6) to 75 (2,2/5,6)		25	50	
4	> 75 (2,2/9,3) to 110 (2,2/9,3) to 125 (2,5/9,3)		25	50	
6	> 125 (2,8/6,7) to 140 (2,8/6,7)		25	50	
6	160	3,2	25	50	

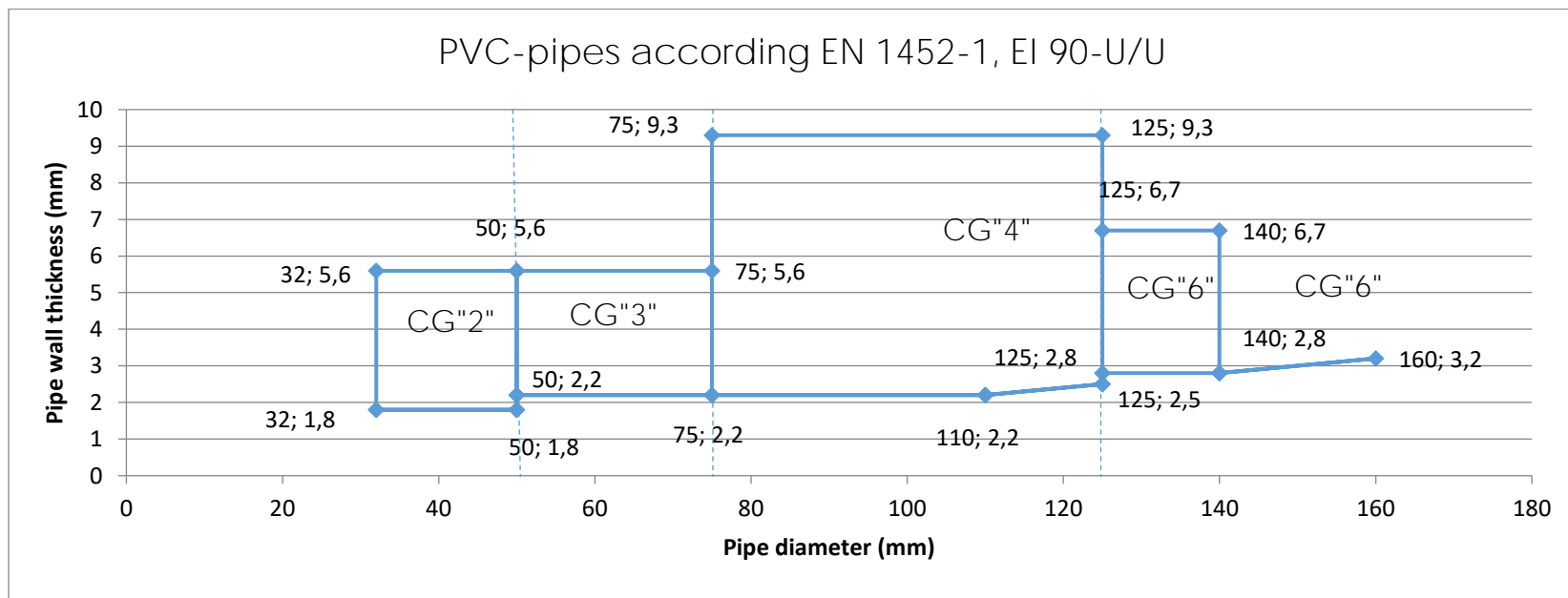

2.6.10.5.11 PVC-pipes according EN 1452-1 for EI 120-U/C

PVC-pipes according to EN 1452-1, Seal design: i) according to 2.6.10.1					
Layers	Pipe diameter d_c \varnothing (mm)	Pipe wall thickness t_c (mm)	Separation a_2 (mm)	Separation a_3 (mm)	Classification
2	32 (1,8/5,6) to 50 (1,8/5,6) to 75 (2,2/5,6)		25	50	EI 120-U/C, E 120-U/U
4	> 75 (2,2/9,3) to 125 (2,5/9,3) to 140 (2,5/7,7) to 160 (2,5/7,7)		25	50	

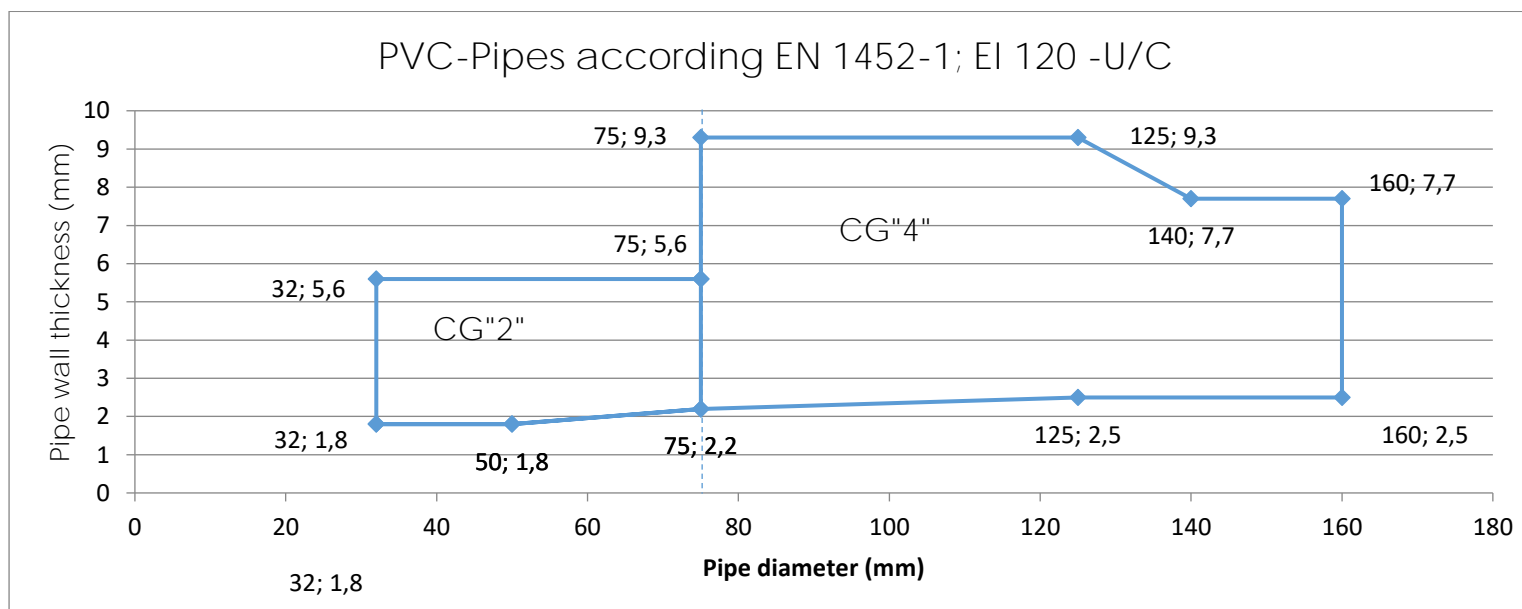

2.6.10.5.12. Geberit PushFit PB

	<p>Material: PB, Seal design: ii) according to 2.6.10.1</p> <p>Approved pipe insulation material (CS): flexible elastomeric insulation see Annex 1 - 1.2.12 table 4, distances: $S_8 \geq 100\text{mm}$, $S_6 \geq 50\text{mm}$ (see 2.2)</p>						
Layers	Pipe diameter \varnothing dc (mm)	Pipe wall thickness t_c (mm)	Pipe insulation Material:	Pipe insulation thickness (mm)	Additional Protect Insulation Material:	Additional Protect Insulation thickness (mm)	Classification
3	20	2,0	Elastomer, see Annex 1 - 1.2.12 table 4	8,5 to 25,0	none	0	EI 120-U/C
3	25	2,5	Elastomer, see Annex 1 - 1.2.12 table 4	9,0 to 27,0	none	0	EI 120-U/C
	Approved pipe insulation material (LS, total length: $\geq 650\text{mm}$): PE hardcover Geberit for Geberit PushFit PB						
1	20	2,0	PE-foam	6	none	0	EI 120-U/C
1	25	2,5	PE-foam	6	none	0	EI 120-U/C

2.6.11 Aluminium composite pipes with elastomeric insulation, penetrating CFS-CT double board seal, provided with Hilti firestop wrap CFS-W P and gap filler in floor

2.6.11.1 Rehau Rautitan Stabil, penetrating CFS-CT, sealed with CFS-W P

Classification : EI 90-U/C, E120-U/C Material: PE-Xa/AL/PE-HD, seal type iii) according 2.6.10.1 , Approved pipe insulation material: see Annex 1 - 1.2.12 table 4						
Layers	Pipe diameter Ø dc (mm)	Pipe wall thickness tc (mm)	Pipe insulation thickness (mm)	Separation a2 (mm)	Separation a3 (mm)	Classification
1	16	2,6	8,0 to 32,0	25	0	EI 90-U/C, E 120
1	20	2,9	8,5 to 33,5	25	0	
1	25	3,7	8,5 to 35,0	25	0	
1	32	4,7	9,0 to 35,0	25	0	
1	40	6,0	9,0 to 35,0	25	0	

Classification : EI 120-U/C, E 120-U/C Material: PE-Xb/AL/PE-HD, seal type iii) according 2.6.10.1 , Approved pipe insulation material: see Annex 1 - 1.2.12 table 4						
Layers	Pipe diameter Ø dc (mm)	Pipe wall thickness tc (mm)	Pipe insulation thickness (mm)	Separation a2 (mm)	Separation a3 (mm)	Classification
1	16	2,6	8,0 to 32,0	50	50	EI 120-U/C, E 120-U/C
1	20	2,9	8,5 to 33,5	50	50	
1	25	3,7	8,5 to 35,0	50	50	
1	32	4,7	9,0 to 35,0	50	50	
1	40	6,0	9,0 to 35,0	50	50	

2.6.11.2 Uponor MLC, penetrating CFS-CT, sealed with CFS-W P

Classification : EI 90-U/C, E 120-U/C Material: PE-RT/AL/PE-RT, seal type iii) according 2.6.10.1 , Approved pipe insulation material: see Annex 1 - 1.2.12 table 4						
Layers	Pipe diameter Ø dc (mm)	Pipe wall thickness tc (mm)	Pipe insulation thickness (mm)	Separation a2 (mm)	Separation a3 (mm)	Classification
1	16	2,0	8,0 to 32,0	25	0	EI 90-U/C, E 120-U/C
1	20	2,25	8,5 to 33,5	25	0	
1	25	2,5	8,5 to 35,0	25	0	
1	32	3,0	9,0 to 35,0	25	0	
2	50	4,5	9,0 to 38,0	25	0	
2	63	6,0	9,5 to 39,5	25	0	
2	75	7,5	9,5 to 40,5	25	0	
Classification : EI 120-U/C, E 120-U/C Material: PE-RT/AL/PE-RT, seal type iii) according 2.6.10.1 , Approved pipe insulation material: see Annex 1 - 1.2.12 table 4						
Layers	Pipe diameter Ø dc (mm)	Pipe wall thickness tc (mm)	Pipe insulation thickness (mm)	Separation a2 (mm)	Separation a3 (mm)	Classification
1	16	2,0	8,0 to 32,0	50	50	EI 120-U/C E 120-U/C
1	20	2,25	8,5 to 33,5	50	50	
1	25	2,5	8,5 to 35,0	50	50	
1	32	3,0	9,0 to 35,0	50	50	
2	50	4,5	9,0 to 38,0	25	0	
2	63	6,0	9,5 to 39,5	25	0	
2	75	7,5	9,5 to 40,5	25	0	

2.6.11.3 Kekelit Kelox, penetrating CFS-CT, sealed with CFS-W P

Classification : EI 90-U/C, E120-U/C Material: PE-X/AL/PE-X, seal type iii) according 2.6.10.1, Approved pipe insulation material: see Annex 1 - 1.2.12 table 4						
Layers	Pipe diameter Ø dc (mm)	Pipe wall thickness tc (mm)	Pipe insulation thickness (mm)	Separation a2 (mm)	Separation a3 (mm)	Classification
1	16	2,0	8,0 to 32,0	25	0	EI 90-U/C, E 120-U/C
1	20	2,25	8,5 to 33,5	25	0	
1	25	2,5	8,5 to 35,0	25	0	
1	32	3,0	9,0 to 35,0	25	0	
2	> 32 to < 75	> 3,0 to < 7,5	9,0 to 35,0	25	0	
2	75	7,5	9,5 to 35,0	25	0	

Classification : EI 120-U/C Material: PE-X/AL/PE-X, seal type iii) according according 2.6.10.1, Approved pipe insulation material: see Annex 1 - 1.2.12 table 4						
Layers	Pipe diameter Ø dc (mm)	Pipe wall thickness tc (mm)	Pipe insulation thickness (mm)	Separation a2 (mm)	Separation a3 (mm)	Classification
1	16	2,0	8,0 to 32,0	25	50	EI 120-U/C, E 120-U/C
1	20	2,25	8,5 to 33,5	25	50	
1	25	2,5	8,5 to 35,0	25	50	
1	32	3,0	9,0 to 35,0	25	50	
2	> 32	> 3,0	9,0 to 35,0	25	50	

2	75	7,5	9,5 to 35,0	25	50	
---	----	-----	-------------	----	----	--

2.6.11.4 Geberit Mepla, penetrating CFS-CT, sealed with CFS-W P

Classification : EI 90-U/C, E120-U/C Material: PE-Xb/AL/PE-HD, seal type iii) according 2.6.10.1 Approved pipe insulation material: see Annex 1 - 1.2.12 table 4						
Layers	Pipe diameter Ø dc (mm)	Pipe wall thickness tc (mm)	Pipe insulation thickness (mm)	Separation a2 (mm)	Separation a3 (mm)	Classification
1	16	2,3	8,0 to 32,0	25	0	EI 90-U/C, E 120-U/C
1	20	2,5	8,5 to 33,5	25	0	
1	26	3,0	8,5 to 35,0	25	0	
1	32	3,0	9,0 to 35,0	25	0	
2	40	3,5	9,0 to 36,5	25	0	
2	50	4,0	9,0 to 38,0	25	0	
2	63	4,5	9,5 to 39,5	25	0	
2	75	4,7	9,5 to 40,5	25	0	

2.6.11.5 Viega Sanfix Fosta and Viega Raxofix, penetrating CFS-CT, sealed with CFS-W P

<p>Material: PE-Xc/AL/PE-Xc, seal type iii) according 2.6.10.1</p> <p>Approved pipe insulation material (CS): flexible elastomeric insulation see Annex 1 - 1.2.12 table 4, distances: $S_8 \geq 100\text{mm}$, $S_6 \geq 50\text{mm}$ (see 2.6)</p> <p>Additional Protect Insulation (LI, 250mm): flexible elastomeric insulation see Annex 1 - 1.2.12 table 4 or mineral wool see AP7</p>							
Layers	Pipe diameter \varnothing dc (mm)	Pipe wall thickness t_c (mm)	Pipe insulation Material:	Pipe insulation thickness (mm)	Additional Protect Insulation Material:	Additional Protect Insulation thickness (mm)	Classification
1	16	2,2	Elastomer, see Annex 1 - 1.2.12 table 4	8,0 to 32,0	none	0	EI 120-U/C
1	20	2,8	Elastomer, see Annex 1 - 1.2.12 table 4	8,5 to 33,5	none	0	EI 120-U/C
1	25	2,7	Elastomer, see Annex 1 - 1.2.12 table 4	8,5 to 35,0	none	0	EI 120-U/C
1	32	3,2	Elastomer, see Annex 1 - 1.2.12 table 4	9,0 to 35,0	none	0	EI 120-U/C
1	40	3,5	Elastomer, see Annex 1 - 1.2.12 table 4	9,0 to 36,5	none	0	EI 120-U/C
2	50	4,0	Elastomer, see Annex 1 - 1.2.12 table 4	9,0 to 38,0	none	0	EI 60-U/C
2	63	4,5	Elastomer, see Annex 1 - 1.2.12 table 4	9,5 to 39,5	none	0	EI 60-U/C
2	63	4,5	Elastomer, see Annex 1 - 1.2.12 table 4	9,5 to 39,5	Elastomer, see Annex 1 - 1.2.12 table 4	19	EI 120-U/C
2	63	4,5	Elastomer, see Annex 1 - 1.2.12 table 4	9,5 to 39,5	Mineral wool	30	EI 120-U/C

Viega Sanfix Fosta and Raxofix pipes: Material: PE-Xc/AL/PE-Xc, Approved pipe insulation material (CS): Mineral wool insulation see Annex 1 - 1.2.12 table 3, distances: $S_8 \geq 100\text{mm}$, $S_6 \geq 50\text{mm}$ (see 2.6)							
Layers	Pipe diameter \varnothing dc (mm)	Pipe wall thickness t_c (mm)	Pipe insulation Material:	Pipe insulation thickness (mm)	Additional Protect Insulation Material:	Additional Protect Insulation thickness (mm)	Classification
0	16	2,2	Mineral wool	20 to 40	none	0	EI 120-U/C
0	20	2,8	Mineral wool	20 to 50	none	0	EI 120-U/C
0	25	2,7	Mineral wool	20 to 60	none	0	EI 120-U/C
0	32	3,2	Mineral wool	20 to 60	none	0	EI 120-U/C
0	40	3,5	Mineral wool	20 to 60	none	0	EI 120-U/C
0	50	4,0	Mineral wool	20 to 60	none	0	EI 120-U/C
0	63	4,5	Mineral wool	20 to 60	none	0	EI 120-U/C

2.6.11.6 Geberit PushFit ML, penetrating CFS-CT, sealed with CFS-W P

Material: PE-HD/AL/PE-HD, seal type iii) according 2.6.10.1 respectively no seal type for mineral woll insulation Approved pipe insulation material (CS): flexible elastomeric insulation see Annex 1 - 1.2.12 table 4, distances: $S_8 \geq 100\text{mm}$, $S_6 \geq 50\text{mm}$ (see 2.2)							
Layers	Pipe diameter \varnothing dc (mm)	Pipe wall thickness t_c (mm)	Pipe insulation Material:	Pipe insulation thickness (mm)	Additional Protect Insulation Material:	Additional Protect Insulation thickness (mm)	Classification
1	20	2,0	Elastomer	8,5 to 33,5	none	0	EI 120-U/C
1	25	2,5	Elastomer	8,5 to 35,0	none	0	EI 120-U/C
0	20	2,0	Mineral wool	20 to 40	none	0	EI 120-U/C
0	25	2,5	Mineral wool	20 to 60	none	0	EI 120-U/C
Approved pipe insulation material (LS, total length: $\geq 650\text{mm}$): flexible PE isolation							
1	20	2,0	PE-foam	6	none	0	EI 120-U/C
1	25	2,5	PE-foam	6	none	0	EI 120-U/C

2.6.12 Metal pipes with elastomeric insulation, penetrating a CFS-CT double board seal, provided with Hilti firestop wrap CFS-W P and gap filler

2.6.12.1 Isolated copper pipes, penetrating CFS-CT, sealed with CFS-W P

Classification : EI 90-C/U Material: copper, seal type iv) according 2.6.10.1 Approved pipe insulation material: see Annex 1 - 1.2.12 table 4						
Layers	Pipe diameter Ø dc (mm)	Pipe wall thickness tc (mm)	Pipe insulation thickness (mm)	Separation a2 (mm)	Separation a3 (mm)	Classification
1	10	1,0	7,5 to 32,0	25	50	EI 90-C/U, E 120-C/U
2	> 10 to 42	1,0 to 1,2	7,5/9,0 to 32,0/36,5	25	50	

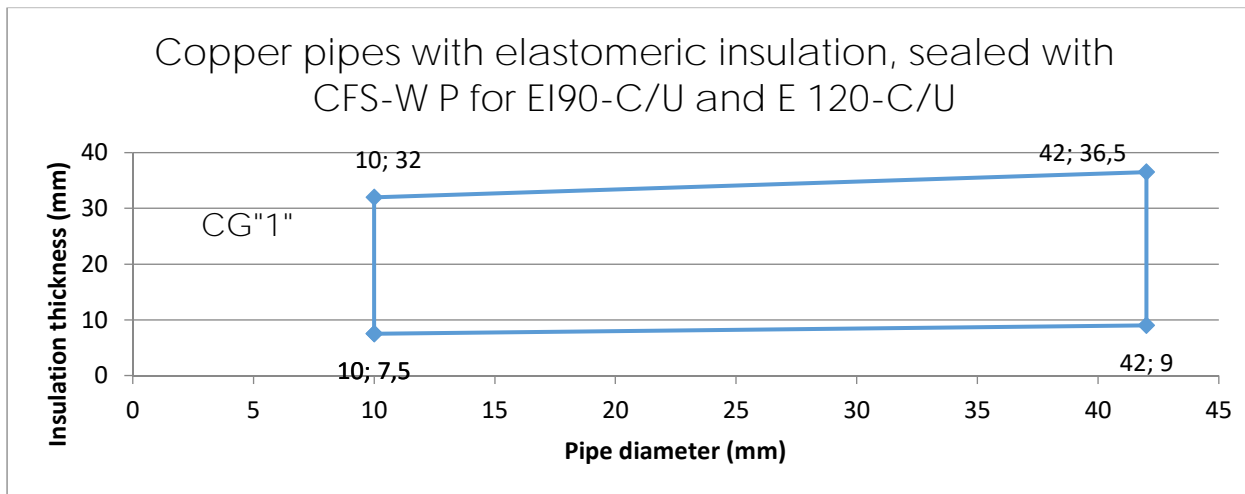

2.6.12.2 Isolated steel pipes, penetrating CFS-CT, sealed with CFS-W P

Classification : EI 90-C/U Material: steel, seal type v) according 2.6.10.1 Approved pipe insulation material: see Annex 1 - 1.2.12 table 4						
Layers	Pipe diameter Ø dc (mm)	Pipe wall thickness tc (mm)	Pipe insulation thickness (mm)	Separation a2 (mm)	Separation a3 (mm)	Classification
1	10	1,0	7,5 to 32,0	25	50	EI 90-C/U, E 120-C/U
2	> 10 to 42 to 114	1,0 1,2 3,4	7,5/32,0 to 9,0/36,0 to 15,0/43,0	25	50	
3	> 114 to 219	3,4 to 6,3	15,0/19,0 to 43,0/50,0	25	50	

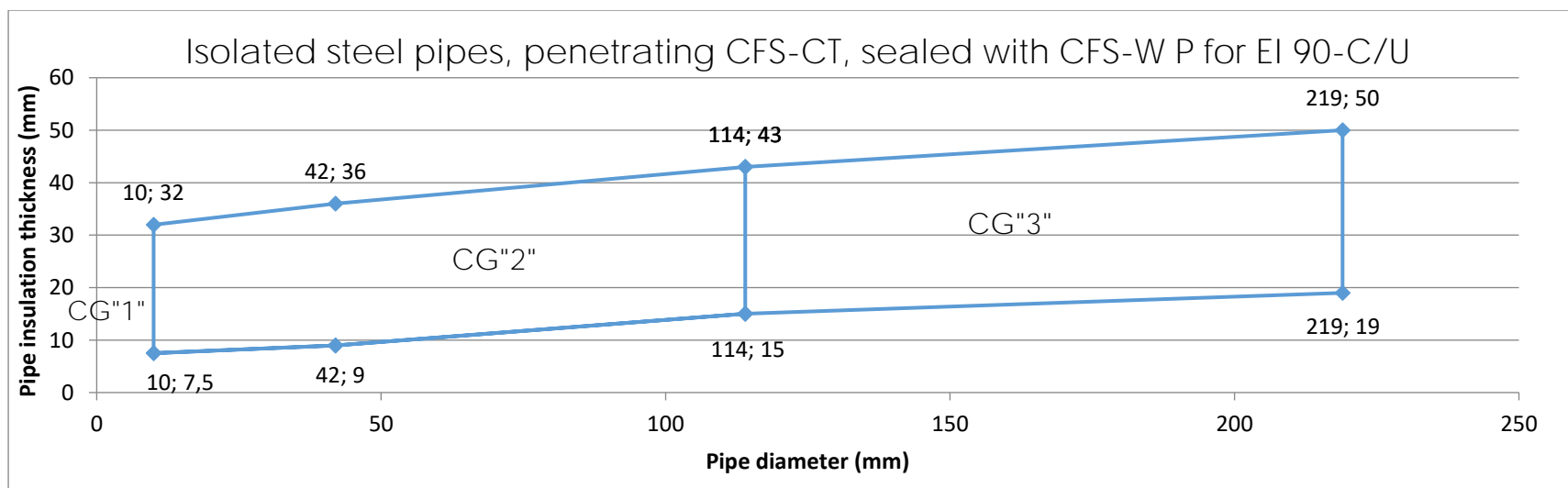

Material: stainless steel, steel, iron; seal type v) according 2.6.10.1

Approved flexible, elastomeric pipe insulation (CS) and additional pipe insulation (LI, 250mm) (AP8 – refer to Annex 2 - 2.1.4): for material see Annex 1 - 1.2.12 table 3 and table 4

Pipe designation: Geberit Mapress , distances: $S_8 \geq 100\text{mm}$, $S_6 \geq 50\text{mm}$ (see 2.6)

Layers	Pipe diameter \varnothing dc (mm)	Pipe wall thickness tc (mm)	Pipe Insulation Type	Pipe insulation thickness (mm)	Additional Pipe Insulation Type	Additional Pipe Insulation Thickness (mm)	Classification
2	66,7	1,5	Elastomer	17,5 to 40,0	none	0	EI 90-C/U
2	66,7	1,5	Elastomer	9,5 to 40,0	Elastomer see Annex 1 - 1.2.12 table 4	19	EI 120-C/U
2	66,7	1,5	Elastomer	9,5 to 40,0	Mineral wool, see Annex 1 - 1.2.12 table 3	30	EI 120-C/U
2	108	2,0	Elastomer	18,0 – 42,5	none	0	EI 30-C/U
2	108	2,0	Elastomer	18,0 – 42,5	Elastomer see Annex 1 - 1.2.12 table 4	19	EI 60-C/U
2	108	2,0	Elastomer	18,0 – 42,5	Mineral wool, see Annex 1 - 1.2.12 table 3	30	EI 120-C/U

2.6.13 AI-Composite pipes with foamed elastomeric insulation according to Table 4 and Hilti Firestop Collar CFS-C P

Construction details

(for symbols and abbreviations see Annex 4):

For specification of the foamed elastomeric insulation material to be used see table 4.

Hilti Firestop Collar CFS-C P (A₃) is installed on bottom side of the seal, fixed by threaded rods, washers and nuts as specified in Annex 1.2.

In some cases an additional protection is required:

AP₉: Mineral wool board according to Table installed around the pipe in the air gap between the two boards of the Hilti Firestop Double Board Seal.

Width around the pipe 100 mm, thickness 50 mm (height of the air gap).

Local insulation, sustained (LS)

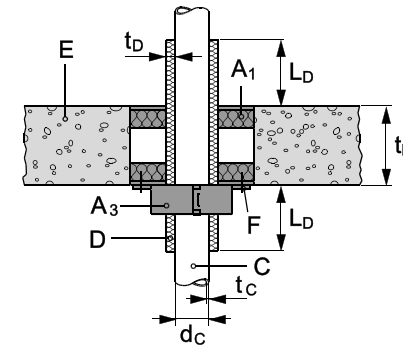

2.6.13.1 Pipes (C) with local insulation (D) – sustained – U/C

PE-Xb/AI/PE-HD "Geberit Mepla", Manufacturer: Geberit

Pipe		Insulation		Collar size (A ₃)	No. of hooks	Classification
diameter (d _c) [mm]	wall thickness (t _c) [mm]	thickness (t _D) [mm]	length (L _D) [mm]			
40	3.5	9	≥ 250	CFS-C P 63/2"	2	EI 90-U/C
63	4.5	9	≥ 250	CFS-C P 75/2.5"	3	EI 90-U/C
75	4.7	9	≥ 250	CFS-C P 90/3"	3	EI 90-U/C

PE-X/AI/PE "KELOX KM 110"

Manufacturer: KeKelit Kunststoffwerk

Pipe		Insulation		Collar size (A ₃)	No. of hooks	Classification
diameter (d _c) [mm]	wall thickness (t _c) [mm]	thickness (t _D) [mm]	length (L _D) [mm]			
40	4	9	≥ 250	CFS-C P 50/1.5"	2	EI 90-U/C
63	6	9	≥ 250	CFS-C P 75/2.5"	3	EI 90-U/C

2.6.13.2 Pipes (C) with continued insulation (D) – sustained – U/C

PE-Xb/AI/PE-HD “Geberit Mepla”

Manufacturer: Geberit

Pipe		Insulation	Collar size (A ₃)	No. of hooks	Classification
diameter (d _c) [mm]	wall thickness (t _c) [mm]	thickness (t _D) [mm]			
Additional protection					AP ₉
16	2.3	8.0 (AF1)	CFS-C P 50/1.5”	2	EI 120-U/C
16	2.3	32.0 (AF6)	CFS-C P 90/3”	3	EI 120-U/C
32	3.0	9.0 (AF1)	CFS-C P 50/1.5”	2	EI 120-U/C
32	3.0	35.0 (AF6)	CFS-C P 110/4”	4	EI 120-U/C

PE-X/AI/PE “KELOX KM 110”

Manufacturer: KeKelit Kunststoffwerk

Pipe		Insulation	Collar size (A ₃)	No. of hooks	Classification
diameter (d _c) [mm]	wall thickness (t _c) [mm]	thickness (t _D) [mm]			
Additional protection					AP ₉
16	2.0	8.0 (AF1)	CFS-C P 50/1.5”	2	EI 120-U/C
16	2.0	32.0 (AF6)	CFS-C P 90/3”	3	EI 120-U/C
32	3.0	9.0 (AF1)	CFS-C P 50/1.5”	2	EI 120-U/C
32	3.0	35.0 (AF6)	CFS-C P 110/4”	4	EI 120-U/C

2.6.14 Al-composite pipes and plastic pipes with mineral wool insulation according to Table 3

Construction details (for symbols and abbreviations see Annex 4):

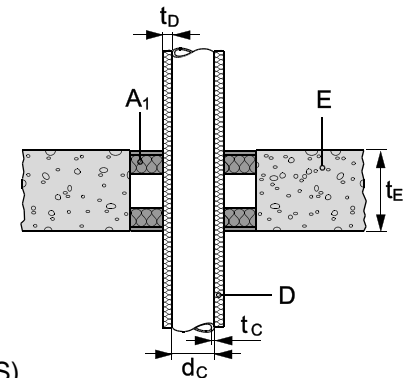

Continued insulation, sustained (CS)

2.6.14.1 Aluminum composite pipes (C) with continued insulation (D) – sustained – U/C

PE-Xb/Al/PE-HD pipes „Geberit Mepla“

Manufacturer: Geberit

Pipe diameter (d _c) [mm]	Pipe wall thickness (t _c) [mm]	Insulation thickness (t _b) [mm]	Classification
16	2.3	≥ 20	EI 180-U/C
32	3.0	≥ 20	EI 180-U/C
75	4.7	≥ 20	EI 180-U/C

VPE/Al/VPE pipes „Kelox KM 110“

Manufacturer: KeKelit

Pipe diameter (d _c) [mm]	Pipe wall thickness (t _c) [mm]	Insulation thickness (t _b) [mm]	Classification
16	2.0	≥ 20	EI 180-U/C
32	3.0	≥ 20	EI 180-U/C
75	7.5	≥ 20	EI 180-U/C

2.6.10.2 PE pipes (C) with continued insulation (D) – sustained – U/C**PE-Xa pipes “Rautitan flex “**

Manufacturer: Rehau

Pipe diameter (d _c) [mm]	Pipe wall thickness (t _c) [mm]	Insulation thickness (t _D) [mm]	Classification
16	2.2	≥ 20	EI 180-U/C
32	4.4	≥ 20	EI 180-U/C
63	8.6	≥ 20	EI 180-U/C

2.7 Rigid walls according to 2.1 f) minimum thickness 250 mm

Penetration seal:

Two 50 mm Hilti Firestop Boards CFS-CT B 1S¹² (A₁) or mineral wool boards according to Table 1 coated with Hilti Firestop Coating CFS-CT (A₁), dry thickness of coating 0.7 mm on the outer side¹³, all cut edges of boards sealed with Hilti Firestop Acrylic Sealant CFS-S ACR, remaining gaps around cables / cable supports (trays, ladders etc.) and other services filled with Hilti Firestop Acrylic Sealant CFS-S ACR.

The boards have to be positioned flush to the surface of the building element on each side of the wall.

Maximum distance for 1st service support: 250 mm.

Maximum seal size: 1200 x 1200 mm (width x height) for classification EI 120, 1200 x 2000 mm (width x height) for classification EI 90.

Minimum distances in mm (see illustration below):

s ₁ = 0	(distance between cables/cable supports and seal edge)
s ₂ = 0	(distance between cable supports)
s ₃ = 0	(distance between cables and upper seal edge)
s ₄ = 0	(distance between cable supports and bottom seal edge)
s ₅ = 50	(distance between cables and cable support above)
s ₆ = 3	(distance between metal pipes and seal edge)
s ₇ = 3	(distance between metal pipes and upper seal edge)
s ₈ = 0	(distance between metal pipes)
s ₉ = 17	(distance between plastic pipes/pipe closure devices and seal edge)
s ₁₀ = 17	(distance between plastic pipes/pipe closure devices and upper seal edge)
s ₁₁ = 0	(distance between plastic pipes/pipe closure devices)
s ₁₂ = 30	(distance between metal pipes and plastic pipes/pipe closure devices)
s ₁₃ = 3	(distance between cables/cable supports and metal pipes)
s ₁₄ = 40	(distance between cables/cable supports and plastic pipes/pipe closure devices)

12 Hilti Firestop Boards CFS-CT B 2S (coated on both faces) may also be used

13 The board may also be coated on both faces

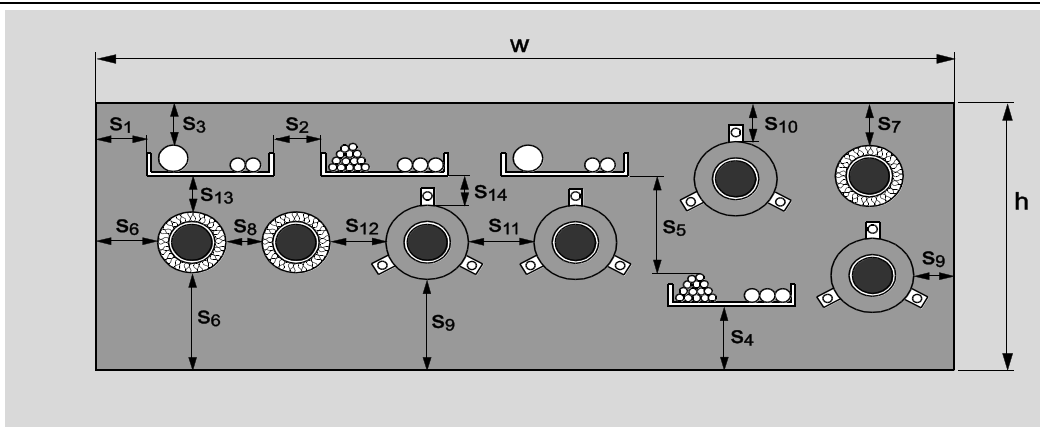

Penetrating services :(single, multiple or mixed)

2.7.1 Blank seal (no services) *

Construction details (for symbols and abbreviations see Annex 4):

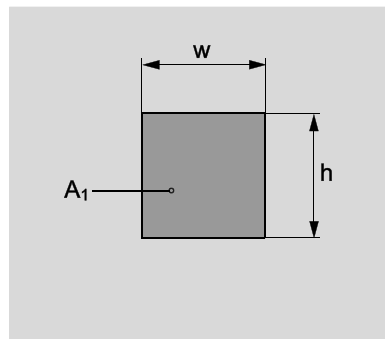

* If services are added later on in a blank seal only the services listed in the tables below may be added that fulfil the required classification

Maximum size 1200 x 2000 mm² (width **w** x height **h**)

Maximum size 4000mm x 800 mm (width **w** x height **h**) rigid wall only, $t_E \geq 250\text{mm}$, density $\geq 500\text{kg/m}^3$

Classification

EI 90

EI 90 / E90

3 ANNEX 3 Reference Documents

3.1 References to standards mentioned in the ETA:

DIN 8061	Unplasticized polyvinyl chloride (PVC-U) pipes - General quality requirements and testing
DIN 8062	Unplasticized polyvinyl chloride (PVC-U) pipes - Dimensions
DIN 8074	Polyethylene (PE) - Pipes PE 63, PE 80, PE 100, PE-HD - Dimensions
DIN 8075	Polyethylene (PE) pipes - PE 63, PE 80, PE 100, PE-HD - General quality requirements, testing
DIN 8077	Polypropylene (PP) pipes - PP-H, PP-B, PP-R, PP-RCT - Dimensions
DIN 8078	Polypropylene (PP) pipes - PP-H, PP-B, PP-R, PP-RCT - General quality requirements and testing
DIN 19531-10	Pipes and fittings made of unplasticized polyvinyl chloride (PVC-U) socket for waste and soil discharge systems inside buildings - Part 10: Fire behavior, quality control and installation recommendations
DIN 19535-10	High-density polyethylene (PE-HD) pipes and fittings for hot-water resistant waste and soil discharge systems (HT) inside buildings - Part 10: Fire behavior, quality control and installation recommendations
EN 1026	Windows and doors – Air permeability – Test method
EN 1329-1	Plastics piping systems for soil and waste discharge (low and high temperature) within the building structure - Unplasticized poly(vinyl chloride) (PVC-U) - Part 1: Specifications for pipes, fittings and the system
EN 1366-3	Fire resistance tests for service installations - Part 3: Penetration seals
EN 1453-1	Plastics piping systems with structured-wall pipes for soil and waste discharge (low and high temperature) inside buildings - Unplasticized poly(vinyl chloride) (PVC-U) - Part 1: Specifications for pipes and the system
EN 1519	Plastics piping systems for soil and waste discharge (low and high temperature) within the building structure - Polyethylene (PE)
EN 1566-1	Plastics piping systems for soil and waste discharge (low and high temperature) within the building structure - Chlorinated poly(vinyl chloride) (PVC-C) - Part 1: Specifications for pipes, fittings and the system
EN 12201-2	Plastics piping systems for water supply, and for drainage and sewerage under pressure - Polyethylene (PE) - Part 2: Pipes
EN 12666-1	Plastics piping systems for non-pressure underground drainage and sewerage - Polyethylene (PE) - Part 1: Specifications for pipes, fittings and the system
EN 12667	Thermal performance of building materials and products – Determination of thermal resistance by means of guarded hot plate and heat flow meter methods – Products of high and medium thermal resistance

EN 13501-1	Fire classification of construction products and building elements – Part 1: Classification using test data from reaction to fire tests
EN 13501-2	Fire classification of construction products and building elements – Part 2: Classification using test data from fire resistance tests
EN 14303	Thermal insulation products for building equipment and industrial installations - Factory made mineral wool (MW) products – Specification
EN 14304	Thermal insulation products for building equipment and industrial installations - Factory made flexible elastomeric foam (FEF) products - Specification
EN ISO 140-3	Acoustics – Measurement of sound insulation in buildings and of building elements – Part 3: Laboratory measurements of airborne sound insulation of building elements
EN ISO 140-10	Acoustics – Measurements of sound insulation in buildings and of building elements – Part 10: Laboratory measurement of airborne sound insulation of small building elements
EN ISO 717-1	Acoustics – Rating of sound insulation of buildings and of building elements – Part 1: Airborne sound insulation
EN ISO 1452-2	Plastics piping systems for water supply and for buried and above-ground drainage and sewerage under pressure - Unplasticized poly (vinyl chloride) (PVC-U) - Part 2: Pipes
EN ISO 1519	Paints and varnishes – Bend test (cylindrical mandrel)
EN ISO 4032	Hexagon nuts, style 1 - Product grades A and B
EN ISO 7089	Plain washers - Normal series - Product grade A
EN ISO 15493	Plastics piping systems for industrial applications - Acrylonitrile-butadiene-styrene (ABS), unplasticized poly(vinyl chloride) (PVC-U) and chlorinated poly(vinyl chloride) (PVC-C) - Specifications for components and the system; Metric series
EN ISO 15494	Plastics piping systems for industrial applications - Polybuten (PB), polyethylene (PE) and polypropylene (PP) - Specifications for components and the system; Metric series
EN ISO 15874	Plastics piping systems for hot and cold water installations - Polypropylene (PP)
EN ISO 15875	Plastics piping systems for hot and cold water installations - Cross-linked polyethylene (PE-X)

3.2 Other referenced documents

EOTA TR 001	Determination of impact resistance of panels and panel assemblies
EOTA TR 024	Characterization, Aspects of Durability and Factory Production Control for Reactive Materials, Components and Products

4 ANNEX 4 Abbreviations used in drawings

Abbreviation	Description
A ₁	Mineral wool board coated with Hilti Firestop Coating CFS-CT or Hilti Firestop Coated Board CFS-CT B 1S / CFS-CT B 2S
A ₂	Hilti Firestop Bandage CFS-B
A ₃	Hilti Firestop Collar CFS-C, CFS-C P or CFS-C EL
A ₄	Hilti Firestop Wrap CFS-W or CFS-W P
A ₅	Hilti Firestop Sleeve CFS-SL M
A ₆	Hilti Firestop Acrylic Sealant CFS-S ACR as gap filler
AP ₁ to AP ₁₂	Additional protection for services
C, C ₁ , C ₂ , C ₃	Penetrating services
D	Pipe insulation
d _c	Pipe diameter
E, E ₁ , E ₂	Building element (wall, floor)
F	Fixing of pipe closure device
G	Additional supporting construction for blank seal with floor application
h	Height of the penetration seal
l	Length of the penetration seal
L _{AP}	Length of the additional protection
L _D	Length of the pipe insulation
s ₁ , s ₂ , a ₁ , a ₂ , a ₃	Distances
t _{AP}	Thickness of additional protection
t _c	Pipe wall thickness
t _D	Thickness of pipe insulation
t _E	Thickness of the building element
w	Width of the penetration seal