



Austrian Institute of Construction Engineering
 Schenkenstrasse 4 | T+43 1 533 65 50
 1010 Vienna | Austria | F+43 1 533 64 23
 www.oib.or.at | mail@oib.or.at



European Technical Assessment

ETA-10/0389
of 04.09.2017

General part

Technical Assessment Body issuing the European Technical Assessment

Österreichisches Institut für Bautechnik (OIB)
Austrian Institute of Construction Engineering

Trade name of the construction product

Hilti Firestop Acrylic Sealant CFS-S ACR

Product family to which the construction product belongs

Fire Stopping and Fire Sealing Products:
Linear Joint and Gap Seals

Manufacturer

Hilti AG
Feldkircherstrasse 100
9494 Schaan
LIECHTENSTEIN

Manufacturing plant

Hilti production plant 4a

This European Technical Assessment contains

27 pages including Annexes 1 to 3 which form an integral part of this assessment.

This European Technical Assessment is issued in accordance with Regulation (EU) No 305/2011, on the basis of

Guideline for European technical approval for "Fire Stopping and Fire Sealing Products", ETAG 026 Part 3: "Linear Joint and Gap Seals", edition August 2011, used as European Assessment Document (EAD)

This European Technical Assessment replaces

European Technical Assessment ETA-10/0389 of 13.02.2017

This European Technical Assessment is not to be transferred to manufacturers or agents of manufacturer other than those indicated on page 1, or manufacturing plants other than those laid down in the context of this European Technical Assessment.

Translations of this European Technical Assessment in other languages shall fully correspond to the original issued document and should be identified as such.

Communication of this European Technical Assessment, including transmission by electronic means, shall be in full. However, partial reproduction can be made with the written consent of the Österreichisches Institut für Bautechnik. In this case, partial reproduction has to be designated as such.

This European Technical Assessment may be withdrawn by the Österreichisches Institut für Bautechnik, in particular pursuant to information by the Commission according to Article 25 (3) of Regulation (EU) No 305/2011.

electronic copy
electronic copy
electronic copy
electronic copy
electronic copy
electronic copy
electronic copy

Specific parts

1 Technical description of the product

“Hilti Firestop Acrylic Sealant CFS-S ACR” is a sealant used to form a linear joint or gap seal with mineral wool, “Hilti Firestop Round Cord CFS-CO” or combustible material as backfilling material. For details of the seal design depending on orientation, building elements forming the joint/gap or backfilling material and the related classifications see Annex 3 of the ETA.

For further details on “Hilti Firestop Acrylic Sealant CFS-S ACR”, “Hilti Firestop Round Cord CFS-CO” and for a specification of suitable backfilling material see Annex 3 of the ETA.

2 Specification of the intended use(s) in accordance with the applicable European Assessment Document (hereinafter EAD)

2.1 Intended use

The intended use of “Hilti Firestop Acrylic Sealant CFS-S ACR” is to reinstate the fire resistance performance of flexible wall constructions, rigid wall constructions, rigid floor constructions and horizontal and vertical steel constructions at linear gaps/joints within those constructions or where they are abutting another wall or floor construction.

The specific elements of construction between which “Hilti Firestop Acrylic Sealant CFS-S ACR” may be used to provide a linear joint seal, are:

- Flexible walls
- Rigid walls
- Rigid floors
- Steel constructions

For detail specifications of construction elements see Annex 3 of the ETA.

The supporting construction must be classified in accordance with EN 13501-2 for the required fire resistance period.

2.2 Use category

“Hilti Firestop Acrylic Sealant CFS-S ACR” has been tested in accordance with EOTA TR 024, table 4.2 for the Y₂ use category specified in ETAG 026-3 and the results of the test have demonstrated suitability for linear joint and gap seals intended for use at temperatures below 0°C, but with no exposure to rain or UV.

2.3 Working life

The provisions made in this European Technical Assessment are based on an assumed working life of “Hilti Firestop Acrylic Sealant CFS-S ACR” of 10 years, provided the conditions laid down in the technical literature of the manufacturer relating to packaging, transport, storage, installation, use and repair are met.

The indications given on the intended working life cannot be interpreted as a guarantee given by the producer or the Technical Assessment Body, but are to be regarded only as a means for selecting the appropriate product in relation to the expected economically reasonable working life of the works.

The real working life might be, in normal use conditions, considerably longer without major degradation affecting the Basic requirements for construction works.

2.4 General assumptions

It is assumed that damages to the seal are repaired accordingly.

2.5 Manufacturing

The European Technical Assessment is issued for the product on the basis of agreed data / information, deposited with the Österreichisches Institut für Bautechnik, which identifies the product that has been assessed and judged. Changes to the product or production process, which could result in this deposited data / information being incorrect, should be notified to the Österreichisches Institut für Bautechnik before the changes are introduced.

The Österreichisches Institut für Bautechnik will decide whether or not such changes affect the European Technical Assessment and consequently the validity of the CE marking on the basis of the European Technical Assessment and if so whether further assessment or alterations to the European Technical Assessment, shall be necessary.

2.6 Installation

The product shall be installed and used as described in this European Technical Assessment. Additional marking of the linear joint or gap seal shall be done in case of national requirements.

electronic copy electronic copy electronic copy electronic copy electronic copy electronic copy electronic copy electronic copy electronic copy electronic copy

3 Performance of the product and references to the methods used for its assessment

Basic requirements for construction works	Essential characteristic	Method of verification	Performance
BWR 2	Reaction to fire	EN 13501-1:2007	Clause 3.1.1 of the ETA
	Resistance to fire	EN 13501-2:2010	Clause 3.1.2 of the ETA
BWR 3	Air permeability (material property)	EN 1026:2000	Clause 3.2.1 of the ETA
	Water permeability (material property)	ETAG 026-3, Annex C	Clause 3.2.2 of the ETA
	Content and/or release of dangerous substances	European Council Directive 67/548/EEC and Regulation (EC) No 1272/2008 as well as EOTA TR 034, edition October 2015	Declaration of conformity by the manufacturer
BWR 4	Mechanical resistance and stability	No performance assessed	
	Resistance to impact / movement	No performance assessed	
	Adhesion	EN ISO 11600:2011	Clause 3.3.3 of the ETA
BWR 5	Airborne sound insulation	EN ISO 10140-1:2010	Clause 3.4.1 of the ETA
BWR 6	Thermal properties	No performance assessed	
	Water vapour permeability	No performance assessed	

3.1 Safety in case of fire (BWR 2)

3.1.1 Reaction to fire

“Hilti Firestop Acrylic Sealant CFS-S ACR” was assessed according to ETAG 026-Part 3 clause 2.4.1 and classified according to EN 13501-1:2007.

Component	Class according to EN 13501-1:2010
Hilti Firestop Acrylic Sealant CFS-S ACR	E
Hilti Firestop Round Cord CFS-CO	A1
Backfilling mineral wool	A1
Backfilling material, combustible, based on PE or PU	F

3.1.2 Resistance to fire

“Hilti Firestop Acrylic Sealant CFS-S ACR” has been tested in accordance with EN 1366-4:2010, installed within linear joints in flexible and rigid walls, steel constructions and floors. As backfilling material mineral wool “Rockwool RP-V” and “Terमारock 40” has been used as well as “Hilti Firestop Round Cord CFS-CO”.

Based upon these test results and the field of direct application specified within EN 1366-4:2010, "Hilti Firestop Acrylic Sealant CFS-S ACR" has been classified in accordance with EN 13501-2, as shown in Annex 3 of the ETA.

For details of suitable wall and floor constructions see Annex 3 of the ETA.

3.2 Hygiene, health and environment (BWR 3)

3.2.1 Air permeability

The air permeability of "Hilti Firestop Acrylic Sealant CFS-S ACR" with a thickness of 25 mm on both sides of the wall was tested according to EN 1026:2000 and EN 12211:2000 in an aerated concrete wall. The dimension of the tested joint was 1000 mm x 50 mm.

Up to a pressure difference of 9700 PA no air permeability was measured.

3.2.2 Water permeability

The water permeability has been tested using the principles of the test procedure according to Annex C of ETAG 026-3. The specimen consisted of 2 mm "Hilti Firestop Acrylic Sealant CFS-S ACR" (dry film thickness) on mineral wool. Test result: Water tight to 1000 mm head of water.

3.2.3 Release of dangerous substances

According to the manufacturer's declaration "Hilti Firestop Acrylic Sealant CFS-S ACR" does not contain dangerous substances detailed in Council Directive 67/548/EEC and Regulation (EC) no 1272/2008 as well as EOTA TR 034 (General BWR 3 Checklist for EADs/ETAs – Dangerous substances), edition October 2015 above the acceptable limits.

A written declaration in this respect was submitted by the ETA-holder.

In addition to the specific clauses relating to dangerous substances contained in this European Technical Assessment, there may be other requirements applicable to the products falling within its scope (e.g. transposed European legislation and national laws, regulations and administrative provisions). In order to meet the provisions of the Construction Products Regulation, these requirements need also to be complied with, when and where they apply.

3.3 Safety and accessibility in use (BWR 4)

3.3.1 Mechanical resistance and stability

No performance assessed.

3.3.2 Resistance to impact / movement

No performance assessed.

3.3.3 Adhesion

Adhesion is covered by tests for assessing movement capability according to EN ISO 11600.

3.4 Protection against noise (BWR 5)

3.4.1 Airborne sound insulation

Test reports from noise reduction according to EN ISO 10140-1:2010+A1:2012+A2:2014, EN ISO 10140-2:2010 and EN ISO 717-1:2013 have been provided. The tests were performed in a joint (length 1200mm, depth 100mm, width 25mm) in a rigid wall backfilled with compressed mineral wool. Installation depth of "Hilti Firestop Acrylic Sealant CFS-S ACR" was 12mm on both sides of the wall.

The reached values for the airborne sound insulation are given in the following table.

R_w in dB	C in dB	C_{tr} in dB
64	-2	-7

3.5 Energy economy and heat retention (BWR 6)

3.5.1 Thermal properties

No performance assessed.

3.5.2 Water vapour permeability

No performance assessed.

3.6 General aspects relating to fitness for use

All components of “Hilti Firestop Acrylic Sealant CFS-S ACR” fulfil the requirements for the intended use category.

“Hilti Firestop Acrylic Sealant CFS-S ACR” is therefore appropriate for use at temperatures below 0°C, but with no exposure to rain or UV and can therefore – according to ETAG 026-Part 3 clause 2.4.13.1.1.3 – be categorized as Type Y₂. Since the requirements for Type Y₂ are met, also the requirements for Type Z₁ and Z₂ are fulfilled.

4 Assessment and verification of constancy of performance (hereinafter AVCP) system applied, with reference to its legal base

According to the Decision 1999/454/EC¹, amended by Decision 2001/596/EC² of the European Commission the system(s) of assessment and verification of constancy of performance (see Annex V of Regulation (EU) No 305/2011) is given in the following table.

Product(s)	Intended use(s)	Level(s) or class(es) (resistance to fire)	System of assessment and verification of constancy of performance
Fire Stopping and Fire Sealing Products	for fire compartmentation and/or fire protection or fire performance	any	1

In addition, according to the Decision 1999/454/EC, amended by Decision 2001/596/EC of the European Commission the system(s) of assessment and verification of constancy of performance, with regard to reaction to fire, is 3.

¹ Official Journal of the European Communities no. L 178, 14.7.1999, p. 52

² Official Journal of the European Communities no. L 209, 2.8.2001, p. 33

Product(s)	Intended use(s)	Level(s) or class(es) (reaction to fire)	System of assessment and verification of constancy of performance
Fire Stopping and Fire Sealing Products	For uses subject to regulations on reaction to fire	A1*, A2*, B*, C*	1
		A1**, A2**, B**, C**, D, E	3
		(A1 to E)***, F	4
<p>* Products/materials for which a clearly identifiable stage in the production process results in an improvement of the reaction to fire classification (e.g. an addition of fire retardants or a limiting of organic material)</p> <p>** Products/materials not covered by footnote (*)</p> <p>*** Products/materials that do not require to be tested for reaction to fire (e.g. products/materials of class A1 according to Commission Decision 96/603/EC, as amended)</p>			

5 Technical details necessary for the implementation of the AVCP system, as provided for in the applicable EAD

Technical details necessary for the implementation of the AVCP system are laid down in the control plan deposited with the Technical Assessment Body Österreichisches Institut für Bautechnik.

The notified product certification body shall visit the factory at least once a year for surveillance of the manufacturer.

Issued in Vienna on 04.09.2017
by Österreichisches Institut für Bautechnik

The original document is signed by:

Rainer Mikulits
Managing Director

ANNEX 1

REFERENCE DOCUMENTS AND LIST OF ABBREVIATIONS

1.1 Reference to standards mentioned in the ETA

EN 1026	Windows and doors – Air permeability – Test method
EN 1366-4	Fire resistance tests for service installations - Part 4: Linear joint seals
EN 13501-1	Fire classification of construction products and building elements – Part 1: Classification using test data from reaction to fire tests
EN 13501-2	Fire classification of construction products and building elements – Part 2: Classification using test data from fire resistance tests
EN ISO 717-1	Acoustics – Rating of sound insulation of buildings and of building elements – Part 1: Airborne sound insulation
EN ISO 10140	Acoustics – Laboratory measurement of sound insulation of building elements Part 2: Measurement of airborne sound insulation Part 3: Measurement of impact sound insulation
EN ISO 11600	Building construction — Jointing products — Classification and requirements for sealants

1.2 Other reference documents:

EOTA TR 001	Determination of impact resistance of panels and panel assemblies
EOTA TR 024	Characterisation, Aspects of Durability and Factory Production Control for Reactive Materials, Components and Products
Safety Data Sheet according to 1907/2006/EC, Article 31, for “Hilti Firestop Acrylic Sealant CFS-S ACR”	

1.3 Abbreviations used in drawings

Abbreviation	Description
A, A ₁ , ...	Firestop product CFS-S ACR
B	Backfilling material, inorganic, incombustible
B ₁	Backfilling material, organic, combustible
E	Building element (wall, floor)
t _A	Thickness of sealant
E ₁	steel elements as joint faces
t _B	Thickness of backfilling material
t _E	Thickness of the building element / joint depth
w	Joint width

ANNEX 2

DESCRIPTION OF PRODUCT(S) & PRODUCT LITERATURE

2.1 Hilti Firestop Acrylic Sealant CFS-S ACR

“Hilti Firestop Acrylic Sealant CFS-S ACR” is a 1-component product and is composed essentially of filling substances and an acrylic binder. It is delivered in various colours.

“Hilti Firestop Acrylic Sealant CFS-S ACR” is supplied in 310 ml cartridges, 580 ml foil packs, 5 Liter buckets and 19 Liter buckets.

2.2 Ancillary products

2.2.1 Mineral wool

Mineral wool products suitable for being used as backfilling material

Characteristics	Specification
Stone wool	EN 13162 or EN 14303
Density	39,4 to 100 kg/m ³
Facing	No Al-facing, no other facing
Combustibility class	A1 according EN 13501-1
Melting point	≥ 1000°C

2.3 Hilti Firestop Round Cord CFS-CO

“Hilti Firestop Round Cord CFS-CO” is a rod made from stone wool weaved in glass fibre. It is provided in diameters of 20, 30, 40, 50 and 60 mm to accommodate various joint widths.

A detailed specification of the product is contained in document “Identification / Product Specification and Control Plan of 30.03.2010 relating to the European technical approval ETA-10/0292 and ETA-10/0389 issued on 22.11.2010 Hilti Firestop Round Cord CFS-CO” which is a non-public part of this ETA.

2.4 Combustible backfilling material

Any Polyethylen or Polyurethan based product may be used as backfilling material, covered with “Hilti Firestop Acrylic Sealant CFS-S ACR”. For a more detailed description see Annex 3, clause 3.4.2 of this ETA.

2.5 Technical product literature:

Technical Datasheet and Instructions for Use Hilti Firestop Acrylic Sealant CFS-S ACR (including Hilti Firestop Round Cord CFS-CO)

ANNEX 3

RESISTANCE TO FIRE CLASSIFICATION OF LINEAR JOINT/GAP SEALS MADE FROM “HILTI FIRESTOP ACRYLIC SEALANT CFS-S ACR”

3.1 GENERAL INFORMATION FOR WALL AND FLOOR DESIGN:

3.1.1 Wall / Floor constructions covered:

- a) Flexible walls: The flexible wall construction must be classified in accordance with EN 13501-2 for the required fire resistance period and must have a minimum thickness of 100 mm. The flexible wall construction comprise steel or timber studs lined on both faces with minimum 2 layers of minimum 12.5 mm thick boards.
For timber stud walls there must be a minimum distance of 100 mm of the seal to any stud. The cavity between stud and seal must be closed with an insulation of Class A1 (in accordance with EN 13501-1) for at least 100 mm distance. No joint is closer than 100 mm to next stud.
- b) Rigid walls: The rigid wall must have a minimum thickness of 100 mm and comprise concrete, aerated concrete or masonry, with a minimum density of 550 kg/m³.
- c) Rigid walls: The wall must have a minimum thickness of 150 mm and comprise concrete or masonry, with a minimum density of 2400 kg/m³.
- d) Rigid floors: The floor must have a minimum thickness of 150 mm and comprise aerated concrete or concrete with a minimum density of 2400 kg/m³.
- e) Rigid floors: The floor must have a minimum thickness of 150 mm and comprise aerated concrete with a minimum density of 550 kg/m³.
- f) Steel constructions: The constructions, e.g. columns, beams or joint edges protected by steel angles, must form a minimum seal depth of 150 mm. The steel construction should be made from steel alloys or iron with a melting point higher than 1000°C.

The walls / floors must be classified in accordance with EN 13501-2 for the required fire resistance period.

3.1.2 Joint position and basement preparation

In rigid and flexible wall constructions the joint has to be sealed symmetrically on both sides of the wall. In floor constructions the joint has to be sealed from the top side only.

The following table shows the assessed joint types and the related test and application orientations according to EN 1366-4, Figure 12.

Joint types	Affected clause in the ETA	Tests and application orientation of joint seals
Type IA joint	Annex 3, clause 3.2.1.1	B; vertical linear joint in a vertical test construction
Type IB joint	Annex 3, clause 3.2.1.1	B; vertical linear joint in a vertical test construction
Type II joint	Annex 3, clause 3.2.1.2	A; linear joint in a horizontal test construction
Type III joint	Annex 3, clause 3.2.1.3	D; horizontal wall joint abutting a floor, ceiling or roof
Type IV joint	Annex 3, clause 3.2.2.1	B; vertical linear joint in a vertical test construction
Type V joint	Annex 3, clause 3.2.2.2	A; linear joint in a horizontal test construction
Type VI joint	Annex 3, clause 3.2.3.1	D; horizontal wall joint abutting a floor, ceiling or roof
Type VII joint	Annex 3, clause 3.2.3.2	B; vertical linear joint in a vertical test construction
Type VIII joint	Annex 3, clause 3.2.3.3	B; vertical linear joint in a vertical test construction
Type IX joint	Annex 3, clause 3.3.2.1	B; vertical linear joint in a vertical test construction
Type X joints	Annex 3, clause 3.3.2.2	A; linear joint in a horizontal test construction
Type XI joints	Annex 3, clause 3.3.2.3	D; horizontal wall joint abutting a floor, ceiling or roof
Type XII joint	Annex 3, clause 3.4.3.1	B; vertical linear joint in a vertical test construction
Type XIII joint	Annex 3, clause 3.4.3.2	A; linear joint in a horizontal test construction
Type XIV joint	Annex 3, clause 3.4.3.3	D; horizontal wall joint abutting a floor, ceiling or roof
Type XV joint	Annex 3, clause 3.4.4	A; linear joint in a horizontal test construction
Type XVI joint	Annex 3, clause 3.4.4	A; linear joint in a horizontal test construction

Very porous joint edges have to be cleaned from dust and brittle material first and then pre-treated with “Hilti Firestop Acrylic Sealant CFS-S ACR”, diluted with water, to achieve better adhesion. After a short drying time the sealant should be installed wet-in-wet.

3.2 RESISTANCE TO FIRE CLASSIFICATION OF LINEAR JOINT/GAP SEALS MADE FROM “HILTI FIRESTOP ACRYLIC SEALANT CFS-S ACR” WITH MINERAL WOOL BACKFILLING MATERIAL

3.2.1 “Hilti Firestop Acrylic Sealant CFS-S ACR” in combination with mineral wool products as backfilling material in rigid construction

3.2.1.1 “Hilti Firestop Acrylic Sealant CFS-S ACR” within or between rigid walls

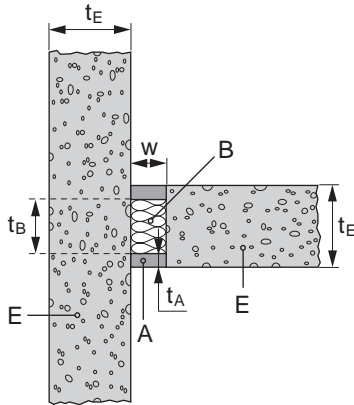
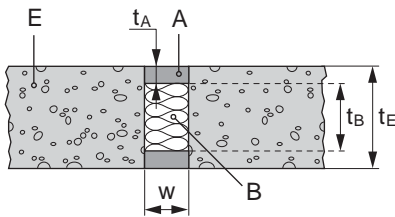
Type I	
Vertical joints in between rigid wall constructions (according to Annex 3, clause 3.1.1.c of this ETA)	
 <p>Type IA (top view)</p>	 <p>Type IB (top view)</p>
<ul style="list-style-type: none"> • A = Hilti Firestop Acrylic Sealant CFS-S ACR • B = mineral wool product (see Annex 2, clause 2.2.1 of this ETA) • $t_E \geq 150$ mm, $t_B \geq 100$ mm • maximum movement capability: $\pm 12,5\%$ • splice distance of insulation minimum 1250 mm 	

For symbols and abbreviations see Annex 1, clause 1.3 of the ETA

For **type IA** and **type IB** joints:

Joint Width (w) (mm)	Joint Depth (t_A) (mm)	Mineral wool Backfilling Compression by (%)	Classification
6 – 20	≥ 6	$\geq 60^a$	EI 180-V-M 12,5-F-W 6 to 20 E 240-V-M 12,5-F-W 6 to 20
20 – 100	≥ 10	$\geq 50^b$	EI 180-V-M 12,5-F-W 20 to 100 E 240-V-M 12,5-F-W 20 to 100

^a Mineral wool has to be pressed into the joint taking into consideration, that the uncompressed thickness of the mineral wool board before installation has to be at least 15mm (for 6mm joint) up to 50mm (for a 20mm joint).

^b Mineral wool has to be pressed into the joint taking into consideration, that the uncompressed thickness of the mineral wool board before installation has to be at least 40mm (for 20mm joint) up to 200mm (for a 100mm joint).

3.2.1.2 “Hilti Firestop Acrylic Sealant CFS-S ACR” within or between rigid floors according to Annex 3, clause 3.1.1 of this ETA

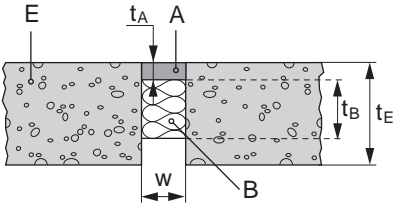
Type II	
Joints in rigid floor constructions	
 <p style="text-align: center;">(sectional view)</p>	
<ul style="list-style-type: none"> • A = Hilti Firestop Acrylic Sealant CFS-S ACR • B = mineral wool products (see Annex 2, clause 2.2.1 of this ETA) • $t_E \geq 150$ mm, $t_B \geq 100$ mm • maximum $\pm 12,5\%$ movement • splice distance minimum 1250 mm 	

For symbols and abbreviations see Annex 1, clause 1.3 of the ETA

For **type II** joints:

Joint Width (w) (mm)	Joint Depth (t_A) (mm)	Mineral wool Backfilling Compression by (%)	Classification
6 – 20	≥ 6	$\geq 60^a$	EI 180-H-M 12,5-F-W 6 to 20 E 180-H-M 12,5-F-W 6 to 20
20 – 100	≥ 10	$\geq 50^b$	EI 120-H-M 12,5-F-W 20 to 100 E 180-H-M 12,5-F-W 20 to 100

^a Mineral wool has to be pressed into the joint taking into consideration, that the uncompressed thickness of the mineral wool board before installation has to be at least 15mm (for 6mm joint) up to 50mm (for a 20mm joint).

^b Mineral wool has to be pressed into the joint taking into consideration, that the uncompressed thickness of the mineral wool board before installation has to be at least 40mm (for 20mm joint) up to 200mm (for a 100mm joint).

3.2.1.3 “Hilti Firestop Acrylic Sealant CFS-S ACR” in combination with mineral wool products in horizontal joints between a rigid wall abutting a floor ceiling or roof

Type III	
Horizontal joints in between a rigid wall, abutting a rigid floor (according to Annex 3, clause 3.1.1.c and 3.1.1.d of this ETA) ceiling or roof	
<p style="text-align: center;">(sectional view)</p>	
<ul style="list-style-type: none"> • A = Hilti Firestop Acrylic Sealant CFS-S ACR • B = mineral wool products (see Annex 2, clause 2.2.1 of this ETA) • $t_E \geq 150$ mm (wall and floor), $t_B \geq 100$ mm • maximum movement capability = $\pm 12,5\%$ • splice distance minimum 1250 mm 	

For symbols and abbreviations see Annex 1, clause 1.3 of the ETA

For **type III** joints:

Joint Width (w) (mm)	Joint Depth (t _A) (mm)	Mineral wool Backfilling Compression by (%)	Classification
6 – 20	≥ 6	≥ 60 ^a	EI 180-T-M 12,5-F-W 6 to 20 E 180-T-M 12,5-F-W 6 to 20
20 – 100	≥ 10	≥ 50 ^b	EI 120-T-M 12,5-F-W 20 to 100 E 180-T-M 12,5-F-W 20 to 100

^a Mineral wool has to be pressed into the joint taking into consideration, that the uncompressed thickness of the mineral wool board before installation has to be at least 15mm (for 6mm joint) up to 50mm (for a 20mm joint).

^b Mineral wool has to be pressed into the joint taking into consideration, that the uncompressed thickness of the mineral wool board before installation has to be at least 40mm (for 20mm joint) up to 200mm (for a 100mm joint).

3.2.2 “Hilti Firestop Acrylic Sealant CFS-S ACR” in combination with mineral wool products as backfilling material in rigid construction with steel elements as joint faces

3.2.2.1 Steel elements as joint faces in linear joints in rigid walls

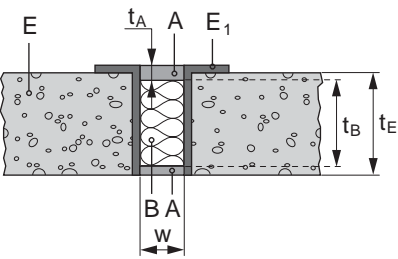
Type IV	
Vertical joints in / between rigid wall constructions (according to Annex 3, clause 3.1.1.c and 3.1.1.f of this ETA)	
 <p style="text-align: center;">(top view)</p>	
<ul style="list-style-type: none"> • A = Hilti Firestop Acrylic Sealant CFS-S ACR • B = mineral wool products (see Annex 2, clause 2.2.1 of this ETA) • $t_E \geq 150$ mm, $t_B \geq 100$ mm • maximum $\pm 7,5\%$ movement (non-movement joints) • maximum splice distance minimum 1250 mm 	

For symbols and abbreviations see Annex 1, clause 1.3 of the ETA

For **Type IV** joints:

Joint Width (w) (mm)	Joint Depth (t _A) (mm)	Mineral wool Backfilling Compression by (%)	Classification
6 – 20	≥ 6	≥ 60 ^a	EI 60-V-X-F-W 6 to 20 E 240-V-X-F-W 6 to 20
20 – 100	≥ 10	≥ 50 ^b	EI 60-V-X-F-W 20 to 100 E 240-V-X-F-W 20 to 100

^a Mineral wool has to be pressed into the joint taking into consideration, that the uncompressed thickness of the mineral wool board before installation has to be at least 15mm (for 6mm joint) up to 50mm (for a 20mm joint).

^b Mineral wool has to be pressed into the joint taking into consideration, that the uncompressed thickness of the mineral wool board before installation has to be at least 40mm (for 20mm joint) up to 200mm (for a 100mm joint).

3.2.2.2 Steel elements as joint faces in horizontal joints in rigid floors

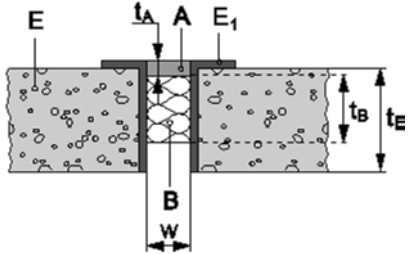
Type V	
Horizontal joints in rigid floor constructions (according to Annex 3, clause 3.1.1.d and 3.1.1.f of this ETA)	
 <p style="text-align: center;">(sectional view)</p>	
<ul style="list-style-type: none"> • A = Hilti Firestop Acrylic Sealant CFS-S ACR • B = mineral wool products (see Annex 2, clause 2.2.1 of this ETA) • $t_B \geq 100$ mm, $t_E \geq 150$ mm • maximum $\pm 7,5\%$ movement (non-movement joints) • maximum splice distance minimum 1250 mm 	

For symbols and abbreviations see Annex 1, clause 1.3 of this ETA

For **type V** joints:

Joint Width (w) (mm)	Joint Depth (t_A) (mm)	Mineral wool Backfilling Compression by (%)	Classification
6 – 20	≥ 6	$\geq 60^a$	EI 120-H-X-F-W 6 to 20 E 120-H-X-F-W 6 to 20
20 – 100	≥ 10	$\geq 50^b$	EI 60- H-X-F-W 20 to 100 E 120-H-X-F-W 20 to 100

^a Mineral wool has to be pressed into the joint taking into consideration, that the uncompressed thickness of the mineral wool board before installation has to be at least 15mm (for 6mm joint) up to 50mm (for a 20mm joint).

^b Mineral wool has to be pressed into the joint taking into consideration, that the uncompressed thickness of the mineral wool board before installation has to be at least 40mm (for 20mm joint) up to 200mm (for a 100mm joint).

3.2.3 “Hilti Firestop Acrylic Sealant CFS-S ACR” in combination with mineral wool products as backfilling material in joints of flexible wall constructions or between flexible wall and rigid construction

3.2.3.1 “Hilti Firestop Acrylic Sealant CFS-S ACR” in combination with mineral wool products in joints between a flexible wall abutting a floor ceiling or roof

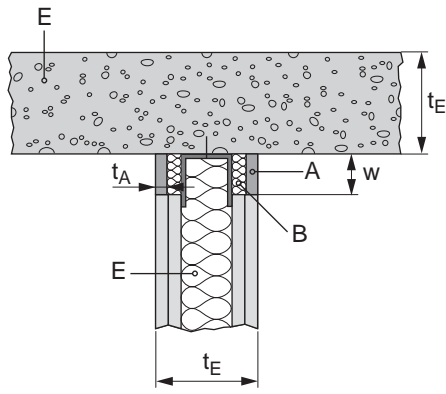
Type VI	
Horizontal joints in between the flexible wall (according to Annex 3, clause 3.1.1.a of the ETA), abutting a floor (according to Annex 3, clause 3.1.1.e of the ETA), ceiling or roof	
 <p>(sectional view)</p>	
<ul style="list-style-type: none"> • A = Hilti Firestop Acrylic Sealant CFS-S ACR • B = mineral wool products (see Annex 2, clause 2.2.1 of this ETA) • Floor: $t_E \geq 150$ mm • Flexible wall: $t_E \geq 100$ mm • Mineral wool E inside the flexible wall (density $\geq 100\text{kg/m}^3$, melting point $\geq 1000^\circ\text{C}$) • maximum joint movement capability: $\pm 12,5\%$ • splice distance minimum 625 mm 	

For symbols and abbreviations see Annex 1, clause 1.3 of the ETA

For **type VI** joints:

Joint Width (w) (mm)	Joint Depth (t _A) (mm)	Mineral wool Backfilling Compression by (%)	Classification
6 – 30	≥ 6	$\geq 60^\circ$	EI 120-T-M 12,5-F-W 6 to 30 E 120-T-M 12,5-F-W 6 to 30

^c Mineral wool has to be pressed into the joint taking into consideration, that the uncompressed thickness of the mineral wool board before installation has to be at least 15mm (for 6mm joint) up to 75mm (for a 30mm joint).

3.2.3.2 “Hilti Firestop Acrylic Sealant CFS-S ACR” in combination with mineral wool products in joints between a flexible wall abutting a rigid wall

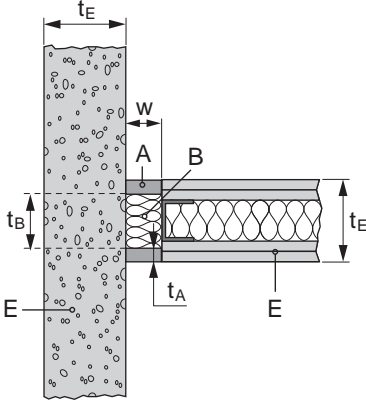
Type VII	
Vertical joints between flexible and rigid wall constructions (according to Annex 3, clause 3.1.1.a and 3.1.1.c of the ETA)	
 <p style="text-align: center;">(top view)</p>	
<ul style="list-style-type: none"> • A = Hilti Firestop Acrylic Sealant CFS-S ACR • B = mineral wool products (see Annex 2, clause 2.2.1 of the ETA) • Rigid wall: $t_E \geq 150$ mm • Flexible wall: $t_E \geq 100$ mm • Mineral wool E inside the flexible wall (density $\geq 100\text{kg/m}^3$, melting point $\geq 1000^\circ\text{C}$) • max. $\pm 7,5\%$ movement (non-movement joints) • splice distance minimum 1250 mm 	

For symbols and abbreviations see Annex 1, clause 1.3 of the ETA

For **type VII** joints:

Joint Width (w) (mm)	Joint Depth (t _A) (mm)	Mineral wool Backfilling Compression by (%)	Classification
10 – 20	≥ 10	$\geq 60^d$	EI 120-V-X-F-W-F-W 10 to 20 E 120-V-X-F-W-F-W 10 to 20

^d Mineral wool has to be pressed into the joint taking into consideration, that the uncompressed thickness of the mineral wool board before installation has to be at least 25mm (for 10mm joint) up to 50mm (for a 20mm joint).

3.2.3.3 “Hilti Firestop Acrylic Sealant CFS-S ACR” in combination with mineral wool backfilling between flexible walls

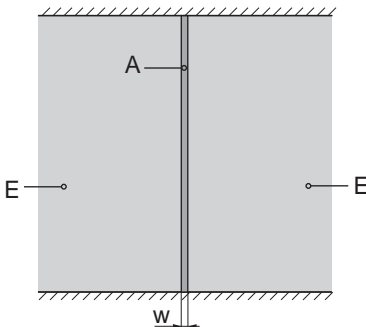
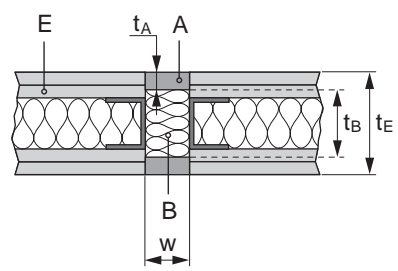
Type VIII	
Vertical joints between flexible wall constructions (according to Annex 3, clause 3.1.1.a of the ETA)	
 <p>(front view)</p>	 <p>(top view)</p>
<ul style="list-style-type: none"> • A = Hilti Firestop Acrylic Sealant CFS-S ACR • B = mineral wool products (see Annex 2, clause 2.2.1 of the ETA) • $t_E \geq 100$ mm • Mineral wool E inside the flexible wall (density $\geq 100\text{kg/m}^3$, melting point $\geq 1000^\circ\text{C}$) • max. $\pm 7,5\%$ movement (non-movement joint) • splice distance minimum 1250 mm 	

For symbols and abbreviations see Annex 1, clause 1.3 of the ETA

For **type VIII** joints:

Joint Width (w) (mm)	Joint Depth (t_A) (mm)	Mineral wool Backfilling Compression by (%)	Classification
10 – 30	≥ 10	$\geq 50^f$	EI 120-V-X-F-W 10 to 30 E 120-V-X-F-W 10 to 30

^f Mineral wool has to be pressed into the joint taking into consideration, that the uncompressed thickness of the mineral wool board before installation has to be at least 20mm (for 10mm joint) up to 60mm (for a 30mm joint).

3.3 RESISTANCE TO FIRE CLASSIFICATION OF LINEAR JOINTS AND GAP SEALS MADE FROM “HILTI FIRESTOP ACRYLIC SEALANT CFS-S ACR” IN COMBINATION WITH “HILTI FIRESTOP ROUND CORD CFS-CO” AS BACKFILLING MATERIAL

3.3.1 Selection of “Hilti Firestop Round Cord CFS-CO” for relevant joint width

The following table is valid identically for joints in/between

- rigid walls, see Annex 3, clause 3.1.1.c of the ETA
- rigid floors, see Annex 3, clause 3.1.1.d of the ETA
- rigid walls abutting a floor ceiling or roof (according Annex 3, clause 3.1.1.c and 3.1.1.d of the ETA)

Joint width (w) (mm)	Size of “Hilti Firestop Round Cord CFS-CO”	Distance of splices in the two “Hilti Firestop Round Cord CFS-CO” rod layers (mm)	
		Vertical joints	Horizontal joints
12 - 17	20	140	645
17 - 27	30	450	645
27 - 37	40	450	645
37 - 47	50	450	645
47 - 55	60	450	645

3.3.2 Joints in rigid walls and floors, backfilled with “Hilti Firestop Round Cord CFS-CO”

Vertical Joints within or between rigid walls according to 3.1.1.c have to be installed identical from both sides of the wall. At least two “Hilti Firestop Round Cords CFS-CO” have to be installed pre-compressed into the joint, running parallel. An air gap has to be maintained between the rods.

3.3.2.1 Joints in/between rigid wall construction, made from “Hilti Firestop Acrylic Sealant CFS-S ACR” with “Hilti Firestop Round Cord CFS-CO”

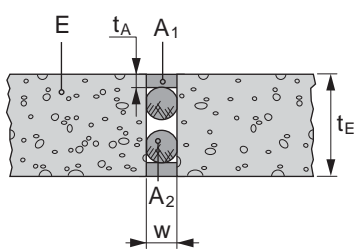
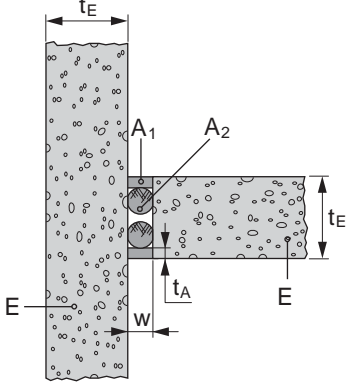
Type IX	
Vertical joints in / between rigid wall constructions (according to Annex 3, clause 3.1.1.c of the ETA)	
 <p>(top view)</p>	 <p>(top view)</p>
<ul style="list-style-type: none"> • A₁ = Hilti Firestop Acrylic Sealant CFS-S ACR, • A₂ = Hilti Firestop Round Cord CFS-CO, • t_E ≥ 150 mm, max. ± 7,5% movement (non-movement joint) 	

For symbols and abbreviations see Annex 1, clause 1.3 of the ETA

For **type IX** joints:

Joint Width (w) (mm)	Joint Depth (t_A) (mm)	Classification
12 – 20	≥ 6	EI 180-V-X-F-W 12 to 55
20 – 55	≥ 10	E 240-V-X-F-W 12 to 55

3.3.2.2 Joints in/between rigid floor construction, made from “Hilti Firestop Acrylic Sealant CFS-S ACR” with “Hilti Firestop Round Cord CFS-CO”

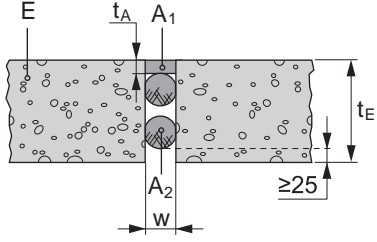
Type X
Joints in floor constructions (according to Annex 3, clause 3.1.1.d of the ETA)
 <p>(sectional view, all measures in mm)</p>
<ul style="list-style-type: none"> • A₁ = Hilti Firestop Acrylic Sealant CFS-S ACR • A₂ = Hilti Firestop Round Cord CFS-CO • t_E ≥ 150 mm, max. ± 7,5% movement (non-movement joint)

For symbols and abbreviations see Annex 1, clause 1.3 of the ETA

For **type X** joints:

Joint Width (w) (mm)	Joint Depth (t_A) (mm)	Classification
12 – 17	≥ 6	EI 180-H-X-F-W 12 to 55
17 – 55	≥ 10	E 180-H-X-F-W 12 to 55

3.3.2.3 Joints in/between rigid floor and wall construction, made from “Hilti Firestop Acrylic Sealant CFS-S ACR” with “Hilti Firestop Round Cord CFS-CO”

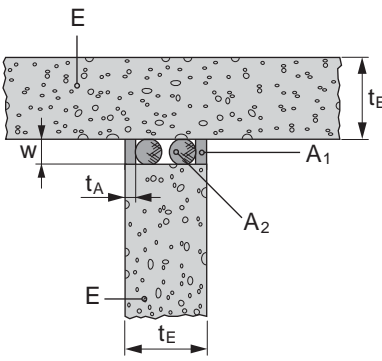
Type XI
Horizontal joints between a rigid wall abutting a rigid floor, ceiling or roof (according to Annex 3, clause 3.1.1.c and 3.1.1.d of the ETA)
 <p style="text-align: center;">(sectional view)</p>
<ul style="list-style-type: none"> • A₁ = Hilti Firestop Acrylic Sealant CFS-S ACR • A₂ = Hilti Firestop Round Cord CFS-CO • t_E ≥ 150 mm • max. ± 7,5% movement (non-movement joint)

For symbols and abbreviations see Annex 1, clause 1.3 of the ETA

For **type XI** joints:

Joint Width(w) (mm)	Joint Depth (t_A) (mm)	Classification
12 – 17	≥ 6	EI 180-T-X-F-W 12 to 55
17 – 55	≥ 10	E 180-T-X-F-W 12 to 55

3.4 RESISTANCE TO FIRE CLASSIFICATION OF LINEAR JOINT/GAP SEALS MADE FROM “HILTI FIRESTOP ACRYLIC SEALANT CFS-S ACR” IN COMBINATION WITH COMBUSTIBLE BACKFILLING MATERIA

3.4.1 Application range for Joints, made from “Hilti Firestop Acrylic Sealant CFS-S ACR” and combustible backfilling material

Within or between:

- rigid wall constructions, see Annex 3, clause 3.1.1.b and 3.1.1.c of the ETA
- rigid floor constructions, see Annex 3, clause 3.1.1.d and 3.1.1.e of the ETA
- between floor and flexible wall constructions ("head of wall joint"), see Annex 3, clause 3.1.1.a and 3.1.1.d of the ETA

3.4.2 Backfilling material B₁ can be:

- any Polyethylene (PE) based material, density ≥ 19,5 kg/m combustibility according to EN 13501-1 class F, E, D, C, B
- any Polyurethane (PU) based material, density ≥ 18,0 kg/m³, combustibility according to EN 13501-1 class F, E, D, C, B
- alternative backfilling material (glass wool, slag/clinker wool, mineral or ceramic wool class A1 according to EN 13501-1

3.4.3 Symmetrical joints

Symmetrical joints show an identical set up (backfilling material and sealing) from both sides of the wall or both sides of the floor.

3.4.3.1 Joints in/between rigid wall construction, made from “Hilti Firestop Acrylic Sealant CFS-S ACR” with combustible backfilling material

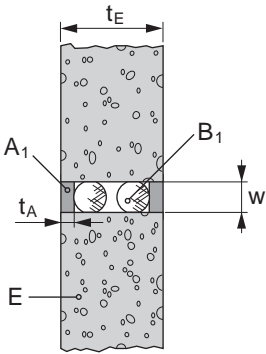
Type XII	
Vertical joints in / between rigid wall constructions (according to Annex 3, clause 3.1.1.b of the ETA)	
 <p style="text-align: center;">(top view)</p>	
<ul style="list-style-type: none"> • A₁ = Hilti Firestop Acrylic Sealant CFS-S ACR • B₁ = combustible backfilling material (see Annex 3, clause 3.4.2 of the ETA) • t_E ≥ 150 mm, splice distance ≥ 100mm 	

For symbols and abbreviations see Annex 1, clause 1.3 of the ETA

For **type XII** joints:

Joint Orientation	Joint width (w) (mm)	Sealant depth (t _A) (mm)	Max. Joint Movement ± (%)	Classification
Vertical joints in / between walls ⁹	6 – 20	10	12,5	EI 180-V-M 12,5-F-W 6 to 20 E 180-V-M 12,5-F-W 6 to 20
	6 – 40	15	12,5	EI 180-V-M 12,5-F-W 6 to 40 E 180-V-M 12,5-F-W 6 to 40
	6 – 35	10	7,5	EI 180-V-X-F-W 6 to 35 E 180-V-X-F-W 6 to 35
	6 – 50	15	7,5	EI 180-V-X-F-W 6 to 50 E 180-V-X-F-W 6 to 50

⁹ Backfilling material can be either PE material, PU material or other, see Annex 3, clause 3.4.2 of the ETA

3.4.3.2 Joints in/between rigid floor construction, made from “Hilti Firestop Acrylic Sealant CFS-S ACR” with combustibile backfilling material

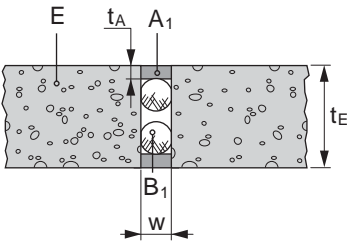
Type XIII	
Horizontal Joints in floor constructions according Annex 3, clause 3.1.1.e of the ETA	
 <p>(sectional view)</p>	
<ul style="list-style-type: none"> • A = Hilti Firestop Acrylic Sealant CFS-S ACR • B₁ = combustibile backfilling material (see Annex 3, clause 3.4.2 of the ETA) • t_E ≥ 150 mm, splice distance minimum 100mm 	

For symbols and abbreviations see Annex 1, clause 1.3 of the ETA

For **Type XIII** joints:

Joint Orientation	Joint width (w) (mm)	Sealant depth (t _A) (mm)	Max. Joint Movement ± (%)	Classification
Joints in floor constructions ⁹	6 – 20	10	12,5	EI 180-H-M 12,5-F-W 6 to 20 E 180-H-M 12,5-F-W 6 to 20
	6 – 40	15	12,5	EI 180-H-M 12,5-F-W 6 to 40 E 180-H-M 12,5-F-W 6 to 40

⁹ Backfilling material can be either PE material, PU material or other, see Annex 3, clause 3.4.2 of the ETA

3.4.3.3 Joints between rigid floor construction and flexible wall construction, made from "Hilti Firestop Acrylic Sealant CFS-S ACR" with combustible backfilling material

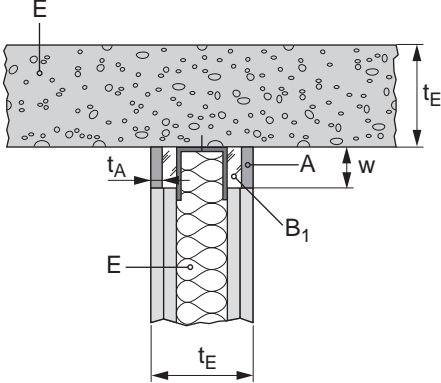
Type XIV	
Horizontal joints between a flexible wall, abutting a floor, ceiling or roof ("head of wall joint"), according to Annex 3, clause 3.1.1.a and 3.1.1.e of the ETA	
 <p style="text-align: center;">(sectional view)</p>	
<ul style="list-style-type: none"> • A = Hilti Firestop Acrylic Sealant CFS-S ACR • B₁ = combustible backfilling material (see Annex 3, clause 3.4.2 of the ETA) • t_E ≥ 150 mm (floor) • t_E ≥ 100 mm (flexible wall) • maximum joint movement capability: ± 12,5%, • Mineral wool E inside the flexible wall (density ≥ 100kg/m³, melting point ≥ 1000°C) • splice distance minimum 200mm 	

For symbols and abbreviations see Annex 1, clause 1.3 of the ETA

For **type XIV** joints:

Joint Orientation	Joint width (w) (mm)	Sealant depth (t_A) (mm)	Max. Joint Movement ± (%)	Classification
Horizontal joints in a wall abutting a floor, ceiling or roof ^h	6 – 20	≥ 10	12,5	EI 90-T-M 12,5-F-W 6 to 20 E 120-T-M 12,5-F-W 6 to 20

^h Backfilling material has to be PE only, see Annex 3, clause 3.4.2 of the ETA

3.4.4 Non-symmetrical Joints

In floor application an asymmetrical joint set up may be chosen, see type XV and type XVI.
In wall application is no asymmetrical system approved.

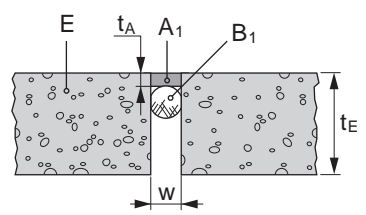
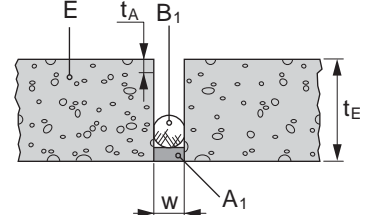
Type XV	Type XVI
Joints in rigid floor constructions, see Annex 3, clause 3.1.1.e of the ETA	Joints in rigid floor constructions, see Annex 3, clause 3.1.1.e of the ETA
 <p>(sectional view)</p> <ul style="list-style-type: none"> • $t_E \geq 150 \text{ mm}$ 	 <p>(sectional view)</p> <ul style="list-style-type: none"> • $t_E \geq 150 \text{ mm}$

For symbols and abbreviations see Annex 1, clause 1.3 of the ETA

For **type XV** and **type XVI** joints:

Joint Orientation	Joint width (w) (mm)	Sealant depth (t _A) (mm)	Backfilling Material B ₁	Max. Joint Movement ± (%)	Classification
Joints in floor constructions (type XV)	6 – 25	15	PE	7,5	EI 120-H-X-F-W 6 to 25 E 180-H-X-F-W 6 to 25
Joints in floor constructions (type XVI)	6 – 25	15	PE	7,5	EI 45-H-X-F-W 6 to 25 E 120-H-X-F-W 6 to 25
Joints in floor constructions (type XV)	6 – 25	15	PU	7,5	EI 120-H-X-F-W 6 to 25 E 180-H-X-F-W 6 to 25
Joints in floor constructions (type XVI)	6 – 25	15	PU	7,5	EI 30-H-X-F-W 6 to 25 E 120-H-X-F-W 6 to 25