

European Technical Approval ETA-04/0027

English translation prepared by DIBt - Original version in German language

Handelsbezeichnung
Trade name

Injektionssystem Hilti HIT-RE 500
Injection System Hilti HIT-RE 500

Zulassungsinhaber
Holder of approval

Hilti Aktiengesellschaft
9494 SCHAAN
FÜRSTENTUM LIECHTENSTEIN

Zulassungsgegenstand
und Verwendungszweck

Verbunddübel in den Größen Ø 8 mm bis Ø 32 mm zur Verankerung
im ungerissenen Beton

*Generic type and use
of construction product*

*Bonded anchor in the sizes of Ø 8 mm to Ø 32 mm for use in
non-cracked concrete*

Geltungsdauer:
Validity: vom
from
bis
to

26 June 2013
16 May 2018

Herstellwerk
Manufacturing plant

Hilti Werke

Diese Zulassung umfasst
This Approval contains

34 Seiten einschließlich 25 Anhänge
34 pages including 25 annexes

Diese Zulassung ersetzt
This Approval replaces

ETA-04/0027 mit Geltungsdauer vom 16.05.2013 bis 16.05.2018
ETA-04/0027 with validity from 16.05.2013 to 16.05.2018

I LEGAL BASES AND GENERAL CONDITIONS

- 1 This European technical approval is issued by Deutsches Institut für Bautechnik in accordance with:
 - Council Directive 89/106/EEC of 21 December 1988 on the approximation of laws, regulations and administrative provisions of Member States relating to construction products¹, modified by Council Directive 93/68/EEC² and Regulation (EC) N° 1882/2003 of the European Parliament and of the Council³;
 - *Gesetz über das In-Verkehr-Bringen von und den freien Warenverkehr mit Bauprodukten zur Umsetzung der Richtlinie 89/106/EWG des Rates vom 21. Dezember 1988 zur Angleichung der Rechts- und Verwaltungsvorschriften der Mitgliedstaaten über Bauprodukte und anderer Rechtsakte der Europäischen Gemeinschaften (Bauproduktengesetz - BauPG) vom 28. April 1998⁴, as amended by Article 2 of the law of 8 November 2011⁵;*
 - Common Procedural Rules for Requesting, Preparing and the Granting of European technical approvals set out in the Annex to Commission Decision 94/23/EC⁶;
 - Guideline for European technical approval of "Metal anchors for use in concrete - Part 5: Bonded anchors", ETAG 001-05.
- 2 Deutsches Institut für Bautechnik is authorized to check whether the provisions of this European technical approval are met. Checking may take place in the manufacturing plant. Nevertheless, the responsibility for the conformity of the products to the European technical approval and for their fitness for the intended use remains with the holder of the European technical approval.
- 3 This European technical approval is not to be transferred to manufacturers or agents of manufacturers other than those indicated on page 1, or manufacturing plants other than those indicated on page 1 of this European technical approval.
- 4 This European technical approval may be withdrawn by Deutsches Institut für Bautechnik, in particular pursuant to information by the Commission according to Article 5(1) of Council Directive 89/106/EEC.
- 5 Reproduction of this European technical approval including transmission by electronic means shall be in full. However, partial reproduction can be made with the written consent of Deutsches Institut für Bautechnik. In this case partial reproduction has to be designated as such. Texts and drawings of advertising brochures shall not contradict or misuse the European technical approval.
- 6 The European technical approval is issued by the approval body in its official language. This version corresponds fully to the version circulated within EOTA. Translations into other languages have to be designated as such.

¹ Official Journal of the European Communities L 40, 11 February 1989, p. 12

² Official Journal of the European Communities L 220, 30 August 1993, p. 1

³ Official Journal of the European Union L 284, 31 October 2003, p. 25

⁴ *Bundesgesetzblatt Teil I 1998*, p. 812

⁵ *Bundesgesetzblatt Teil I 2011*, p. 2178

⁶ Official Journal of the European Communities L 17, 20 January 1994, p. 34

II SPECIFIC CONDITIONS OF THE EUROPEAN TECHNICAL APPROVAL

1 Definition of product and intended use

1.1 Definition of the construction product

The Injection System Hilti HIT-RE 500 for non-cracked concrete is a bonded anchor consisting of a foil pack with injection mortar Hilti HIT-RE 500 and a steel element.

The steel elements are made of zinc coated steel (HIT-V, HAS-(E), and HIS-N), rebar, stainless steel (HIT-V-R, HAS-(E)R, HIS-RN and HZA-R) or high corrosion resistant steel (threaded rods HIT-V-HCR and HAS-(E)HCR).

The steel element is placed into a drilled hole filled with injection mortar and is anchored via the bond between metal part, injection mortar and concrete.

An illustration of the product and intended use is given in Annex 1 and 2.

1.2 Intended use

The anchor is intended to be used for anchorages for which requirements for mechanical resistance and stability and safety in use in the sense of the Essential Requirements 1 and 4 of Council Directive 89/106 EEC shall be fulfilled and failure of anchorages made with these products would cause risk to human life and/or lead to considerable economic consequences. Safety in case of fire (Essential Requirement 2) is not covered in this European technical approval. The anchor is to be used only for anchorages subject to static or quasi-static loading in reinforced or unreinforced normal weight concrete of strength classes C20/25 at minimum and C50/60 at most according to EN 206:2000-12.

The anchor may be used in non-cracked concrete. The anchor may be installed in dry or wet concrete. In case of hammer drilling the anchor may also be installed in flooded holes excepting sea water.

The anchor may be used in the following temperature ranges:

Temperature range I: -40 °C to +40 °C (max long term temperature +24 °C and max short term temperature +40 °C)

Temperature range II: -40 °C to +58 °C (max long term temperature +35 °C and max short term temperature +58 °C)

Temperature range III: -40 °C to +70 °C (max long term temperature +43 °C and max short term temperature +70 °C)

Elements made of zinc coated steel (threaded rods HIT-V and HAS-(E) and internal sleeve HIS-N:

The element made of electroplated or hot-dipped galvanised steel may only be used in structures subject to dry internal conditions.

Elements made of stainless steel (threaded rods HIT-V-R and HAS-(E)R, internal sleeve HIS-RN and Hilti Tension anchor HZA-R):

The element made of stainless steel 1.4401, 1.4404, 1.4439, 1.4571, 1.4578 or 1.4362 may be used in structures subject to dry internal conditions and also in structures subject to external atmospheric exposure (including industrial and marine environment), or exposure to permanently damp internal conditions, if no particular aggressive conditions exist. Such particular aggressive conditions are e.g. permanent, alternating immersion in seawater or the splash zone of seawater, chloride atmosphere of indoor swimming pools or atmosphere with extreme chemical pollution (e.g. in desulphurization plants or road tunnels where de-icing materials are used).

Elements made of high corrosion resistant steel (threaded rods HIT-V-HCR and threaded rods HAS-(E)HCR:

The element made of high corrosion resistant steel 1.4529 or 1.4565 may be used in structures subject to dry internal conditions and also in structures subject to external atmospheric exposure, in permanently damp internal conditions or in other particular aggressive conditions. Such particular aggressive conditions are e.g. permanent, alternating immersion in seawater or the splash zone of seawater, chloride atmosphere of indoor swimming pools or atmosphere with chemical pollution (e.g. in desulphurization plants or road tunnels where de-icing materials are used).

Elements made of reinforcing bars:

Post-installed reinforcing bars acc. to Annex 5 may be used as anchor designed in accordance with the EOTA Technical Report TR 029⁷ only. Such applications are e.g. concrete overlay or shear dowel connections or the connections of a wall predominantly loaded by shear and compression forces with the foundation, where the rebars act as dowels to take up shear forces. Post-installed rebar connections in reinforced concrete structures designed in accordance with EN 1992-1-1:2004 (Eurocode 2) are not covered by this European technical approval.

The provisions made in this European technical approval are based on an assumed working life of the anchor of 50 years. The indications given on the working life cannot be interpreted as a guarantee given by the producer, but are to be regarded only as a means for choosing the right products in relation to the expected economically reasonable working life of the works.

2 Characteristics of the product and methods of verification

2.1 Characteristics of the product

The anchor corresponds to the drawings and provisions given in the Annexes. The characteristic material values, dimensions and tolerances of the anchor not indicated in the Annexes shall correspond to the respective values laid down in the technical documentation⁸ of this European technical approval.

The characteristic values for the design of anchorages are given in the Annexes.

The two components of the injection mortar are delivered in unmixed condition in foil packs of sizes 330 ml, 500 ml or 1400 ml according to Annex 1.

Each foil pack and each steel element is marked in accordance with the specifications given in the Annexes.

Elements made of reinforcing bar shall comply with the specifications given in Annex 5.

The marking of embedment depth for the steel element threaded rod HIT-V and reinforcing bar may be done on jobsite.

2.2 Methods of verification

The assessment of fitness of the anchor for the intended use in relation to the requirements for mechanical resistance and stability and safety in use in the sense of the Essential Requirements 1 and 4 has been made in accordance with the "Guideline for European technical approval of Metal Anchors for Use in Concrete", Part 1 "Anchors in general" and Part 5 "Bonded anchors", on the basis of Option 7.

⁷

The Technical Report TR 029 "Design of bonded anchors" is published in English on EOTA website www.eota.eu.

⁸

The technical documentation of this European technical approval is deposited at the Deutsches Institut für Bautechnik and, as far as relevant for the tasks of the approved bodies involved in the attestation of conformity procedure, is handed over to the approved bodies.

In addition to the specific clauses relating to dangerous substances contained in this European technical approval, there may be other requirements applicable to the products falling within its scope (e.g. transposed European legislation and national laws, regulations and administrative provisions). In order to meet the provisions of the Construction Products Directive, these requirements need also to be complied with, when and where they apply.

3 Evaluation and attestation of conformity and CE marking

3.1 System of attestation of conformity

According to the Decision 96/582/EG of the European Commission⁹ system 2(i) (referred to as System 1) of the attestation of conformity applies.

This system of attestation of conformity is defined as follows:

System 1: Certification of the conformity of the product by an approved certification body on the basis of:

- (a) Tasks for the manufacturer:
 - (1) factory production control;
 - (2) further testing of samples taken at the factory by the manufacturer in accordance with a prescribed test plan;
- (b) Tasks for the approved body:
 - (3) initial type-testing of the product;
 - (4) initial inspection of factory and of factory production control;
 - (5) continuous surveillance, assessment and approval of factory production control.

Note: Approved bodies are also referred to as "notified bodies".

3.2 Responsibilities

3.2.1 Tasks for the manufacturer

3.2.1.1 Factory production control

The manufacturer shall exercise permanent internal control of production. All the elements, requirements and provisions adopted by the manufacturer shall be documented in a systematic manner in the form of written policies and procedures, including records of results performed. This production control system shall insure that the product is in conformity with this European technical approval.

The manufacturer may only use initial/raw/constituent materials stated in the technical documentation of this European technical approval.

The factory production control shall be in accordance with the control plan which is part of the technical documentation of this European technical approval. The control plan is laid down in the context of the factory production control system operated by the manufacturer and deposited at Deutsches Institut für Bautechnik.¹⁰

The results of factory production control shall be recorded and evaluated in accordance with the provisions of the control plan.

⁹ Official Journal of the European Communities L 254 of 08.10.1996.

¹⁰ The control plan is a confidential part of the European technical approval and only handed over to the approved body involved in the procedure of attestation of conformity. See section 3.2.2.

3.2.1.2 Other tasks for the manufacturer

The manufacturer shall, on the basis of a contract, involve a body which is approved for the tasks referred to in section 3.1 in the field of anchors in order to undertake the actions laid down in section 3.2.2 For this purpose, the control plan referred to in sections 3.2.1.1 and 3.2.2 shall be handed over by the manufacturer to the approved body involved.

The manufacturer shall make a declaration of conformity, stating that the construction product is in conformity with the provisions of this European technical approval.

3.2.2 Tasks for the approved bodies

The approved body shall perform the

- initial type-testing of the product,
 - initial inspection of factory and of factory production control,
 - continuous surveillance, assessment and approval of factory production control,
- in accordance with the provisions laid down in the control plan.

The approved body shall retain the essential points of its actions referred to above and state the results obtained and conclusions drawn in a written report.

The approved certification body involved by the manufacturer shall issue an EC certificate of conformity of the product stating the conformity with the provisions of this European technical approval.

In cases where the provisions of the European technical approval and its control plan are no longer fulfilled the certification body shall withdraw the certificate of conformity and inform Deutsches Institut für Bautechnik without delay.

3.3 CE marking

The CE marking shall be affixed on each packaging of the anchor. The letters "CE" shall be followed by the identification number of the approved certification body, where relevant, and be accompanied by the following additional information:

- the name and address of the producer (legal entity responsible for the manufacture),
- the last two digits of the year in which the CE marking was affixed,
- the number of the EC certificate of conformity for the product,
- the number of the European technical approval,
- the number of the guideline for European technical approval,
- use category (ETAG 001-1, Option 7),
- size.

4 Assumptions under which the fitness of the product for the intended use was favourably assessed

4.1 Manufacturing

The European technical approval is issued for the product on the basis of agreed data/information, deposited at Deutsches Institut für Bautechnik, which identifies the product that has been assessed and judged. Changes to the product or production process, which could result in this deposited data/information being incorrect, should be notified to Deutsches Institut für Bautechnik before the changes are introduced. Deutsches Institut für Bautechnik will decide whether or not such changes affect the approval and consequently the validity of the CE marking on the basis of the approval and if so whether further assessment or alterations to the approval shall be necessary.

4.2 Design of anchorages

The fitness of the anchor for the intended use is given under the following conditions:

The anchorages are designed in accordance with the EOTA Technical Report TR 029 "Design of bonded anchors"¹¹ under the responsibility of an engineer experienced in anchorages and concrete work.

Post-installed reinforcing bars may be used as anchor designed in accordance with the EOTA Technical Report TR 029 only. The basic assumptions for the design according to anchor theory shall be observed. This includes the consideration of tension and shear loads and the corresponding failure modes as well as the assumption that the base material (concrete structural element) remains essentially in the serviceability limit state (either non-cracked or cracked) when the connection is loaded to failure. Such applications are e.g. concrete overlay or shear dowel connections or the connections of a wall predominantly loaded by shear and compression forces with the foundation, where the rebars act as dowels to take up shear forces. Connections with reinforcing bars in concrete structures designed in accordance with EN 1992-1-1:2004 (e.g. connection of a wall loaded with tension forces in one layer of the reinforcement with the foundation) are not covered by this European technical approval.

For the internal sleeve only fastening screws or threaded rods made of galvanised steel with the minimum strength class 8.8 EN ISO 898-1 shall be used. The minimum and maximum thread engagement length h_s of the fastening screw or the threaded rod for installation of the fixture shall be met the requirements according to Annex 4, Table 3. The length of the fastening screw or the threaded rod shall be determined depending on thickness of fixture, admissible tolerances, available thread length and minimum and maximum thread engagement length h_s .

Verifiable calculation notes and drawings are prepared taking account of the loads to be anchored.

The position of the anchor is indicated on the design drawings (e.g. position of the anchor relative to reinforcement or to supports, etc.).

¹¹ The Technical Report TR 029 "Design of Bonded Anchors" is published in English on EOTA website www.eota.eu.

4.3 Installation of anchors

The fitness for use of the anchor can only be assumed if the anchor is installed as follows:

- anchor installation carried out by appropriately qualified personnel and under the supervision of the person responsible for technical matters of the site,
- anchor installation in accordance with the manufacturer's specifications and drawings using the tools indicated in the technical documentation of this European technical approval,
- use of the anchor only as supplied by the manufacturer without exchanging the components of an anchor,
- commercial standard threaded rods, washers and hexagon nuts may also be used if the following requirements are fulfilled:
 - material, dimensions and mechanical properties of the metal parts according to the specifications given in Annex 7, Table 6,
 - confirmation of material and mechanical properties of the metal parts by inspection certificate 3.1 according to EN 10204:2004, the documents should be stored,
 - marking of the threaded rod with the envisage embedment depth. This may be done by the manufacturer of the rod or the person on jobsite.
- checks before placing the anchor to ensure that the strength class of the concrete in which the anchor is to be placed is in the range given and is not lower than that of the concrete to which the characteristic loads apply,
- check of concrete being well compacted, e.g. without significant voids,
- marking and keeping the effective anchorage depth,
- edge distance and spacing not less than the specified values without minus tolerances,
- positioning of the drill holes without damaging the reinforcement,
- drilling by hammer-drilling, Hilti hollow drilling or diamond coring,
- in case of aborted drill hole: the drill hole shall be filled with mortar,
- in case of hammer drilling the anchor may also be installed in flooded holes excepting sea water,
- cleaning the drill hole in accordance with Annexes 8 to 12,
- for overhead installation piston plugs shall be used, embedded metal parts shall be fixed during the curing time, e.g. with wedges,
- for injection of the mortar in bore holes ≥ 250 mm piston plugs shall be used,
- the anchor component installation temperature shall be at least $+5$ °C; during curing of the chemical mortar the temperature of the concrete must not fall below $+5$ °C; observing the curing time according to Annex 12, Table 7 until the anchor may be loaded,
- fastening screws or threaded rods (including nut and washer) for the internal sleeves HIS-(R)N must be made of appropriate steel grade and property class,
- installation torque moments are not required for functioning of the anchor. However, the torque moments given in Annexes 3, 4 and 6 must not be exceeded.

5 Recommendations concerning packaging, transport and storage

5.1 Responsibility of the manufacturer

It is in the responsibility of the manufacturer to ensure that the information on the specific conditions according to 1 and 2 including Annexes referred to and 4.2, 4.3 and 5.2 is given to those who are concerned. This information may be made by reproduction of the respective parts of the European technical approval. In addition all installation data shall be shown clearly on the package and/or on an enclosed instruction sheet, preferably using illustration(s).

The minimum data required are:

- drill bit diameter,
- hole depth,
- diameter of steel element,
- minimum effective anchorage depth,
- information on the installation procedure, including cleaning of the hole with the cleaning equipments, preferably by means of an illustration,
- anchor component installation temperature,
- ambient temperature of the concrete during installation of the anchor,
- admissible processing time (open time) of the mortar,
- curing time until the anchor may be loaded as a function of the ambient temperature in the concrete during installation,
- maximum torque moment,
- identification of the manufacturing batch,

All data shall be presented in a clear and explicit form.

5.2 Packaging, transport and storage

The foil packs shall be protected against sun radiation and shall be stored according to the manufacturer's installation instructions in dry condition at temperatures of at least +5 °C to not more than +25 °C.

Foil packs with expired shelf life must no longer be used.

The anchor shall only be packaged and supplied as a complete unit. Foil packs may be packed separately from metal parts.

Uwe Bender
Head of Department

beglaubigt:
Lange

Injection mortar Hilti HIT-RE 500: Epoxy resin system with aggregate

Foil pack 330ml, 500ml and 1.400ml



Static Mixer HILTI HIT-RE-M

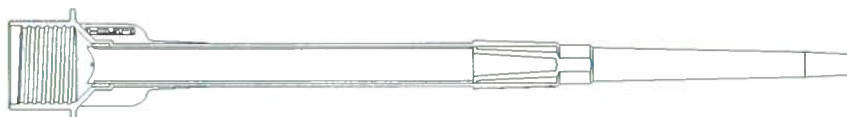

Steel elements



Threaded rod HIT-V-...
thread sizes M8, M10, M12, M16, M20, M24, M27 or M30

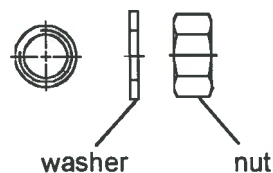

Threaded rod HAS-(E)...
thread sizes M8, M10, M12, M16, M20, M24, M27 or M30

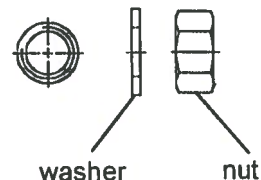

Internal sleeve HIS-(R)N...
thread sizes M8, M10, M12, M16 or M20



Deformed carbon steel bars for concrete reinforcement (rebar)
Ø8, Ø10, Ø12, Ø14, Ø16, Ø20, Ø25, Ø26, Ø28, Ø30 or Ø32



Hilti Tension anchor HZA-R M12, M16, M20 or M24

Injektionssystem Hilti HIT-RE 500

Product

Anhang 1

Installed anchor

Threaded rod HIT-V ...,
HAS-(E)...

Marking of the
embedment
depth

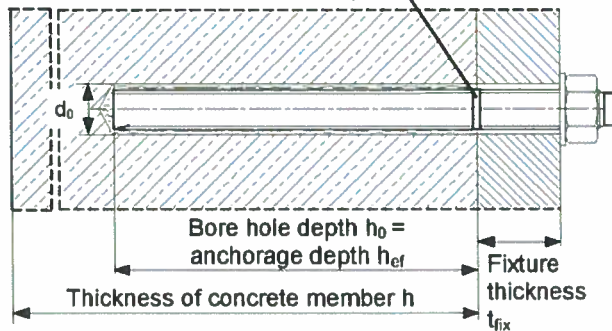

Internal sleeve HIS-(R)N

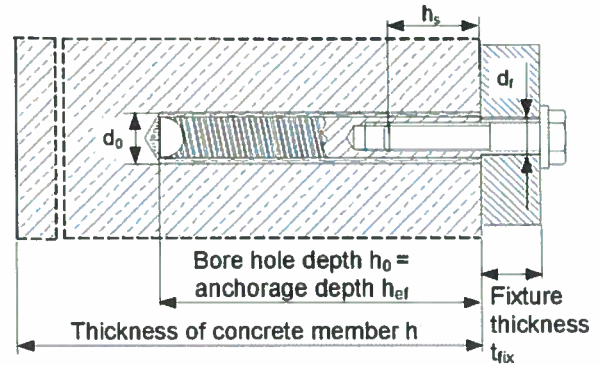

rebar

Marking of the
embedment
depth

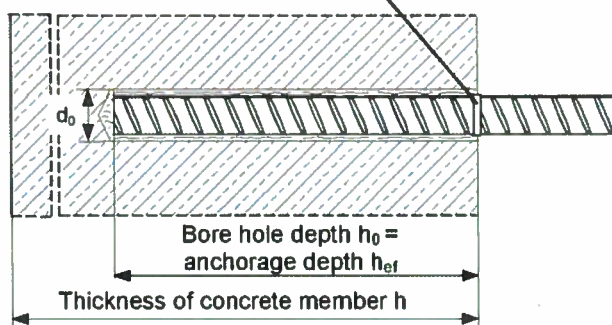

Table 1: Use category

	Drilling method			HIT-RE 500 with ...			
	Hilti hollow drill bit	Hammer drilling	Diamond coring	HIT-V ... HAS-(E)..	Rebar	HIS-N	HZA(-R)
Static and quasi static loading, in non-cracked concrete	✓	✓	✓	Annex 14, 15, 16	Annex 17, 18, 19	Annex 20, 21, 22	Annex 23, 24, 25
Use category	Dry or wet concrete	✓	✓	✓	✓	✓	✓
	Flooded hole(no sea water)	-	✓	-	✓	✓	✓
Installation temperature	+5°C to +40°C						
In-service temperature	Temperature range I:	-40°C to +40°C		(max long term temperature +24°C and max short term temperature +40°C)			
	Temperature range II:	-40°C to +58°C		(max long term temperature +35°C and max short term temperature +58°C)			
	Temperature range III:	-40°C to +70°C		(max long term temperature +43°C and max short term temperature +70°C)			

Injektionssystem Hilti HIT-RE 500

Intended use and use category

Anhang 2

Table 2: Installation data: threaded rod HIT-V-...and HAS-(E)...

HIT-RE 500 with HIT-V-... and HAS-(E)...	M8	M10	M12	M16	M20	M24	M27	M30
Diameter of element d [mm]	8	10	12	16	20	24	27	30
Range of effective anchorage depth h_{ef} and depth of drilled hole h_0 for threaded rod HIT-V-...	min [mm]	40	40	48	64	80	96	108
	max [mm]	160	200	240	320	400	480	600
Effective anchorage depth for threaded rod HAS-(E)...	h_{ef} [mm]	80	90	110	125	170	210	270
Nominal diameter of drill bit d_0 [mm]		10	12	14	18	24	28	30
Diameter of clearance hole in the fixture ¹⁾ $d_f \leq$ [mm]		9	12	14	18	22	26	30
Maximum torque moment T_{max} [Nm]		10	20	40	80	150	200	270
Minimum thickness of concrete member h_{min} [mm]		$h_{ef} + 30 \text{ mm}$ $\geq 100 \text{ mm}$			$h_{ef} + 2 \times d_0$			
Minimum spacing s_{min} [mm]		40	50	60	80	100	120	135
Minimum edge distance c_{min} [mm]		40	50	60	80	100	120	135

¹⁾ for larger clearance hole in the fixture see TR029 section 1.1

Threaded rod HIT-V-...

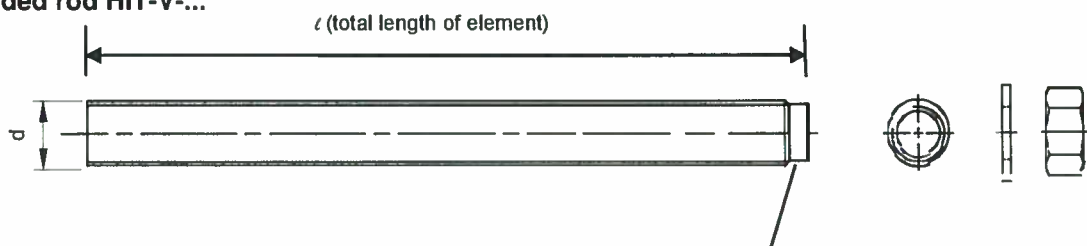

Head marking:

- 5.8 - l = HIT-V-5.8 M...x l
- 5.8F - l = HIT-V-5.8F M...x l
- 8.8 - l = HIT-V-8.8 M...x l
- 8.8F - l = HIT-V-8.8F M...x l
- R - l = HIT-V-R M...x l
- HCR - l = HIT-V-HCR M...x l

Threaded rod HAS-(E)-...

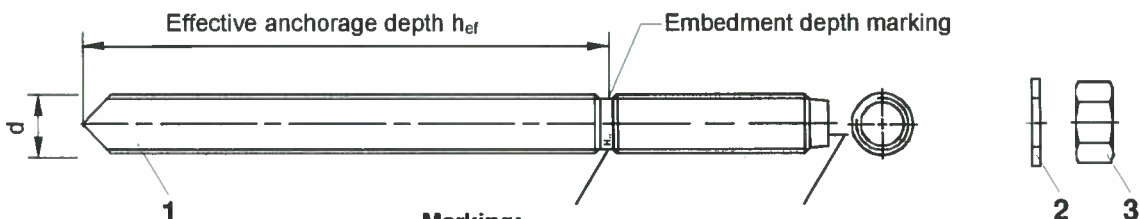

Marking:

- identifying mark - H, embossing "1" HAS-(E)
- identifying mark - H, embossing "=" HAS-(E)R
- identifying mark - H, embossing "CR" HAS-(E)HCR

Injektionssystem Hilti HIT-RE 500

Installation data
Threaded rod HIT-V-...and HAS-(E)...

Anhang 3

Table 3: Installation data: internal sleeve HIS-(R)N

HIT-RE 500 with HIS-(R)N ...			M8	M10	M12	M16	M20
Diameter of element	d	[mm]	12,5	16,5	20,5	25,4	27,6
Effective anchorage depth	h_{ef}	[mm]	90	110	125	170	205
Nominal diameter of drill bit	d_0	[mm]	14	18	22	28	32
Depth of drilled hole	h_0	[mm]	90	110	125	170	205
Diameter of clearance hole in the fixture	$d_f \leq$	[mm]	9	12	14	18	22
Maximum torque moment	T_{max}	[Nm]	10	20	40	80	150
Thread engagement length min-max	h_s	[mm]	8-20	10-25	12-30	16-40	20-50
Minimum thickness of concrete member	h_{min}	[mm]	120	150	170	230	270
Minimum spacing	s_{min}	[mm]	40	45	55	65	90
Minimum edge distance	c_{min}	[mm]	40	45	55	65	90

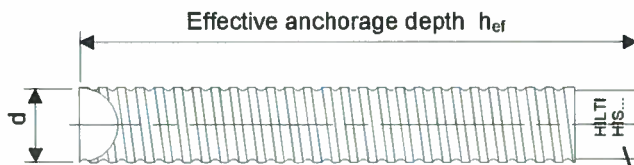

Marking:
Identifying mark - HILTI and
embossing "HIS-N" (for C-steel)
embossing "HIS-RN" (for stainless steel)

Injektionssystem Hilti HIT-RE 500

Installation data
Internal sleeve HIS-(R)N

Anhang 4

Table 4: Installation data: anchor element rebar

HIT-RE 500 with rebar ...			Ø8	Ø10	Ø12	Ø14	Ø16	Ø20	Ø25	Ø26	Ø28	Ø30	Ø32
Diameter of element	d	[mm]	8	10	12	14	16	20	25	26	28	30	32
Range of effective anchorage depth h_{ef} and depth of drilled hole h_o	min	[mm]	60	60	70	80	80	90	100	104	115	120	130
	max	[mm]	160	200	240	280	320	400	500	520	540	600	660
Nominal diameter of drill bit	d_o	[mm]	10 12 ¹⁾	12 14 ¹⁾	14 16 ¹⁾	18	20	25	32	32	35	37 35 ²⁾	40
Minimum thickness of concrete member	h_{min}	[mm]	$h_{ef} + 30 \text{ mm}$ $\geq 100 \text{ mm}$			$h_{ef} + 2 \times d_o$							
Minimum spacing	s_{min}	[mm]	40	50	60	70	80	100	125	130	140	150	160
Minimum edge distance	c_{min}	[mm]	40	50	60	70	80	100	125	130	140	150	160

1) Each of the two given values can be used

2) For diamond coring

Rebar



Refer to EN1992-1-1 Annex C Table C.1 and C.2N Properties of reinforcement:

Product form		Bars and de-coiled rods	
Class		B	C
Characteristic yield strength f_{yk} or $f_{0,2k}$ (MPa)		400 to 600	
Minimum value of $k = (f_t/f_y)k$		$\geq 1,08$	$\geq 1,15$ $< 1,35$
Characteristic strain at maximum force, ϵ_{uk} (%)		$\geq 5,0$	$\geq 7,5$
Bendability		Bend / Rebind test	
Maximum deviation from nominal mass (individual bar) (%)	Nominal bar size (mm) ≤ 8	$\pm 6,0$	
	Nominal bar size (mm) > 8	$\pm 4,5$	
Bond: Minimum relative rib area, $f_{R,min}$ (determination according to EN 15630)	Nominal bar size (mm) 8 to 12	0,040	
	Nominal bar size (mm) > 12	0,056	

Height of the rebar rib h_{rib} :

The height of the rebar rib h_{rib} shall fulfill the following requirement: $0,05 \cdot d \leq h_{rib} \leq 0,07 \cdot d$
with: d = nominal diameter of the rebar element

Injektionssystem Hilti HIT-RE 500

Installation data
Rebar

Anhang 5

Table 5: Installation data:Hilti tension anchor HZA-R

HIT-RE 500 with HZA-R ...			M12	M16	M20	M24
Diameter of the reinforcement bar	d	[mm]	12	16	20	25
Range of embedment depth h_{nom} and depth of drilled hole h_0	min	[mm]	170	180	190	200
	max	[mm]	240	320	400	500
Effective anchorage depth	h_{ef}	[mm]	$h_{nom} - 100$ mm			
Length of smooth shaft	l_e	[mm]	100			
Nominal diameter of drill bit	d_0	[mm]	16	20	25	32
Diameter of clearance hole in the fixture	$d_f \leq$	[mm]	14	18	22	26
Maximum torque moment	T_{max}	[Nm]	40	80	150	200
Minimum thickness of concrete member	h_{min}	[mm]	$h_{nom} + 2 \times d_0$			
Minimum spacing	s_{min}	[mm]	60	80	100	120
Minimum edge distance	c_{min}	[mm]	60	80	100	120

Marking: HZA-R M .. / t_{fix}

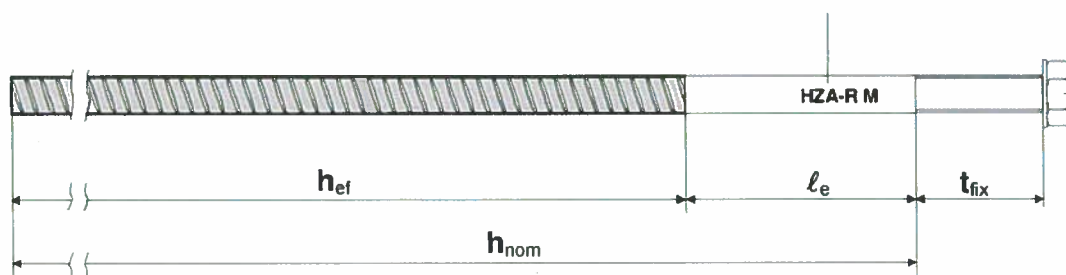

Injektionssystem Hilti HIT-RE 500

Installation data
Hilti tension anchor HZA-R

Anhang 6

Table 6: Materials

Designation	Material
Metal parts made of rebar	
Rebar	See Annex 5
Metal parts made of zinc coated steel	
Threaded rod HIT-V-5.8(F) HAS-(E) M8 to M24	Strength class 5.8 , $R_m = 500 \text{ N/mm}^2$; $R_{p0,2} = 400 \text{ N/mm}^2$, A5 > 8% Ductile Steel galvanized $\geq 5\mu\text{m}$ EN ISO 4042 (F) hot dipped galvanized $\geq 45\mu\text{m}$ EN ISO 10684
Threaded rod HIT-V-8.8(F) HAS-(E) M27 and M30	Strength class 8.8 , $R_m = 800 \text{ N/mm}^2$; $R_{p0,2} = 640 \text{ N/mm}^2$, A5 > 8% Ductile Steel galvanized $\geq 5\mu\text{m}$ EN ISO 4042 (F) hot dipped galvanized $\geq 45\mu\text{m}$ EN ISO 10684
Washer ISO 7089	Steel galvanized EN ISO 4042; hot dipped galvanized EN ISO 10684
Nut EN ISO 4032	Strength class 8 ISO 898-2 Steel galvanized $\geq 5\mu\text{m}$ EN ISO 4042; hot dipped galvanized $\geq 45\mu\text{m}$ EN ISO 10684
Internally threaded Sleeves ¹⁾ HIS-N	Carbon steel 1.0718, EN 10277-3 Steel galvanized $\geq 5\mu\text{m}$ EN ISO 4042
Metal parts made of stainless steel	
Threaded rod HIT-V-R HAS-(E)R	For $\leq \text{M24}$: strength class 70 , $R_m = 700 \text{ N/mm}^2$; $R_{p0,2} = 450 \text{ N/mm}^2$; A5 > 8% Ductile For $> \text{M24}$: strength class 50 , $R_m = 500 \text{ N/mm}^2$; $R_{p0,2} = 210 \text{ N/mm}^2$; A5 > 8% Ductile Stainless steel 1.4401; 1.4404; 1.4578; 1.4571; 1.4439; 1.4362 EN 10088
Washer ISO 7089	Stainless steel 1.4401; 1.4404; 1.4578; 1.4571; 1.4439; 1.4362 EN 10088
Nut EN ISO 4032	Strength class 70 EN ISO 3506-2 Stainless steel 1.4401; 1.4404; 1.4578; 1.4571; 1.4439; 1.4362 EN 10088
Internally threaded sleeves ²⁾ HIS-RN	Stainless steel 1.4401 and 1.4571 EN 10088
Hilti tension anchor HZA-R	Round steel smooth with thread: stainless steel 1.4404, 1.4362 and 1.4571 EN 10088 Rebar B500-B acc. DIN 488-1:2009 and DIN 488-2:2009
Washer ISO 7089	Stainless steel 1.4401; 1.4404; 1.4578; 1.4571; 1.4439; 1.4362 EN 10088
Nut EN ISO 4032	Strength class 70 EN ISO 3506-2 Stainless steel 1.4401; 1.4404; 1.4578; 1.4571; 1.4439; 1.4362 EN 10088
Metal parts made of high corrosion resistant steel	
Threaded rod HIT-V-HCR HAS-(E)HCR	For $\leq \text{M20}$: $R_m = 800 \text{ N/mm}^2$; $R_{p0,2} = 640 \text{ N/mm}^2$, A5 > 8% Ductile For $> \text{M20}$: $R_m = 700 \text{ N/mm}^2$; $R_{p0,2} = 400 \text{ N/mm}^2$, A5 > 8% Ductile High corrosion resistant steel 1.4529, 1.4565 EN 10088
Washer ISO 7089	High corrosion resistant steel 1.4529, 1.4565 EN 10088
Nut EN ISO 4032	Strength class 70 EN ISO 3506-2 High corrosion resistant steel 1.4529, 1.4565 EN 10088

¹⁾ related fastening screw:

strength class 8.8 EN ISO 898-1, A5 > 8% Ductile, steel galvanized $\geq 5\mu\text{m}$ EN ISO 4042

²⁾ related fastening screw:

strength class 70 EN ISO 3506-1, A5 > 8% Ductile, stainless steel 1.4401; 1.4404; 1.4578; 1.4571; 1.4439; 1.4362 EN 10088

Injektionssystem Hilti HIT-RE 500

Materials

Anhang 7

Instruction for use

Bore hole drilling

a) Hilti Hollow drill bit (for dry and wet concrete only)

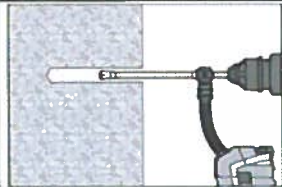

Drill hole to the required embedment depth with an appropriately sized Hilti TE-CD or TE-YD hollow drill bit with Hilti vacuum attachment. This drilling system removes the dust and cleans the bore hole during drilling when used in accordance with the user's manual.
After drilling is complete, proceed to the "injection preparation" step in the instructions for use.

b) Hammer drilling (dry or wet concrete and installation in flooded holes (no sea water))



Drill Hole to the required embedment depth with a hammer drill set in rotation-hammer mode using an appropriately sized carbide drill bit.

c) Diamond coring (for dry and wet concrete only)



Diamond coring is permissible when diamond core drilling machine and the corresponding core bit are used.

Bore hole cleaning Just before setting an anchor, the bore hole must be free of dust and debris.

a) Manual Cleaning (MC)

for bore hole diameters $d_0 \leq 20\text{mm}$ and bore hole depth $h_0 \leq 20d$ or $h_0 \leq 250\text{ mm}$ (d = diameter of element)

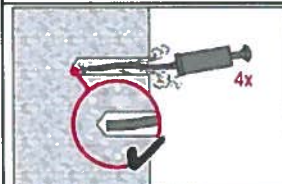

The Hilti manual pump may be used for blowing out bore holes up to diameters $d_0 \leq 20\text{ mm}$ and embedment depths up to $h_{ef} \leq 10d$.

Blow out at least 4 times from the back of the bore hole until return air stream is free of noticeable dust

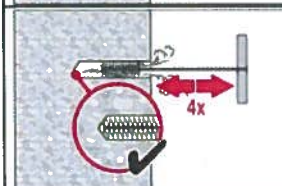

Brush 4 times with the specified brush size (brush $\varnothing \geq$ bore hole \varnothing , see Table 8) by inserting the steel brush Hilti HIT-RB to the back of the hole (if needed with extension) in a twisting motion and removing it.

The brush must produce natural resistance as it enters the bore hole -- if not the brush is too small and must be replaced with the proper brush diameter.

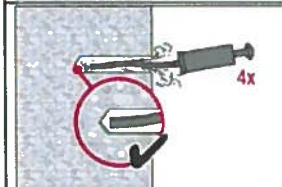

Blow out again with manual pump at least 4 times until return air stream is free of noticeable dust.

Injektionssystem Hilti HIT-RE 500

Instruction for use I

Anhang 8

Bore hole cleaning Just before setting an anchor, the bore hole must be free of dust and debris.

b) Compressed air cleaning (CAC) for all bore hole diameters d_0 and all bore hole depth h_0

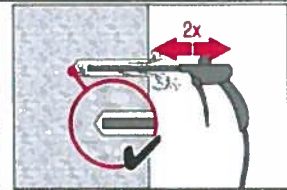

Blow 2 times from the back of the hole (if needed with nozzle extension) over the hole length with oil-free compressed air (min. 6 bar at 6 m³/h) until return air stream is free of noticeable dust.

Bore hole diameter ≥ 32 mm the compressor must supply a minimum air flow of 140 m³/hour.

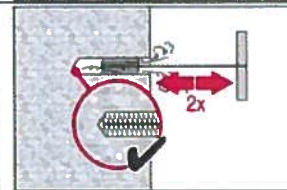

Brush 2 times with the specified brush size (brush $\varnothing \geq$ bore hole \varnothing , see Table 8) by inserting the steel brush Hilti HIT-RB to the back of the hole (if needed with extension) in a twisting motion and removing it.

The brush must produce natural resistance as it enters the bore hole -- if not the brush is too small and must be replaced with the proper brush diameter.

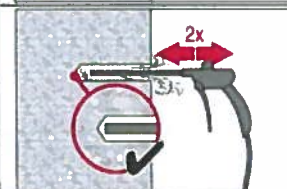

Blow again with compressed air 2 times until return air stream is free of noticeable dust.

c) Cleaning for under water for all bore hole diameters d_0 and all bore hole depth h_0

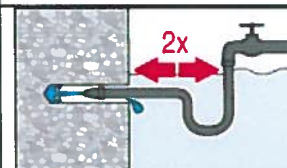

Flush 2 times the hole by inserting a water hose (water-line pressure) to the back of the hole until water runs clear.

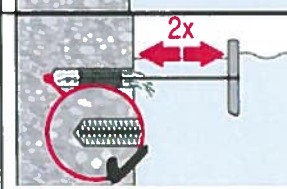

Brush 2 times with the specified brush size (brush $\varnothing \geq$ bore hole \varnothing , see Table 8) by inserting the steel brush Hilti HIT-RB to the back of the hole (if needed with extension) in a twisting motion and removing it.

The brush must produce natural resistance as it enters the bore hole -- if not the brush is too small and must be replaced with the proper brush diameter.

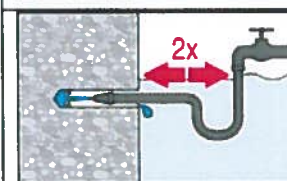

Flush again 2 times the hole by inserting a water hose (water-line pressure) to the back of the hole until water runs clear.

Injektionssystem Hilti HIT-RE 500

Instruction for use II

Anhang 9

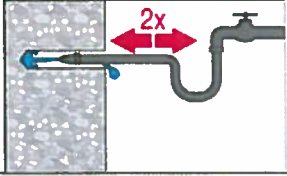
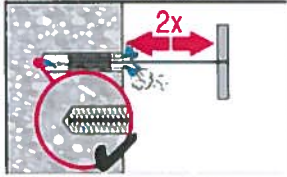
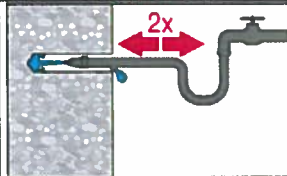
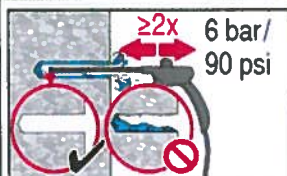
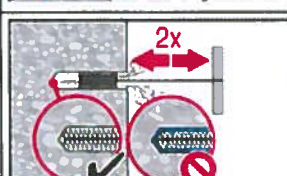
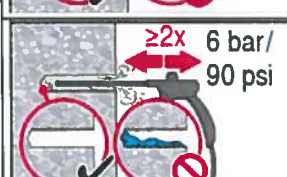
Bore hole cleaning Just before setting an anchor, the bore hole must be free of dust and debris.	
d) Cleaning of hammer drilled flooded holes and diamond cored holes for all bore hole diameters d_0 and all bore hole depth h_0	
	Flush 2 times the hole by inserting a water hose (water-line pressure) to the back of the hole until water runs clear.
	Brush 2 times with the specified brush size (brush $\varnothing \geq$ bore hole \varnothing , see Table 8) by inserting the steel brush Hilti HIT-RB to the back of the hole (if needed with extension) in a twisting motion and removing it. The brush must produce natural resistance as it enters the bore hole -- if not the brush is too small and must be replaced with the proper brush diameter.
	Flush 2 times the hole by inserting a water hose (water-line pressure) to the back of the hole until water runs clear.
	Blow 2 times from the back of the hole (if needed with nozzle extension) over the hole length with oil-free compressed air (min. 6 bar at 6 m ³ /h) until return air stream is free of noticeable dust and water. Bore hole diameter \geq 32 mm the compressor must supply a minimum air flow of 140 m ³ /hour.
	Brush 2 times with the specified brush size (brush $\varnothing \geq$ bore hole \varnothing , see Table 8) by inserting the steel brush Hilti HIT-RB to the back of the hole (if needed with extension) in a twisting motion and removing it. The brush must produce natural resistance as it enters the bore hole -- if not the brush is too small and must be replaced with the proper brush diameter.
	Blow again with compressed air 2 times until return air stream is free of noticeable dust and water.
Injektionssystem Hilti HIT-RE 500	
Instruction for use III	
Anhang 10	

Injection preparation

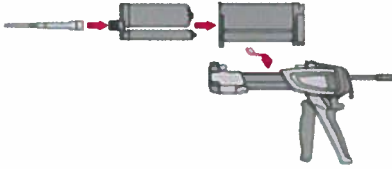

Tightly attach new Hilti mixing nozzle HIT-RE-M to foil pack manifold (snug fit). Do not modify the mixing nozzle.
Observe the instruction for use of the dispenser and the mortar.
Check foil pack holder for proper function. Do not use damaged foil packs / holders.
Insert foil pack into foil pack holder and put holder into HIT-dispenser.

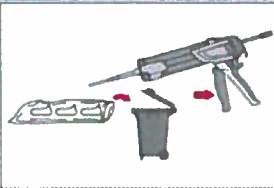

The foil pack opens automatically as dispensing is initiated. Discard initial adhesive. Depending on the size of the foil pack an initial amount of adhesive has to be discarded.
Discard quantities are

3 strokes	for 330 ml foil pack,
4 strokes	for 500 ml foil pack,
65 ml	for 1400 ml foil pack

Inject adhesive from the back of the borehole without forming air voids

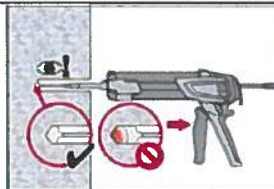

Inject the adhesive starting at the back of the hole, slowly withdrawing the mixer with each trigger pull.
Fill holes approximately 2/3 full. It is required that the annular gap between the anchor and the concrete is completely filled with adhesive along the embedment length.



After injection is completed, depressurize the dispenser by pressing the release trigger. This will prevent further adhesive discharge from the mixer.

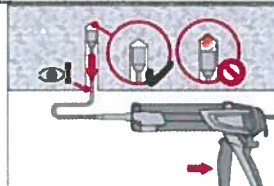

Overhead installation and/or installation with embedment depth $h_{ef} > 250\text{mm}$.
For overhead installation the injection is only possible with the aid of extensions and piston plugs. Assemble HIT-RE-M mixer, extension(s) and appropriately sized piston plug HIT-SZ (see Table 8). Insert piston plug to back of the hole and inject adhesive. During injection the piston plug will be naturally extruded out of the bore hole by the adhesive pressure.

Under water application: fill bore hole completely with mortar

Injektionssystem Hilti HIT-RE 500

Instruction for use IV

Anhang 11

Setting the element

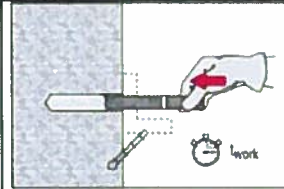

Before use, verify that the element is dry and free of oil and other contaminants.
Mark and set element to the required embedment depth until working time t_{work} has elapsed. The working time t_{work} is given in Table 7.

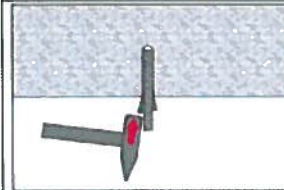

For overhead installation use piston plugs and fix embedded parts with e.g. wedges HIT-OHW.

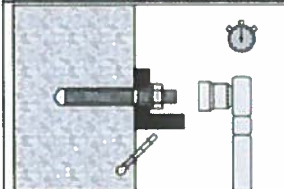

Loading the anchor:
After required curing time t_{cure} (see Table 7) the anchor can be loaded.
The applied installation torque shall not exceed the values T_{max} given in Tables 2, 3 and 5.

Table 7: Working time t_{work} and minimum curing time t_{cure}









Temperature in the anchorage base [°C]	Maximum working time t_{work} [min]	Minimum curing time t_{cure} [h]
5 to 9	120	72
10 to 14	90	48
15 to 19	30	24
20 to 29	20	12
30 to 39	12	8
40	12	4

Injektionssystem Hilti HIT-RE 500

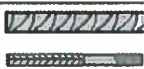

Instruction for use V
Working time and minimum curing time

Anhang 12

Table 8: Borehole diameter specific installation tools

Elements			Drill and clean				Installation
HIT-V ... HAS-(E) ...	HIS-N	Rebar - HZA(-R)	Hilti hollow drill bit TE-CD TE-YD	Hammer drilling TE-C TE-Y	Diamond coring	Brush	Piston plug
							
[mm]	[mm]	[mm]	d ₀ [mm]	d ₀ [mm]	d ₀ [mm]	HIT-RB	HIT-SZ
8	-	8	-	10	10	10	-
10	-	8 / 10	12	12	12	12	12
12	8	10 / 12	14	14	14	14	14
-	-	12	16	16	16	16	16
16	10	14	18	18	18	18	18
-	-	16	20	20	20	20	20
-	12	-	22	22	22	22	22
20	-	-	24	24	24	24	24
-	-	20	25	25	25	25	25
24	16	-	28	28	28	28	28
27	-	-	-	30	30	30	30
-	20	25 / 26	32	32	32	32	32
30	-	28	-	35	35	35	35
-	-	30	-	37	37	37	37
-	-	32	-	40	40	40	40

Cleaning alternatives

<p>Automatic cleaning with Hilti hollow drill bit: Cleaning is performed during drilling with Hilti TE-CD and TE-YD drilling system including vacuum cleaner.</p>	
<p>Manual Cleaning (MC): Hilti hand pump for blowing out bore holes with diameters d₀ ≤ 20 mm and bore hole depth h₀ ≤ 10d</p>	
<p>Compressed air cleaning (CAC): Air nozzle with an orifice opening of minimum 3,5 mm in diameter.</p>	

Injektionssystem Hilti HIT-RE 500

Borehole diameter specific installation tools
Cleaning alternatives

Anhang 13

Table 9: Characteristic tension resistance of threaded rod HIT-V... and HAS-(E)...

HIT-RE 500 with HIT-V... and HAS-(E)...		M8	M10	M12	M16	M20	M24	M27	M30	
Steel failure HIT-V...										
Char. resistance HIT-V 5.8(F) $N_{Rk,s}$	[kN]	18	29	42	79	123	177	230	281	
Char. resistance HIT-V 8.8(F) $N_{Rk,s}$	[kN]	29	46	67	126	196	282	367	449	
Partial safety factor $\gamma_{Ms,N}^{1)}$	[-]	1,5								
Char. resistance HIT-V R $N_{Rk,s}$	[kN]	26	41	59	110	172	247	230	281	
Partial safety factor $\gamma_{Ms,N}^{1)}$	[-]	1,87							2,86	
Char. resistance HIT-V HCR $N_{Rk,s}$	[kN]	29	46	67	126	196	247	321	393	
Partial safety factor $\gamma_{Ms,N}^{1)}$	[-]	1,5					2,1			
Steel failure HAS-(E)...										
Char. resistance HAS $N_{Rk,s}$	[kN]	17	26	38	72	112	160	347	422	
Partial safety factor $\gamma_{Ms,N}^{1)}$	[-]	1,5								
Char. resistance HAS-R $N_{Rk,s}$	[kN]	23	37	53	101	157	224	217	263	
Partial safety factor $\gamma_{Ms,N}^{1)}$	[-]	1,87							2,86	
Char. resistance HAS-HCR $N_{Rk,s}$	[kN]	27	42	61	115	180	224	304	369	
Partial safety factor $\gamma_{Ms,N}^{1)}$	[-]	1,5					2,1			
Combined pullout and concrete cone failure ⁴⁾										
Diameter of element d	[mm]	8	10	12	16	20	24	27	30	
Characteristic bond resistance in non-cracked concrete C20/25 with Hilti hollow drill bit or hammer drilling										
Temp. range I: 40°C/24°C $\tau_{Rk,ucr}$	[N/mm ²]	16	16	16	15	15	14	14	13	
Temp. range II: 58°C/35°C $\tau_{Rk,ucr}$	[N/mm ²]	13	13	13	12	12	11	11	11	
Temp. range III: 70°C/43°C $\tau_{Rk,ucr}$	[N/mm ²]	8	8	8	7,5	7	7	6,5	6,5	
Characteristic bond resistance in non-cracked concrete C20/25 with diamond coring										
Temp. range I: 40°C/24°C $\tau_{Rk,ucr}$	[N/mm ²]	13	13	13	12	11	10	9	8,5	
Temp. range II: 58°C/35°C $\tau_{Rk,ucr}$	[N/mm ²]	11	11	11	9,5	9	8	7	6,5	
Temp. range III: 70°C/43°C $\tau_{Rk,ucr}$	[N/mm ²]	6,5	6,5	6,5	5,5	5	4,5	4,5	4	
Increasing factors for τ_{Rk}	ψ_c	C30/37					1,04			
		C40/50					1,07			
		C50/60					1,09			
Splitting failure ⁴⁾										
Edge distance $c_{cr,sp}$ [mm] for		$h / h_{ef}^{6)} \geq 2,0$		$1,0 \cdot h_{ef}$						
		$2,0 > h / h_{ef}^{6)} > 1,3$		$4,6 h_{ef} - 1,8 h$						
		$h / h_{ef}^{6)} \leq 1,3$		$2,26 h_{ef}$						
Spacing	$s_{cr,sp}$	[mm] $2 \times c_{cr,sp}$								
Partial safety factors for combined pullout, concrete cone and splitting failure, holes drilled by:										
Hilti hollow drill bit:	$\gamma_{Mp} = \gamma_{Mc} = \gamma_{Msp}^{1)}$	[-]	1,8 ²⁾			2,1 ³⁾				
Hammer drilling:	$\gamma_{Mp} = \gamma_{Mc} = \gamma_{Msp}^{1)}$	[-]	2,1 ³⁾							
Diamond coring:	$\gamma_{Mp} = \gamma_{Mc} = \gamma_{Msp}^{1)}$	[-]	1,8 ²⁾			2,1 ³⁾				

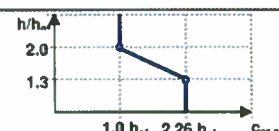

¹⁾ In absence of other national regulations

³⁾ The partial safety factor $\gamma_2 = 1,4$ is included.

⁵⁾ Explanation in chapter 1.2

²⁾ The partial safety factor $\gamma_2 = 1,2$ is included.

⁴⁾ Calculation of concrete failure and splitting see chapter 4.2.1

⁶⁾ h = base material thickness; h_{ef} = anchorage depth

Injektionssystem Hilti HIT-RE 500

Characteristic tension resistance
of threaded rod HIT-V and HAS-(E)

Anhang 14

Table 10: Characteristic shear resistance of threaded rod HIT-V... and HAS-(E)...

HIT-RE 500 with HIT-V... and HAS-(E)...		M8	M10	M12	M16	M20	M24	M27	M30
Steel failure without lever arm ³⁾									
Char. Resistance HIT-V 5.8(F)	$V_{Rk,s}$ [kN]	9	15	21	39	61	88	115	140
Char. Resistance HIT-V 8.8(F)	$V_{Rk,s}$ [kN]	15	23	34	63	98	141	184	224
Char. Resistance HIT-V R	$V_{Rk,s}$ [kN]	13	20	30	55	86	124	115	140
Char. Resistance HIT-V HCR	$V_{Rk,s}$ [kN]	15	23	34	63	98	124	161	196
Char. Resistance HAS	$V_{Rk,s}$ [kN]	8,5	13	19	36	56	80	174	211
Char. Resistance HAS- R	$V_{Rk,s}$ [kN]	12	19	27	51	79	112	108	132
Char. Resistance HAS- HCR	$V_{Rk,s}$ [kN]	13	21	31	58	90	112	152	184
Steel failure with lever arm									
Char. Resistance HIT-V 5.8(F)	$M^0_{Rk,s}$ [Nm]	19	37	66	167	325	561	832	1125
Char. Resistance HIT-V 8.8(F)	$M^0_{Rk,s}$ [Nm]	30	60	105	266	519	898	1332	1799
Char. Resistance HIT-V R	$M^0_{Rk,s}$ [Nm]	26	52	92	233	454	786	832	1124
Char. Resistance HIT-V HCR	$M^0_{Rk,s}$ [Nm]	30	60	105	266	520	786	1165	1574
Char. Resistance HAS	$M^0_{Rk,s}$ [Nm]	16	33	56	147	284	486	1223	1637
Char. Resistance HAS- R	$M^0_{Rk,s}$ [Nm]	23	45	79	205	398	680	764	1023
Char. Resistance HAS- HCR	$M^0_{Rk,s}$ [Nm]	26	52	90	234	455	680	1070	1433
Partial safety factors for steel failure									
HIT-V 5.8(F) or HIT-V 8.8 (F) or HAS	$\gamma_{Ms,V}$ ¹⁾ [-]	1,25							
HIT-V R or HAS-R	$\gamma_{Ms,V}$ ¹⁾ [-]	1,56						2,38	
HIT-V HCR or HAS-HCR	$\gamma_{Ms,V}$ ¹⁾ [-]	1,25					1,75		
Concrete pry-out failure									
Factor in equation (5.7) of Technical Report TR 029 for the design of bonded anchors	k [-]	1,0 ($h_{ef} < 60\text{mm}$) 2,0 ($h_{ef} \geq 60\text{mm}$)							
Partial safety factor	$\gamma_{Mcp,V}$ ¹⁾ [-]	1,5 ²⁾							
Concrete edge failure									
See chapter 5.2.3.4 of Technical Report TR 029 for the design of bonded anchors									
Partial safety factor	γ_{Mc} [-]	1,5 ²⁾							

¹⁾ In absence of national regulations

²⁾ The partial safety factor $\gamma_2 = 1,0$ is included.

³⁾ Acc. to chapter 4.2.2 commercial standard rods that fulfill the ductility requirement $A_5 > 8\%$ (see table 6) can be used only

Injektionssystem Hilti HIT-RE 500

Characteristic shear resistance
of threaded rod HIT-V and HAS-(E)

Anhang 15

Table 11: Displacements under tension load ¹⁾ of threaded rod HIT-V... and HAS-(E)...

HIT-RE 500 with HIT-V... and HAS-(E)...	M8	M10	M12	M16	M20	M24	M27	M30	
Non-cracked concrete, temperature range I ²⁾ : 40°C/24°C									
Displacement	δ_{N0} [mm/(N/mm ²)]	0,02	0,02	0,03	0,04	0,05	0,06	0,06	0,07
	$\delta_{N\infty}$ [mm/(N/mm ²)]	0,04	0,05	0,06	0,08	0,11	0,13	0,15	0,17
Non-cracked concrete, temperature range II ²⁾ : 58°C/35°C									
Displacement	δ_{N0} [mm/(N/mm ²)]	0,03	0,04	0,05	0,07	0,09	0,11	0,13	0,14
	$\delta_{N\infty}$ [mm/(N/mm ²)]	0,07	0,09	0,10	0,14	0,18	0,22	0,25	0,28
Non-cracked concrete, temperature range III ²⁾ : 70°C/43°C									
Displacement	δ_{N0} [mm/(N/mm ²)]	0,07	0,09	0,10	0,14	0,18	0,22	0,25	0,28
	$\delta_{N\infty}$ [mm/(N/mm ²)]	0,09	0,12	0,15	0,20	0,26	0,31	0,35	0,40

¹⁾ Calculation of displacement under service load: τ_{sd} design value of bond stress

Displacement under short term loading = $\delta_{N0} \times \tau_{sd} / 1,4$

Displacement under long term loading = $\delta_{N\infty} \times \tau_{sd} / 1,4$

²⁾ Explanation see chapter 1.2

Table 12: Displacements under shear load ¹⁾ of threaded rod HIT-V... and HAS-(E)...

HIT-RE 500 with HIT-V... and HAS-(E)...	M8	M10	M12	M16	M20	M24	M27	M30	
Displacement	δ_{V0} [mm/kN]	0,06	0,06	0,05	0,04	0,04	0,03	0,03	0,03
	$\delta_{V\infty}$ [mm/kN]	0,09	0,08	0,08	0,06	0,06	0,05	0,05	0,05

¹⁾ Calculation of displacement under service load: V_{sd} design value of shear load

Displacement under short term loading = $\delta_{V0} \times V_{sd} / 1,4$

Displacement under long term loading = $\delta_{V\infty} \times V_{sd} / 1,4$

Injektionssystem Hilti HIT-RE 500

Displacements of threaded rod HIT-V and HAS-(E)

Anhang 16

Table 13: Characteristic tension resistance of rebar

HIT-RE 500 with rebar...	Ø8	Ø10	Ø12	Ø14	Ø16	Ø20	Ø25	Ø26	Ø28	Ø30	Ø32		
Steel failure													
Characteristic resistance for rebar B500B acc. to DIN 488:2009-08 ⁷⁾	$N_{Rk,s}$	[kN]	28	43	62	85	111	173	270	-	339	-	442
Partial safety factor for rebar B500B acc. to DIN 488:2009-08 ⁸⁾	$\gamma_{Ms,N}$ ¹⁾	[-]	1,4						-	1,4	-	1,4	
Combined pullout and concrete cone failure ⁴⁾													
Diameter of element	d	[mm]	8	10	12	14	16	20	25	26	28	30	32
Characteristic bond resistance in non-cracked concrete C20/25 with Hilti hollow drill bit or hammer drilling													
Temp. range I ⁵⁾ : 40°C/24°C	$\tau_{Rk,ucr}$	[N/mm ²]	15	15	15	14	14	14	13	13	13	13	13
Temp. range II ⁵⁾ : 58°C/35°C	$\tau_{Rk,ucr}$	[N/mm ²]	12	12	12	12	11	11	11	11	10	10	10
Temp. range III ⁵⁾ : 70°C/43°C	$\tau_{Rk,ucr}$	[N/mm ²]	7	7	7	7	7	6,5	6,5	6,5	6	6	6
Characteristic bond resistance in non-cracked concrete C20/25 with diamond coring													
Temp. range I ⁵⁾ : 40°C/24°C	$\tau_{Rk,ucr}$	[N/mm ²]	12	12	12	11	11	10	8,5	8,5	8	7,5	7
Temp. range II ⁵⁾ : 58°C/35°C	$\tau_{Rk,ucr}$	[N/mm ²]	9,5	9,5	9,5	9	8,5	8	7	6,5	6,5	6	5,5
Temp. range III ⁵⁾ : 70°C/43°C	$\tau_{Rk,ucr}$	[N/mm ²]	6	6	6	5,5	5	4,5	4	4	3,5	3,5	3,5
Increasing factors for τ_{Rk}	ψ_c	C30/37							1,04				
		C40/50							1,07				
		C50/60							1,09				
Splitting failure ⁴⁾													
Edge distance $c_{cr,sp}$ [mm] for	$h / h_{ef} \geq 2,0$		$1,0 \cdot h_{ef}$										
	$2,0 > h / h_{ef} > 1,3$		$4,6 h_{ef} - 1,8 h$										
	$h / h_{ef} \leq 1,3$		$2,26 h_{ef}$										
Spacing $s_{cr,sp}$ [mm]			$2 \times c_{cr,sp}$										
Partial safety factors for combined pullout, concrete cone and splitting failure, holes drilled by:													
Hilti hollow drill bit:	$\gamma_{Mp} = \gamma_{Mc} = \gamma_{Msp}$ ¹⁾	[-]	1,8 ²⁾				2,1 ³⁾						
Hammer drilling:	$\gamma_{Mp} = \gamma_{Mc} = \gamma_{Msp}$ ¹⁾	[-]	2,1 ⁵⁾										
Diamond coring:	$\gamma_{Mp} = \gamma_{Mc} = \gamma_{Msp}$ ¹⁾	[-]	1,8 ²⁾				2,1 ³⁾						

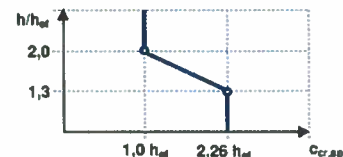

- ¹⁾ In absence of other national regulations
²⁾ The partial safety factor $\gamma_2 = 1,2$ is included.
³⁾ The partial safety factor $\gamma_2 = 1,4$ is included.
⁴⁾ Calculation of concrete failure and splitting see chapter 4.2.1
⁵⁾ Explanation in section 1.2
⁶⁾ h = base material thickness; h_{ef} = anchorage depth
⁷⁾ The characteristic tension resistance $N_{Rk,s}$ for rebars that do not fulfil the requirements acc. DIN 488 shall be calculated acc. Technical Report TR 029, Equation (5.1)
⁸⁾ The partial safety factor $\gamma_{Ms,N}$ for rebars that do not fulfil the requirements acc. DIN 488 shall be calculated acc. Technical Report TR 029, Equation (3.3a)

Injektionssystem Hilti HIT-RE 500

Characteristic tension resistance of rebar

Anhang 17

Table 14: Characteristic shear resistance of rebar

HIT-RE 500-SD with rebar...		Ø8	Ø10	Ø12	Ø14	Ø16	Ø20	Ø25	Ø26	Ø28	Ø30	Ø32
Steel failure without lever arm												
Characteristic resistance for rebar B500B acc. to DIN 488:2009-08 ³⁾	$V_{Rk,s}$ [kN]	14	22	31	42	55	86	135	-	169	-	221
Steel failure with lever arm												
Characteristic resistance for rebar B500B acc. to DIN 488:2009-08 ⁴⁾	$M^0_{Rk,s}$ [Nm]	33	65	112	178	265	518	1012	-	1422	-	2123
Partial safety factors for steel failure												
Partial safety factor for rebar B500B acc. to DIN 488:2009-08 ⁵⁾	$\gamma_{Ms,v}$ ¹⁾ [-]	1,5						-	1,5	-	1,5	
Concrete pry-out failure												
Factor in equation (5.7) of Technical Report TR 029 for the design of bonded anchors	k [-]							2,0				
Partial safety factor	γ_{Mcp} ¹⁾ [-]							1,5 ²⁾				
Concrete edge failure												
See chapter 5.2.3.4 of Technical Report TR 029 for the design of bonded anchors												
Partial safety factor	γ_{Mc} ¹⁾ [-]							1,5 ²⁾				

¹⁾ In absence of national regulations

²⁾ The partial safety factor $\gamma_2 = 1,0$ is included.

³⁾ The characteristic shear resistance $V_{Rk,s}$ for rebars that do not fulfil the requirements acc. DIN 488 shall be calculated acc. Technical Report TR 029, Equation (5.5)

⁴⁾ The characteristic bending resistance $M^0_{Rk,s}$ for rebars that do not fulfil the requirements acc. DIN 488 shall be calculated acc. Technical Report TR 029, Equation (5.6b)

⁵⁾ The partial safety factor $\gamma_{Ms,v}$ for rebars that do not fulfil the requirements acc. DIN 488 shall be calculated acc. Technical Report TR 029, Equation (3.3b) or (3.3c)

Injektionssystem Hilti HIT-RE 500

Characteristic shear resistance of rebar

Anhang 18

Table 15: Displacements under tension load¹⁾ of rebar

HIT-RE 500 with rebar...		Ø8	Ø10	Ø12	Ø14	Ø16	Ø20	Ø25	Ø26	Ø28	Ø30	Ø32
Non-cracked concrete, temperature range I ²⁾ : 40°C/24°C												
Displacement	δ_{N0} [mm/(N/mm ²)]	0,02	0,02	0,03	0,03	0,04	0,05	0,06	0,07	0,07	0,08	0,08
	$\delta_{N\infty}$ [mm/(N/mm ²)]	0,04	0,05	0,06	0,07	0,08	0,11	0,14	0,14	0,15	0,17	0,18
Non-cracked concrete, temperature range II ²⁾ : 58°C/35°C												
Displacement	δ_{N0} [mm/(N/mm ²)]	0,03	0,04	0,05	0,06	0,07	0,09	0,12	0,12	0,13	0,14	0,15
	$\delta_{N\infty}$ [mm/(N/mm ²)]	0,07	0,09	0,10	0,12	0,14	0,18	0,23	0,24	0,26	0,28	0,30
Non-cracked concrete, temperature range III ²⁾ : 70°C/43°C												
Displacement	δ_{N0} [mm/(N/mm ²)]	0,07	0,09	0,10	0,12	0,14	0,18	0,23	0,24	0,26	0,28	0,30
	$\delta_{N\infty}$ [mm/(N/mm ²)]	0,09	0,12	0,15	0,17	0,20	0,26	0,33	0,34	0,37	0,40	0,43

¹⁾ Calculation of displacement under service load: τ_{Sd} design value of bond stress

Displacement under short term loading = $\delta_{N0} \times \tau_{Sd} / 1,4$

Displacement under long term loading = $\delta_{N\infty} \times \tau_{Sd} / 1,4$

²⁾ Explanation see chapter 1.2

Table 16: Displacements under shear load¹⁾ of rebar

HIT-RE 500 with rebar...		Ø8	Ø10	Ø12	Ø14	Ø16	Ø20	Ø25	Ø26	Ø28	Ø30	Ø32
Displacement	δ_{V0} [mm/kN]	0,06	0,05	0,05	0,04	0,04	0,04	0,03	0,03	0,03	0,03	0,03
	$\delta_{V\infty}$ [mm/kN]	0,09	0,08	0,07	0,06	0,05	0,05	0,05	0,05	0,04	0,04	0,04

¹⁾ Calculation of displacement under service load: V_{Sd} design value of shear load

Displacement under short term loading = $\delta_{V0} \times V_{Sd} / 1,4$

Displacement under long term loading = $\delta_{V\infty} \times V_{Sd} / 1,4$

Injektionssystem Hilti HIT-RE 500

Displacements of rebar

Anhang 19

Table 17: Characteristic tension resistance of internal threaded sleeve HIS-(R)N

HIT-RE 500 with HIS-(R)N ...			M8	M10	M12	M16	M20
Steel failure							
Char. resistance HIS-N with screw grade 8.8	$N_{Rk,s}$	[kN]	25	46	67	118	109
Partial safety factor	$\gamma_{Ms,N}^{1)}$	[-]	1,43	1,5		1,47	
Char. resistance HIS-RN with screw grade 70	$N_{Rk,s}$	[kN]	26	41	59	110	166
Partial safety factor	$\gamma_{Ms,N}^{1)}$	[-]	1,87				2,4
Combined pullout and concrete cone failure ^{4) + 7)}							
Effective anchorage depth	h_{ef}	[mm]	90	110	125	170	205
Diameter of element	d	[mm]	12,5	16,5	20,5	25,4	27,6
Characteristic bond resistance in non-cracked concrete C20/25 with Hilti hollow drill bit or hammer drilling							
Temp. range I ⁵⁾ : 40°C/24°C	$N_{Rk}^{7)}$	[kN]	40	60	95	170	200
Temp. range II ⁵⁾ : 58°C/35°C	$N_{Rk}^{7)}$	[kN]	35	50	75	140	170
Temp. range III ⁵⁾ : 70°C/43°C	$N_{Rk}^{7)}$	[kN]	20	30	40	75	95
Characteristic bond resistance in non-cracked concrete C20/25 with diamond coring							
Temp. range I ⁵⁾ : 40°C/24°C	$N_{Rk}^{7)}$	[kN]	40	60	75	115	140
Temp. range II ⁵⁾ : 58°C/35°C	$N_{Rk}^{7)}$	[kN]	35	50	60	95	115
Temp. range III ⁵⁾ : 70°C/43°C	$N_{Rk}^{7)}$	[kN]	20	30	40	60	75
Increasing factors for $N_{Rk,p}$	ψ_c	C30/37	1,04				
		C40/50	1,07				
		C50/60	1,09				
Splitting failure ^{4) + 7)}							
Edge distance $C_{cr,sp}$ [mm] for	$h / h_{ef}^{6)} \geq 2,0$		1,0 · h_{ef}				
	$2,0 > h / h_{ef}^{6)} > 1,3$		4,6 h_{ef} - 1,8 h				
	$h / h_{ef}^{6)} \leq 1,3$		2,26 h_{ef}				
Spacing	$S_{cr,sp}$	[mm]	2 x $C_{cr,sp}$				
Partial safety factors for combined pullout, concrete cone and splitting failure, holes drilled by:							
Hilti hollow drill bit:	$\gamma_{Mp} = \gamma_{Mc} = \gamma_{Msp}^{1)}$	[-]	1,8 ²⁾		2,1 ³⁾		
Hammer drilling:	$\gamma_{Mp} = \gamma_{Mc} = \gamma_{Msp}^{1)}$	[-]			2,1 ⁴⁾		
Diamond coring:	$\gamma_{Mp} = \gamma_{Mc} = \gamma_{Msp}^{1)}$	[-]	1,8 ²⁾		2,1 ³⁾		

¹⁾ In absence of other national regulations

²⁾ The partial safety factor $\gamma_2 = 1,2$ is included.

³⁾ The partial safety factor $\gamma_2 = 1,4$ is included.

⁴⁾ Calculation of concrete failure and splitting see chapter 4.2.1

⁵⁾ Explanation in section 1.2

⁶⁾ h = base material thickness; h_{ef} = anchorage depth

⁷⁾ For design according TR029, the characteristic bond resistance may be calculated from the characteristic tension load values for combined pull-out and concrete cone failure according: $\tau_{Rk} = N_{Rk} / (h_{ef} \cdot d_1 \cdot \pi)$

Injektionssystem Hilti HIT-RE 500

Characteristic tension resistance of internal threaded sleeve HIS-(R)N

Anhang 20

Table 18: Characteristic shear resistance of internal threaded sleeve HIS-(R)N

HIT-RE 500 with HIS-(R)N ...		M8	M10	M12	M16	M20
Steel failure without lever arm ³⁾						
Char. resistance HIS-N with screw grade 8.8	$V_{Rk,s}$ [kN]	13	23	39	59	55
Partial safety factor	$\gamma_{Ms,N}^{1)}$ [-]	1,25		1,5		
Char. resistance HIS-RN with screw grade 70	$V_{Rk,s}$ [kN]	13	20	30	55	83
Partial safety factor	$\gamma_{Ms,N}^{1)}$ [-]	1,56				2,0
Steel failure with lever arm						
Char. resistance HIS-N with screw grade 8.8	$M^0_{Rk,s}$ [kN]	30	60	105	266	519
Partial safety factor	$\gamma_{Ms,N}^{1)}$ [-]	1,25				
Char. resistance HIS-RN with screw grade 70	$M^0_{Rk,s}$ [kN]	26	52	92	233	454
Partial safety factor	$\gamma_{Ms,N}^{1)}$ [-]	1,56				
Concrete pry-out failure						
Factor in equation (5.7) of Technical Report TR 029 for the design of bonded anchors	k [-]	2,0				
Partial safety factor	$\gamma_{Mcp}^{1)}$ [-]	1,5 ²⁾				
Concrete edge failure						
See chapter 5.2.3.4 of Technical Report TR029 for the design of bonded anchors						
Partial safety factor	$\gamma_{Mc}^{1)}$ [-]	1,5 ²⁾				

¹⁾ In absence of national regulations

²⁾ The partial safety factor $\gamma_2 = 1,0$ is included.

³⁾ Acc. to chapter 4.2.2 commercial standard rods that fulfill the ductility requirement $A_5 > 8\%$ (see table 6) can be used only

Injektionssystem Hilti HIT-RE 500

Characteristic shear resistance of internal threaded sleeve HIS-(R)N

Anhang 21

Table 19: Displacements under tension load ¹⁾ of internal threaded sleeve HIS-(R)N

HIT-RE 500 with HIS-(R)N ...		M8	M10	M12	M16	M20
Non-cracked concrete, temperature range I ²⁾ : 40°C/24°C						
Displacement	δ_{N0} [mm/(10kN)]	0,08	0,06	0,06	0,04	0,04
	$\delta_{N\infty}$ [mm/(10kN)]	0,18	0,15	0,14	0,10	0,09
Non-cracked concrete, temperature range II ²⁾ : 58°C/35°C						
Displacement	δ_{N0} [mm/(10kN)]	0,15	0,13	0,12	0,09	0,07
	$\delta_{N\infty}$ [mm/(10kN)]	0,31	0,26	0,23	0,17	0,15
Non-cracked concrete, temperature range III ²⁾ : 70°C/43°C						
Displacement	δ_{N0} [mm/(10kN)]	0,31	0,26	0,23	0,17	0,14
	$\delta_{N\infty}$ [mm/(10kN)]	0,43	0,36	0,33	0,24	0,20

¹⁾ Calculation of displacement under service load: N_{Sd} design value of tension load

Displacement under short term loading = $\delta_{N0} * N_{Sd} / (10 * 1,4)$

Displacement under long term loading = $\delta_{N\infty} * N_{Sd} / (10 * 1,4)$

²⁾ Explanation see chapter 1.2

Table 20: Displacements under shear load ¹⁾ of internal threaded sleeve HIS-(R)N

HIT-RE 500 with HIS-(R)N ...		M8	M10	M12	M16	M20
Displacement	δ_{V0} [mm/kN]	0,06	0,06	0,05	0,04	0,04
	$\delta_{V\infty}$ [mm/kN]	0,09	0,08	0,08	0,06	0,06

¹⁾ Calculation of displacement under service load: V_{Sd} design value of shear load

Displacement under short term loading = $\delta_{V0} * V_{Sd} / 1,4$

Displacement under long term loading = $\delta_{V\infty} * V_{Sd} / 1,4$

Injektionssystem Hilti HIT-RE 500

Displacements of internal threaded sleeve HIS-(R)N

Anhang 22

Table 21: Characteristic tension resistance of tension anchor HZA-R

HIT-RE 500 with HZA-R ...	M12	M16	M20	M24	
Steel failure					
Characteristic resistance $N_{Rk,s}$ [kN]	62	111	173	248	
Partial safety factor $\gamma_{Ms}^{1)}$ [-]	1,4				
Combined pullout and concrete cone failure ⁴⁾					
Diameter of element d_1 [mm]	12	16	20	25	
Characteristic bond resistance in non-cracked concrete C20/25 with Hilti hollow drill bit or hammer drilling					
Temp. range I ⁵⁾ : 40°C/24°C $\tau_{Rk,ucr}$ [N/mm ²]	15	14	14	13	
Temp. range II ⁵⁾ : 58°C/35°C $\tau_{Rk,ucr}$ [N/mm ²]	12	11	11	11	
Temp. range III ⁵⁾ : 70°C/43°C $\tau_{Rk,ucr}$ [N/mm ²]	7	7	6,5	6,5	
Characteristic bond resistance in non-cracked concrete C20/25 with diamond coring					
Temp. range I ⁵⁾ : 40°C/24°C $\tau_{Rk,ucr}$ [N/mm ²]	12	11	10	8,5	
Temp. range II ⁵⁾ : 58°C/35°C $\tau_{Rk,ucr}$ [N/mm ²]	9,5	8,5	8	7	
Temp. range III ⁵⁾ : 70°C/43°C $\tau_{Rk,ucr}$ [N/mm ²]	6	5	4,5	4	
Increasing factors for τ_{Rk} ψ_c	C30/37	1,04			
	C40/50	1,07			
	C50/60	1,09			
Range of effective anchorage depth for calculation of $N_{Rk,p}^0$ acc. Eq. 5.2a (TR 029, 5.2.2.3 Combined pull-out and concrete cone failure)	min h_{ef} [mm]	70	80	90	100
	max h_{ef} [mm]	140	220	300	400
Concrete cone failure ⁴⁾					
Range of effective anchorage depth for calculation of $N_{Rk,c}^0$ acc. Eq. 5.3a (TR 029, 5.2.2.4 Concrete cone failure)	min h_{ef} [mm]	170	180	190	200
	max h_{ef} [mm]	240	320	400	500
Splitting failure ⁴⁾					
Edge distance $c_{cr,sp}$ [mm] for	$h / h_{ef}^{6)} \geq 2,0$	$1,0 \cdot h_{ef}$			
	$2,0 > h / h_{ef}^{6)} > 1,3$	$4,6 h_{ef} - 1,8 h$			
	$h / h_{ef}^{6)} \leq 1,3$	$2,26 h_{ef}$			
Spacing $s_{cr,sp}$ [mm]	$2 \times c_{cr,sp}$				
Partial safety factors for combined pullout, concrete cone and splitting failure, holes drilled by:					
Hilti hollow drill bit: $\gamma_{Mp} = \gamma_{Mc} = \gamma_{Msp}^{1)}$ [-]	$1,8^{2)}$	$2,1^{3)}$			
Hammer drilling: $\gamma_{Mp} = \gamma_{Mc} = \gamma_{Msp}^{1)}$ [-]	$2,1^{3)}$				
Diamond coring: $\gamma_{Mp} = \gamma_{Mc} = \gamma_{Msp}^{1)}$ [-]	$1,8^{2)}$	$2,1^{3)}$			

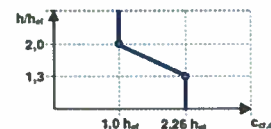

¹⁾ In absence of other national regulations

³⁾ The partial safety factor $\gamma_2 = 1,4$ is included.

⁵⁾ Explanation in section 1.2

²⁾ The partial safety factor $\gamma_2 = 1,2$ is included.

⁴⁾ Calculation of concrete failure and splitting see chapter 4.2.1

⁶⁾ h = base material thickness; h_{ef} = anchorage depth

Injektionssystem Hilti HIT-RE 500

Characteristic tension resistance of tension anchor HZA-R

Anhang 23

Table 22: Characteristic shear resistance of tension anchor HZA-R

HIT-RE 500 with HZA-R ...	M12	M16	M20	M24
Steel failure without lever arm				
Characteristic resistance $V_{Rk,s}$ [kN]	31	55	86	124
Steel failure with lever arm				
Characteristic resistance $M^0_{Rk,s}$ [Nm]	97	235	457	790
Partial safety factor for steel failure				
Partial safety factor γ_{Ms} ¹⁾ [-]	1,25			
Concrete pry-out failure				
Factor in equation (5.7) of Technical Report TR 029 for the design of bonded anchors k [-]	2,0			
Partial safety factor γ_{Mcp} ¹⁾ [-]	1,5 ²⁾			
Concrete edge failure				
See chapter 5.2.3.4 of Technical Report TR 029 for the design of bonded anchors				
Partial safety factor γ_{Mc} ¹⁾ [-]	1,5 ²⁾			

¹⁾ In absence of national regulations

²⁾ The partial safety factor $\gamma_2 = 1,0$ is included.

Injektionssystem Hilti HIT-RE 500

Characteristic shear resistance of tension anchor HZA-R

Anhang 24

Table 23: Displacements under tension load ¹⁾ of tension anchor HZA-R

HIT-RE 500 with HZA-R ...		M12	M16	M20	M24
Non-cracked concrete, temperature range I ²⁾ : 40°C/24°C					
Displacement	δ_{N0} [mm/(N/mm ²)]	0,03	0,4	0,05	0,06
	$\delta_{N\infty}$ [mm/(N/mm ²)]	0,06	0,08	0,11	0,14
Non-cracked concrete, temperature range II ²⁾ : 58°C/35°C					
Displacement	δ_{N0} [mm/(N/mm ²)]	0,05	0,07	0,09	0,12
	$\delta_{N\infty}$ [mm/(N/mm ²)]	0,10	0,14	0,18	0,23
Non-cracked concrete, temperature range III ²⁾ : 70°C/43°C					
Displacement	δ_{N0} [mm/(N/mm ²)]	0,10	0,14	0,18	0,23
	$\delta_{N\infty}$ [mm/(N/mm ²)]	0,15	0,20	0,26	0,33

¹⁾ Calculation of displacement under service load: τ_{sd} design value of bond stress

Displacement under short term loading = $\delta_{N0} \times \tau_{sd} / 1,4$

Displacement under long term loading = $\delta_{N\infty} \times \tau_{sd} / 1,4$

²⁾ Explanation see chapter 1.2

Table 24: Displacements under shear load ¹⁾ of tension anchor HZA-R

HIT-RE 500 with HZA-R ...		M12	M16	M20	M24
Displacement	δ_{V0} [mm/kN]	0,05	0,04	0,04	0,03
	$\delta_{V\infty}$ [mm/kN]	0,08	0,06	0,06	0,05

¹⁾ Calculation of displacement under service load: V_{sd} design value of shear load

Displacement under short term loading = $\delta_{V0} \times V_{sd} / 1,4$

Displacement under long term loading = $\delta_{V\infty} \times V_{sd} / 1,4$

Injektionssystem Hilti HIT-RE 500

Displacements of tension anchor HZA-R

Anhang 25