

ES

DECLARACIÓN DE PRESTACIONES

de conformidad con el Anexo III de la Regulación (UE) N.º 305/2011 (Reglamento Europeo de Productos de Construcción)

Abrazadera intumescente infinita Hilti CFS-C EL

N.º **Hilti CFS "0843-CPR-0154"**

1. Código de identificación único del tipo de producto:

Abrazadera intumescente infinita Hilti CFS-CEL

2. Usos previstos:

Producto intumescente y de sellado para sellados de penetración, véase ETA - 14/0085 (28.12.2015)

Paso de tuberías	Tuberías de plástico	El campo de aplicación debe ajustarse al contenido de la ETA - 14/0085 correspondiente
	Tuberías acústicas	
	Aplicaciones de tuberías de plástico en atravesamientos mixtos específicos definidos en las ETA correspondientes	

3. Fabricante:

HILTI Corporation, Feldkircherstrasse 100, 9494 Schaan, Principado de Liechtenstein

4. Sistemas de evaluación y verificación de la constancia de las prestaciones (EVCP):

Sistema 1

5. Documento de evaluación europeo:

ETAG n.º 026-2

Evaluación técnica europea:

ETA - 14/0085 (28.12.2015)

Organismo de Evaluación Técnica:

OIB Austrian Institute of Construction Engineering (Instituto Austriaco de Ingeniería Civil)

Organismos notificados:

UL International (UK) Ltd, N.º 0843

6. Prestaciones declaradas:

Características básicas	Prestaciones declaradas/especificación técnica armonizada
Reacción en caso de incendio	Clase E conforme a EN 13501-1
Resistencia en caso de incendio	Prestaciones de resistencia al fuego y campo de aplicación de conformidad con EN 13501-2. Consulte el Anexo
Permeabilidad al aire	Probada según EN 1026. Consulte el Anexo
Permeabilidad al agua	Probada según ETAG 026-2. Consulte el Anexo
Sustancias peligrosas	Consulte el Anexo
Protección acústica	Probada según EN ISO 140-3, EN ISO 717-1 y EN ISO 10140-10. Ver Anexo
Durabilidad y operatividad	Y2, de conformidad con ETAG 026-2, Informe técnico EOTA - TR024
Otros	No aplicable/ningún rendimiento determinado

Las prestaciones del producto identificado anteriormente son conformes con el conjunto de prestaciones declaradas.

La presente declaración de prestaciones se emite, de conformidad con el Reglamento (UE) n.º 305/2011, bajo la responsabilidad del fabricante arriba identificado.

Firmado en nombre del fabricante por:

Jingyan Zhou
Product Manager
Business Unit Fire Protection
Hilti Corporation

Martin Althof
Head of Quality
Business Unit Fire Protection
Hilti Corporation

Schaan, 22nd March 2018

DoP_es_03-01_00000001667_Hilti CFS-C_EL_"0843-CPR-0154"

ANNEX

3.1.1 Reaction to fire

The components of "Hilti Firestop Collar Endless CFS-C EL" were assessed according to ETAG 026-Part 2 clause 2.4.1 and classified according to EN 13501-1.

The reaction to fire classification for the inlay of "Hilti Firestop Collar Endless CFS-C EL" is class "E" according to EN 13501-1. (Other components are made of stainless steel with reaction to fire class "A1" according to Commission Decision 96/603/EC1).

The reaction to fire classification for "Hilti Firestop Acrylic Sealant CFS-S ACR" is class "D-s1 d0" according to EN 13501-1.

The reaction to fire classification for "Hilti Firestop Mastic Filler CFS-FIL" is class "E" according to EN 13501-1.

The reaction to fire classification for "Hilti Fire Stop Coating CFS-CT" is class "D-s2 d0" according to EN 13501-1.

3.1.2 Resistance to fire

The resistance to fire classification according to EN 13501-2 of penetration seals made of "Hilti Firestop Collar Endless CFS-C EL" is given in Annex 3 of the ETA.

Information on ancillary products, which were tested within the framework of this European Technical Assessment for assessing resistance to fire is given in Annex 2 of the ETA.

3.2.1 Air permeability

Air tightness for a single penetration of a plastic pipe, equipped with "Hilti Firestop Collar Endless CFS-C EL" can only be achieved when the annular gap is sealed with a sealant, e.g. "Hilti Firestop Acrylic Sealant CFS-S ACR" or "Hilti Firestop Mastic Filler CFS-FIL".

For "Hilti Firestop Acrylic Sealant CFS-S ACR" and "Hilti Firestop Mastic Filler CFS-FIL" the gas permeability regarding the gases air, nitrogen (N₂), carbon dioxide (CO₂) and CH₄ (methane) has been tested according to the principles of EN 1026.

The "Hilti Firestop Acrylic Sealant CFS-S ACR" was installed in a thickness of 10 mm.

The "Hilti Firestop Mastic Filler CFS-FIL" was installed in a thickness of 50 mm.

The "Hilti Firestop Coating CFS-CT" was tested on a precoated board "Hilti Firestop Board CFS-CT B 1S". Two precoated board samples (each of 50 mm mineral wool coated with a dry film thickness of 1 to 2 mm) were put together and gas flow was determined.

The non-tested air flow rate for "Hilti Firestop Mastic Filler CFS-FIL" and "Hilti Firestop Coating CFS-CT" will be similar to the nitrogen flow rate, as air consists of nearly 80 % of tested nitrogen.

For annular gaps sealed with cementitious mortar or gypsum plaster no performance has been determined.

¹ Official Journal of the European Communities no. L 267, 19.10.1996, p. 23

The following flow rates per area (q/A) have been achieved for the given air pressure differences (Δp). The flow rate index indicates the type of gas:

Gas permeability of “Hilti Firestop Acrylic Sealant CFS-S ACR”, “Hilti Firestop Mastic Filler CFS-FIL”, “Hilti Firestop Coating CFS-CT”, “Hilti Firestop Board CFS-CT B 1S” and “Hilti Firestop Board CFS-CT B 2S”

Product	Δp [Pa]	q/A air [m ³ /(h·m ²)]	q/A N ₂ [m ³ /(h·m ²)]	q/A CO ₂ [m ³ /(h·m ²)]	q/A CH ₄ [m ³ /(h·m ²)]
CFS-S ACR	50	≤ 1,9E-06	≤ 1,1E-06	≤ 6,4E-05	≤ 4,3E-05
	250	≤ 9,7E-06	≤ 5,5E-06	≤ 3,2E-04	≤ 2,1E-04
CFS-FIL	50	Not tested	< 1 E-06	< 1 E-06	< 1 E-06
	250	Not tested	< 1 E-06	< 1 E-06	< 1 E-06
CFS-CT / CFS-CT B 1S/2S	50	Not tested	≤ 3,2 E-02	≤ 6,0 E-02	≤ 6,5 E-02
	250	Not tested	≤ 1,6 E-01	≤ 3,0 E-01	≤ 3,3 E-01

The declared values refer to a body of pure “Hilti Firestop Acrylic Sealant CFS-S ACR”, “Hilti Firestop Mastic Filler CFS-FIL”, “Hilti Firestop Coating CFS-CT” / “Hilti Firestop Board CFS-CT B 1S” / “Hilti Firestop Board CFS-CT B 2S” without any penetrating installation.

3.2.2 Water permeability

Water tightness for a single penetration of a plastic pipe, equipped with “Hilti Firestop Collar Endless CFS-C EL” can only be achieved when the annular gap is sealed with a sealant, e.g. “Hilti Firestop Acrylic Sealant CFS-S ACR”, “Hilti Firestop Mastic CFS-FIL” or “Hilti Firestop Coating CFS-CT” / “Hilti Firestop Board CFS-CT B 1S” / “Hilti Firestop Board CFS-CT B 2S”.

The water permeability of “Hilti Firestop Acrylic Sealant CFS-S ACR”, “Hilti Firestop Mastic Filler CFS-FIL”, “Hilti Firestop Coating CFS-CT” / “Hilti Firestop Board CFS-CT B 1S” / “Hilti Firestop Board CFS-CT B 2S” has been tested according to the principles given in Annex C of ETAG 026-Part 2. The specimen consisted of 2 mm “Hilti Firestop Acrylic Sealant CFS-S ACR” and “Hilti Firestop Mastic Filler CFS-FIL” (dry film thickness) on mineral wool. “Hilti Firestop Coating CFS-CT” was tested as a 0,7mm thick coating dry film on mineral wool board.

Test result: Water tight to 1000 mm head of water or 9806 Pa.

For annular gaps sealed with cementitious mortar or gypsum plaster no performance has been determined.

3.2.3 Release of dangerous substances

According to the manufacturer’s declaration “Hilti Firestop Collar Endless CFS-C EL” does not contain dangerous substances detailed in Council Directive 67/548/EEC and Regulation (EC) no 1272/2008 as well as EOTA TR 034 (General ER 3 Checklist for ETAGs/CUAPs/ETAs- Content and/or release of dangerous substances in products/kits), edition March 2012.

A written declaration in this respect was submitted by the ETA-holder.

In addition to the specific clauses relating to dangerous substances contained in this European Technical Assessment, there may be other requirements applicable to the products falling within its scope (e.g. transposed European legislation and national laws, regulations and administrative provisions). In order to meet the provisions of the Construction Product Regulation, these requirements need also to be complied with, when and where they apply.

3.4 Protection against noise (BWR 5)

3.4.1 Airborne sound insulation

Airborne sound insulation for a single penetration of a plastic pipe, equipped with “Hilti Firestop Collar Endless CFS-C EL” can only be achieved when the annular gap is sealed “Hilti Firestop Acrylic Sealant CFS-S ACR”. It has to be noted that the values given in in this clause are only valid if the annular gap is sealed using stone wool as backfilling material (which is not necessary in all cases for fire resistance – see Annex 3 of the ETA).

Test reports from noise reduction according to EN ISO 140-10, EN ISO 10140-1, EN ISO 10140-2 and EN ISO 717-1 have been provided.

The acoustic tests were performed in a flexible wall. “Hilti Firestop Acrylic Sealant CFS-S ACR” was tested as seal around a plastic pipes, filled with an acoustic sealant to simulate closed pipes. The seal was 30 mm wide (annular gap) and 25 mm deep on both sides. The flexible wall consisted of a 2 x 12,5 mm gypsum board on both sides, inside isolated with 2 x 50 mm mineral wool boards and a 5 mm air gap in between. It was tested a 32 mm x 1,8 mm PP pipe in a diameter 60 mm hole (scenario 1) and a 90 mm x 10 mm PVC-U pipe in a 120 mm hole (scenario 2). A PE sound decoupling hose was covered over the pipe, penetrating wall and collars “Hilti Firestop Collar Endless CFS-C EL”. The area of tested scenario 1 was 0,00258 m², the area of tested scenario 2 was 0,0063 m².

The acoustic characteristics of the walls itself have not been measured. According to these tests reports the single number ratings are:

Flexible wall:

Weighted element-normalized level difference:

$D_{n,e,w}(C, C_{tr}) = 68 (-2; -6)$ dB (scenario 1) and $D_{n,e,w}(C, C_{tr}) = 64 (-3; -)$ dB (scenario 2)

From this $D_{n,e,w}$ the weighted sound reduction index calculates to:

$R_w(C; C_{tr}) = 61 (-3; -6)$ dB (scenario 1) and $R_w R(C; C_{tr}) = 56 (-2; -2)$ dB (scenario 2).

It should be noticed that both above mentioned results apply to the total wall construction of the size $S = 1,25 \text{ m} \times 1,50 \text{ m} (= 1,88 \text{ m}^2)$.

$D_{n,e,w}$: weighted element-normalized level difference of small building elements (given with spectrum adaptation terms C and C_{tr})

R_w : weighted sound reduction index (given with spectrum adaptation terms C and C_{tr})

ANNEX 2

DESCRIPTION OF PRODUCT(S) & PRODUCT LITERATURE

2.1. Product

Hilti Firestop Collar Endless CFS-C EL

The inlay of the collar consists of one intumescent strip with a soft polyurethane foam layer as a noise decoupling element. A detailed specification of the product is contained in document "Identification / Product Specification" relating to this European Technical Assessment, which is a non-public part of this ETA.

The Control Plan is defined in document "Control Plan" relating to this European Technical Assessment, which is a non-public part of this ETA.

Technical product literature

- Technical Data Sheet Hilti Firestop Collar Endless CFS-C EL (including the use of ancillary products according to Annex 2 of the ETA).

2.2. Ancillary products

Hilti Firestop Acrylic Sealant CFS-S ACR

A detailed specification of the product is contained in document "Identification / Product Specification relating to ETA-10/0292 and ETA-10/0389 - Hilti Firestop Acrylic Sealant CFS-S ACR", which is a non-public part of the referenced ETAs.

The Control Plan is defined in document "Control Plan relating to ETA-10/0292 and ETA-10/0389 - Hilti Firestop Acrylic Sealant CFS-S ACR" which is a non-public part of the referenced ETAs.

Hilti Firestop Acrylic Sealant CFS-S ACR is available in three several colours (white, grey, red) and in several packaging (cartridges, foil bags and pails).

Gypsum plaster

Any gypsum plaster suitable for use with flexible wall constructions or the intended type of rigid walls or floors may be used.

Cementious mortar

Any cementious mortar according EN 998-2 - class M10 - is suitable for use with the intended type of rigid walls or floors may be used.

Mineral wool

Loose mineral wool products suitable for being used as backfilling material of Hilti Firestop Acrylic Sealant CFS-S ACR

Product	Manufacturer	Specification
Heralan LS	Knauf Insulation GmbH	Product data sheet of Knauf

Isover loose wool SL	Saint-Gobain ISOVER	Product data sheet of Isover
Isover Universal-Stopfwole	Saint-Gobain ISOVER	Product data sheet of Isover
Rockwool RL	Rockwool	Product data sheet of Rockwool
Paroc Pro Loose Wool	Paroc OY AB	Product data sheet of Paroc

- Combustibility class: A1 or A2 in accordance with EN 13501-1

Hilti Firestop Mastic Filler CFS-FIL

The filler is available as a cartridge or as a foil packs.

The Control Plan is defined in document “Control Plan” relating to the European Technical Assessment ETA-13/0099 – Hilti Firestop Mastic Filler CFS-FIL”, which is a non-public part of this ETA.

Suitable dispensers:

- Hilti CFS-DISP / CS 201-P1 (for cartridge)
- Hilti CS 270-P1 (for foil pack)

Hilti Fire Stop Coating CFS-CT

A detailed specification of the product is contained in document “Identification / Product Specification” relating to the European Technical Assessment ETA-11/0429 - Hilti Fire Stop Coating CFS-CT which is a non-public part of the referenced ETAs. Within this ETA a detailed description of the coated fire stop board Hilti CFS-CT B – the applied and dried coating CFS-CT on mineral wool boards. There is a one side coated version (CFS-CT B 1S) and a double side coated version (CFS-CT B 2S) available.

The Control Plan is defined in document "Control Plan" relating to the European Technical Assessment ETA-11/0429 - Hilti Fire Stop Coating CFS-CT" which is a non-public part of the referenced ETAs.

ANNEX 3

RESISTANCE TO FIRE CLASSIFICATION OF PENETRATION SEALS MADE OF HILTI FIRESTOP COLLAR CFS-C EL

Intended use of pipes and reference to relevant section

(list not exhaustive, other use of pipes possible)

Pipe Material:

PE

Manufacturer, Product / Pipe Standard:

EN 1519-1, EN12666-1, EN 12201-2

Application	Shaftwall	Flexible and rigid wall $tE \geq 100 \text{ mm}$ $\rho E \geq 650 \text{ kg/m}^3$ (for rigid wall only)	Rigid wall $tE \geq 100 \text{ mm}$ $\rho E \geq 650 \text{ kg/m}^3$	Rigid wall $tE \geq 150 \text{ mm}$ $\rho E \geq 650 \text{ kg/m}^3$	Rigid floor $tE \geq 150 \text{ mm}$ $\rho E \geq 650 \text{ kg/m}^3$
Waste water	3.5.2.1	3.2.2.1, 3.2.2.21 (inclined 45°) 3.2.2.22 (collar to Mineral Wool) 3.2.2.23 (collar to CFS-B) 3.2.2.24 (collar to board) 3.2.2.25 (collar to collar)	3.2.2.1, 3.2.2.21 (inclined 45°) 3.2.2.22 (collar to Mineral Wool) 3.2.2.23 (collar to CFS-B) 3.2.2.24 (collar to board) 3.2.2.25 (collar to collar) 3.3.2.1 3.3.2.9 (pipe on the wall) 3.3.2.12 (roof drainage) 3.3.2.14 (use of oddment) 3.3.2.15 (hooks in mortar) 3.3.2.19 (pipes in corner)	3.2.2.1, 3.2.2.21 (inclined 45°) 3.2.2.22 (collar to Mineral Wool) 3.2.2.23 (collar to CFS-B) 3.2.2.24 (collar to board) 3.2.2.25 (collar to collar) 3.3.2.1 3.3.2.9 (pipe on the wall) 3.3.2.12 (roof drainage) 3.3.2.14 (use of oddment) 3.3.2.15 (hooks in mortar) 3.3.2.19 (pipes in corner) 3.3.2.20 3.3.2.32 (collar to collar)	3.4.2.1 3.4.2.14 3.4.2.30 (use of oddment) 3.4.2.31 (hooks in wet mortar) 3.4.2.32 (inclined pipes 45°) 3.4.2.35 (pipes in corner) 3.4.2.36 (pipe on the wall) 3.4.2.38 (collar to collar) 3.4.2.39 (collar to collar) 3.4.2.40 (collar to Mineral Wool) 3.4.2.41 (collar to CFS-B) 3.4.2.42 (collar to board) 3.4.2.43 roof drainage 3.4.2.44 (pipe junction / manifold)

Pipe Material:

PE

Manufacturer, Product / Pipe Standard:

Geberit Silent dB 20 (non regulated by EN standards)

Application	Shaftwall	Flexible and rigid wall $t_E \geq 100 \text{ mm}$ $\rho_E \geq 650 \text{ kg/m}^3$ (for rigid wall only)	Rigid wall $t_E \geq 100 \text{ mm}$ $\rho_E \geq 650 \text{ kg/m}^3$	Rigid wall $t_E \geq 150 \text{ mm}$ $\rho_E \geq 650 \text{ kg/m}^3$	Rigid floor $t_E \geq 150 \text{ mm}$ $\rho_E \geq 650 \text{ kg/m}^3$
Waste water	3.5.2.6	3.2.2.12, 3.2.2.21(inclined 45°) 3.2.2.22 (collar to Mineral Wool) 3.2.2.23 (collar to CFS-B) 3.2.2.24 (collar to board) 3.2.2.25 (collar to collar)	3.2.2.12, 3.2.2.21 (inclined 45°) 3.2.2.22 (collar to Mineral Wool) 3.2.2.23 (collar to CFS-B) 3.2.2.24 (collar to board) 3.2.2.25 (collar to collar) 3.3.2.9 (pipe on the wall) 3.3.2.12 (roof drainage) 3.3.2.13A (2x45° elbow) 3.3.2.13B (pipe coupling) 3.3.2.14(use of oddment) 3.3.2.15 (hooks in mortar) 3.3.2.19 (pipes in corner)	3.2.2.12, 3.2.2.21 (inclined 45°) 3.2.2.22 (collar to Mineral Wool) 3.2.2.23 (collar to CFS-B) 3.2.2.24(collar to board) 3.2.2.25 (collar to collar) 3.3.2.9 (pipe on the wall) 3.3.2.12 (roof drainage) 3.3.2.13A (pipe coupling) 3.3.2.13B (2x45° elbow) 3.3.2.14 (use of oddment) 3.3.2.15 (hooks in mortar) 3.3.2.19 (pipes in corner) 3.3.2.30 3.3.2.32 (collar to collar)	3.4.2.10 3.4.2.13A (2 x 45° elbow) 3.4.2.13B (pipe coupling) 3.4.2.24 3.4.2.30 (use of oddment) 3.4.2.31 (hooks in wet mortar) 3.4.2.32 (inclined pipes 45°) 3.4.2.35 (pipes in corner) 3.4.2.36 (pipe on the wall) 3.4.2.38 (collar to collar) 3.4.2.39 (collar to collar) 3.4.2.40 (collar to Mineral Wool) 3.4.2.41 (collar to CFS-B) 3.4.2.42 (collar to board) 3.4.2.43 roof drainage 3.4.2.44 (pipe junction / manifold)

Pipe Material:

PE

Manufacturer, Product / Pipe Standard:

Wavin W (EN15494 and EN 12201-2, DIN 8074/75)

Application	Shaftwall	Flexible and rigid wall $t_E \geq 100 \text{ mm}$ $\rho_E \geq 650 \text{ kg/m}^3$ (for rigid wall only)	Rigid wall $t_E \geq 100 \text{ mm}$ $\rho_E \geq 650 \text{ kg/m}^3$	Rigid wall $t_E \geq 150 \text{ mm}$ $\rho_E \geq 650 \text{ kg/m}^3$	Rigid floor $t_E \geq 150 \text{ mm}$ $\rho_E \geq 650 \text{ kg/m}^3$
Industrial	3.5.2.2	3.2.2.4, 3.2.2.5, 3.2.2.6, 3.2.2.7 3.2.2.21 (inclined 45°) 3.2.2.22 (collar to Mineral Wool) 3.2.2.23 (collar to CFS-B) 3.2.2.24 (collar to board) 3.2.2.25 (collar to collar)	3.2.2.4, 3.2.2.5, 3.2.2.6, 3.2.2.7 3.2.2.21 (inclined 45°) 3.2.2.22 (collar to Mineral Wool) 3.2.2.23 (collar to CFS-B) 3.2.2.24 (collar to board) 3.2.2.25 (collar to collar) 3.3.2.2, 3.3.2.3 3.3.2.9 (pipe on the wall) 3.3.2.14 (use of oddment) 3.3.2.15 (hooks in mortar) 3.3.2.16 3.3.2.19 (pipes in corner)	3.2.2.4, 3.2.2.5, 3.2.2.6, 3.2.2.7, 3.2.2.21 (inclined 45°) 3.2.2.22 (collar to Mineral Wool) 3.2.2.23 (collar to CFS-B) 3.2.2.24 (collar to board) 3.2.2.25 (collar to collar) 3.3.2.2, 3.3.2.3, 3.3.2.9 (pipe on the wall) 3.3.2.14 (use of oddment) 3.3.2.15 (hooks in mortar) 3.3.2.15 3.3.2.19 (pipes in corner) 3.3.2.23 3.3.2.32 (collar to collar)	3.4.2.3 3.4.2.17 3.4.2.18 3.4.2.19 3.4.2.30 (use of oddment) 3.4.2.31 (hooks in wet mortar) 3.4.2.32 (inclined pipes 45°) 3.4.2.35 (pipes in corner) 3.4.2.36 (pipe on the wall) 3.4.2.38 (collar to collar) 3.4.2.39 (collar to collar) 3.4.2.40 (collar to Mineral Wool) 3.4.2.41 (collar to CFS-B) 3.4.2.42 (collar to board) 3.4.2.44 (pipe junction / manifold)

Pipe Material:

PP

Manufacturer, Product / Pipe Standard:

EN 1451-1 and DIN 8077/78

Application	Shaftwall	Flexible and rigid wall $t_E \geq 100 \text{ mm}$ $\rho_E \geq 650 \text{ kg/m}^3$ (for rigid wall only)	Rigid wall $t_E \geq 100 \text{ mm}$ $\rho_E \geq 650 \text{ kg/m}^3$	Rigid wall $t_E \geq 150 \text{ mm}$ $\rho_E \geq 650 \text{ kg/m}^3$	Rigid floor $t_E \geq 150 \text{ mm}$ $\rho_E \geq 650 \text{ kg/m}^3$
Waste water	3.5.2.5	3.2.2.10, 3.2.2.11, 3.2.2.21 (inclined 45°) 3.2.2.22 (collar to Mineral Wool) 3.2.2.23 (collar to CFS-B) 3.2.2.24 (collar to board) 3.2.2.25 (collar to collar) 3.2.2.26 (pipe coupling) 3.2.2.28 (Elbow 87°)	3.2.2.10, 3.2.2.11, 3.2.2.21 (inclined 45°) 3.2.2.22 (collar to Mineral Wool) 3.2.2.23 (collar to CFS-B) 3.2.2.24 (collar to board) 3.2.2.25 (collar to collar) 3.2.2.26 (pipe coupling) 3.2.2.28 (Elbow 87°) 3.3.2.6 3.3.2.7 3.3.2.9 (pipe on the wall) 3.3.2.14 (use of oddment) 3.3.2.15 (hooks in mortar) 3.3.2.19 (pipes in corner)	3.2.2.10, 3.2.2.11, 3.3.2.9 (pipe on the wall) 3.2.2.21 (inclined 45°) 3.2.2.22 (collar to Mineral Wool) 3.2.2.23 (collar to CFS-B) 3.2.2.24 (collar to board) 3.2.2.25 (collar to collar) 3.2.2.26 pipe coupling 3.2.2.28 Ellbow 87° 3.3.2.14 (use of oddment) 3.3.2.15 (hooks in mortar) 3.3.2.19 (pipes in corner) 3.3.2.26 3.3.2.27 3.3.2.28 3.3.2.32 (collar to collar) 3.3.2.33 (pipe coupling)	3.4.2.7 3.4.2.8 3.4.2.9 3.4.2.22 3.4.2.30 (use of oddment) 3.4.2.31 (hooks in wet mortar) 3.4.2.32 (inclined pipes 45°) 3.4.2.35 (pipes in corner) 3.4.2.36 (pipe on the wall) 3.4.2.38 (collar to collar) 3.4.2.39 (collar to collar) 3.4.2.40 (collar to Mineral Wool) 3.4.2.41 (collar to CFS-B) 3.4.2.42 (collar to board) 3.4.2.44 (pipe junction / manifold) 3.4.2.45 (pipe coupling) 3.4.2.46 (Elbow 87°)

Pipe Material:

PVC, non-regulated

Manufacturer, Product / Pipe Standard:

Friatec Friaphon

Application	Shaftwall	Flexible and rigid wall $t_E \geq 100$ mm $\rho_E \geq 650$ kg/m ³ (for rigid wall only)	Rigid wall $t_E \geq 100$ mm $\rho_E \geq 650$ kg/m ³	Rigid wall $t_E \geq 150$ mm $\rho_E \geq 650$ kg/m ³	Rigid floor $t_E \geq 150$ mm $\rho_E \geq 650$ kg/m ³
Waste water		3.2.2.13	3.2.2.13,	3.2.2.13 3.3.2.31	3.4.2.11 3.4.2.26 3.4.2.30(use of oddment) 3.4.2.31 (hooks in wet mortar) 3.4.2.32 (inclined pipes 45°) 3.4.2.35 (pipes in corner) 3.4.2.36 (pipe on the wall) 3.4.2.38 (collar to collar) 3.4.2.40 (collar to Mineral Wool) 3.4.2.41 (collar to CFS-B) 3.4.2.42 (collar to board) 3.4.2.44 (pipe junction / manifold)

Pipe Material:

PP

Manufacturer, Product / Pipe Standard:

Coes Blue Power, Coes PhoNo Fire, Geberit Silent PP, Marley Silent, Ostendorf Skolan db, Pipelife Master 3,

Poloplast Polokal NG, Poloplast Polokal 3S, Poloplast Polokal XS, Rehau Raupiano Plus, Ke Kelit PhonEx AS, Valsir Triplus,

Valsir Silere, Wavin SiTech, Wavin AS or equal products

(non regulated by EN standards)

Application	Shaftwall	Flexible and rigid wall $t_E \geq 100 \text{ mm}$ $\rho_E \geq 650 \text{ kg/m}^3$ (for rigid wall only)	Rigid wall $t_E \geq 100 \text{ mm}$ $\rho_E \geq 650 \text{ kg/m}^3$	Rigid wall $t_E \geq 150 \text{ mm}$ $\rho_E \geq 650 \text{ kg/m}^3$	Rigid floor $t_E \geq 150 \text{ mm}$ $\rho_E \geq 650 \text{ kg/m}^3$
Waste water	3.5.2.4	3.2.2.9, 3.2.2.17 and 3.2.2.19 (pipe coupling), 3.2.2.18 (87° elbow), 3.2.2.20 (2x45° elbow) 3.2.2.21 (inclined 45°) 3.2.2.22 (collar to Mineral Wool) 3.2.2.23 (collar to CFS-B) 3.2.2.24 (collar to board) 3.2.2.25(collar to collar)	3.2.2.9, 3.2.2.17 and 3.2.2.19 (pipe coupling), 3.2.2.18 (87° elbow), 3.2.2.20 (2x45° elbow) 3.2.2.21 (inclined 45°) 3.2.2.22 (collar to Mineral Wool) 3.2.2.23 (collar to CFS-B) 3.2.2.24 (collar to board) 3.2.2.25 (collar to collar) 3.3.2.5 3.3.2.9 (pipe on the wall) 3.3.2.12 roof drainage 3.3.2.14 (use of oddment) 3.3.2.15 (hooks in mortar) 3.3.2.17 (87° elbow), 3.3.2.18 (2x45° elbow) 3.3.2.19 (pipes in corner)	3.2.2.9, 3.2.2.17 and 3.2.2.19 (pipe coupling), 3.2.2.18 (87° elbow), 3.2.2.20 (2x45° elbow) 3.2.2.21 (inclined 45°) 3.2.2.22 (collar to Mineral Wool) 3.2.2.23 (collar to CFS-B) 3.2.2.24 (collar to board) 3.2.2.25 (collar to collar) 3.3.2.5 3.3.2.9 (pipe on the wall) 3.3.2.12 roof drainage 3.3.2.14 (use of oddment) 3.3.2.15(hooks in mortar) 3.3.2.17 (87° elbow), 3.3.2.18 (2x45° elbow) 3.3.2.19 (pipes in corner) 3.3.2.25 3.3.2.32 (collar to collar)	3.4.2.6 3.4.2.21 3.4.2.30 (use of oddment) 3.4.2.31 (hooks in wet mortar) 3.4.2.32 (inclined pipes 45°) 3.4.2.33 (87° elbow pipes) 3.4.2.34(2x45° elbow pipes) 3.4.2.35 (pipes in corner) 3.4.2.36 (pipe on the wall) 3.4.2.37 (pipe coupling), 3.4.2.38 (collar to collar) 3.4.2.39 (collar to collar) 3.4.2.40 (collar to Mineral Wool) 3.4.2.41 (collar to CFS-B) 3.4.2.42 (collar to board) 3.4.2.43 roof drainage 3.4.2.44 (pipe junction / manifold)

Pipe Material:

ABS and SAN+PVC pipes

Manufacturer, Product / Pipe Standard:

EN 1455-1 and EN 15493, EN 1565-1

Application	Shaftwall	Flexible and rigid wall $t_E \geq 100$ mm $\rho_E \geq 650$ kg/m ³ (for rigid wall only)	Rigid wall $t_E \geq 100$ mm $\rho_E \geq 650$ kg/m ³	Rigid wall $t_E \geq 150$ mm $\rho_E \geq 650$ kg/m ³	Rigid floor $t_E \geq 150$ mm $\rho_E \geq 650$ kg/m ³
Various	3.5.2.7	3.2.2.2, 3.2.2.3, 3.2.2.21 (inclined 45°) 3.2.2.22 (collar to Mineral Wool) 3.2.2.23 (collar to CFS-B) 3.2.2.24 (collar to board) 3.2.2.25 (collar to collar)	3.2.2.2 3.2.2.3, 3.2.2.21 (inclined 45°) 3.2.2.22 (collar to Mineral Wool) 3.2.2.23 (collar to CFS-B) 3.2.2.24 (collar to board) 3.2.2.25 (collar to collar) 3.3.2.9 (pipe on the wall) 3.3.2.14 (use of oddment) 3.3.2.15 (hooks in mortar) 3.3.2.19 (pipes in corner)	3.2.2.2 3.2.2.3, 3.2.2.21 (inclined 45°) 3.2.2.22 (collar to Mineral Wool) 3.2.2.23 (collar to CFS-B) 3.2.2.24 (collar to board) 3.2.2.25 (collar to collar) 3.3.2.9 (pipe on the wall) 3.3.2.14 (use of oddment) 3.3.2.15 (hooks in mortar) 3.3.2.19 (pipes in corner) 3.3.2.21 3.3.2.22 3.3.2.32 (collar to collar)	3.4.2.2 3.4.2.15 3.4.2.16 3.4.2.30 (use of oddment) 3.4.2.31 (hooks in wet mortar) 3.4.2.32 (inclined pipes 45°) 3.4.2.35 (pipes in corner) 3.4.2.36 (pipe on the wall) 3.4.2.38 (collar to collar) 3.4.2.39 (collar to collar) 3.4.2.40 (collar to Mineral Wool) 3.4.2.41 (collar to CFS-B) 3.4.2.42 (collar to board) 3.4.2.44 (pipe junction / manifold)

Pipe Material:

PVC-U

Manufacturer, Product / Pipe Standard:

DIN 6660

Application	Shaftwall	Flexible and rigid wall $t_E \geq 100$ mm $\rho_E \geq 650$ kg/m ³ (for rigid wall only)	Rigid wall $t_E \geq 100$ mm $\rho_E \geq 650$ kg/m ³	Rigid wall $t_E \geq 150$ mm $\rho_E \geq 650$ kg/m ³	Rigid floor $t_E \geq 150$ mm $\rho_E \geq 650$ kg/m ³
Pneumatic dispatch systems		3.2.2.14	3.2.2.14 3.3.2.8	3.2.2.14 3.3.2.29	3.4.2.12 3.4.2.23

Pipe Material: PE (1), (2), PP (3)

Manufacturer, Product / Pipe Standard: (1): EN 1519-1, EN12666-1, EN 12201-2

(2): non-regulated; Geberit Silent dB 20

(3): non-regulated; see 3.1.15

Application	Shaftwall	Flexible and rigid wall $t_E \geq 100$ mm $\rho_E \geq 650$ kg/m ³ (for rigid wall only)	Rigid wall $t_E \geq 100$ mm $\rho_E \geq 650$ kg/m ³	Rigid wall $t_E \geq 150$ mm $\rho_E \geq 650$ kg/m ³	Rigid floor $t_E \geq 150$ mm $\rho_E \geq 650$ kg/m ³
Roof drainage		Not relevant	3.3.2.12 (A–D)	3.3.2.12 (A–D)	3.4.2.43 (A–D)

Pipe Material: PP-R

Manufacturer, Product / Pipe Standard: EN 15874 (Aquatherm fusiolen=aquatherm green pipe S)

Application	Shaftwall	Flexible and rigid wall $t_E \geq 100$ mm $\rho_E \geq 650$ kg/m ³ (for rigid wall only)	Rigid wall $t_E \geq 100$ mm $\rho_E \geq 650$ kg/m ³	Rigid wall $t_E \geq 150$ mm $\rho_E \geq 650$ kg/m ³	Rigid floor $t_E \geq 150$ mm $\rho_E \geq 650$ kg/m ³
heating, sprinkler, fresh water		3.2.2.16	3.2.2.16 3.3.2.10 (multiple pipe) 3.3.2.11 (heating)	3.2.2.16 3.3.2.10 (multiple pipe) 3.3.2.11 (heating)	3.4.2.28 3.4.2.29 (multiple pipe)

Pipe Material: PE-X

Manufacturer, Product / Pipe Standard: EN 15875 (Rehau Rautitan flex)

Application	Shaftwall	Flexible and rigid wall $t_E \geq 100$ mm $\rho_E \geq 650$ kg/m ³ (for rigid wall only)	Rigid wall $t_E \geq 100$ mm $\rho_E \geq 650$ kg/m ³	Rigid wall $t_E \geq 150$ mm $\rho_E \geq 650$ kg/m ³	Rigid floor $t_E \geq 150$ mm $\rho_E \geq 650$ kg/m ³
heating, sprinkler, fresh water		3.2.2.15	3.2.2.15 3.3.2.10 (multiple pipe) 3.3.2.11 (heating)	3.2.2.15 3.3.2.10 (multiple pipe) 3.3.2.11 (heating)	3.4.2.27 3.4.2.29 (multiple pipe)

Pipe Material:

PVC

Manufacturer, Product / Pipe Standard:

EN 1452-1, EN 1329-1, EN 1453-1, EN 1566-1; DIN 8061/62, EN ISO 15493

Application	Shaftwall	Flexible and rigid wall $t_E \geq 100$ mm $\rho_E \geq 650$ kg/m ³ (for rigid wall only)	Rigid wall $t_E \geq 100$ mm $\rho_E \geq 650$ kg/m ³	Rigid wall $t_E \geq 150$ mm $\rho_E \geq 650$ kg/m ³	Rigid floor $t_E \geq 150$ mm $\rho_E \geq 650$ kg/m ³
Waste water	3.5.2.3	3.2.2.8, 3.2.2.19 (2x45° elbow) 3.2.2.21 (inclined 45°) 3.2.2.22 (collar to Mineral Wool) 3.2.2.23 (collar to CFS-B) 3.2.2.24 (collar to board) 3.2.2.25 (collar to collar) 3.2.2.27 Ellbow 87°	3.2.2.8, 3.2.2.19 (2x45° elbow) 3.2.2.21 (inclined 45°) 3.2.2.22 (collar to Mineral Wool) 3.2.2.23 (collar to CFS-B) 3.2.2.24 (collar to board) 3.2.2.25 (collar to collar) 3.2.2.27 Ellbow 87° 3.3.2.4 3.3.2.9 (pipe on the wall) 3.3.2.14 (use of oddment) 3.3.2.15 (hooks in mortar) 3.3.2.19 (pipes in corner)	3.2.2.8, 3.2.2.19 (2x45° elbow) 3.2.2.21 (inclined 45°) 3.2.2.22 (collar to Mineral Wool) 3.2.2.23 (collar to CFS-B) 3.2.2.24 (collar to board) 3.2.2.25 (collar to collar) 3.2.2.27 Ellbow 87° 3.3.2.4 3.3.2.9 (pipe on the wall) 3.3.2.14 (use of oddment) 3.3.2.15 (hooks in mortar) 3.3.2.19 (pipes in corner) 3.3.2.24 3.3.2.30 (collar to collar)	3.4.2.4 3.4.2.5 3.4.2.20 3.4.2.25 3.4.2.30 (use of oddment) 3.4.2.31 (hooks in wet mortar) 3.4.2.32 (inclined pipes 45°) 3.4.2.35 (pipes in corner) 3.4.2.36 (pipe on the wall) 3.4.2.38 (collar to collar) 3.4.2.39 (collar to collar) 3.4.2.40 (collar to Mineral Wool) 3.4.2.41 (collar to CFS-B) 3.4.2.42 (collar to board) 3.4.2.44 (pipe junction / manifold) 3.4.2.47 (Elbow 87°)

3.1 General Information Hilti Firestop Collar Endless CFS-C EL

3.1.1 Penetration seal:

Single penetration; Hilti Firestop Collar Endless CFS-C EL (A_1) to be mounted on both sides of the wall or on the underside of floor (soffit) only. Pipe diameter d_c ; refer to 3.2, 3.3, 3.4.,3.5.

3.1.2 Pipe Group/Application Group:

The Pipe Group defines the Application Group, see table 1.

Application Group 1 means one jacket on one side of the seal,

Application Group 2 means two jackets on one side of the seal.

Pipe Group is mainly defined by pipe outside diameter and isolation thickness, see table 2.

Pipe Group 1 - pipes outside nominal diameter $d_c = (32,0 \text{ mm} \leq d_c \leq 110,0 \text{ mm})$.

Pipe Group 2 - pipes outside nominal diameter $d_c = (110,1 \text{ mm} \leq d_c \leq 160,0 \text{ mm})$.

Specific situation for some pipes with outside nominal diameter $d_c = 125 \text{ mm}$, where pipes are approved within pipe group 1. (refer to 3.2, 3.3, 3.4.,3.5.)

Hilti Firestop Collar Endless CFS-C EL has to be installed in contact with pipe or pipe insulation.

No annular space between Collar and pipe/isolated pipe is permitted.

Application group:

	Flexible Wall/Shaftwall/Rigid Wall	Rigid Floor
Pipe group 1		

	Rigid Wall	Rigid Floor
Pipe group 2		

Tab.1: Application Group, defined by Pipe Group and associated substrate

3.1.3 Collar fixing

Hilti Firestop Collar Endless CFS-C EL (A₁) to be installed against the wall or floor utilising the specified number of fixing hooks. The required number and type of hooks is shown in Tab.2.

Fixing elements for hooks in flexible walls:

1. Screw Anchor Hilti HUS H6 or P6,
2. Hollow Wall Metallic Anchor Hilti HTB-S,
3. Cavity Anchor Hilti HHD-S or
4. threaded rod minimum M6 with flat washer and nut on both sides of the wall.

Fixing elements for hooks in rigid walls and floors:

1. Screw Anchor Hilti HUS H6 or P6,
2. threaded rod minimum M6 with flat washer and nut .

Fixing elements for hooks in shaft wall systems

1. Screw Anchor Hilti HUS H6 and P6 or
2. Hollow Wall Metallic Anchor Hilti HTB-S

For CFS-C EL Collar Fixing in Mineral wool board seals (refer to 3.1.14) in flexible and solid wall or solid floor to be done using threaded rods minimum M6 with flat washer and nut, penetrating the boards.

One hook (short or long) in any wall and floor should be fixed always with one fixing element. Only in shaft wall application two hooks (one long and one short) could be fixed with one fixing element.

If a threaded rod penetrates mineral wool (density 40 – 50 kg/m³) (used as back filler) it has to be ensured, that the supporting flat washer does not have direct contact to mineral wool. A metal plate/strip of at least 1mm thickness has to be placed over the wall/floor opening. The plate will be penetrated by the threaded rod. The nut presses then the flat washer to plate,

Bended hooks could be pressed into the wet gap seal, made of cementious mortar in rigid walls, ($t_E \geq 100$ mm) and rigid floors ($t_E \geq 150$ mm). For details regarding Integrity and insulation in pipe group 1 and pipe group 2 refer to 3.3.2.14 and 3.4.2.28.

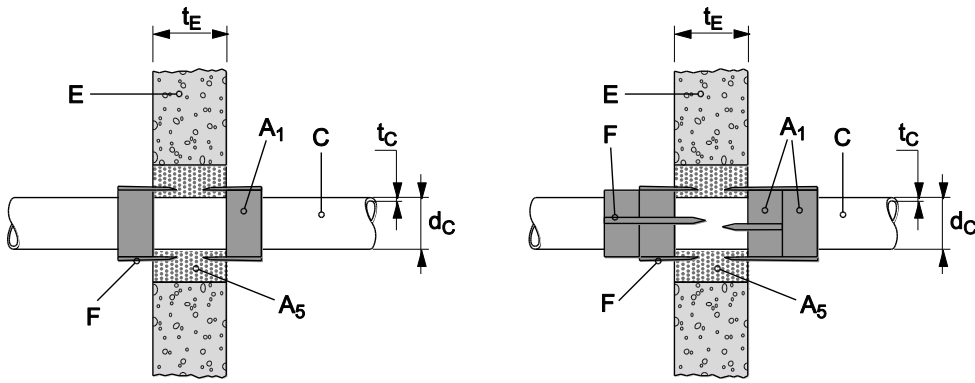

Type of wall/ Floor (material)	screw anchor Hilti HUS H6 and P6	hollow wall metallic anchor Hilti HTB-S	cavity anchor Hilti HHD-S	threaded rod M6 with disc and nut
Flexible wall	x	x	x	x
Rigid wall	x			x
Rigid floor	x			x
Shaft wall	x	x		

Tab. 2: Hook Fixing Elements for CFS-C EL, defined by building element

3.1.4 Required number of fixing hooks

Required number of hooks to fix Hilti Firestop Collar Endless CFS-C EL (A1) to

Flexible, rigid walls and rigid floors (For perpendicular penetration only)

Pipe group	Type of hooks	Nominal pipe Outside diameter d_c (mm)	Numbers of hooks					
			Max. insulation thickness (Insulation may be an acoustical insulation as described in 3.1.6 or a thermal insulation as described in 3.1.13.)					
			0 (mm)	4 mm	9 mm	13mm	19mm	25mm
1	short	16			2	2		3
		32	2	2	2	2		3
		40	2	2	2	3		3
		50	2	2	2			
		56	3	3	3			
		63	3	3	3			
		75	3	3	3			
		90	3	3	3			
		110	3	3	3		5	
		125	4	4				
		125	2 + 4	2 + 4	2 + 4		2+4	

2	short +	135	2 + 4	2 + 4	2 + 4		2+4	
	long	140	2 + 4	2 + 4	2 + 4		2+5	
		160	2 + 4	2 + 4	2 + 4		2+5	

Tab.3: requested number and specification of fixing hooks (F)

Depending from pipe dimension and required insulation thickness

The maximum distance between two hooks is 150mm. If the distance becomes bigger an additional hook (short or long) has to be used. The number of hooks for special application may be increased, but not decreased.

Special installation situation (inclined pipes, pipe coupling, elbow pipes,...) require additional hooks to fix the collar. Refer to 3.2, 3.3, 3.4, 3.5.

3.1.5 Pipe support construction

Pipes penetrating up to Ø110mm (Pipegroup 1) in rigid walls, named in **3.3.2.1; 3.3.2.2; 3.3.2.4; 3.3.2.5; 3.3.2.6;** and **Pipegroup 2** named in **3.3.2.20; 3.3.2.23; 3.3.2.24; 3.3.2.25; 3.3.2.26** have to be supported at maximum 400 mm away from both faces of any walls.

In floor penetration all pipes up to Ø110mm (Pipegroup1) named in **3.4.2.1; 3.4.2.2; 3.4.2.3; 3.4.2.4; 3.4.2.6; 3.4.2.7; 3.4.2.10; 3.4.2.11** and **Pipegroup 2 3.4.2.14; 3.4.2.15; 3.4.2.19; 3.4.2.21; 3.4.2.22** have to be supported on upside only, maximum 400mm above floor level.

Pipes and application in other chapters than named above have to be support in max. 250 mm on both side of wall (flexible and rigid) and max. 250 mm above floor. No support below floor is requested.

3.1.6 Sound decoupling insulation:

Plastic pipes could be with or without sound decoupling insulation.

Approved material:

- Foamed polyethylene based sound decoupling insulation, thickness (4mm - 9mm)
- Thermaflex, ThermoVließ B2 (Polyesther), thickness 4mm

Acoustic Pipe Insulation penetrates the wall/floor element and the Hilti Firestop Collar Endless CFS-C EL too.

Sound decoupling insulation could be used in LS and CS situation.

3.1.7 Utilization of small intumescent sections (oddments)

Minimum length of oddments is 120mm.

	Flexible wall ($t_E \geq 100\text{mm}$)	Massive wall ($t_E \geq 100\text{mm}$)	Massive floor ($t_E \geq 150\text{mm}$)	Shaftwall
Oddments allowed	Yes	Yes	Yes	No

Oddment together with an additional intumescent section has to fulfil recommended bandage length, see Annex 5. Both pieces (oddment and the additional section) have to be equipped identically with the closure plates. Those two pieces should be stuck together, than wrapped around the pipe, closed and fixed.

For pipes in application group 2 the collar containing the oddment has to be mounted to the wall/floor. The other collar must not contain oddments.

Maximum one oddment could be used within one collar. Maximum one collar for a single penetration may contain an oddment piece.

Number of hooks used to fix a collar (containing an oddment) in application group 1 to massive walls/floors: at least 4

Number of hooks used to fix a collar (containing an oddment) in application group 2 to massive walls/floors: at least 4

Details for integrity and insulation please refer to 3.3.2.13 and 3.4.2.27.

Oddments should be added to collars in perpendicular pipe position in rigid floor and walls only.

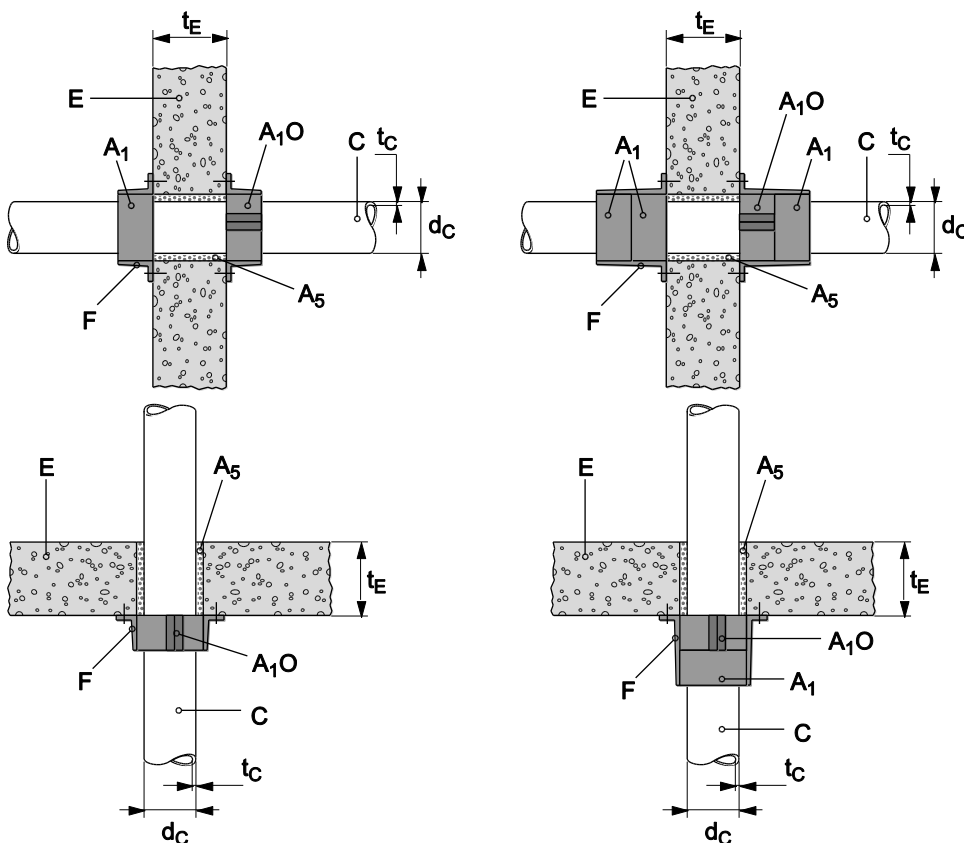

Pipes containing oddments in application group 1 and 2 in wall and floor penetration

3.1.8 Pipe orientation

Pipes in pipe group 1 (see 3.1.2) may penetrate flexible and rigid walls and rigid floors in an inclination between 45° and 90° . This is valid for flexible or rigid walls thickness ($t_E \geq 100\text{mm}$) and rigid floor ($t_E \geq 150\text{mm}$).

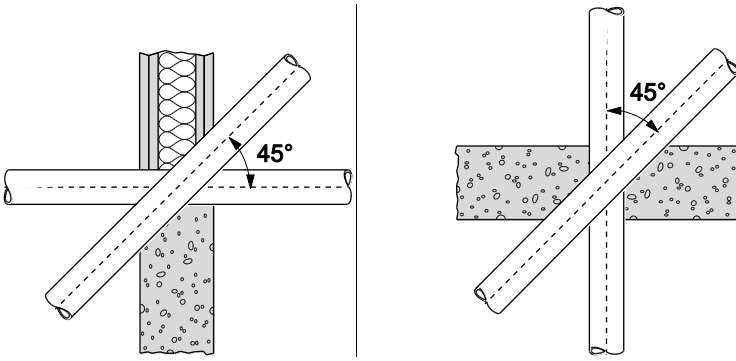

Pipes in pipe group 2 (see 3.1.2) have to penetrate walls/floors in perpendicular (90°) situation only.

3.1.9 Distance between penetrations

For pipes in application group 1 (see 3.1.2)

Flexible wall and rigid wall ($t_E \geq 100$ mm)

- distance between collars ($s_1 \geq 0$ mm)
- Max. number of pipes in line: unlimited.

Rigid floor ($t_E \geq 150$ mm):

- distance between collars ($s_1 \geq 0$ mm)
- Max. number of pipes in line: unlimited.

For pipes in application group 2 (see 3.1.2):

In rigid wall ($t_E \geq 150$ mm) :

- distance between collars ($s_1 \geq 0$ mm)
- Max. number of pipes in line: 2

Distance between two pipe clusters: ($s_2 \geq 60$ mm)

In rigid floor ($t_E \geq 150$ mm) :

- Minimum distance between collars ($s_1 \geq 0$ mm)
- Max. number of pipes in line: unlimited

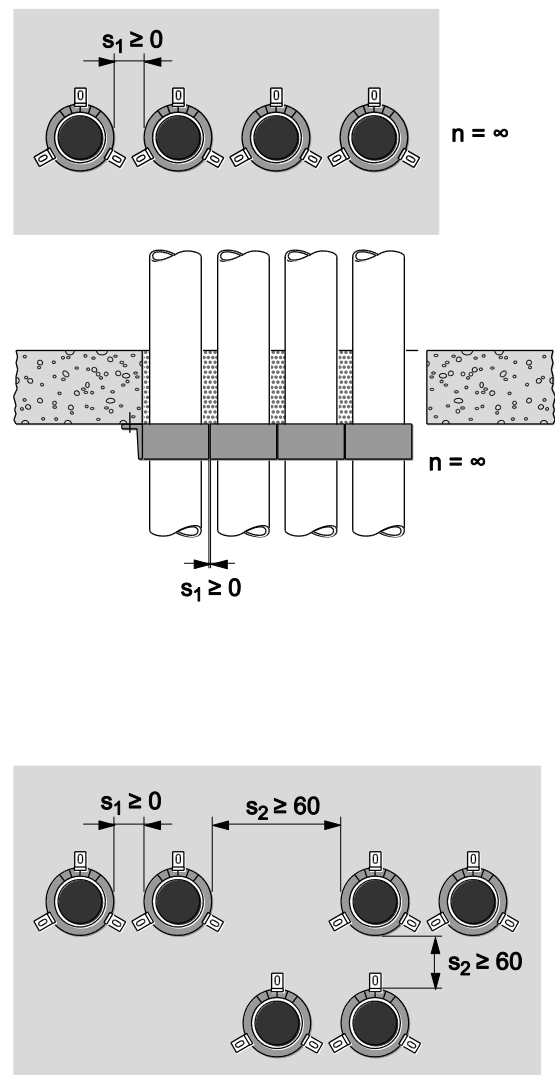

When grouped, than pipes have to be grouped in line only. This valids for any kind of wall or floor element.

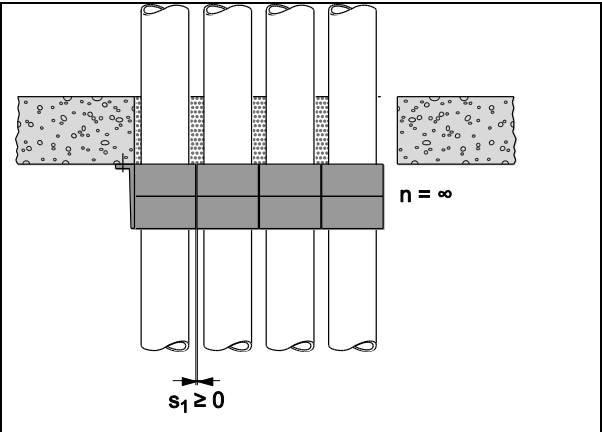

3.1.10 Mineral wool

3.1.10.1 Minimum distance Hilti Firestop Collar Endless CFS-C EL to mineral wool based pipe insulation D_w , based on Conlit 150 and Rockwool 800

CFS-C EL collar on any pipe in pipe group 1 may be used in direct contact to Conlit 150 and Rockwool 800 as a thermal insulation on metallic pipes. ($s_1 \geq 0$ mm).

Metal pipes:

- Material: refer to 3.1.12
- Outside diameter ($d_M \leq 42$ mm)
- Wall thickness of ($1,2\text{mm} \leq t_M \leq 14,2$ mm).

Thermal insulation D_w :

- Conlit 150 inside the wall/floor only
- Rockwool 800, covering the metal pipe outside the wall/floor
- Both of combustibility class A1 or A2 in accordance with EN 13501-1

3.1.10.2 Minimum distance Hilti Firestop Collar Endless CFS-C EL to mineral wool based pipe insulation D_w , on aluminium composite pipes

CFS-C EL collar on any pipe in pipe group 1 may be used in direct contact to Mineral wool pipe insulation used as thermal insulation D_w on metallic pipes and aluminium composite pipes. ($s_1 \geq 0$ mm).

Thermal insulation D_w :

- Form: prefabricated pipe shells, coated with Al-foil Reaction to fire classification (EN 13501-1): A2 or better (Melting point: $> 1000^\circ\text{C}$)
- Minimum density: $> 70\text{kg/m}^3$
- Insulation thickness $t_{RDR} DRwR > 20$ mm
- LS situation

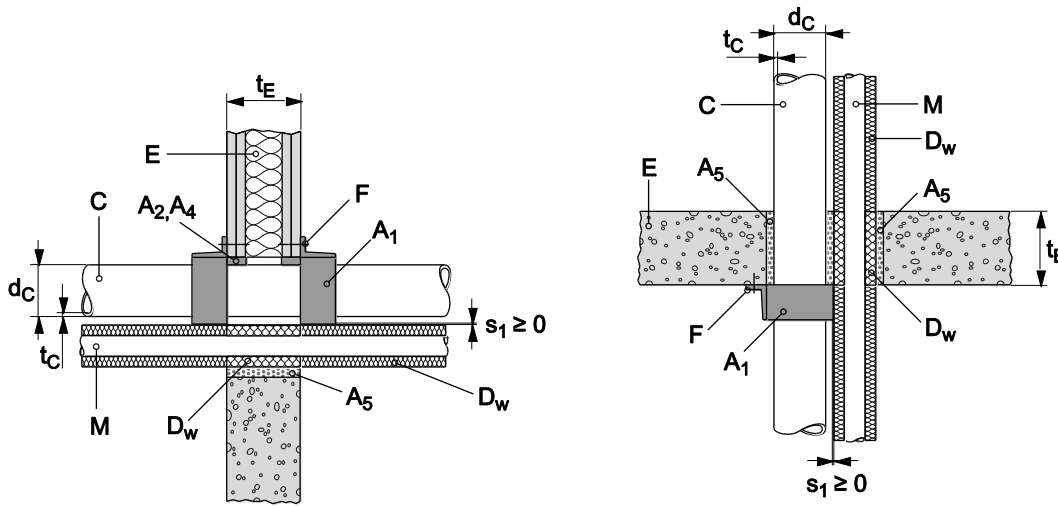

3.1.10 Minimum distance Hilti Firestop Collar Endless CFS-C EL to metal pipes, aluminium composite pipes and PP-R pipes insulated with a flexible, elastomeric thermal insulation D_E and fire stopped with Hilti CFS-B

CFS-C EL collar on any pipe in pipe group 1 may be in direct contact to metal pipes, insulated with flexible elastomeric foam and fire stopped with Hilti CFS-B. ($s_1 \geq 0$ mm). The use of Hilti CFS-B is described in detail in ETA -10/0212.

Plastic pipes, sealed with Hilti Firestop Collar Endless CFS-C EL can penetrate a wall or floor as a

- Single penetration directly beside a penetrating insulated metal pipe or aluminium composite pipe or PP-R pipe
- May penetrate the building element side by side with an insulated metal pipe as a mixed penetration.

Metal pipes:

- Made of a material described in 3.1.12
- dimensions: see specific chapters

Elastomeric foamed thermal insulation D_E in CS-situation:

- Made of a material described in 3.1.13
- D_E thickness between ($9 \text{ mm} \leq D_E \leq 35 \text{ mm}$).

In wall application (flexible wall and solid wall $t_E \geq 100$ mm) an additional protect insulation D_P has to be used on top of installed insulation hose and CFS-B.

Additional protect insulation D_P :

- Elastomeric material named in 3.1.13
- Length of ($L_D \geq 250$ mm) on each side of the wall
- D_P thickness ≥ 19 mm
- Local interrupted insulation (LI), does not pass through the wall.

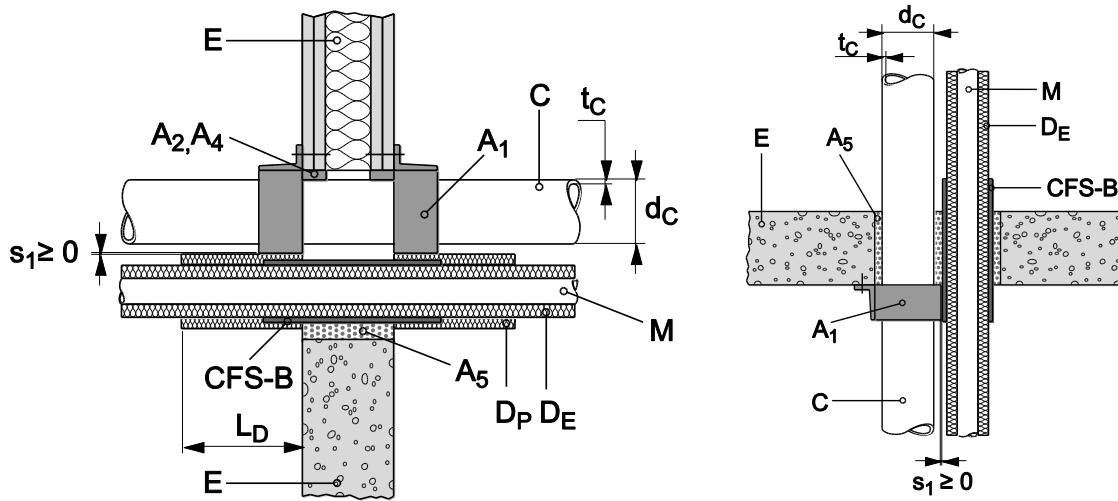

In floor application ($t_E \geq 150$ mm) there is no need for an additional protect insulation D_P .

3.1.12 Metal pipes

The field of application given above for copper pipes is also valid for other metal pipes with lower heat conductivity than copper and a melting point of minimum 1050°C , e.g. unalloyed steel, low alloyed steel, cast iron, stainless steel, Ni alloys (NiCu, NiCr, NiMo alloys) and Ni.

3.1.13 Foamed Elastomeric Thermal Insulation

The following types of foamed elastomeric insulation material may be used in direct contact

($s_1 \geq 0$ mm) to Hilti Firestop Collar Endless CFS-C EL:

Producer	Assessed type of foamed elastomeric thermal isolation
Armacell GmbH	<ul style="list-style-type: none"> ²Armaflex AF, ^{3,4}Armaflex SH, ¹Armaflex Ultima, ⁶Armaflex HT
NMC Group	<ul style="list-style-type: none"> ³Insul-Tube (nmc), ³Insul-Tube H-Plus (nmc)
Kaimann GmbH	<ul style="list-style-type: none"> ²Kaiflex KK plus, ⁴Kaiflex KK
L'Isolante K-Flex	<ul style="list-style-type: none"> ¹l'Isolante K-Flex HT, ⁵l'Isolante K-Flex ECO, ²l'Isolante K-Flex ST, ³l'Isolante K-Flex H, ²l'Isolante K-Flex ST Plus

¹ $B_L-s1,d0$; ² $B_L-s2,d0$; ³ $B_L-s3,d0$; ⁴ $C_L-s3,d0$; ⁵ $D_L-s2,d0$; ⁶ $D_L-s3,d0$ according to EN 13501-1

Named material may be used in form of an insulation hose, bandage/wrap or plates. If a protect insulation D_P is used, it should be made of the same elastomeric material as the thermal pipe isolation itself.

3.1.14 Hilti Firestop Double Board Seal

Hilti Firestop Collar CFS-C EL may be used to seal plastic pipes penetrating flexible boards installed in flexible wall and rigid wall ($t_E \geq 100$ mm) and floor ($t_E \geq 150$ mm). The flexible boards are covered within the ETA-11/0429 - Hilti Firestop Double Board Seal.

The following types of boards are approved:

- Hilti Firestop Board CFS-CT B 1S (refer to Annex 2, 2.2.6)
- Hilti Firestop Board CFS-CT B 2S (refer to Annex 2, 2.2.6)
- Hilti Firestop Coating CFS-CT applied on uncoated mineral wool boards refer to Annex 2, 2.2.6)

Only pipes of pipe group 1 ($d_c \leq 110\text{mm}$) may be used in combination with Hilti Firestop Double Board Seal.

Gap seal:

- Between pipe and board with Hilti Firestop Acrylic Sealant CFS-S ACR
- Between pipe and basement with Hilti Firestop Acrylic Sealant CFS-S ACR.
- Gap pipe to basement ($s_3 \geq 0\text{ mm}$)

Distance in between installed pipes (s_1):

- In rigid wall and flexible wall is ($s_1 \geq 80\text{ mm}$).
- In a rigid floor is ($S_1 \geq 100\text{ mm}$).

Collar fixing: refer to 3.1.3

Pipe grouping:

In rigid wall and flexible wall ($t_E \geq 100\text{ mm}$):

- Pipes have to be group in line, not in clusters
- An unlimited number of pipes group in line is approved.

In rigid floor ($t_E \geq 150\text{ mm}$):

- Pipes have to be group in line, not in clusters
- An unlimited number of pipes group in line is approved.

In flexible wall / rigid wall and rigid floor boards have to be installed flush with surface. If the basement is thicker than 100 mm the free space between both (flush with surface installed boards) have to be filled with mineral wool according detailed description in ETA-11/0429 - Hilti Firestop Double Board Seal.

3.1.15 Non-regulated acoustic PP-pipes

The following types of mineral reinforced non-regulated PP-pipes are approved in different configurations :

- Coes Blue Power
- Coes PhoNo Fire
- Geberit Silent PP
- Marley Silent
- Ostendorf Skolan db
- Pipelife Master 3
- Poloplast Polokal NG
- Poloplast Polokal 3S
- Poloplast Polokal XS
- Rehau Raupiano Plus
- KE KELIT PhonEx AS
- Valsir Triplus

- Valsir Silere
- Wavin SiTech
- Wavin AS

3.2 Flexible walls

3.2.1 Specific characteristics for Flexible walls ($t_E > 100$ mm)

3.2.1.1 Flexible walls – wall construction

The wall must have a minimum thickness of 100 mm and comprise timber or steel studs lined on both faces with minimum 2 layers of 12,5 mm thick boards.

For timber stud walls there must be a minimum distance of 100 mm of the seal to any stud and the cavity between stud and seal must be closed. A minimum 100 mm insulation of Class A1 or A2 (in accordance with EN 13501-1) has to remain in the cavity between stud and seal. In steel stud construction the space between linings has not to be completely filled with insulation material, especially in the neighbourhood to the seal. Nevertheless the wall construction has to be set up according requirements given in EN 1366-3:2009 or the construction itself has been classified according EN 13501-2.

The wall comprises timber or steel studs lined on both faces with minimum 2 layers of 12,5 mm thick boards. A higher number of board layers is accepted if the overall board layer thickness is equal or bigger than tested. A higher overall board layer thickness is accepted, if the number of board layers is equal or bigger than tested.

The boards are according EN 520 type F or according the specification of the tested and approved flexible wall construction system according EN 13501-2.

An aperture framing inside the wall is not required.

3.2.1.2 Annular gap

Annular gaps around pipes in flexible walls should be filled with either

- Gypsum based mortar
- Hilti Firestop Acrylic sealant CFS-S ACR.
- Joint filler has to be installed from both sides of the flexible wall
- Minimum installation depth of ($t_{A2} \geq 25$ mm)
- Gap width : 0 – 15 mm.
- Backfilling is not requested.

3.2.1.3 Collar fixing

Hilti Firestop Collar Endless CFS-C EL (A_1) has to be fixed with hooks (F) on the wall. The requested number and type of hooks is shown in 3.1.3, Tab.2.

Hooks fixing in flexible walls is described in 3.1.4 and Tab.3.

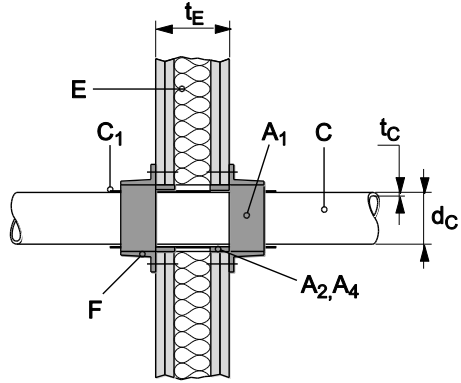
<p align="center">Annular gap seal (drawings show insulated and non-insulated pipes)</p>	
<p>Plastic Pipe, penetrating a flexible wall construction, with or without sound decoupling insulation (C_1), gap sealed with gypsum or CFS-S ACR acrylic sealant.</p> <p>Back filling is not requested.</p>	

3.2.2 Penetrating services in 100mm flexible wall

All test results from flexible wall testing ($t_E \geq 100$ mm) are applicable for rigid walls ($t_E \geq 100$ mm).

3.2.2.1 PE pipes acc. EN 1519-1, EN 12666-1, EN 12201-2 and ABS-pipes acc. EN 1455-1 and SAN+PVC-pipes acc. EN 1565-1 in flexible wall, ($t_E > 100$ mm), pipe group 1, EI 120 - U/U

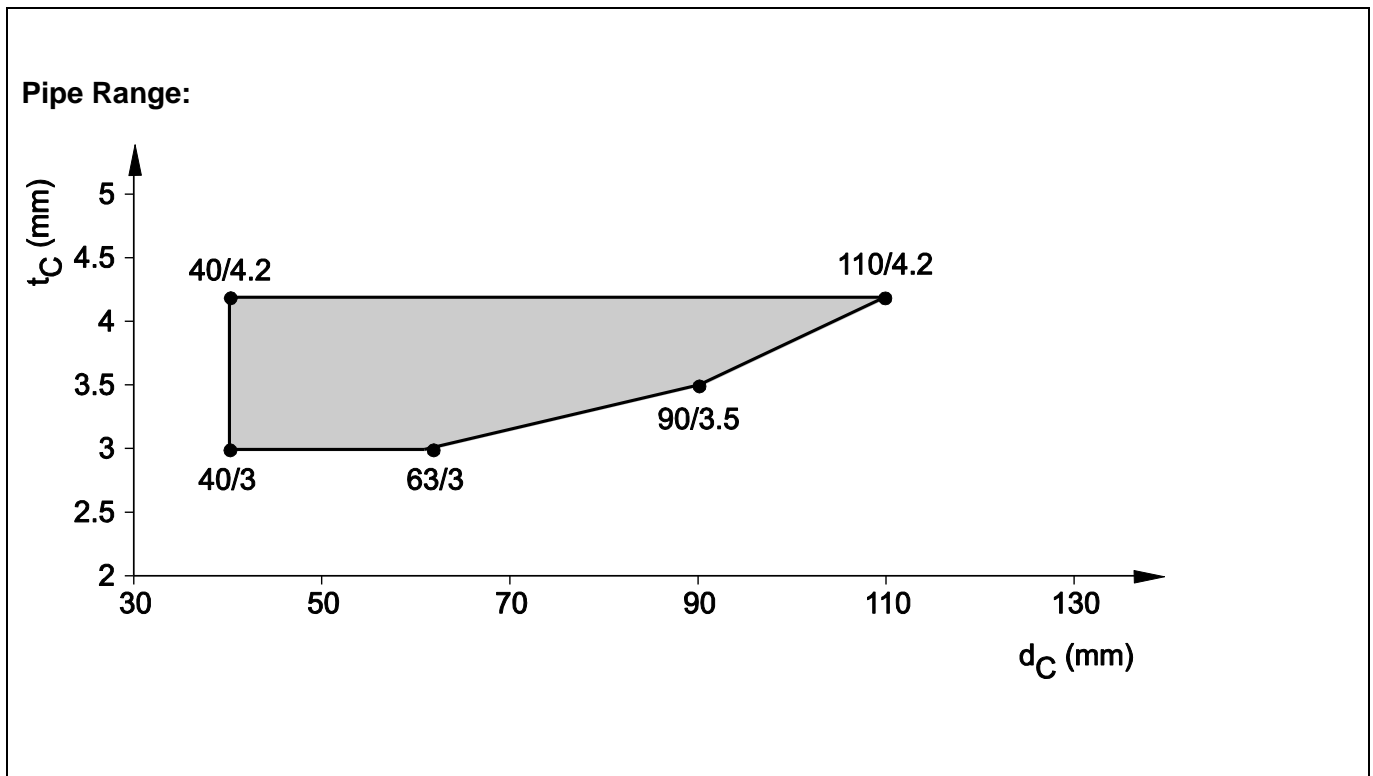

3.2.2.2 ABS- pipes acc. EN 1455, EN 15493 and SAN+PVC-pipes acc. EN 1565-1,
in flexible wall, ($t_E \geq 100$ mm), pipe group 1, EI 90 - U/U

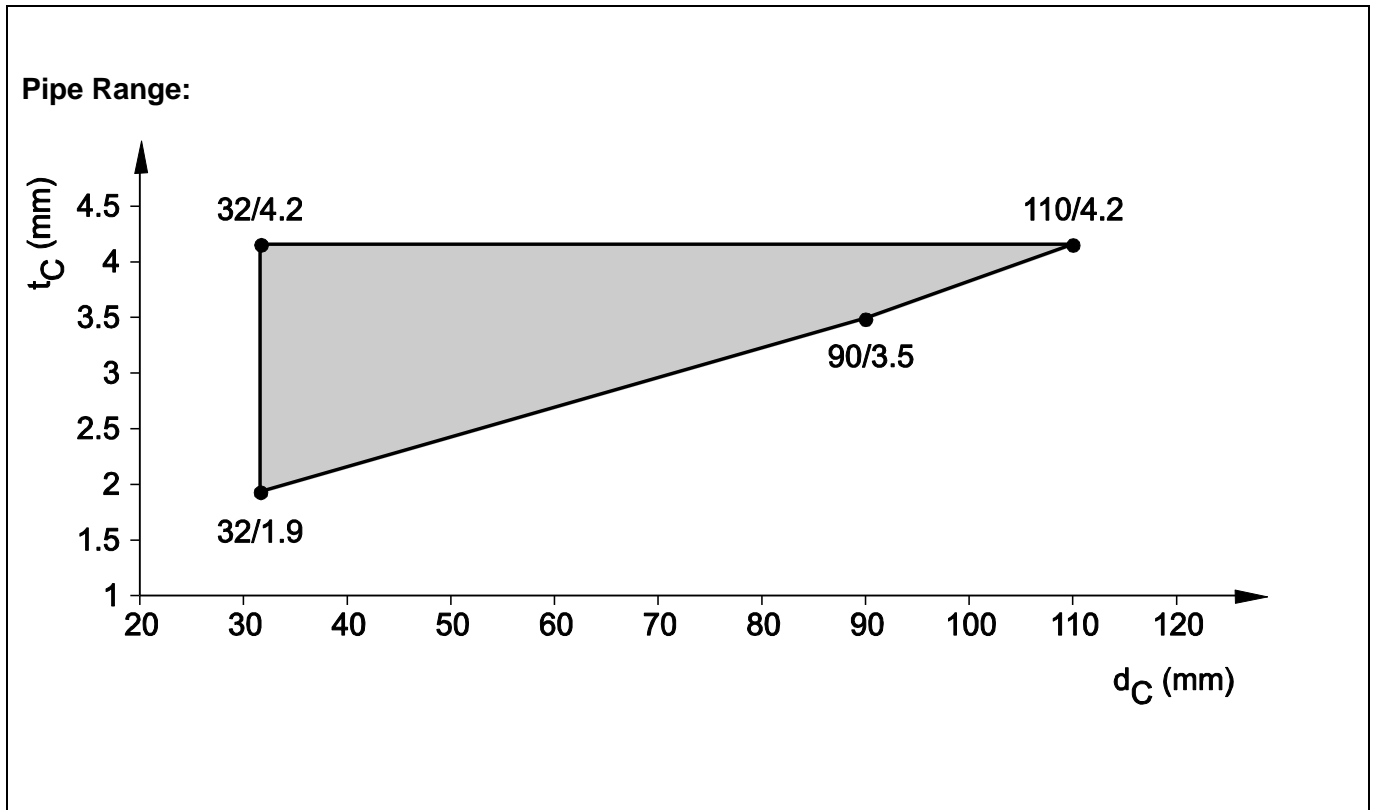

3.2.2.3 ABS- pipes acc. EN 1455, EN 15493 and SAN+PVC-pipes acc. EN 1565-1,
in flexible wall, ($t_E > 100$ mm), pipe group 1, EI 60 - U/U

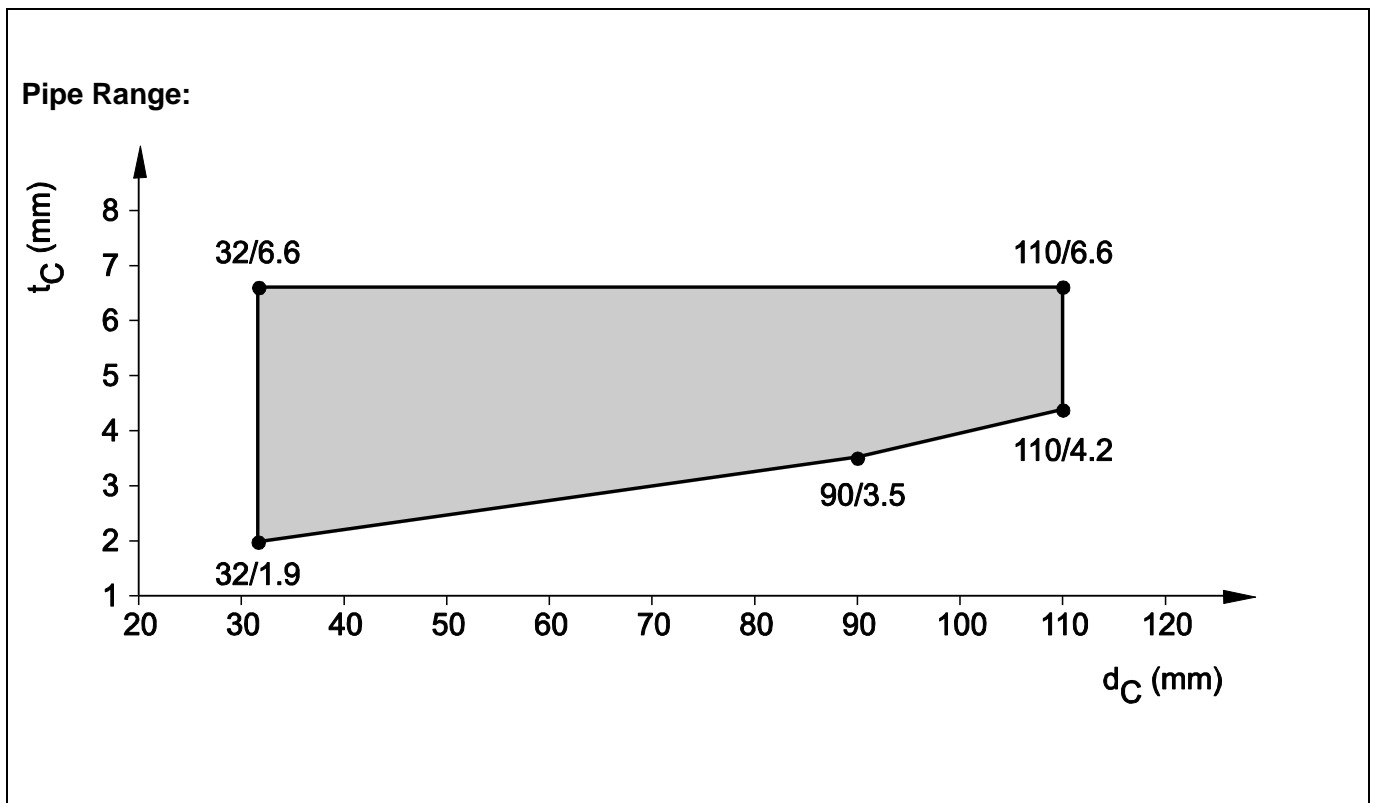

3.2.2.4 PE pipes acc. EN15494, EN 12201-2 and DIN 8074/75 in flexible wall,
 ($t_E > 100$ mm), pipe group 1, EI 120 - U/U

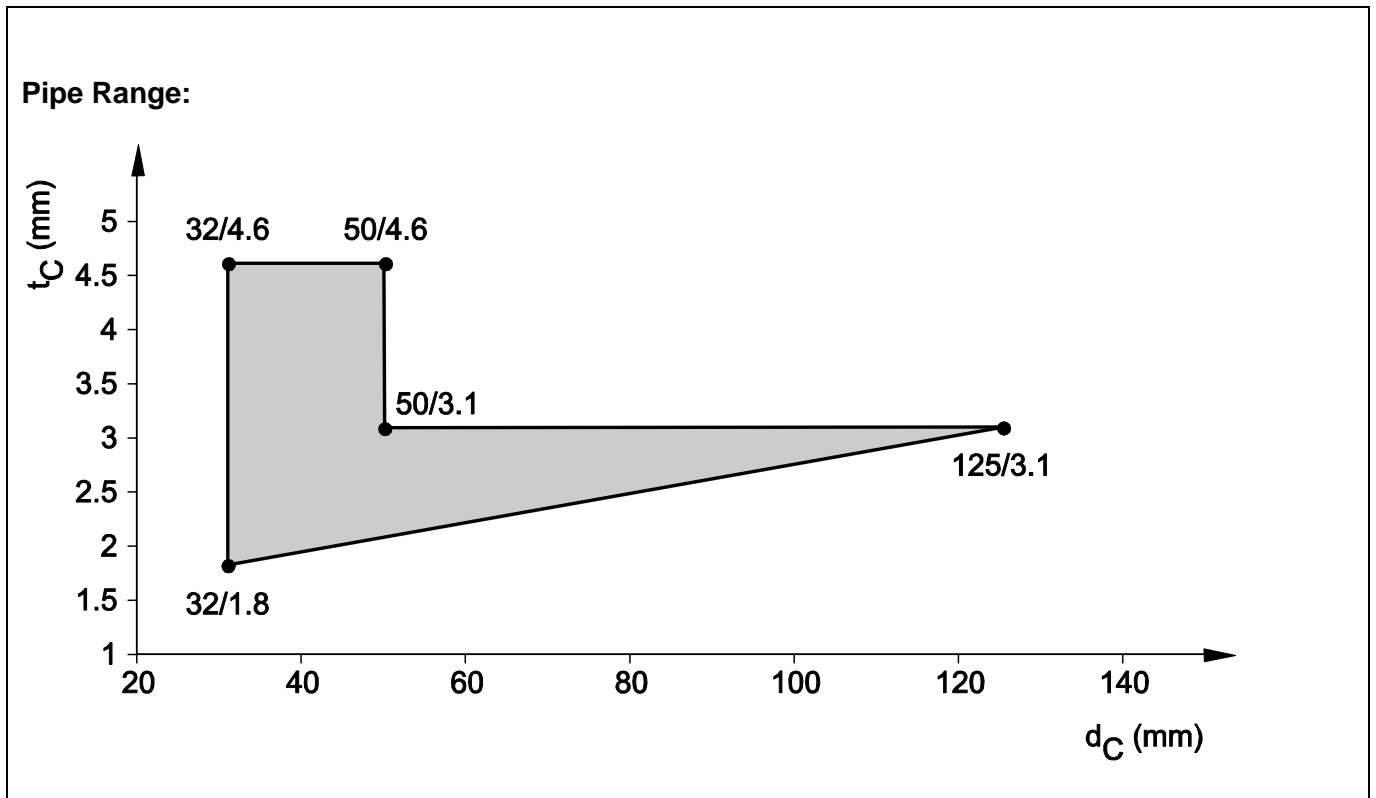

3.2.2.5 PE pipes acc. EN15494, EN12201-2 and DIN 8074/75 in flexible wall,
 ($t_E > 100$ mm), pipe group 1, EI 90 - U/U

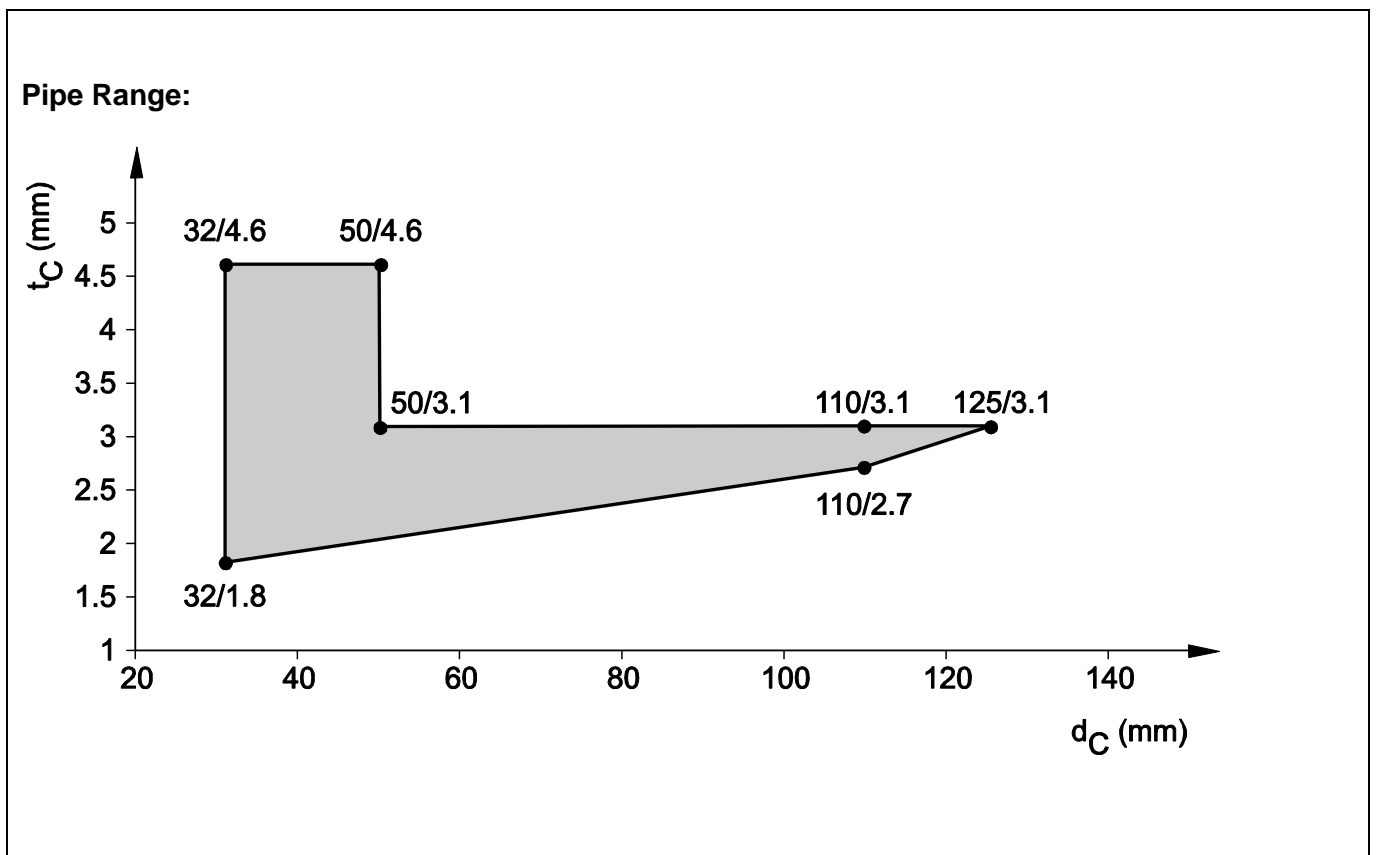

3.2.2.6 PE pipes acc. EN15494, EN 12201-2 and DIN 8074/75 in flexible wall

($t_E \geq 100$ mm), pipe group 1, EI 120 - U/C

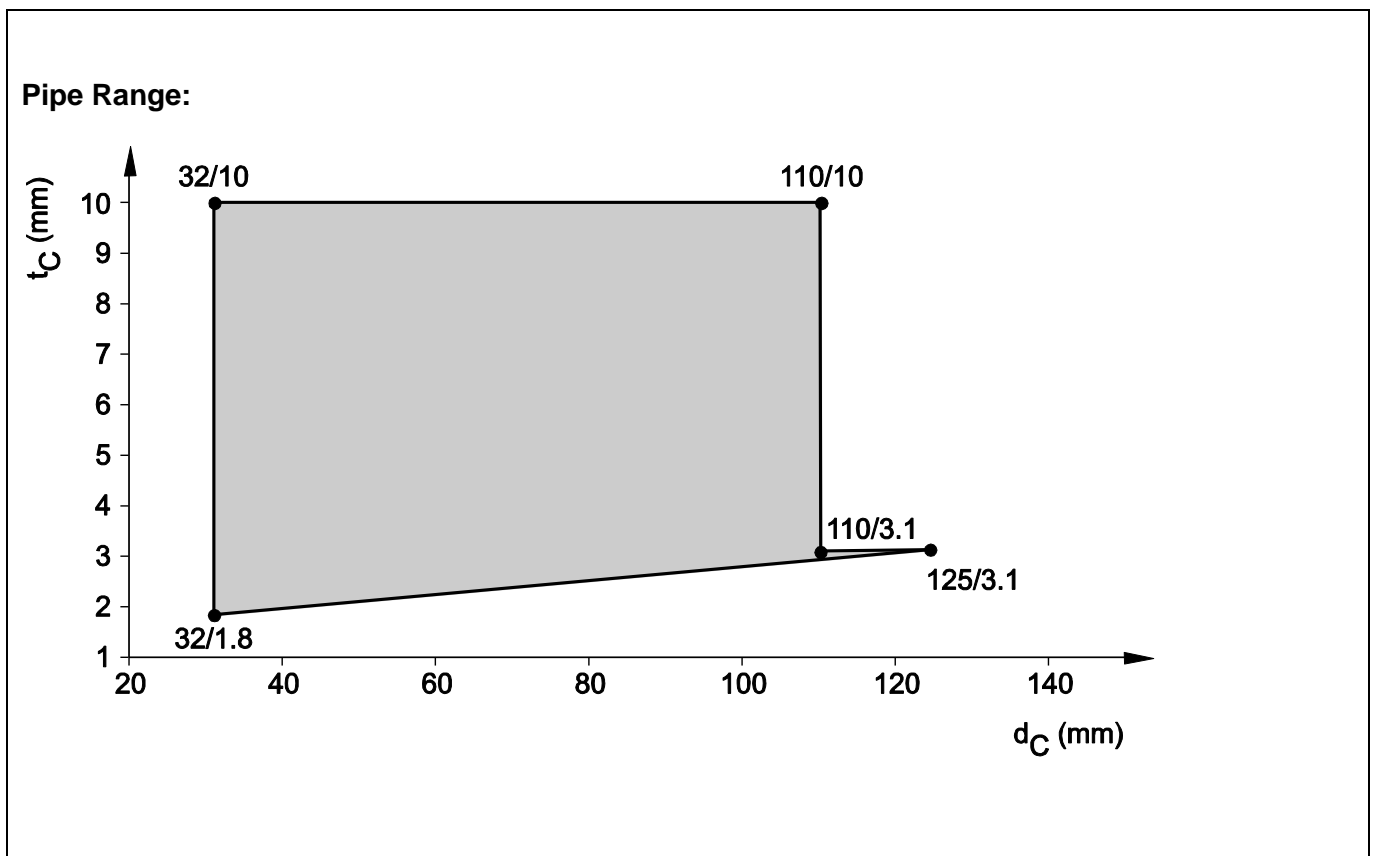

3.2.2.7 PE pipes acc. EN15494, EN 12201-2 and DIN 8074/75 in flexible wall

($t_E \geq 100$ mm), pipe group 1, EI 90 - U/C

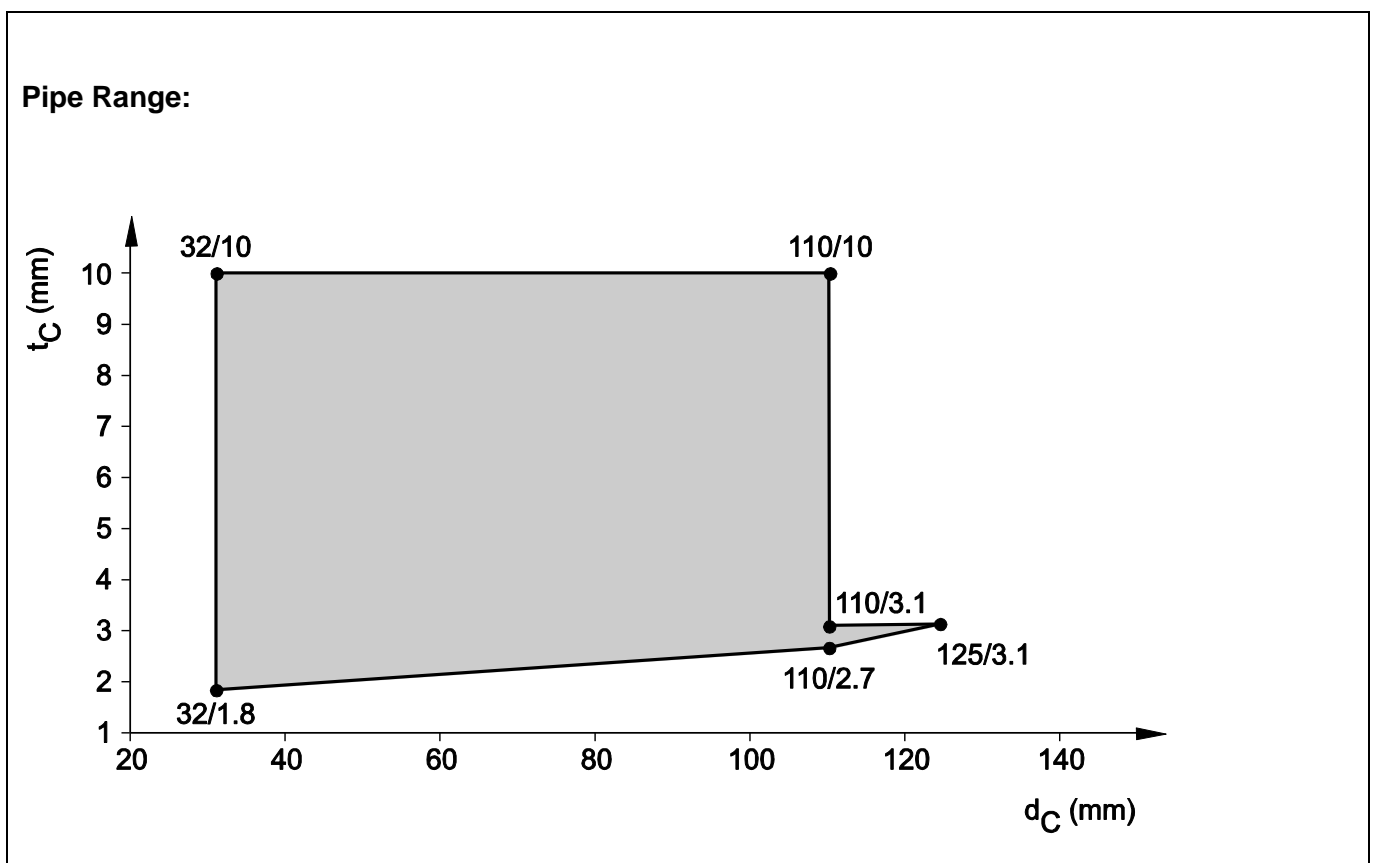

3.2.2.8 PVC pipes acc. EN 1452-1, EN 1329-1, EN 1453-1, EN 1566-1, EN ISO 15493 and DIN 8061/62 in flexible wall ($t_E \geq 100$ mm), pipe group 1, EI 120 - U/U

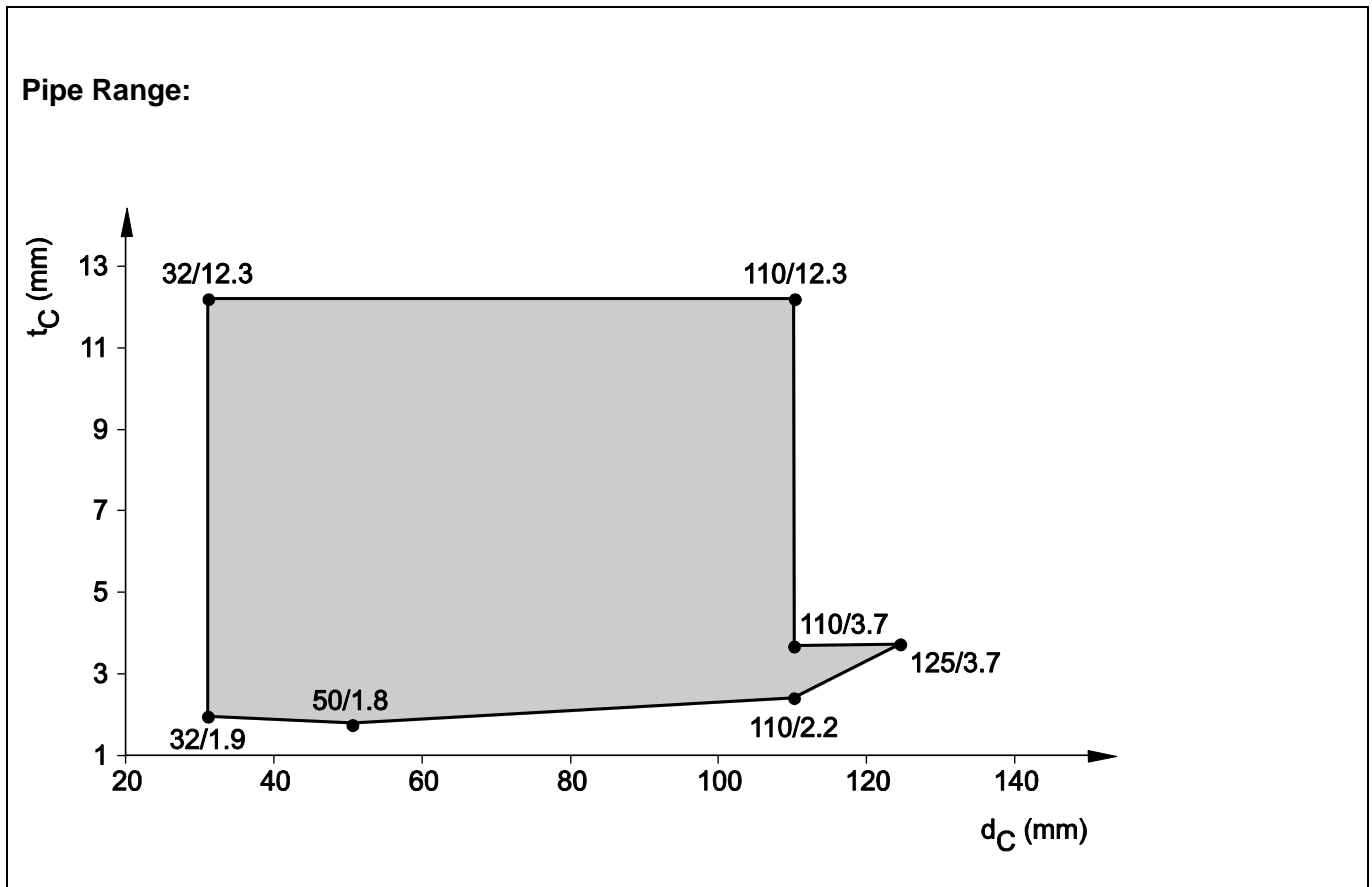

3.2.2.9 PP pipes , non-regulated in flexible wall ($t_E \geq 100$ mm), pipe group 1, EI 90 - U/U

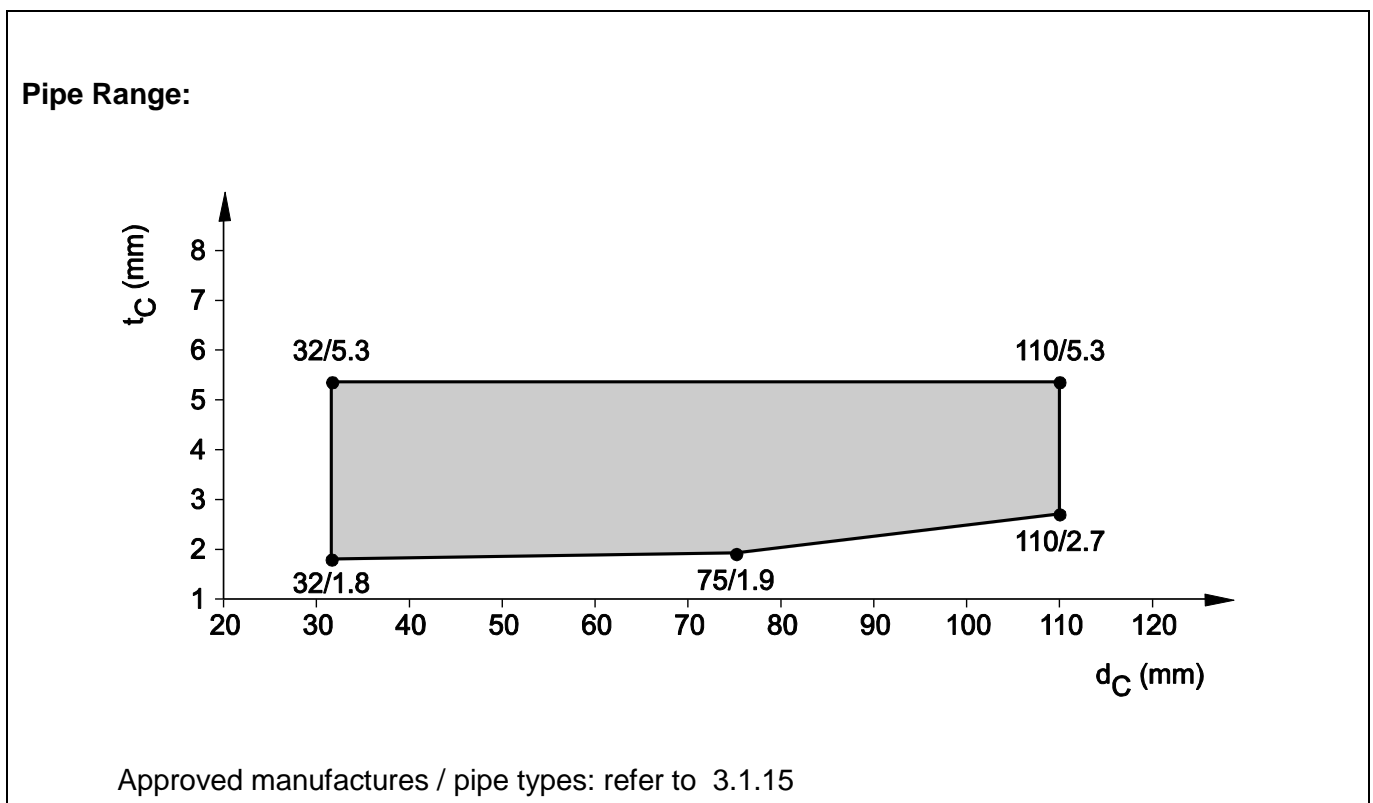

**3.2.2.10 PP pipes acc. EN1451-1 and DIN 8077/78,
in flexible wall ($t_E \geq 100$ mm), pipe group 1, EI 120 - U/U**

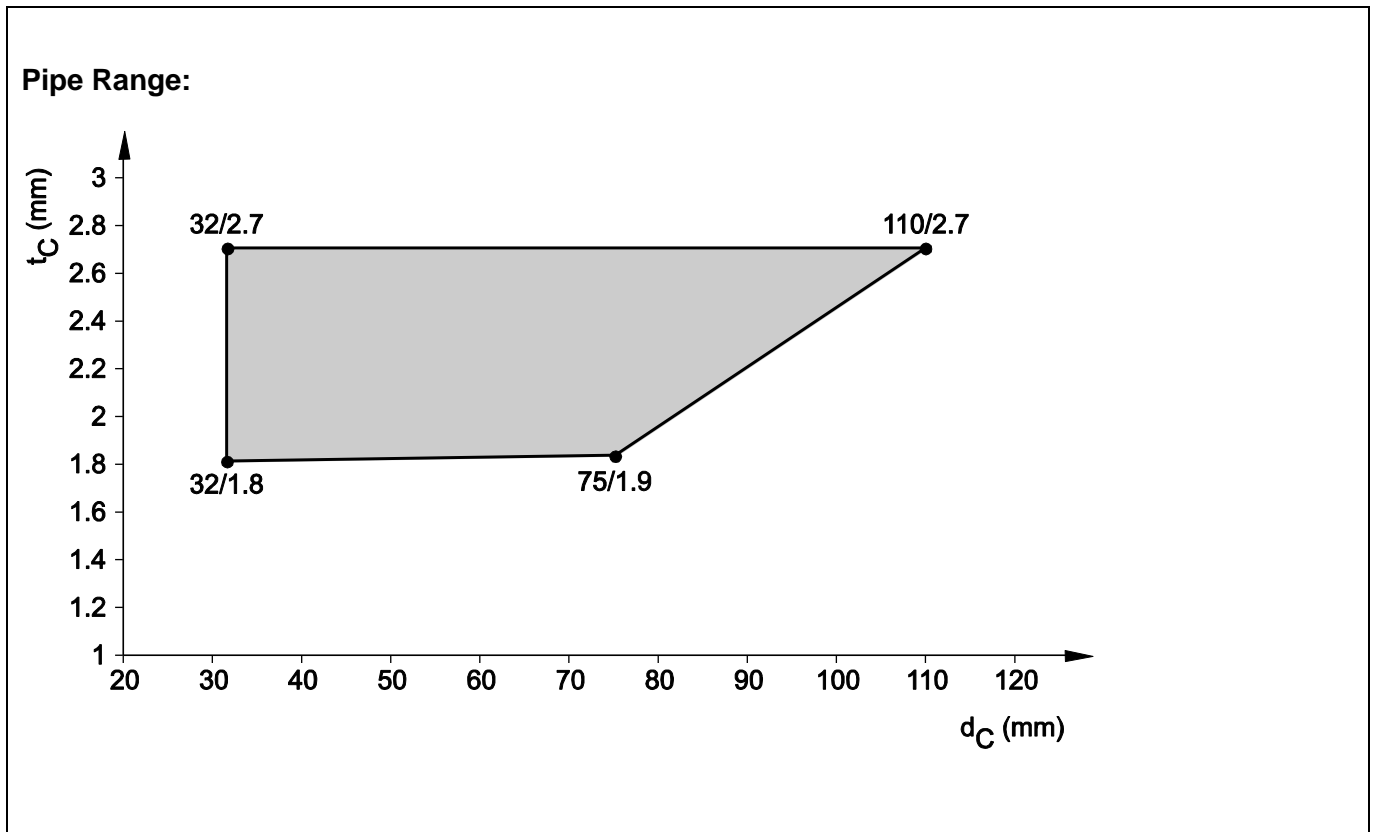

**3.2.2.11 PP pipes acc. EN1451-1 and DIN 8077/78, in flexible wall ($t_E \geq 100$ mm),
pipe group 1, EI 120 - U/C**

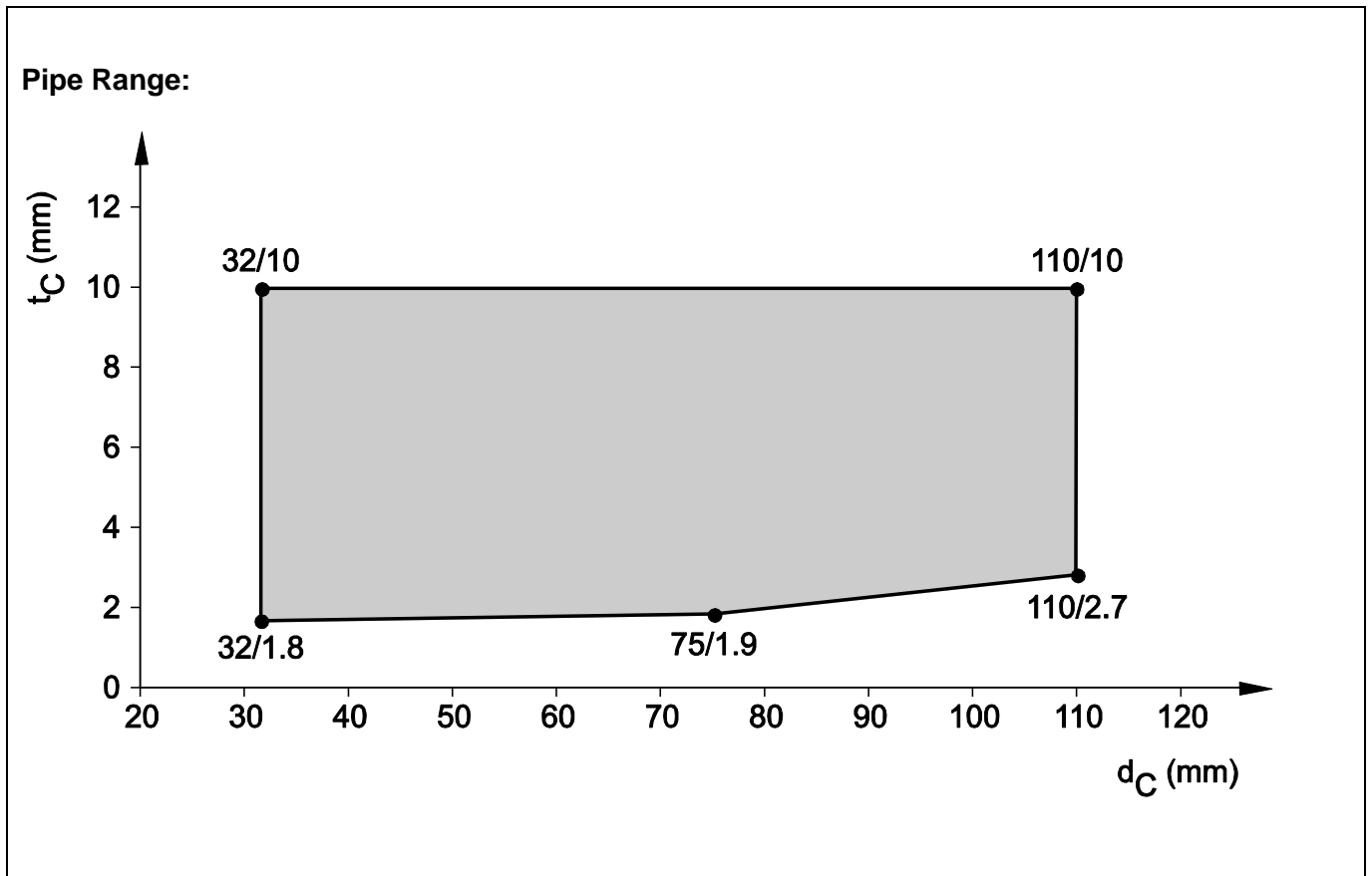

**3.2.2.12 PE pipes , non-regulated (Geberit Silent dB20) ,
in flexible wall ($t_E \geq 100$ mm), pipe group 1, EI 120 - U/U**

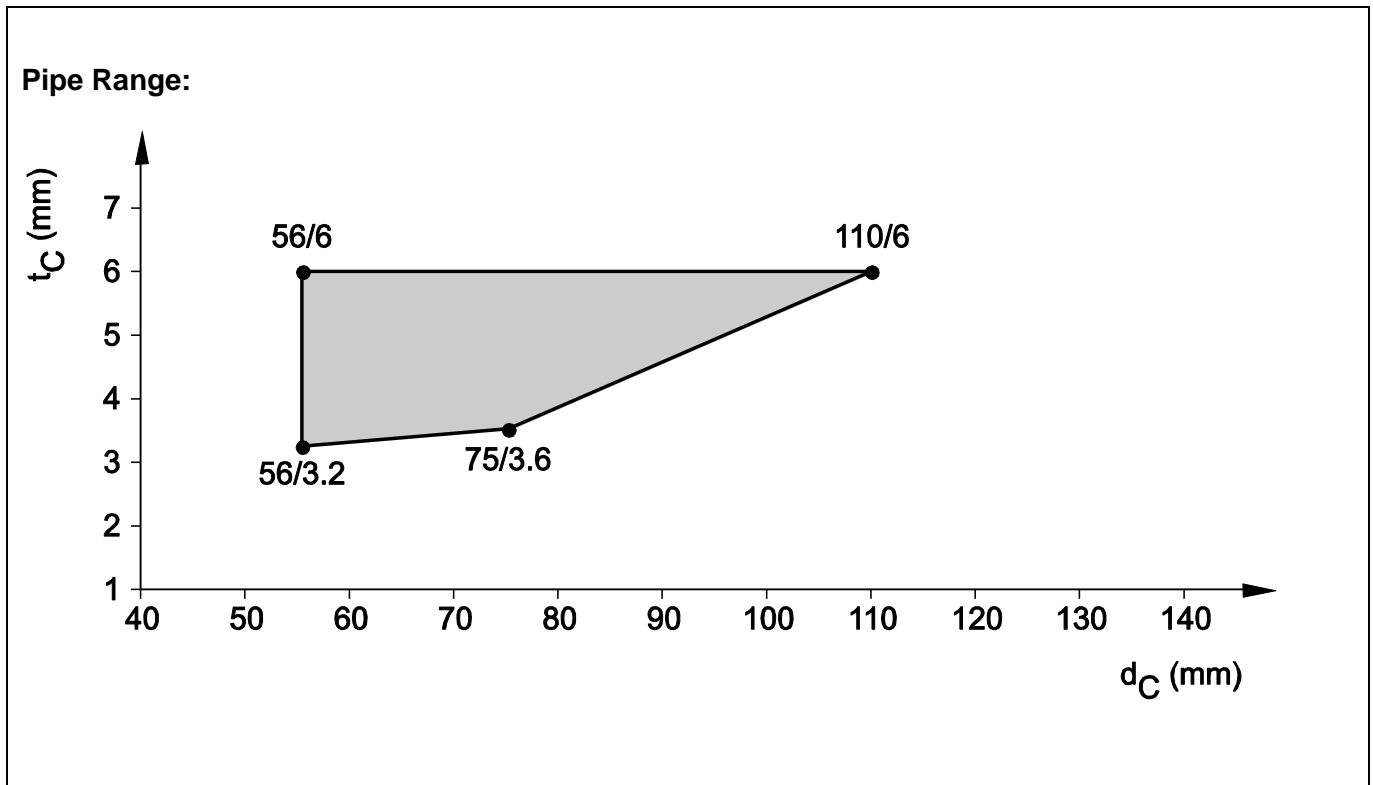

**3.2.2.13 PVC- pipes, non-regulated (Friatec Friaphon),
in flexible wall ($t_E \geq 100$ mm), pipe group 1, EI 90 - U/U**

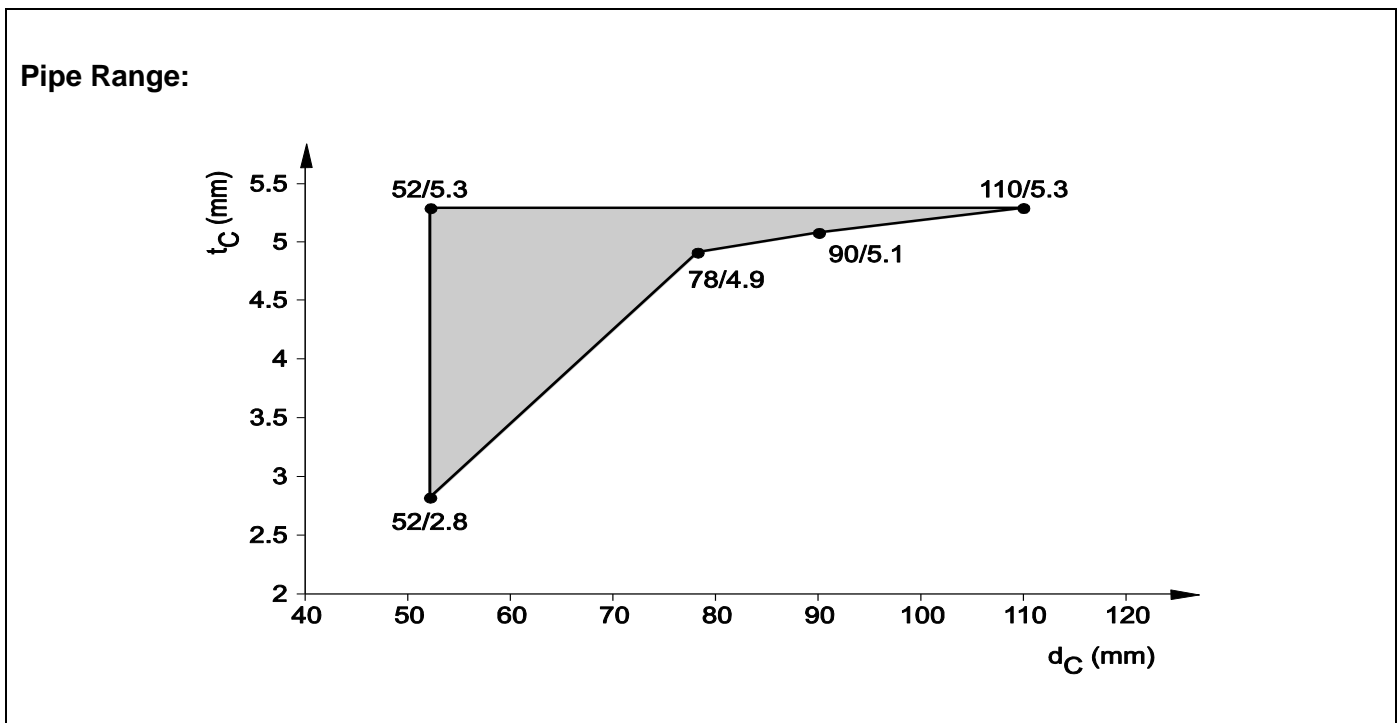

**3.2.2.14 Pneumatic dispatch system, PVC pipe acc. DIN 6660,
in flexible wall ($t_E \geq 100$ mm), pipe group 1, EI 90 - U/U**

Situation for EI 90 - U/U:

- PVC pipe acc. DIN 6660

- Pipe diameter ($d_c = 110 \text{ mm}$)
- Pipe wall thickness ($t_c = 2,3 \text{ mm}$)
- Pipe inclination : ($45^\circ \leq \text{inclination} \leq 90^\circ$)
- Mixed penetration is allowed: pipe together with maximum three cables, see below

Maximum approved cable size is:

- NYM-J 3x2,5 mm²
- J-Y (St) Y 6 x 2 x 0,6 mm²
- 2 x 2,5 mm²

Cable in direct contact to pipe, single or bunched cables approved.

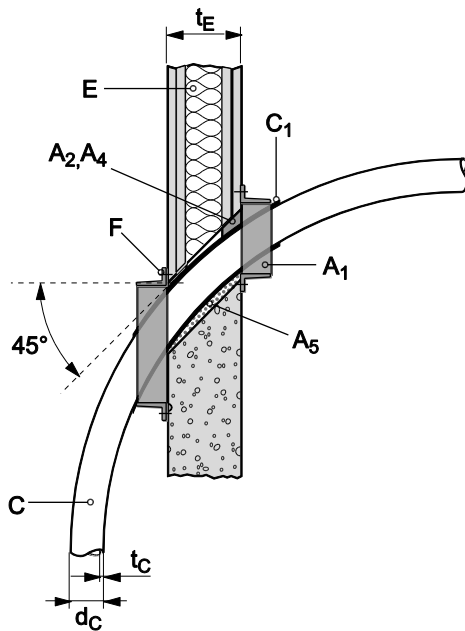

3.2.2.15 PE-X pipe acc. EN 15875 (Rehau Rautitan flex),

in flexible wall ($t_E > 100 \text{ mm}$), pipe group 1, EI 120 - U/C

Situation for EI 120 - U/U:

- PE-X acc. EN 15875 (Rehau Rautitan flex),
- Pipe diameter ($16 \text{ mm} \leq d_c \leq 32 \text{ mm}$)
- Pipe wall thickness ($2,2 \text{ mm} \leq t_c \leq 4,4 \text{ mm}$)
- Pipe inclination : 90°

Flexible, elastomeric thermal insulation D_E :

- Type of material: refer to 3.1.13
- Thickness of D_E : ($9 \text{ mm} \leq t_D \leq 25 \text{ mm}$)
- Insulation length: ($L_D \geq 250 \text{ mm}$) on pipes on both sides of the wall.
- LS and CS situation approved

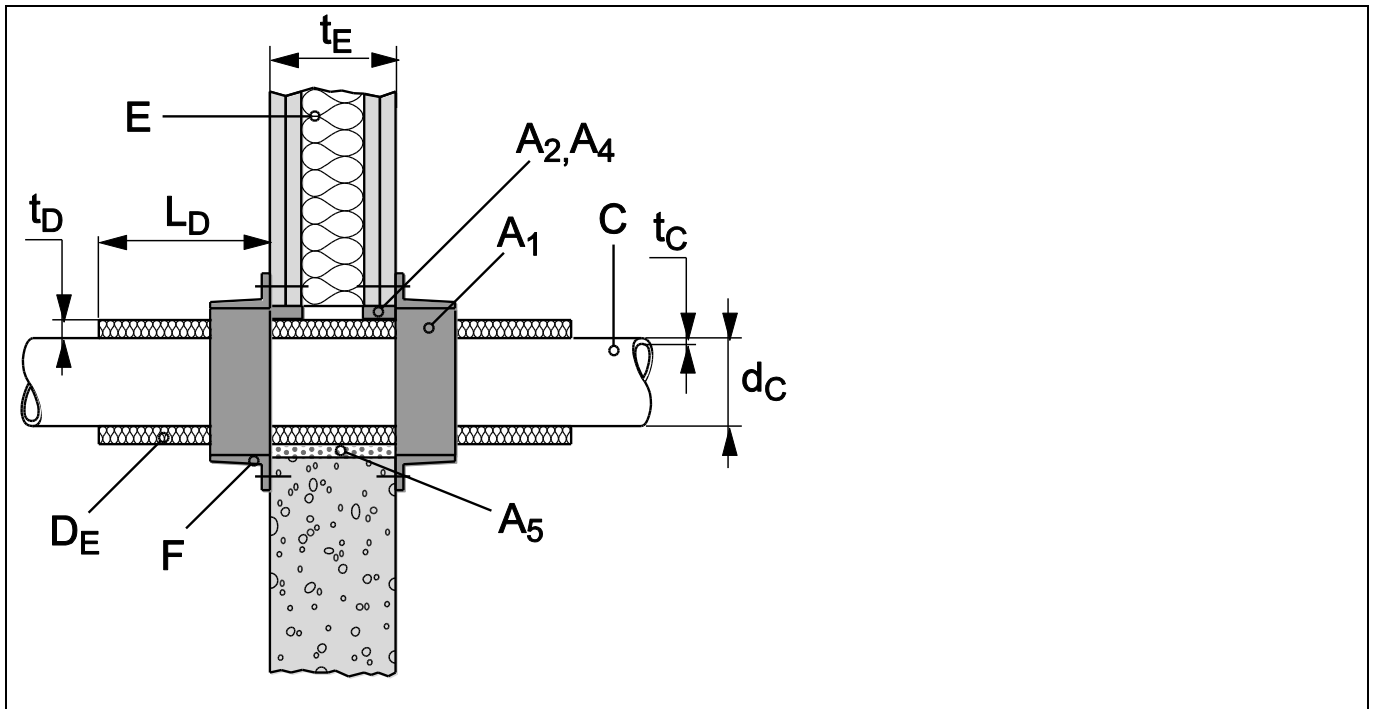

**3.2.2.16 PP-R pipe acc. EN 15874 (Aquatherm fusiolen = aquatherm green pipe S),
in flexible wall ($t_E \geq 100$ mm), pipe group 1, EI 120 - U/C**

Situation for EI 120 - U/U:

- PP-R acc. EN 15874 (Aquatherm fusiolen = aquatherm green pipe S),
- Pipe diameter ($16 \text{ mm} \leq d_C \leq 32 \text{ mm}$)
- Pipe wall thickness ($2,2 \text{ mm} \leq t_C \leq 4,4 \text{ mm}$)
- Pipe inclination : 90°

Flexible, elastomeric thermal insulation D_E :

- Type of material: refer to 2.1.13
- Thickness of D_E : ($9 \text{ mm} \leq t_D \leq 25 \text{ mm}$)
- Insulation length: ($L_D \geq 250 \text{ mm}$) on pipes on both sides of the wall.
- LS and CS situation approved

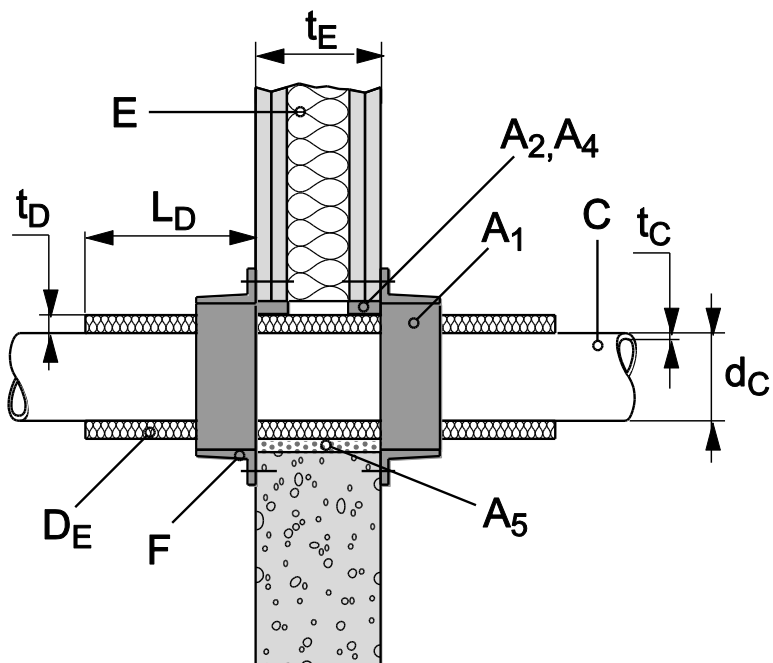

3.2.2.17 PP pipes , non-regulated

in flexible wall ($t_E \geq 100$ mm), pipe group 1, EI 120 - U/U, Pipe coupling

Situation for EI 120 - U/U :

- Pipe coupling inside the wall, half in the wall or outside the wall
- Type of pipes: refer to 3.1.15
- Range of pipes : refer to 3.2.2.9
- Gap filler: Hilti CFS-FIL
- Annular Gap: 5 – 40 mm
- Depth t_{A3} to fill with Hilti CFS-FIL: ($t_{A3} \geq 25$ mm)

Backfilling:

- In drywall no backfilling required
- In rigid wall backfilling with mineral wool, refer to Annex 2, chapter 2.2

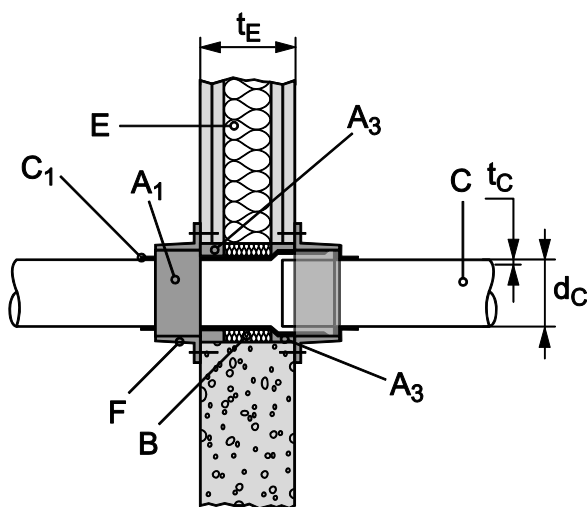

Requested number of hooks on CFS-C EL to seal pipes, penetrating a flexible wall/ rigid wall ($t_E > 100$ mm) and using a linear pipe coupling. (no elbow) .If pipe insulation thickness is between 0 and 4mm use the number of hooks indicated for 4 mm. If pipe insulation thickness is between 4 and 9 mm use the number of hooks indicated for 9 mm.

Pipe outside nominal diameter d_c (mm)	Acoustic Pipe Insulation Thickness t_D (mm) (incoming pipe / outgoing pipe)		
	0	4	9
32	2 / 2	2 / 2	2 / 2
50	2 / 2	2 / 2	2 / 3
75	3 / 3	3 / 3	3 / 3
90	3 / 3	3 / 3	3 / 3
110	3 / 4	3 / 4	3 / 4

3.2.2.18 PP pipes, non-regulated, (see 3.2.2.9),

in flexible wall ($t_E \geq 100\text{mm}$), pipe group 1, EI 90 - U/U, Elbow Pipes 87°

Situation for EI 90 - U/U:

- Elbow Pipe 87° inside the wall, half in the wall or outside the wall, covered by CFS-C EL
- Type of pipes: refer to 3.1.15
- Range of pipes : refer to 3.2.2.9
- On one side the pipe may run with zero distance to penetrated wall ($s_3 > 0\text{ mm}$).

Gap size and gap filler:

In flexible wall application ($t_E \geq 100\text{ mm}$):

- Gap filler: Hilti CFS-S ACR or gypsum
- Annular gap: 0 – 15 mm
- Depth t_{A2} to filled with Hilti CFS-S ACR or gypsum: ($t_{A2} \geq 25\text{ mm}$)
- No backfilling required

In rigid wall application ($t_E \geq 100\text{mm}$):

- Gap filler: Hilti CFS-S ACR
 - Annular gap: 0 – 15mm
 - Depth t_{A2} to filled with Hilti CFS-S ACR: ($t_{A2} \geq 25\text{ mm}$)
 - No backfilling required
- or:
- Gap filler: cementious Mortar M10 acc.EN 998-2
 - Annular gap: 0 – 40mm
 - Depth to fill with cementious Mortar M10: to fill over entire wall thickness

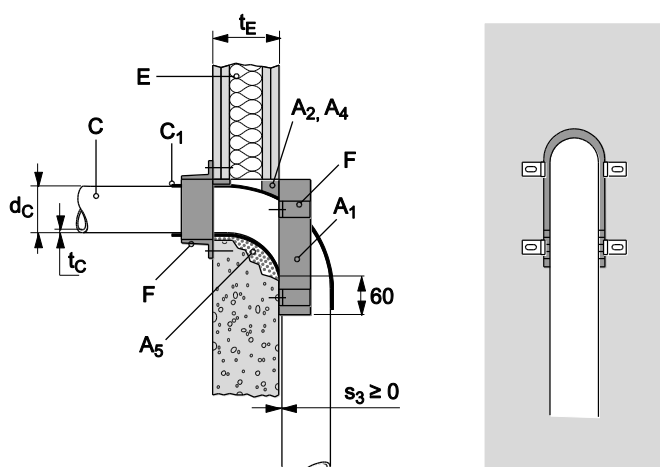

Requested number of hooks:

Pipe outside nominal diameter d_c (mm)	Acoustic Pipe Insulation Thickness t_D (mm) (no elbow side - horizontal running pipe / elbow side - vertical running pipe)		
	0	4	9
32	2 / 2	2 / 2	2 / 2
50	2 / 2	2 / 2	2 / 3
75	3 / 3	3 / 3	3 / 3
90	3 / 3	3 / 3	3 / 3
110	3 / 4	3 / 4	3 / 4

If pipe insulation thickness is between 0 and 4mm use the number of hooks indicated for 4 mm. If pipe insulation thickness is between 4 and 9 mm use the number of hooks indicated for 9 mm.

**3.2.2.19 PP pipes, non-regulated (see 3.2.2.9),
in flexible wall ($t_E \geq 100$ mm) pipe group 1, EI 60 - U/U, Pipe coupling**

Situation for EI 60 - U/U:

- Pipe coupling inside the wall, half in the wall or outside the wall, covered by CFS-C EL
- Type of pipes: refer to 3.1.15
- Range of pipes : refer to 3.2.2.9

Gap size and gap filler:

In flexible wall application ($t_E \geq 100$ mm),:

- Gap filler: Hilti CFS-S ACR or gypsum
- Annular gap: 0 – 15 mm
- Depth t_{A2} to filled with Hilti CFS-S ACR or gypsum: ($t_{A2} \geq 25$ mm)
- No backfilling required

In rigid wall application ($t_E \geq 100$ mm),:

- Gap filler: Hilti CFS-S ACR
- Annular gap: 0 – 15 mm
- Depth t_{A2} to filled with Hilti CFS-S ACR: ($t_{A2} \geq 25$ mm)
- No backfilling required
- or**
- Gap filler: cementious Mortar M10 acc.EN 998-2
- Annular gap: 0 – 40 mm
- Depth to fill with cementious Mortar M10: to fill over entire wall thickness

For EI 60 classification or less: refer to 3.2.2.18

For EI 120 classification or less refer to 3.2.2.16

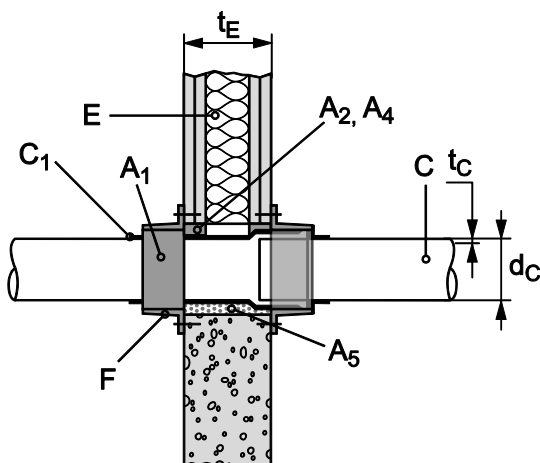

Requested number of hooks:

Pipe outside nominal diameter d_c (mm)	Acoustic Pipe Insulation Thickness t_D (mm) (incoming pipe / outgoing pipe)		
	0	4	9
32	2 / 2	2 / 2	2 / 2
50	2 / 2	2 / 2	2 / 3
75	3 / 3	3 / 3	3 / 3
90	3 / 3	3 / 3	3 / 3

110

3 / 4

3 / 4

3 / 4

If pipe insulation thickness is between 0 and 4mm use the number of hooks indicated for 4 mm. If pipe insulation thickness is between 4 and 9 mm use the number of hooks indicated for 9 mm.

3.2.2.20 PP pipes, non-regulated (see 3.2.2.9) in flexible wall ($t_E \geq 100$ mm),

pipe group 1, EI 60 - U/U, 2x45° Elbow Pipes

Situation for EI 60 - U/U:

- 2x45° Elbow Pipes, inside the wall, half in the wall or outside the wall, covered by CFS-C EL
- Type of pipes: refer to 3.1.15
- Range of pipes : refer to 3.2.2.9
- On one side of the wall pipe runs parallel to wall with zero distance ($s_3 \geq 0$ mm).

Gap size and gap filler:

In flexible wall application ($t_E \geq 100$ mm),:

- Gap filler: Hilti CFS-S ACR or gypsum
- Annular gap: 0 – 15 mm
- Depth t_{A2} to filled with Hilti CFS-S ACR or gypsum: ($t_{A2} \geq 25$ mm)
- No backfilling required

In rigid wall application ($t_E \geq 100$ mm),:

- Gap filler: Hilti CFS-S ACR
- Annular gap: 0 – 15 mm
- Depth t_{A2} to filled with Hilti CFS-S ACR: ($t_{A2} \geq 25$ mm)
- No backfilling required
- **or**
- Gap filler: cementious Mortar M10 acc.EN 998-2
- Annular gap: 0 – 40 mm
- Depth to fill with cementious Mortar M10: to fill over entire wall thickness

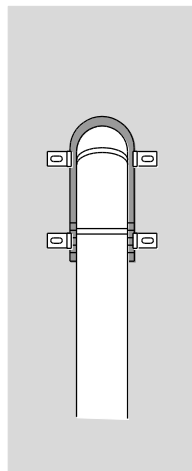
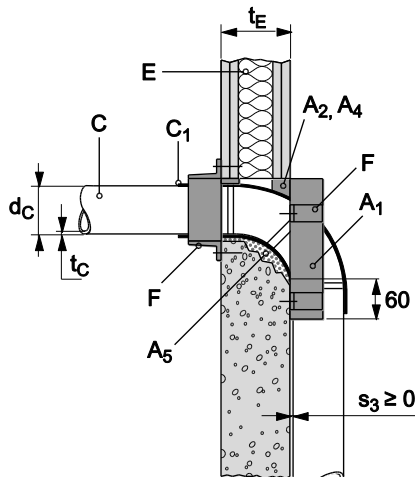

Requested number of hooks:.

Pipe outside nominal diameter d_c (mm)	Acoustic Pipe Insulation Thickness t_D (mm) (no elbow side - horizontal running pipe / elbow side - vertical running pipe)		
	0	4	9
32	2 / 2	2 / 2	2 / 2
50	2 / 2	2 / 2	2 / 3
75	3 / 3	3 / 3	3 / 3
90	3 / 3	3 / 3	3 / 3
110	3 / 4	3 / 4	3 / 4

If pipe insulation thickness is between 0 and 4mm use the number of hooks indicated for 4 mm. If pipe insulation thickness is between 4 and 9 mm use the number of hooks indicated for 9 mm.

3.2.2.21 All pipes named in 3.2.2.1; 3.2.2.2; 3.2.2.3; 3.2.2.4; 3.2.2.5; 3.2.2.8; 3.2.2.9; 3.2.2.10; 3.2.2.12; in flexible wall ($t_E \geq 100$ mm), pipe group 1, EI 90 - U/U, Inclined Pipes 45°

Situation for EI 90 - U/U:

- Pipe inclination ($45^\circ \leq \text{inclination} \leq 90^\circ$)
- Type of pipes: refer to 3.2.2.1; 3.2.2.2; 3.2.2.3; 3.2.2.4; 3.2.2.5; 3.2.2.8; 3.2.2.9; 3.2.2.10; 3.2.2.12;
- Range of pipes : refer to 3.2.2.1; 3.2.2.2; 3.2.2.3; 3.2.2.4; 3.2.2.5; 3.2.2.8; 3.2.2.9; 3.2.2.10; 3.2.2.12;

Excluded are only pipes with an outside nominal diameter ($d_c > 110\text{mm}$) .

Gap size and gap filler:

In flexible wall application ($t_E \geq 100$ mm),:

- Gap filler: Hilti CFS-S ACR or gypsum
- Annular gap: 0 – 15 mm
- Depth t_{A2} to filled with Hilti CFS-S ACR or gypsum: ($t_{A2} \geq 25$ mm)
- No backfilling required

In rigid wall application ($t_E \geq 100$ mm),:

- Gap filler: Hilti CFS-S ACR
 - Annular gap: 0 – 15 mm
 - Depth t_{A2} to filled with Hilti CFS-S ACR: ($t_{A2} \geq 25$ mm)
 - No backfilling required
- or**
- Gap filler: cementious Mortar M10 acc.EN 998-2

- Annular gap: 0 – 40 mm
- Depth to fill with cementitious Mortar M10: to fill over entire wall thickness

Requested number of hooks:

Pipe outside nominal diameter d_c (mm)	Acoustic Pipe Insulation Thickness t_D (mm)		
	identical on both sides of the flexible wall/rigid wall		
	0	4	9
32	3	3	3
50	3	3	3
75	3	4	4
90	4	4	5
110	5	5	5

If pipe insulation thickness is between 0 and 4mm use the number of hooks indicated for 4 mm. If pipe insulation thickness is between 4 and 9 mm use the number of hooks indicated for 9 mm.

3.2.2.22 Zero distance CFS-C EL to mineral wool insulated pipes

3.2.2.22.1 All pipes named in 3.2.2.1; 3.2.2.2; 3.2.2.3, 3.2.2.4; 3.2.2.5; 3.2.2.8; 3.2.2.9; 3.2.2.10; 3.2.2.12 approved in flexible wall ($t_E \geq 100$ mm), pipe group 1, EI 90 - U/U, Zero distance Collar to mineral wool insulation on metal pipes

Situation for EI 90 - U/U (refer to 3.1.10) :

- Collar CFS-C EL on plastic pipe in direct contact to mineral wool insulation ($s_1 \geq 0$ mm), used as thermal insulation on metal pipes.
- Type of pipes: refer to 3.2.2.1; 3.2.2.2; 3.2.2.3, 3.2.2.4; 3.2.2.5; 3.2.2.8; 3.2.2.9; 3.2.2.10; 3.2.2.12
- Range of pipes : refer to 3.2.2.1; 3.2.2.2; 3.2.2.3, 3.2.2.4; 3.2.2.5; 3.2.2.8; 3.2.2.9; 3.2.2.10; 3.2.2.12; Excluded are only pipes with an outside nominal diameter ($d_C > 110$ mm).

Mineral wool based thermal insulation:

- Used types of Insulation: refer to 3.1.10.1

Pipes diameter ($d_M \leq 42$ mm):

- Insulation thickness ($t_D \geq 19$ mm) within the flexible wall ($t_E = LD$)
- Insulation thickness ($t_D \geq 20$ mm) on metal pipes on both sides of the wall
- Insulation length $LD \geq 1000$ mm on both sides of the wall
- LS situation

Pipes diameter (42 mm $< d_M \leq 89$ mm):

- Insulation thickness ($t_D \geq 19$ mm) within the flexible wall ($t_E = LD$)
- Insulation thickness ($t_D \geq 30$ mm) on metal pipes on both sides of the wall
- Insulation length $LD \geq 1000$ mm on both sides of the wall
- LS situation

Metal pipes, insulated by named above types of mineral wool products:

- Pipe diameter ($d_M \leq$ of 89 mm)
- Pipe wall thickness of ($1,2$ mm $\leq t_M \leq 14,2$ mm)
- Covered material types– refer to 3.1.12.

Gap size and gap filler:

In flexible wall application ($t_E \geq 100$ mm),:

- Gap filler: Hilti CFS-S ACR or gypsum
- Annular gap: 0 – 15 mm
- Depth t_{A2} to filled with Hilti CFS-S ACR or gypsum: ($t_{A2} \geq 25$ mm)
- No backfilling required

In rigid wall application ($t_E \geq 100$ mm),:

- Gap filler: Hilti CFS-S ACR
 - Annular gap: 0 – 15 mm
 - Depth t_{A2} to filled with Hilti CFS-S ACR: ($t_{A2} \geq 25$ mm)
 - no backfilling required
- or**

- Gap filler: cementitious Mortar M10 acc.EN 998-2
- Annular gap: 0 – 40 mm
- Depth to fill with cementitious Mortar M10: to fill over entire wall thickness

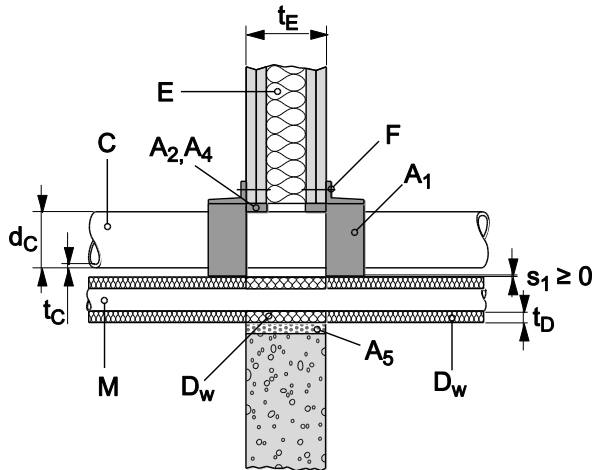

3.2.2.22.2 All pipes named in 3.2.2.1; 3.2.2.2; 3.2.2.3, 3.2.2.4; 3.2.2.5; 3.2.2.8; 3.2.2.9; 3.2.2.10; 3.2.2.12 approved in flexible wall ($t_E \geq 100$ mm), pipe group 1, EI 90-U/U, Zero distance Collar to mineral wool insulation on metallic pipes

Situation for EI 90 - U/U (refer to 3.1.11) :

- Collar CFS-C EL on plastic pipe in direct contact to mineral wool insulation ($s_1 \geq 0$ mm), used as thermal insulation on metal pipes.
- Type of pipes: refer to 3.2.2.1; 3.2.2.2; 3.2.2.3, 3.2.2.4; 3.2.2.5; 3.2.2.8; 3.2.2.9; 3.2.2.10; 3.2.2.12
- Range of pipes: refer to 3.2.2.1; 3.2.2.2; 3.2.2.3, 3.2.2.4; 3.2.2.5; 3.2.2.8; 3.2.2.9; 3.2.2.10; 3.2.2.12

Excluded are only pipes with outside nominal diameter ($d_C > 110$ mm).

Mineral wool based thermal insulation:

- Used types of Insulation: refer to 3.1.10.1

Pipes diameter ($d_M \leq 42$ mm):

- Insulation thickness ($t_D \geq 19$ mm) within the flexible wall ($t_E = LD$)
- Insulation thickness ($t_D \geq 20$ mm) on metal pipes on both sides of the wall
- Insulation length $LD \geq 1000$ mm on both sides of the wall
- LS situation

Pipes diameter ($42 \text{ mm} < d_M \leq 114,3$ mm):

- Insulation thickness ($t_D \geq 30$ mm) within the flexible wall ($t_E = LD$)
- Insulation thickness ($t_D \geq 30$ mm) on metal pipes on both sides of the wall
- Insulation length $LD \geq 1000$ mm on both sides of the wall
- LS situation

Metal pipes, insulated by named above types of mineral wool products:

- Pipe diameter ($d_M \leq 114,3$ mm)
- Pipe wall thickness of ($1,2 \text{ mm} \leq t_M \leq 14,2$ mm)
- Covered material types– refer to 3.1.12., excluded material is copper

Gap size and gap filler:

In flexible wall application ($t_E \geq 100$ mm),:

- Gap filler: Hilti CFS-S ACR or gypsum

- Annular gap: 0 – 15 mm
- Depth t_{A2} to be filled with Hilti CFS-S ACR or gypsum: ($t_{A2} \geq 25$ mm)
- No backfilling required

In rigid wall application ($t_E \geq 100$ mm):

- Gap filler: Hilti CFS-S ACR
- Annular gap: 0 – 15 mm
- Depth t_{A2} to be filled with Hilti CFS-S ACR: ($t_{A2} \geq 25$ mm)
- no backfilling required
- **or**
- Gap filler: Hilti CFS-S ACR
- Annular gap: 0 – 40 mm
- Depth t_{A2} to be filled with Hilti CFS-S ACR: ($t_{A2} \geq 25$ mm)
- Back filled with mineral wool, refer to Annex 2, chapter 2.2
- **or**
- Gap filler: cementitious Mortar M10 acc. EN 998-2
- Annular gap: 0 – 40 mm
- Depth to be filled with cementitious Mortar M10: to fill over entire wall thickness

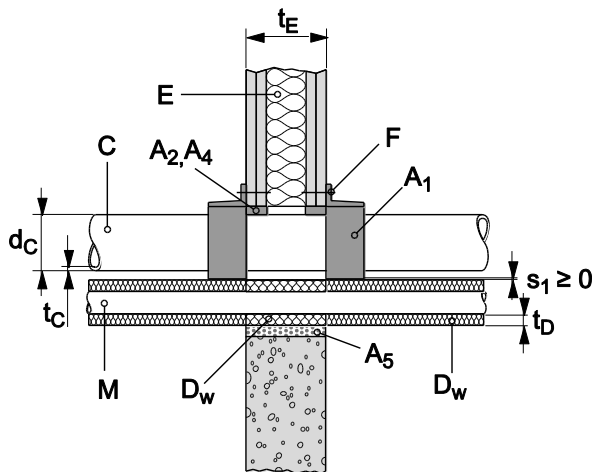

3.2.2.22.3 All pipes named in 3.2.2.1; 3.2.2.2; 3.2.2.3, 3.2.2.4; 3.2.2.5; 3.2.2.8; 3.2.2.9;

3.2.2.10; 3.2.2.12 in flexible wall ($t_E \geq 100$ mm), pipe group 1, EI 90 – U/U,

Zero distance Collar to mineral wool insulation on aluminium composite pipes

Situation for EI 90-U/U (refer to 3.1.11):

- Zero distance between CFS-C EL collar and CFS-B, wrapped around an elastomeric foamed thermal insulation on aluminium composite pipes ($s_1 \geq 0$ mm)
- Type of pipes: refer to 3.2.2.1; 3.2.2.2; 3.2.2.3, 3.2.2.4; 3.2.2.5; 3.2.2.8; 3.2.2.9; 3.2.2.10; 3.2.2.12
- Range of pipes: refer to 3.2.2.1; 3.2.2.2; 3.2.2.3, 3.2.2.4; 3.2.2.5; 3.2.2.8; 3.2.2.9; 3.2.2.10; 3.2.2.12 Excluded are only pipes with outside nominal diameter ($d_c > 110$ mm).

Flexible, elastomeric thermal insulation D_E :

- Type of material: refer to 3.1.13
- CS situation

Pipes in zero distance to CFS-C EL:

- see table below

Aluminum composite pipes EI60 U/C

Pipe Ø (mm)	Wall thickness (mm)	Pipe Insulation		
		Type	Thickness (mm)	Configuration (---)
Fränkische Rohrwerke - Alpex F50 Profi – material: PE-X/Al/PE-X				
16 - 40	2,0 - 3,5	elastomeric	8,0 - 36,5	CS
Geberit Mepla – material: PE-Xb/Al/PE-Xb				
16 - 40	2,0 - 3,5	elastomeric	8,0 - 36,5	CS
Viega - SANIFIX Fosta-Rohr – material: PE-Xc/Al/PE-Xc				
16 - 40	2,2 – 3,5	elastomeric	8,0 - 36,5	CS

Aluminum composite pipes and PP-R pipes EI90 U/C

Pipe Ø (mm)	Wall thickness (mm)	Pipe Insulation		
		Type	Thickness (mm)	Configuration (---)
Aquatherm green – material: PP-R – standard: EN 15874, DIN 8077/78				
20 - 110	1,9 - 10,0	elastomeric	8,0 - 40,5	CS
Fränkische Rohrwerke - Alpex F50 Profi – material: PE-X/Al/PE-X				
16	2,0	elastomeric	8,0 - 32	CS
16 - 32	2,0 - 3,0	elastomeric	8,0 - 9,0	CS
16 - 75	2,0 - 5,0	elastomeric	32,0 - 40,5	CS
Geberit Mepla – material: PE-Xb/Al/PE-Xb				
16 - 32	2,25 - 3,5	elastomeric	8,0 - 9,0	CS
16 - 75	2,25 - 4,75	elastomeric	32,0 - 40,5	CS
Georg Fischer - Sanipex – material: PE-Xc/Al/PE-Xb				
16 - 63	2,25 - 4,5	elastomeric	9,0 - 39	CS
Kekelit Kelox – material: PE-RT/Al/PE-RT				
16 - 75	2,0 - 7,0	elastomeric	8,0 - 40,5	CS
Kekelit Ketrax – material: Cryolen Polyolefinblend (POB) – standard: EN 15847				
20 - 75	1,9 - 6,8	elastomeric	8,0 - 40,5	CS
Polo-Polymutan – material: PP-R 80 – standard: DIN 8077/78				
20 - 75	1,9/6,8 - 12,5	elastomeric	8,0 - 40,5	CS

Polo-Polymutan ML5– material: PP-R				
20 - 75	2,8 - 10,8	elastomeric	8,0 - 40,5	CS
Prineto Stabil Rohr – material: PE-Xb/Al/PE-HD				
17 - 42	2,8 - 4,6	elastomeric	8,0 - 36,5	CS
17 - 63	2,8 - 6,0	elastomeric	32,0 - 39,0	CS
Rehau Rautitan Flex – material: PE-Xa – standard: EN 151875				
16 - 63	2,2 - 8,6	elastomeric	8,0 - 39	CS
Rehau Rautitan Stabil – material: PE-Xa				
40	6,0	elastomeric	9,0 - 38,5	CS
TECEflex Verbundrohr – material: PE-Xc/Al/PE				
16 - 63	2,2 – 6,0	elastomeric	9,0 - 39	CS
Uponor Unipipe Plus – material: PE-RT/Al/PE-RT				
16 - 32	2,0 – 3,0	elastomeric	8,0 – 35,0	CS
Viega - SANIFIX Fosta-Rohr – material: PE-Xc/Al/PE-Xc				
16 - 32	2,2 – 3,2	elastomeric	8,0 – 9,0	CS
16 - 63	2,2 – 4,5	elastomeric	32,0 - 39	CS
Viega Raxofix – material: PE-Xc/Al/PE-Xc				
16 - 32	2,2 – 3,2	elastomeric	8,0 - 33,0	CS

3.2.2.23.4 All pipes named in 3.2.2.1; 3.2.2.2; 3.2.2.4; 3.2.2.5; 3.2.2.8; 3.2.2.9; 3.2.2.10; 3.2.2.12 in flexible wall ($t_E \geq 100$ mm), pipe group 1, EI 90-U/U, Zero distance between CFS-C EL collar and CFS-B, wrapped around PE foamed insulation or PE protection tube on aluminium composite pipes

Situation for EI 90 - U/U:

- Zero distance between CFS-C EL collar and CFS-B, wrapped around PE foamed insulation or PE protection tube on aluminium composite pipes ($s_1 \geq 0$ mm)
- Type of pipes: refer to 3.2.2.1; 3.2.2.2; 3.2.2.3, 3.2.2.4; 3.2.2.5; 3.2.2.8; 3.2.2.9; 3.2.2.10; 3.2.2.12
- Range of pipes: refer to 3.2.2.1; 3.2.2.2; 3.2.2.3, 3.2.2.4; 3.2.2.5; 3.2.2.8; 3.2.2.9; 3.2.2.10; 3.2.2.12 Excluded are only pipes with outside nominal diameter ($d_c > 110$ mm).

Pipes in zero distance to CFS-C EL:

- see table below

Gap size and gap filling:

Gap filling in flexible wall application ($t_E \geq 100$ mm),:

- Gap filler: Hilti CFS-S ACR or gypsum
- Annular Gap: 0 – 15 mm
- Depth t_{A2} to be filled with Hilti CFS-S ACR or gypsum: ($t_{A2} \geq 25$ mm)
- No backfilling required

Gap filling in rigid wall application ($t_E \geq 100$ mm):

- Gap filler: Hilti CFS-S ACR
- Annular gap: 0 – 15 mm
- Depth t_{A2} to be filled with Hilti CFS-S ACR: ($t_{A2} \geq 25$ mm)
- No backfilling required
- or**
- Gap filler: cementious Mortar M10 acc. EN 998-2
- Annular gap: 0 – 40 mm
- Depth to be filled with cementious Mortar M10: to fill over entire wall thickness
- or**
- Gap filler: Hilti CFS-S ACR
- Annular gap: 0 – 40 mm
- Depth t_{A2} to be filled with Hilti CFS-S ACR: ($t_{A2} \geq 25$ mm)
- Back filled with mineral wool, refer to Annex 2, chapter 2.2

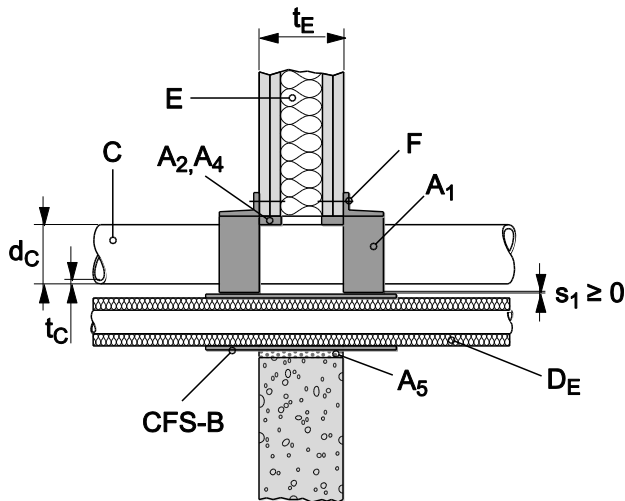

PE foamed insulation or PE protection tube on aluminium composite EI90 U/C

Pipe Ø (mm)	Wall thickness (mm)	Pipe Insulation		
		Type	Thickness (mm)	Configuration (mm)
Geberit Mepla – material: PE-Xb/Al/PE-Xb				
16 - 26	2,2 - 3,0	PE-foam	6,0 – 13,0	CS
Kekelit Kelox – material: PE-RT/Al/PE-RT				
14 - 32	2,0 - 3,0	PE-foam	4,0 – 9,0	CS
16 - 20	2,0 - 2,25	PE-HD tube		LS \geq 250
16 - 20	2,0 - 2,25	PE Foam+ PE-HD tube	4,0	CS
Uponor Unipipe MLC – material: PE-RT/Al/PE-RT				
16 - 20	2,0 - 2,25	PE-HD tube		LS \geq 250
Uponor Unipipe Plus – material: PE-RT/Al/PE-RT				
16 - 25	2,0 - 2,5	PE foam	4,0 -10,0	CS

3.2.2.24 All pipes named in 3.2.2.1; 3.2.2.2; 3.2.2.4; 3.2.2.5; 3.2.2.8; 3.2.2.9; 3.2.2.10; 3.2.2.12 in flexible wall ($t_E \geq 100$ mm), pipe group 1, EI 90 – U/U, CFS-C EL collar installed on plastic pipes, sealed by using the coated board CFS-CT B 1S

Situation for EI 90 - U/U (refer to 3.1.14):

- Plastic pipes, penetrating a wall seal made of mineral wool board, could be sealed with CFS-C EL
- Type of pipes: refer to 3.2.2.1; 3.2.2.2; 3.2.2.4; 3.2.2.5; 3.2.2.8; 3.2.2.9; 3.2.2.10; 3.2.2.12
- Range of pipes: refer to 3.2.2.1; 3.2.2.2; 3.2.2.4; 3.2.2.5; 3.2.2.8; 3.2.2.9; 3.2.2.10; 3.2.2.12

Excluded are only pipes with outside nominal diameter ($d_C > 110$ mm).

- Distance between the pipes penetrating the board is ($s_1 \geq 80$ mm)
- Pipes have to be grouped in line only
- The number of penetrating pipes in line is not limited.
- Pipes are allowed with zero distance to building element ($s_3 \geq 0$ mm)
- Gap seal around the board to building element is CFS-S ACR
- Gap seal around the pipes to board is CFS-S ACR
- For allowed boards refer to 3.1.14 and Annex 2, Chapter 2.2.

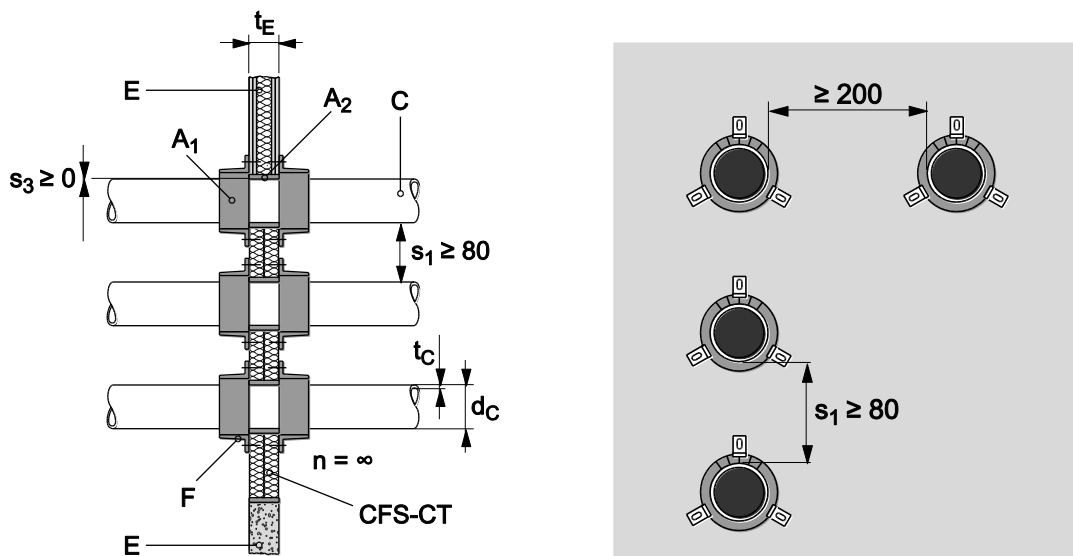

3.2.2.25 All pipes named in 3.2.2.1; 3.2.2.2; 3.2.2.4; 3.2.2.5; 3.2.2.8; 3.2.2.9; 3.2.2.10; 3.2.2.12 in flexible wall ($t_E \geq 100$ mm), pipe group 1, EI 90 - U/U, CFS-C EL collar to collar (zero distance)

Situation for EI 90 - U/U (refer to 3.1.9) :

- Zero distance between two CFS-C EL collars, sealing two plastic pipes ($s_1 \geq 0$ mm)
- Type of pipes: refer to 3.2.2.1; 3.2.2.2; 3.2.2.4; 3.2.2.5; 3.2.2.8; 3.2.2.9; 3.2.2.10; 3.2.2.12
- Range of pipes: refer to 3.2.2.1; 3.2.2.2; 3.2.2.4; 3.2.2.5; 3.2.2.8; 3.2.2.9; 3.2.2.10; 3.2.2.12

Excluded are only pipes with outside nominal diameter ($d_c > 110$ mm)

- Pipes have to be group in line
- Number of pipes in line is unlimited

3.2.2.26 PP pipes acc. EN 1451-1 and DIN 8077/78, in flexible and rigid wall ($t_E \geq 100$ mm) pipe group 1, EI 120 - U/U, Pipe coupling

Situation for EI 120 - U/U:

- Pipe coupling inside the wall, half in the wall or outside the wall, covered by CFS-C EL
- Type of pipes: PP pipes acc. EN 1451-1
- Range of pipes :

Pipe Range:

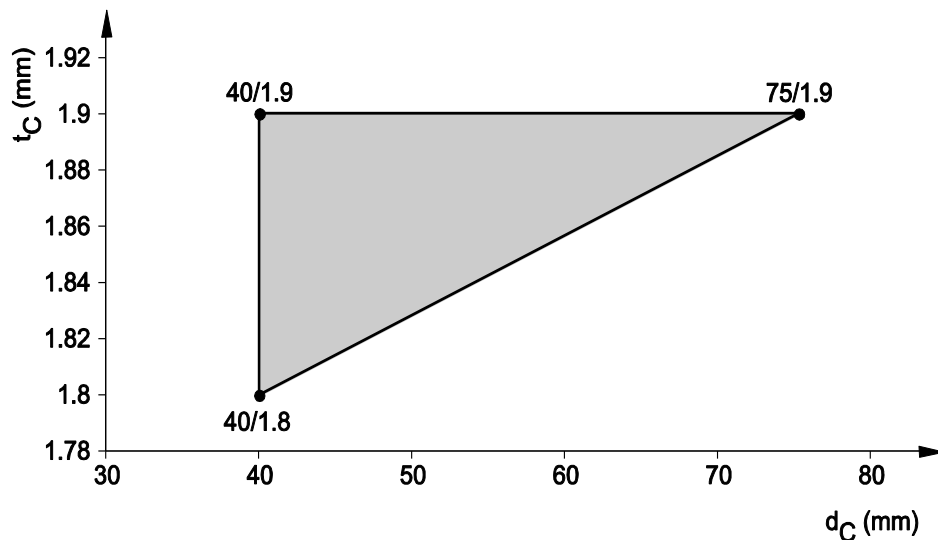

- Pipe insulation: see 3.1.6

Gap size and gap filler:

In flexible wall application ($t_E \geq 100$ mm):

- Gap filler: Hilti CFS-S ACR or gypsum
- Annular gap: 0 – 15 mm
- Depth t_{A2} to be filled with Hilti CFS-S ACR or gypsum: ($t_{A2} \geq 25$ mm)
- No backfilling required

In rigid wall application ($t_E \geq 100$ mm):

- Gap filler: Hilti CFS-S ACR
 - Annular gap: 0 – 15 mm
 - Depth t_{A2} to be filled with Hilti CFS-S ACR: ($t_{A2} \geq 25$ mm)
 - No backfilling required
- or**
- Gap filler: cementious Mortar M10 acc. EN 998-2
 - Annular gap: 0 – 40 mm
 - Depth to be filled with cementious Mortar M10: to fill over entire wall thickness
- or**

- Gap filler: Hilti CFS-S ACR
- Annular gap: 0 – 40 mm
- Depth t_{A2} to be filled with Hilti CFS-S ACR: ($t_{A2} \geq 25$ mm)
- Back filled with mineral wool, refer to Annex 2, chapter 2.2
-

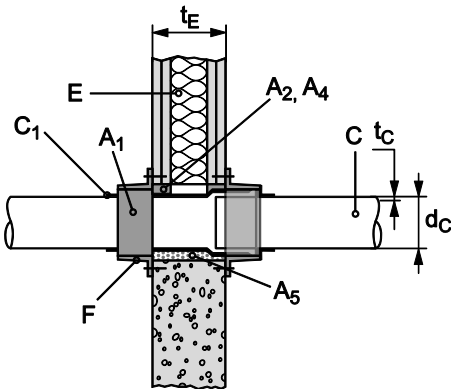

Requested number of hooks:

Pipe outside nominal diameter d_c (mm)	Acoustic Pipe Insulation Thickness t_D (mm) (incoming pipe / outgoing pipe)		
	0	4	9
40	2 / 2	2 / 2	2 / 2
41 -75	3 / 3	3 / 3	3 / 3

If pipe insulation thickness is between 0 and 4mm use the number of hooks indicated for 4 mm. If pipe insulation thickness is between 4 and 9 mm use the number of hooks indicated for 9 mm.

**3.2.2.27 PVC – pipes acc. EN 1452-1, EN 1329-1, EN 1453-1, EN 1566-1; DIN 8061/62, EN ISO 15493, in flexible and rigid wall ($t_E \geq 100$ mm)
pipe group 1, EI 120 - U/U, Pipe Elbow 87°**

Situation for EI 120 - U/U:

- 87° Elbow, Elbow partly or completely inside the wall, covered by CFS-C EL
- Range of pipes:

Pipe Range:

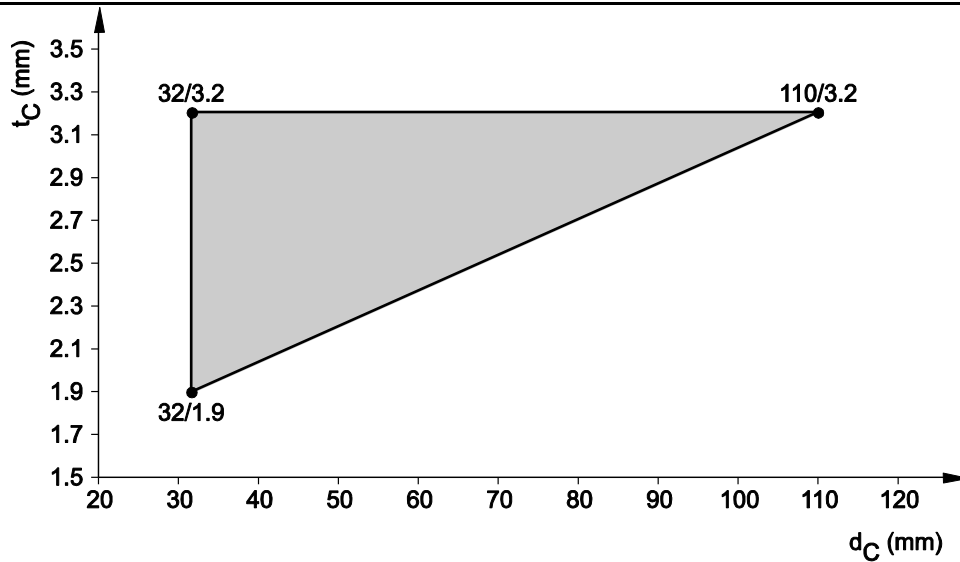

- On one side of the wall pipe runs parallel to wall with zero distance ($s_3 \geq 0$ mm).

Gap size and gap filler:

In flexible and massive wall application ($t_E \geq 100$ mm),:

- Gap filler: Hilti CFS-FIL
- Annular gap: 5 – 40 mm
- Depth t_{A2} to be filled with Hilti CFS-FIL: ($t_{A2} \geq 25$ mm)
- No backfilling required

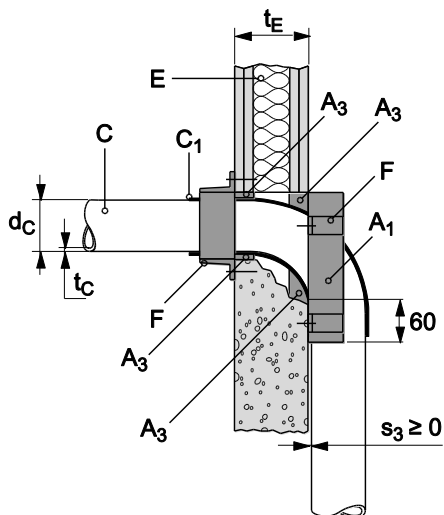

Requested number of hooks:.

Pipe outside nominal diameter d_C (mm)	Acoustic Pipe Insulation Thickness t_D (mm) (no elbow side - horizontal running pipe / elbow side - vertical running pipe)		
	0	4	9
32 - 109	3 / 3	3 / 3	3 / 3
110	4 / 4	4 / 4	4 / 4

If pipe insulation thickness is between 0 and 4mm use the number of hooks indicated for 4 mm. If pipe insulation thickness is between 4 and 9 mm use the number of hooks indicated for 9 mm.

3.2.2.28 PP – pipes acc. EN 1451-1 and DIN 8077/78, in flexible and rigid wall ($t_E \geq 100$ mm) pipe group 1, EI 90 - U/U, Pipe Elbow 87°

Situation for EI 90 - U/U:

- 87° Elbow Pipes, Elbow partly or completely inside the wall, covered by CFS-C EL
- Range of pipes : see below

Pipe Range:

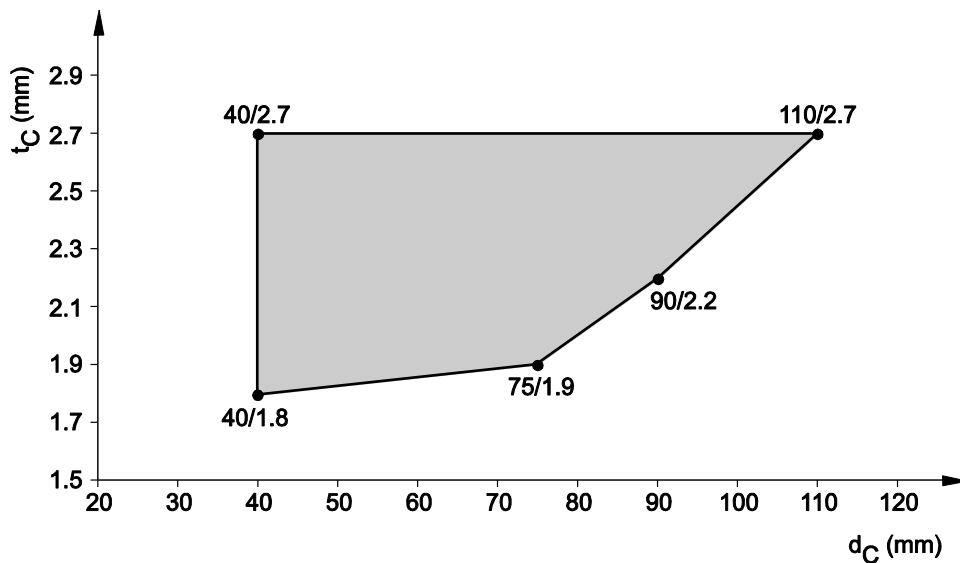

- On one side of the wall pipe runs parallel to wall with zero distance ($s_3 \geq 0$ mm).

Gap size and gap filler:

In flexible wall application ($t_E \geq 100$ mm),:

- Gap filler: Hilti CFS-S ACR or gypsum
- Annular gap: 0 – 15 mm
- Depth t_{A2} to be filled with Hilti CFS-S ACR or gypsum: ($t_{A2} \geq 25$ mm)
- No backfilling required

In rigid wall application ($t_E \geq 100$ mm),:

- Gap filler: Hilti CFS-S ACR
- Annular gap: 0 – 15 mm
- Depth t_{A2} to be filled with Hilti CFS-S ACR: ($t_{A2} \geq 25$ mm)
- No backfilling required
- **or**
- Gap filler: Hilti CFS-S ACR
- Annular gap: 0 – 40 mm
- Depth t_{A2} to be filled with Hilti CFS-S ACR: ($t_{A2} \geq 25$ mm)
- Back filled with mineral wool, refer to Annex 2, chapter 2.2
- **or**
- Gap filler: cementitious Mortar M10 acc. EN 998-2
- Annular gap: 0 – 40 mm
- Depth to be filled with cementitious Mortar M10: to fill over entire wall thickness

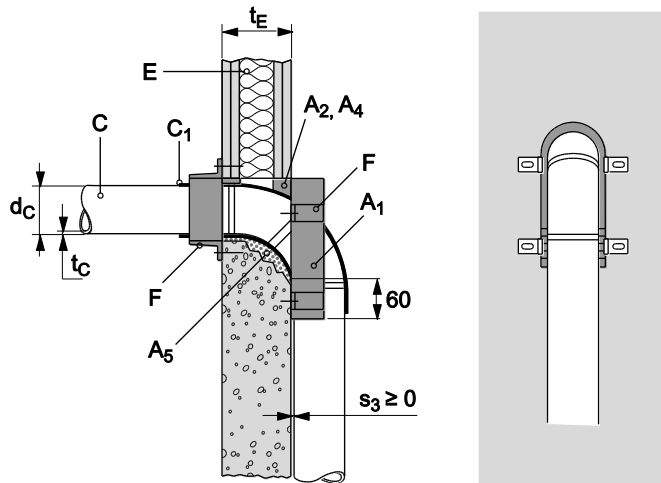

Requested number of hooks:

Pipe outside nominal diameter d_C (mm)	Acoustic Pipe Insulation Thickness t_D (mm) (no elbow side - horizontal running pipe / elbow side - vertical running pipe)		
	0	4	9
40 - 74	3 / 3	3 / 3	3 / 3
75 - 109	3 / 3	3 / 3	3 / 3
110	3 / 4 (on Elbow side)	3 / 4 (on Elbow side)	3 / 4 (on Elbow side)

If pipe insulation thickness is between 0 and 4mm use the number of hooks indicated for 4 mm. If pipe insulation thickness is between 4 and 9 mm use the number of hooks indicated for 9 mm.

3.3 Rigid walls

3.3.1 Specific characteristics for Rigid walls ($t_E > 100 \text{ mm}$)

3.3.1.1 Rigid walls:

The wall must have a minimum thickness of ($t_E \geq 100 \text{ mm}$) and minimum density of ($\rho_E \geq 650 \text{ kg/m}^3$) and comprise concrete, aerated concrete, brickwork, lime malm bricks or masonry.

3.3.1.2 Annular gap filled with:

Annular gap around penetrating item has to be filled with:

- Cementitious mortar acc. EN 998-2 group M10 over the entire thickness of the wall or
- Hilti Firestop Acrylic Sealant CFS-S ACR (A_2) on both sides with a depth of minimum ($t_{A2} \geq 25 \text{ mm}$) from the surface of the wall, backfilled with mineral wool or
- Hilti Firestop Acrylic Sealant CFS-S ACR (A_2) only with a depth of ($t_{A2} \geq 25 \text{ mm}$) from the surface of the wall

Annular gap width should be:

- 0 – 40 mm (when sealed with mortar group M10 acc. EN 998-2 over the entire wall thickness)
- 0 – 40 mm (when sealed with Hilti Firestop Acrylic Sealant CFS-S ACR and mineral wool backfilling)
- 0 – 15 mm (when sealed with Hilti Firestop Acrylic Sealant CFS-S ACR only)

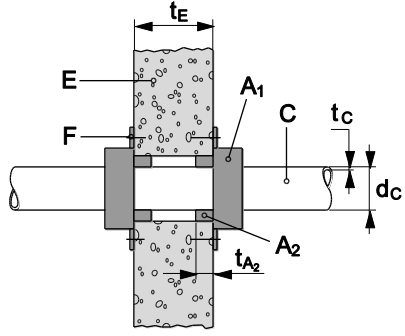
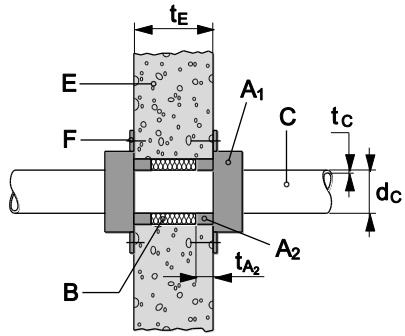
<p>Plastic pipe, penetrating a rigid wall, sealed with Hilti Firestop Collar CFS-C EL. Used gap filler is CFS-S ACR only. Pipes are approved with and without sound decoupling insulation.</p>	
<p>Plastic pipe, penetrating a rigid wall, sealed with Hilti Firestop Collar CFS-C EL. Used gap filler is CFS-S ACR with mineral wool backing. Pipes are approved with and without sound decoupling insulation.</p>	

Plastic pipe, penetrating a rigid wall, sealed with Hilti Firestop Collar CFS-C EL. Used gap filler is mortar group M10 acc. EN 998-2 over the entire wall thickness. Pipes are approved with and without sound decoupling insulation.

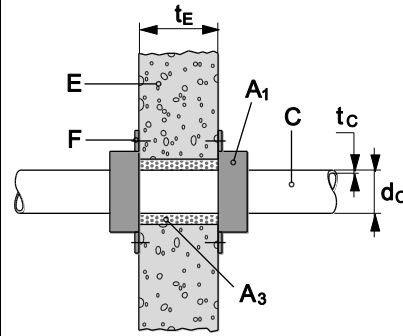

3.3.1.3 Collar fixing

Hilti Firestop Collar Endless CFS-C EL (A_1) to be fixed with hooks (F) on the wall. The required number and type of hooks is shown in Tab.2.

Hooks fixing in rigid walls is described in 3.1.4 and Tab.3.

Bent hooks could be pressed into the wet gap seal, made of cementitious mortar. For details regarding Integrity and insulation in pipe group 1 and pipe group 2 refer to 3.3.3.12.

3.3.2 Penetration services rigid walls ($t_E \geq 100$ mm)

3.3.2.1 PE pipes acc. EN 1519-1, EN 12666-1, EN 12201-2, ABS-pipes acc. EN 1455-1 and SAN+ PVC pipes acc. EN 1565-1 in flexible wall and rigid wall ($t_E \geq 100$ mm), pipe group 1, EI 120 - U/U

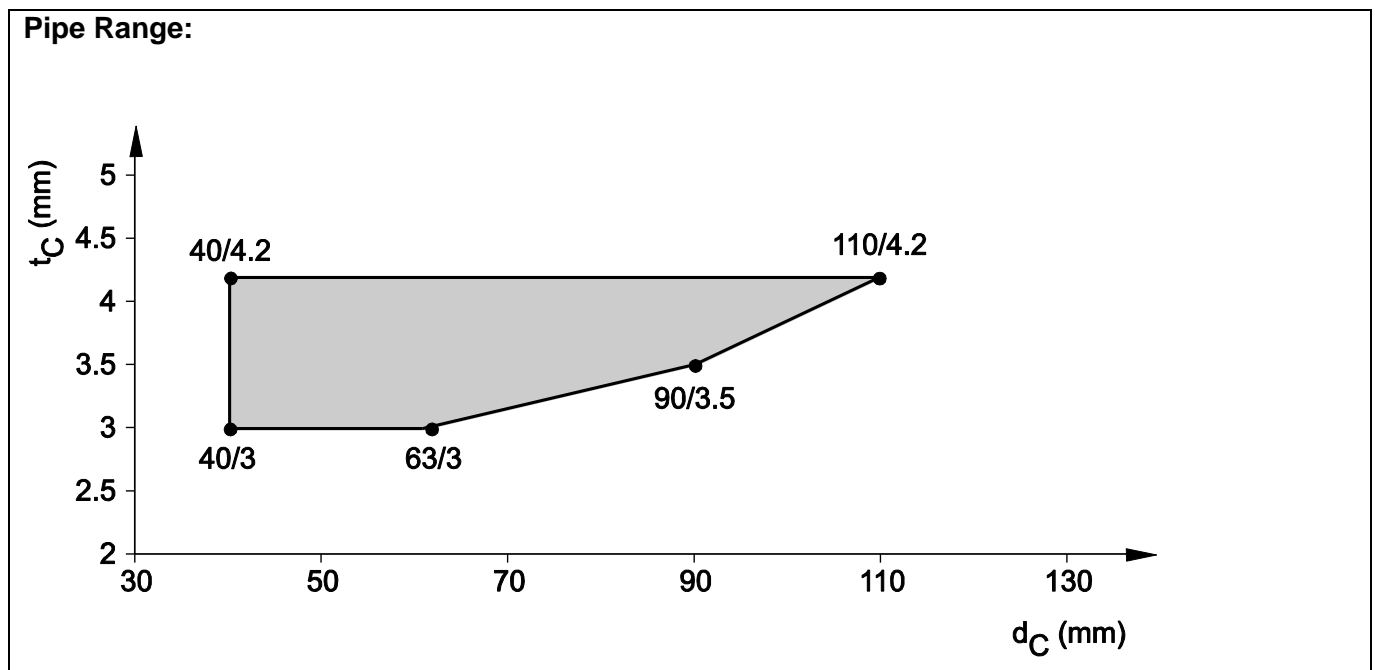

**3.3.2.2 PE pipes acc. EN15494, EN 12201-2 and DIN 8074/75,
in flexible wall and rigid wall ($t_E \geq 100$ mm), pipe group 1, EI 120, U/U**

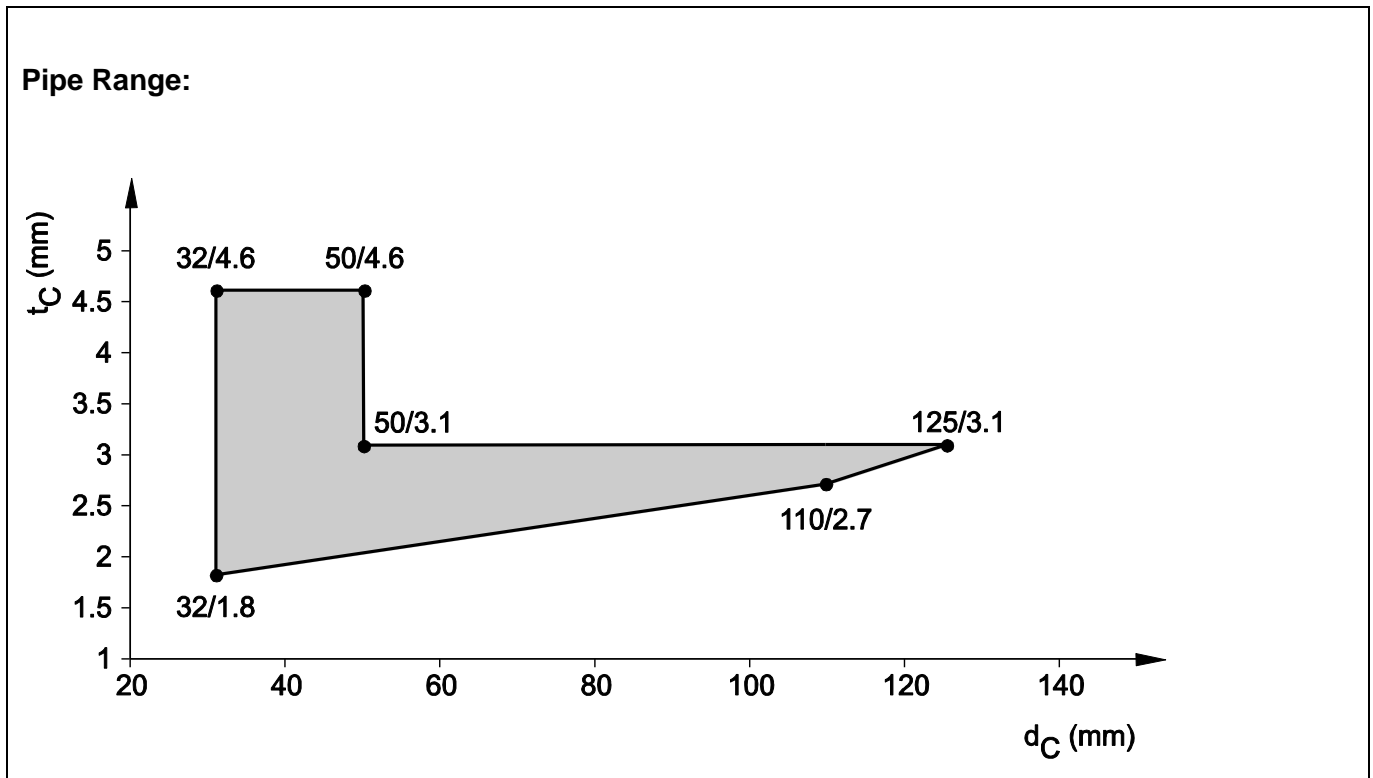

**3.3.2.3 PE pipes acc. EN15494, EN 12201-2 and and DIN 8074/75,
in flexible wall and rigid wall ($t_E \geq 100$ mm), pipe group 1, EI 120 - U/C**

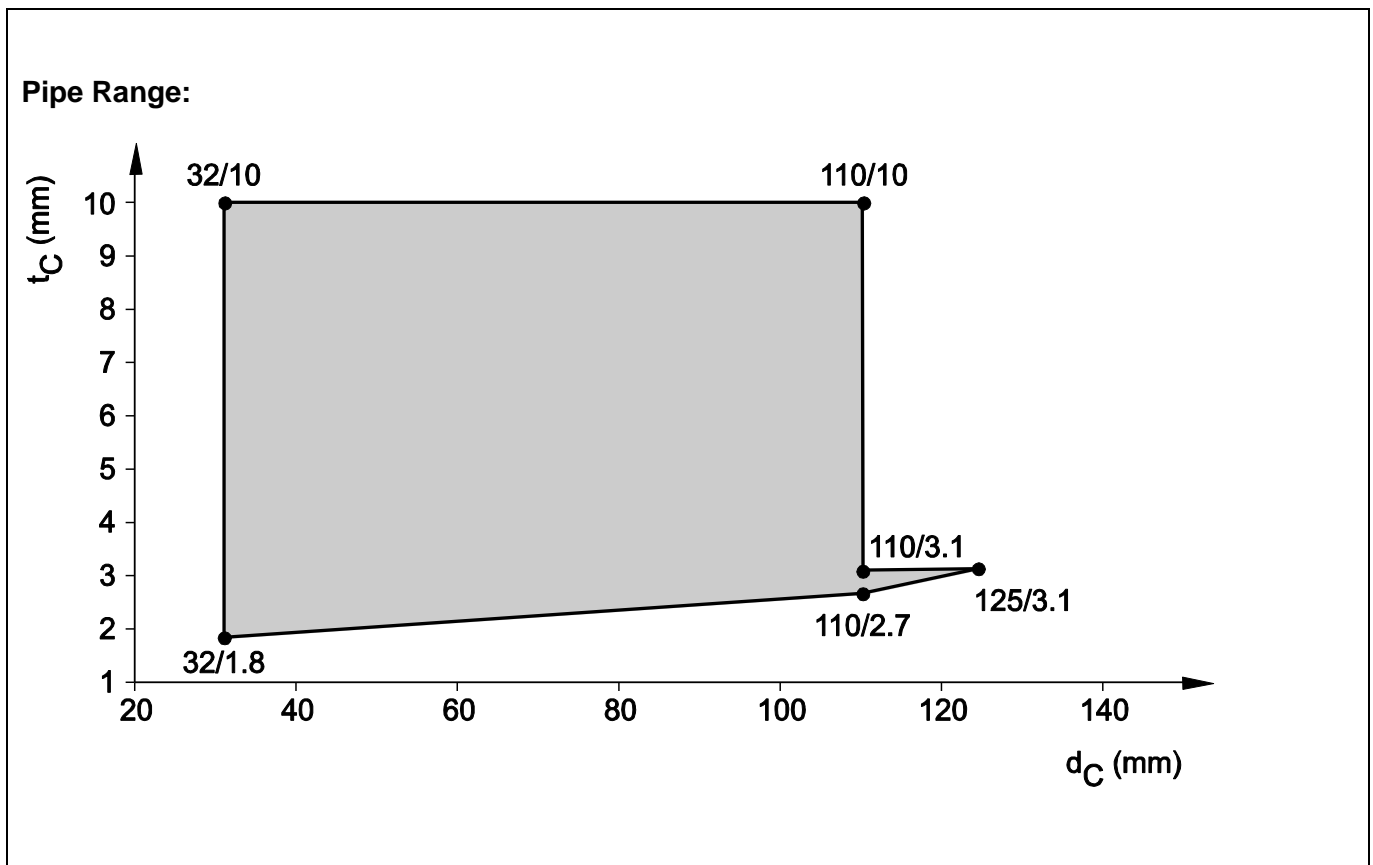

**3.3.2.4 PVC pipes acc. EN 1452-1, EN 1329-1, EN 1453-1, EN1566-1, EN ISO 15493
and DIN 8061/62 in flexible wall and rigid wall ($t_E \geq 100$ mm),
pipe group 1, EI 120 - U/U**

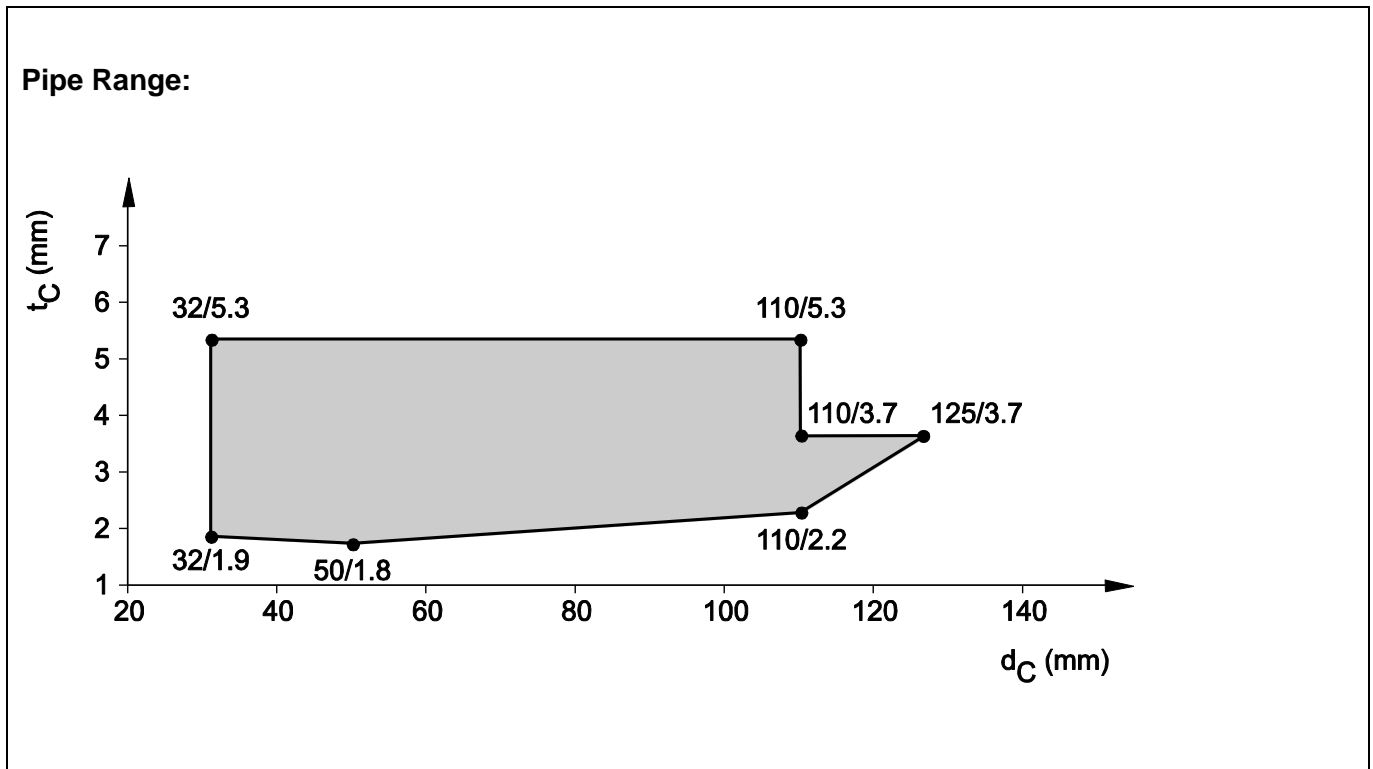

**3.3.2.5 PP pipes, non-regulated in flexible wall and rigid wall ($t_E \geq 100$ mm),
pipe group 1, EI 120 - U/U**

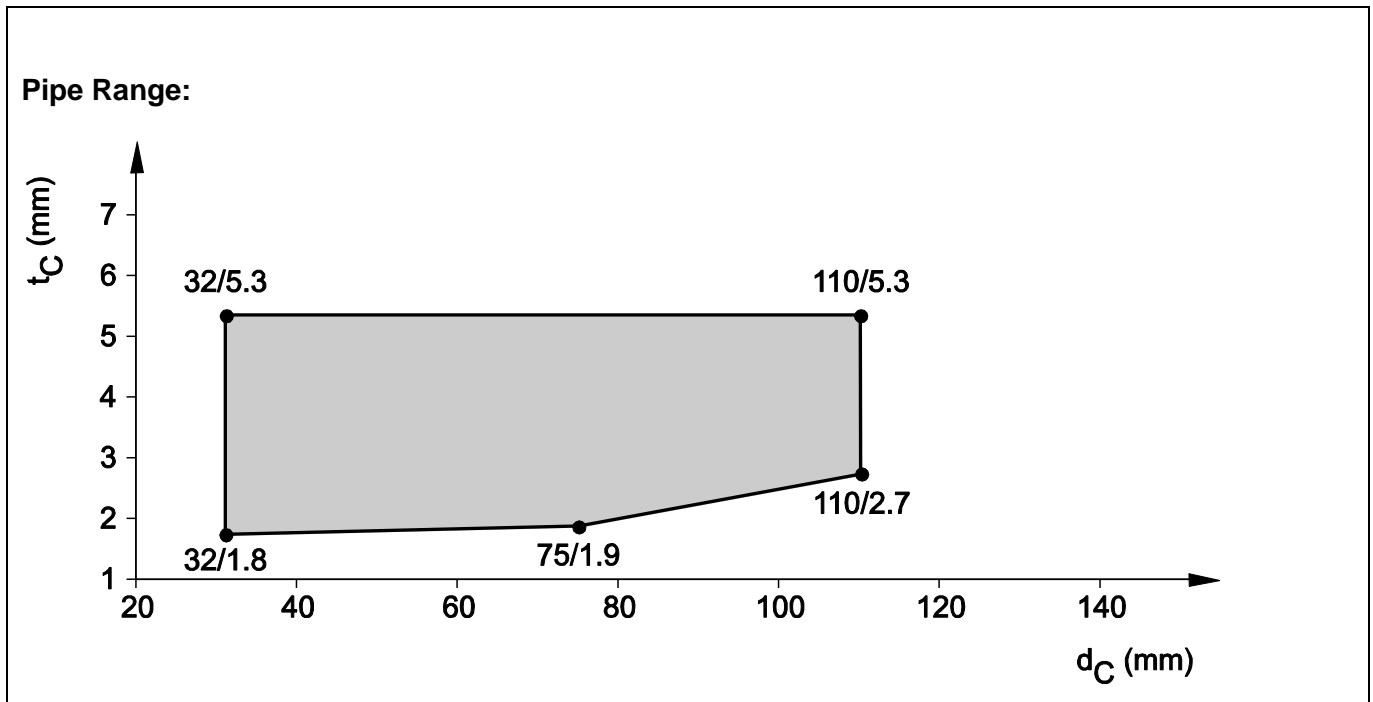

Approved manufactures / pipe types: refer to 3.1.15

3.3.2.6 PP pipes acc. EN1451-1 and DIN 8077/78,
in flexible wall and rigid wall ($t_E \geq 100$ mm), pipe group 1, EI 120 - U/U

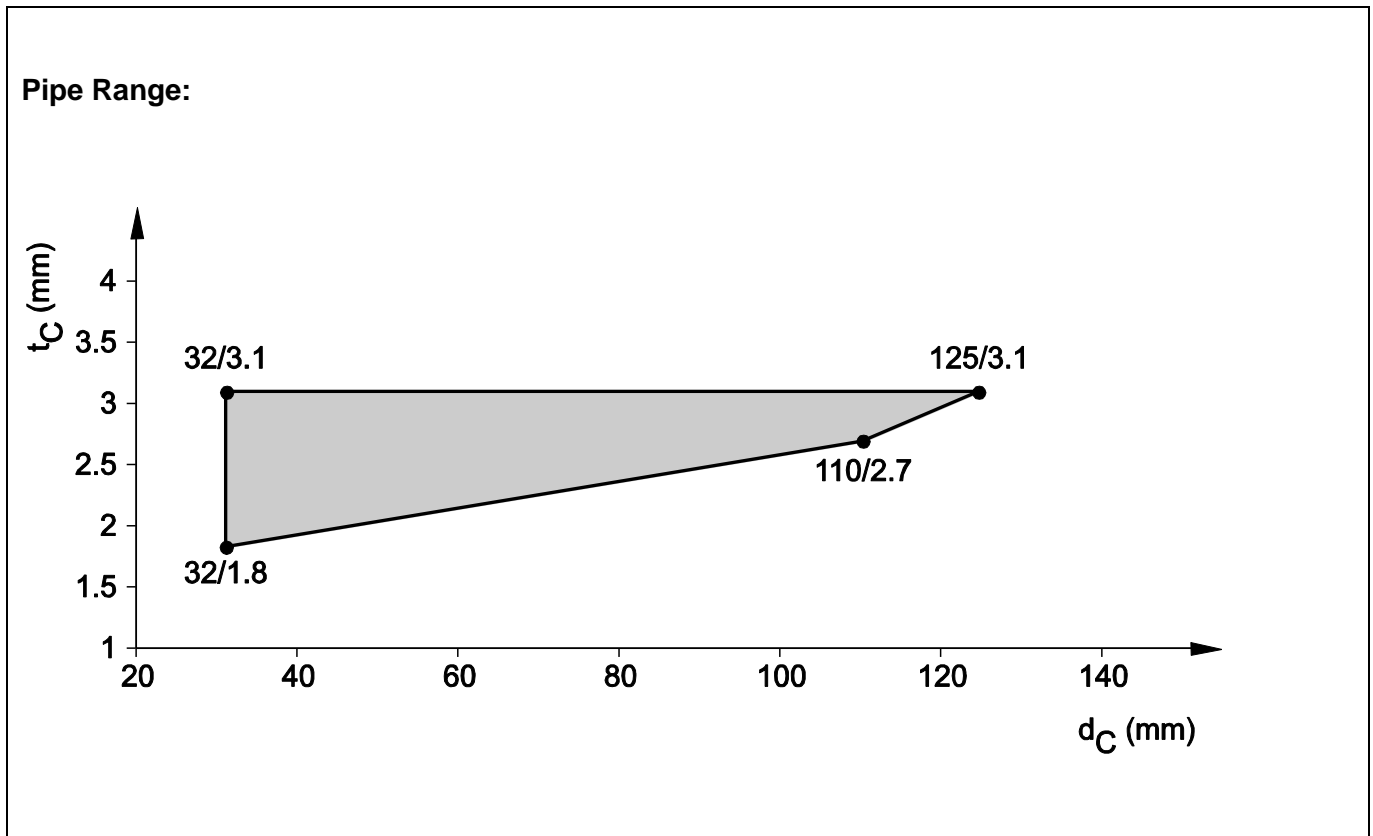

3.3.2.7 PP pipes acc. EN1451-1 and DIN 8077/78,
in flexible wall and rigid wall ($t_E \geq 100$ mm), pipe group 1, EI 120 - U/C

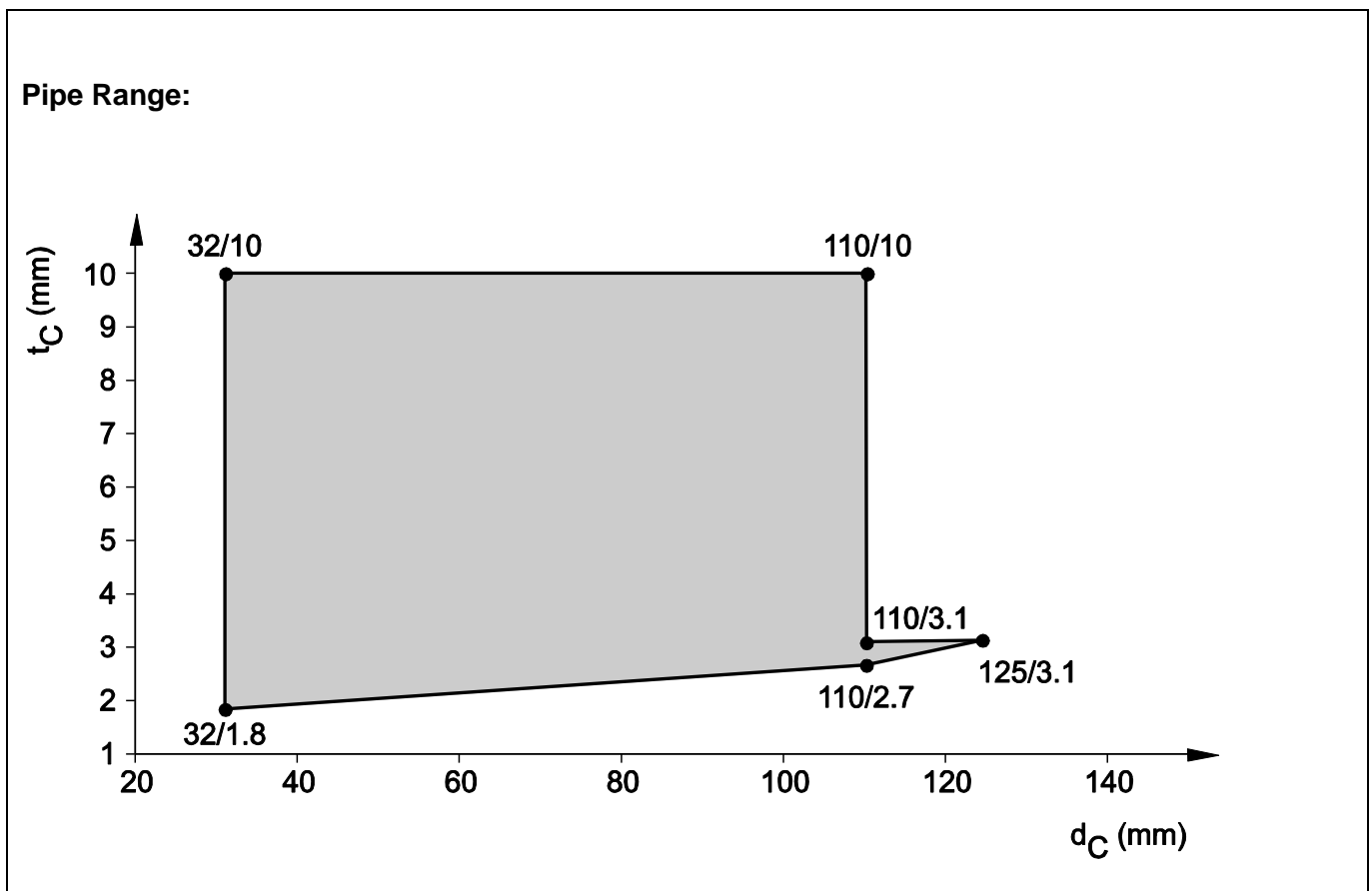

3.3.2.8 Not defined

3.3.2.9 All pipes named in 3.3.2.1; 3.3.2.2; 3.3.2.4; 3.3.2.5; 3.3.2.6; 3.2.2.12 in rigid wall ($t_E \geq 100$ mm), pipe group 1, EI 120 - U/U, Pipes directly mounted on the wall - zero distance pipe to wall

All pipes named in 3.3.2.1; 3.3.2.2; 3.3.2.4; 3.3.2.5; 3.3.2.6; 3.2.2.12 may be used in a *Pipe on the wall* application when penetrating a rigid wall thickness ($t_E \geq 100$ mm) with an EI120 - U/U classification.

Excluded from approved pipe range are pipes with outside nominal diameter ($d_c > 110$ mm).

Only pipes in pipe group 1 (refer to 3.1.2) are approved in this situation.

The pipes run with zero distance directly on wall ($s_3 \geq 0$ mm) before penetrating a wall.

Collar CFS-C EL cannot completely cover the circumference of sealed pipe.

Pictures below show view from above for pipe-on-the-wall application.

For number of hooks refer to 3.1.4 and Tab.3.

For fixing the hooks refer to 3.1.3.

view from above:

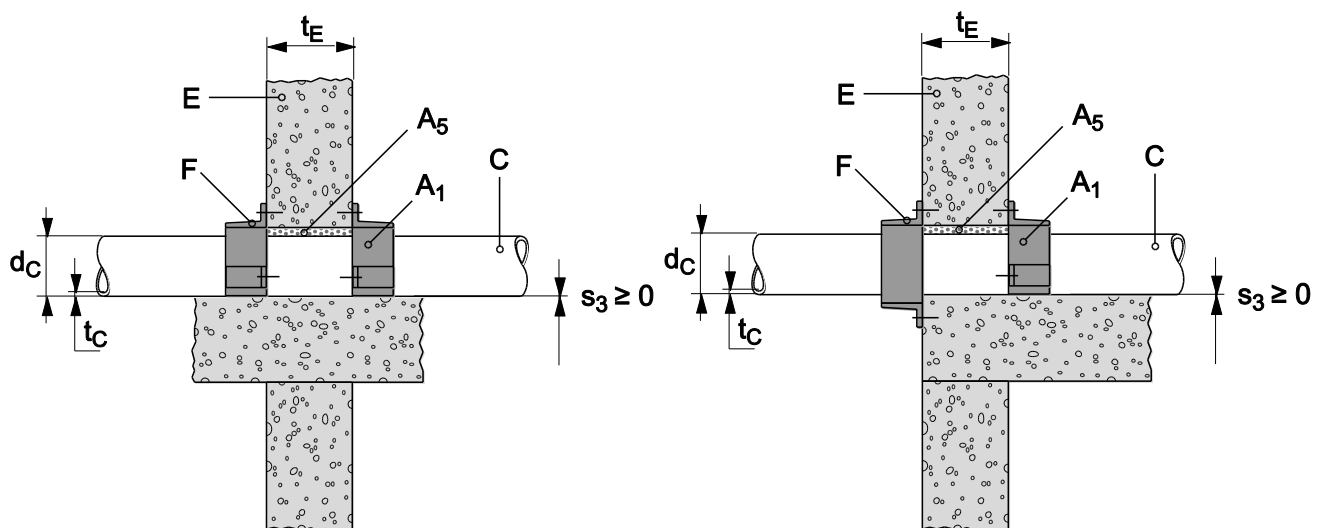

3.3.2.10 Multiple pipe penetration, covered with foamed elastomeric thermal insulation in rigid wall ($t_E \geq 100$ mm), pipe group 1, EI 120, U/U + U/C,

Situation for multiple pipes for EI 120 classification:

- One PE pipe acc. EN 1519-1, EN 12666-1, EN 12201-2 (U/U) in zero contact ($0 \text{ mm} \leq s_1 \leq 15 \text{ mm}$) together with
- One or two pipes acc. EN 15874 or EN 15875 (pipe material PP-R or PE-X) (U/C)
- The pipes acc. EN 15874 or EN 15875 are insulated with an elastomeric foamed thermal insulation
- Collar CFS-C EL covers the two or three pipes together within one bigger jacket.

PE pipe acc. EN 1519-1, EN 12666-1, EN 12201-2 (U/U):

- Pipe outside diameter is ($40 \text{ mm} \leq d_c \leq 90 \text{ mm}$)
- Pipe wall thickness thickness ($t_c = 3,5 \text{ mm}$)
- With or without sound decoupling isolation (for type, thickness and situation refer to 3.1.6)

PP-R or PE-X pipes acc. EN 15874 and EN 15875 (U/C):

- Pipe outside diameter is ($d_c = 40 \text{ mm}$)
- Pipe wall thickness thickness ($t_c = 5,5 \text{ mm}$)
- Type of pipes: Aquatherm fusiolen (aquatherm green pipe S) and Rehau Rautitan flex

Elastomeric foamed thermal insulation:

- For material type refer to 3.1.13
- Approved insulation thickness is ($9 \text{ mm} \leq t_D \leq 32$) mm
- Approved installation situation is LS and CS
- Minimum insulation length ($L_D \geq 250 \text{ mm}$) on both sides of the wall

Collar fixing:

- For number of hooks refer to 3.1.4 and Tab.3, for fixing the hooks refer to 3.1.3.

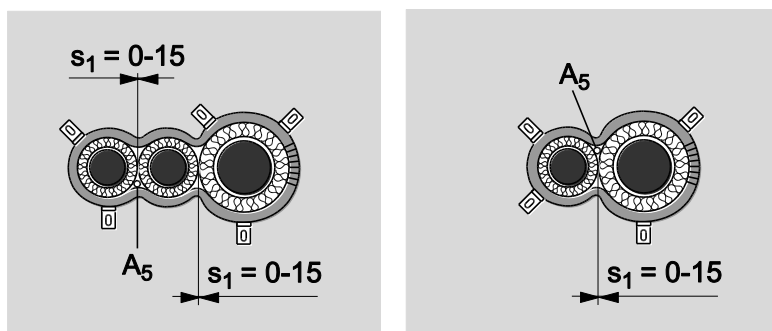

**3.3.2.11 Multiple pipe penetration, covered with foamed elastomeric thermal insulation ;
in rigid wall ($t_E \geq 100$ mm), pipe group 1, EI 120 - U/C,
zero distance to floor basement**

Situation for multiple pipes for EI 120 – U/C classification:

- One pipe or two pipes are mounted directly on the floor ($s_3 \geq 0$ mm)
- Pipes are located side by side ($s_1 \geq 0$ mm)
- Collar CFS-C EL cannot cover both pipes completely

Pipes :

- PP-R or PE-X pipes acc. EN 15874 and EN 15875 (U/C):
- Type of pipes: Aquatherm fusiolen (aquatherm green pipe S) and Rehau Rautitan flex
- Pipe outside diameter is ($d_c = 40$ mm)
- Pipe wall thickness thickness ($t_c = 5,5$ mm)

Elastomeric foamed thermal insulation:

- For material type refer to 3.1.13
- Insulation thickness is ($t_D = 25$ mm)
- Installation situation is LS and CS
- Minimum insulation length ($L_D \geq 250$ mm) on both sides of the wall

Collar fixing:

- For number of hooks refer to 3.1.4 and Tab.3, for fixing the hooks refer to 3.1.3.

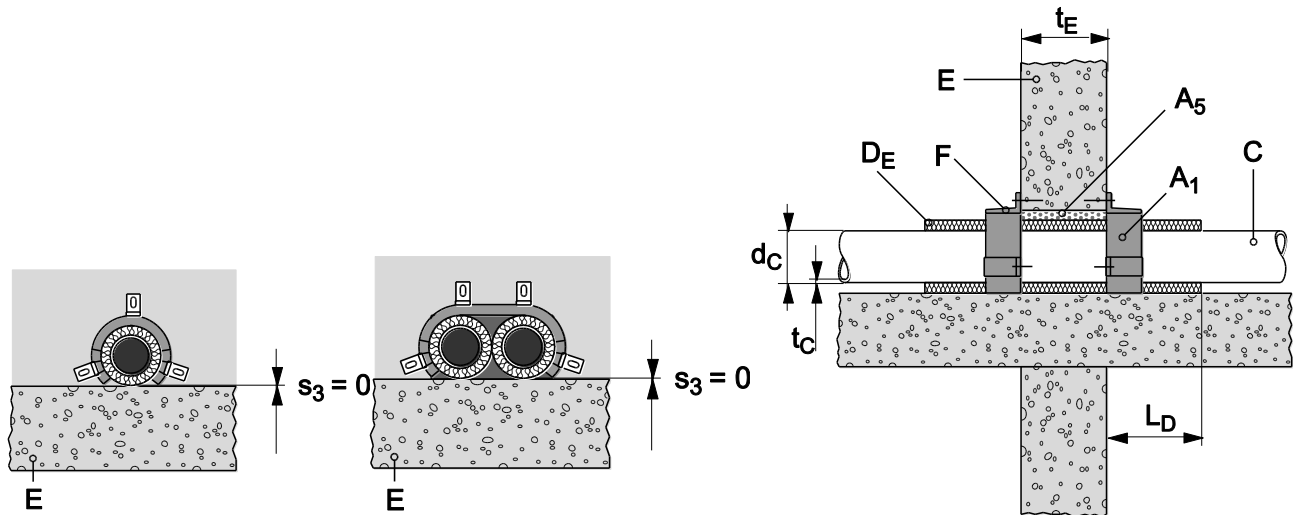

**3.3.2.12 Roof drainage, covered with foamed elastomeric thermal insulation ;
in rigid wall ($t_E \geq 100$ mm), pipe group 1, EI 120 - U/U,**

Situation for roof drainage for EI120 – U/U :

- One PE-pipe (U/U) insulated with elastomeric foamed insulation, sealed with CFS-C EL
- Pipe penetrates the wall in perpendicular and inclined (45°) situation
- Any pipe inclination in between 45° and 90°

Pipe :

- Material : see table below
- Pipe outside diameter see table below
- Pipe wall thickness see table below

Elastomeric foamed thermal insulation:

- For material type refer to 3.1.13
- Insulation thickness : see table below
- Installation situation is LS and CS
- Minimum insulation length ($L_D \geq 250$ mm) on both sides of the wall

Gap size and Gap filler:

- Gap size is 5 mm to 40 mm
- Gap filler is CFS-FIL
- Installation depth: ($t_{A3} \geq 25$ mm) on each side of the wall

Collar fixing in pipe group 1 and 2:

- For perpendicular situation (90°): refer to 3.1.4 and Tab.3 , for hook fixing refer to 3.1.3 and Tab.2

Rigid walls ($t_E \geq 100$ mm)			
Pipe material	PE	PE	PP
Norm/standard/ Producer/product	EN 1519-1, EN12666-1, EN 12201-2	Non-regulated, Geberit Silent dB20	Non-regulated, See 3.1.15
pipe diameter d_c	($40 \leq d_c \leq 110$ mm)	($40 \leq d_c \leq 110$ mm)	-
wall thickness t_c	($t_c = 4,2$ mm)	($t_c = 6,0$ mm)	-
insulation thickness t_D	($t_D = 19$ mm)	($t_D = 19$ mm)	-
Classification	EI 120	EI 120	-

Rigid walls ($t_E \geq 150$ mm)			
Pipe material	PE	PE	PP
Norm/standard/ Producer/product	EN 1519-1, EN12666-1, EN 12201-2	Non-regulated, Geberit Silent dB20	Non-regulated, See 3.1.15
pipe diameter d_c Pipe wall thickness t_c	See graphic 3.3.2.12 A and range given above for Rigid walls ($t_E \geq 100$ mm)	See graphic 3.3.2.12 B and range given above for Rigid walls ($t_E \geq 100$ mm)	See graphic 3.3.2.12 C and 3.3.2.12 D
Pipe wall thickness t_c	See graphic	See graphic	See graphic 3.3.2.12 C and 3.3.2.12 D

	3.3.2.12 A and range given above for Rigid walls ($t_E \geq 100$ mm)	3.3.2.12 B and range given above for Rigid walls ($t_E \geq 100$ mm)	
insulation thickness t_D	($t_D = 19$ mm)	($t_D = 19$ mm)	($t_D = 19$ mm)
Classification	EI 90	EI 120	EI 90

Gap size and Gap filler:

- Gap size is 5 mm to 40 mm
- Gap filler is CFS-FIL
- Installation depth: ($t_{A3} \geq 25$ mm) on each side of the wall

Collar fixing in pipe group 1 and 2:

- For perpendicular situation (90°): refer to 3.1.4 and Tab.3 , for hook fixing refer to 3.1.3 and Tab.2

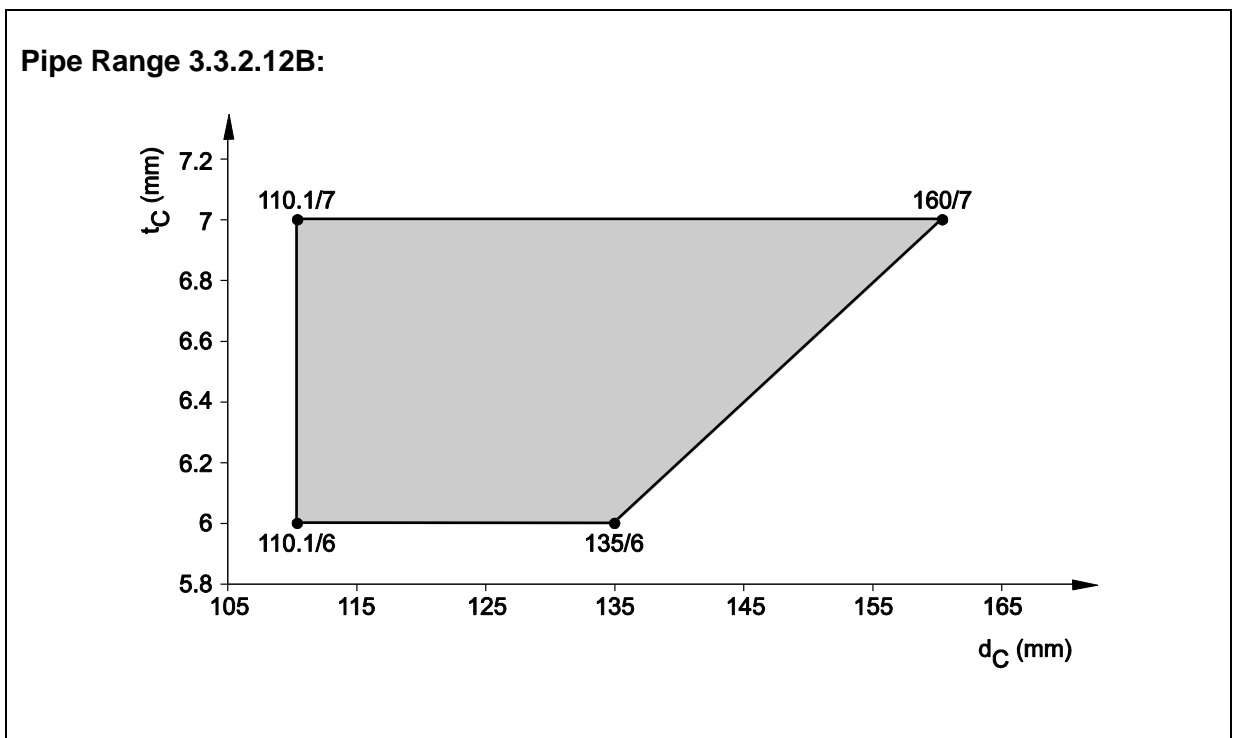
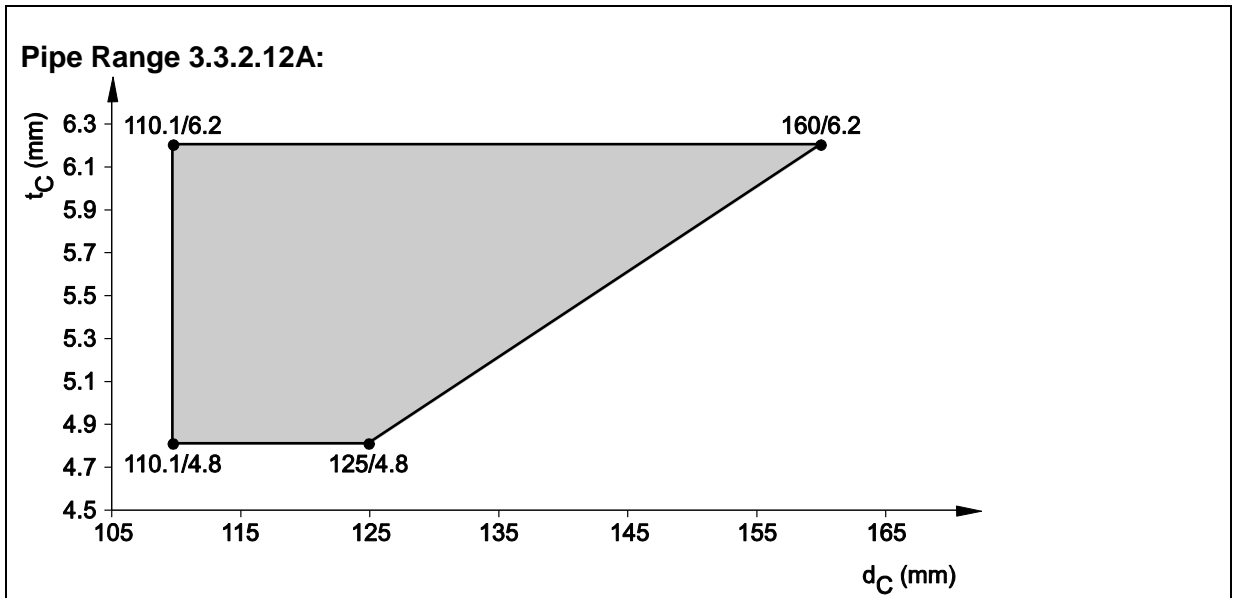

Pipe Range 3.3.2.12C:

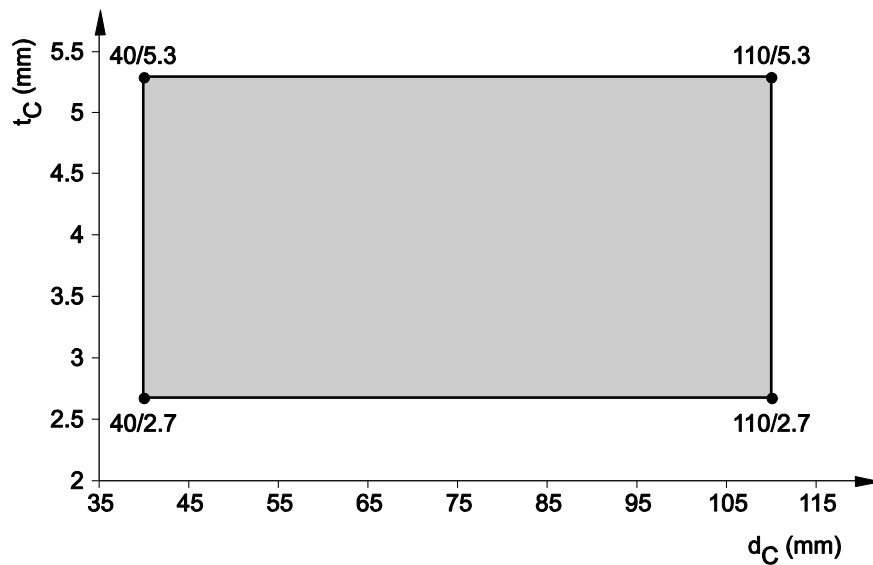

Pipe Range 3.3.2.12D:

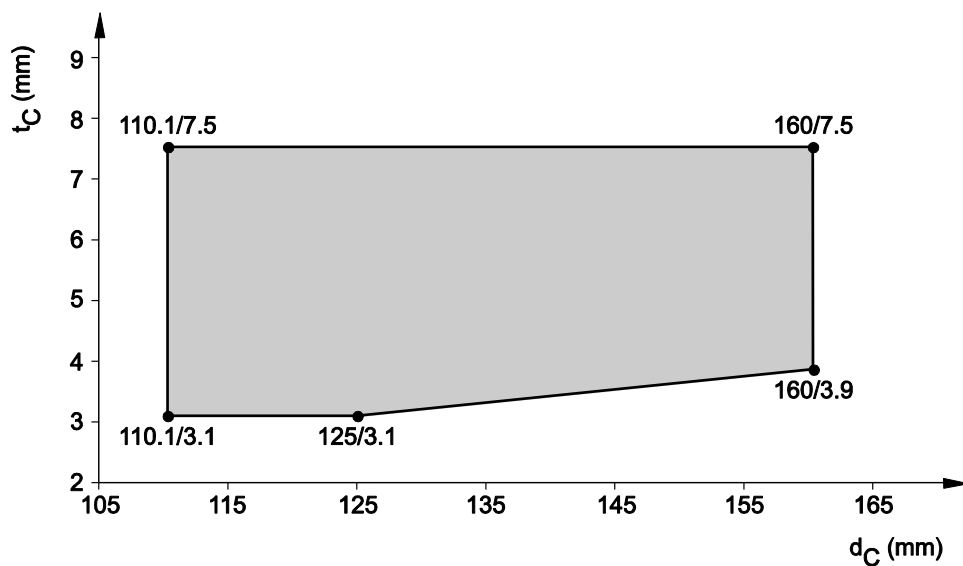

3.3.2.13 PE pipe with coupling or 2x45° elbow and electro welding coupler

**3.3.2.13A PE pipes , non-regulated (Geberit Silent dB20) , in rigid wall ($t_E \geq 100$ mm),
pipe group 1, EI 120 - U/U, specific application: 2x45° elbow connector**

Situation for EI 120 – U/U :

- Pipe elbow connector (2 pieces a 45° each), within or partly within the wall, covered by Collar CFS-C EL
- On one side of the wall pipe runs parallel to wall ($s_3 \geq 0$ mm)

Pipe :

- Material PE , type of pipe: Geberit Silent dB20

- Elbow connector 45°: Geberit Silent dB20 based on PE, electro-welding wire inside
- Pipe outside diameter is ($d_c = 110$ mm)
- Pipe wall thickness ($t_c = 6$ mm)

Gap size and Gap filler for elbow connector 2 x 45° only: :

- Gap size is 5 mm to 40 mm
- Gap filler is CFS-FIL
- Installation depth: $t_{A3} \geq 25$ mm on each side of the wall
- Backfilling with mineral wool, refer to Annex 2, chapter 2.2

Collar fixing:

- For number of hooks refer to 3.3.2.17

3.3.2.13B PE pipes, non-regulated (Geberit Silent dB20), in rigid wall ($t_E \geq 100$ mm), pipe group 1, EI 30 - U/U, specific application: pipe coupling

Situation for EI 30 – U/U:

- pipe coupling within or partly within the wall, covered by Collar CFS-C EL

Pipe :

- Material PE, type of pipe: Geberit Silent dB20
- Pipe coupling device: Geberit Silent dB20 based on PE, electro-welding wire inside
- Pipe outside diameter is ($d_c = 110$ mm)
- Pipe wall thickness ($t_c = 6$ mm)

Gap size and Gap filler for pipe coupling :

With CFS-S ACR:

- Gap size is 0 mm to 15 mm
- Gap filler is CFS-S ACR
- Installation depth: ($t_{A2} > 25$ mm) on each side of the wall
- No backfilling

Or

- Gap size is 0 mm to 40 mm
- Gap filler is CFS-S ACR
- Installation depth: ($t_{A2} \geq 25$ mm) on each side of the wall
- Backfilling with mineral wool, refer to Annex 2, chapter 2.2

With cementious mortar:

- Gap size is (0 mm to 40 mm), Installation depth: over the entire thickness
- Gap filler is mortar group M10 acc. EN 998-2

Collar fixing:

- For number of hooks for pipe coupling: refer to 3.2.2.18

3.3.2.14 Reuse of oddments of CFS-C EL ,

in rigid wall ($t_E \geq 100$ mm) for pipe group 1, EI 120 - U/U,
in rigid wall ($t_E \geq 150$ mm) pipe group 2, EI 90 - U/U

Situation:

- Reuse of oddments EI 120 - U/U for pipe group 1
- Reuse of oddments EI 90 - U/U for pipe group 2

Pipe range:

- For pipe group 1 – refer to 3.3.2.1; 3.3.2.2; 3.3.2.4; 3.3.2.5; 3.3.2.6; 3.2.2.12
- For pipe group 2 - refer to 3.3.2.20; 3.3.2.23; 3.3.2.24; 3.3.2.25; 3.3.2.26; 3.3.2.30

Installation details

- For installation details – refer to 3.1.7

number of hooks:

- For number of hooks – refer to 3.1.4 and 3.1.7

3.3.2.15 Hooks fixed in wet mortar for CFS-C EL,
in rigid wall ($t_E \geq 100$ mm) for pipe group 1, EI 120 - U/U and
in rigid wall ($t_E \geq 150$ mm), pipe group 2, EI 120 - U/U

Situation:

- Hooks in wet mortar in pipe group 1 : EI 120 - U/U
- Hooks in wet mortar in pipe group 2 : EI 120 - U/U

Pipe range:

- For pipe group 1 – refer to 3.3.2.1; 3.3.2.2; 3.3.2.4; 3.3.2.5; 3.3.2.6; 3.2.2.12
- For pipe group 2 - refer to 3.3.2.20; 3.3.2.23; 3.3.2.24; 3.3.2.25; 3.3.2.26; 3.3.2.30

Installation details:

- For installation details– refer to 3.1.3

number of hooks:

- For number of hooks – refer to 3.1.4 and Tab.3

3.3.2.16 PE pipes according EN 12201 (Wavin W) sealed with CFS-C EL ,
in rigid wall ($t_E \geq 100$ mm), pipe group 1, EI 120 - U/C

Situation:

- Isolated PE pipes acc .EN 12201 for EI120 - U/U

Pipe Range:

- Refer to graphic below
- Material type: PE acc.EN 12201 – Wavin W

Elastomeric foamed thermal insulation:

- For material type refer to 3.1.13
- Approved insulation thickness is ($t_D = 9$) mm
- Approved installation situation is LS and CS
- Minimum insulation length ($L_D \geq 250$ mm) on both sides of the wall

Pipe Range:

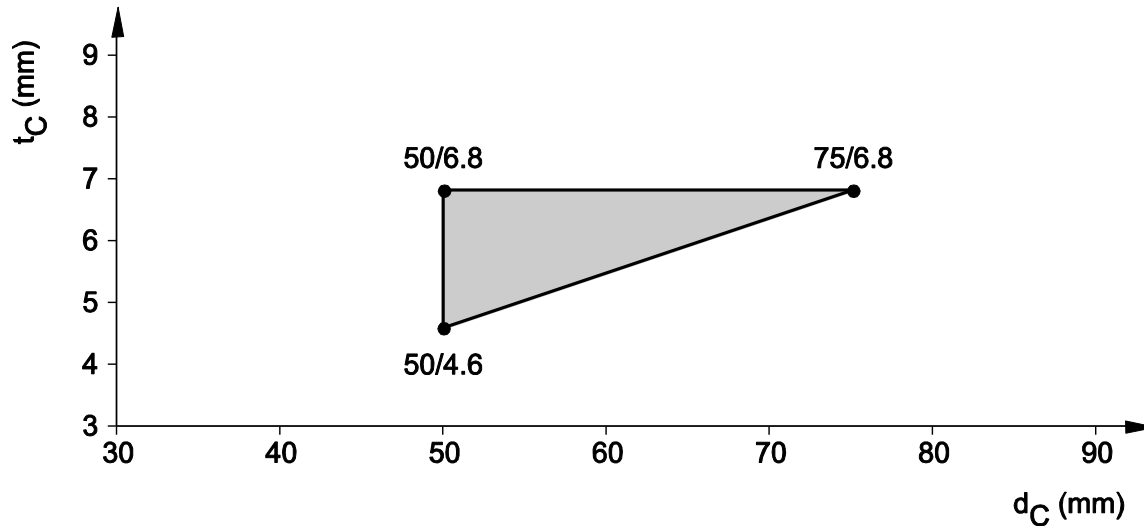

3.3.2.17 PP pipes, non-regulated, gap sealed with CFS-FIL,

in rigid wall ($t_E \geq 100$ mm), pipe group 1, EI 90 - U/U, elbow pipe 87°

Situation:

- Elbow connector (87°) for non-regulated PP pipes, installed inside the wall or partly inside the wall, sealed with Collar CFS-C EL for EI 90 – U/U classification
- On one side the pipe may run parallel to the wall having a zero distance to wall ($s_3 \geq 0$ mm).

Pipe range:

- For pipe group 1 – refer to; 3.3.2.5
- For pipe material – refer to 3.1.15

Gap size and Gap filler:

- Gap size is 5 mm to 40 mm
- Gap filler is CFS-FIL
- Installation depth: $t_{A3} \geq 25$ mm on each side of the wall
- Backfilling with mineral wool, refer to Annex 2, chapter 2.2

Collar fixing / number of hooks:

Pipe outside nominal diameter d_c (mm)	Acoustic Pipe Insulation Thickness t_D (mm)		
	(no elbow side - vertical running pipe / elbow side - horizontal running pipe)		
	0	4	9
32	2 / 2	2 / 2	2 / 2
50	2 / 2	2 / 2	2 / 3
75	3 / 3	3 / 3	3 / 3
90	3 / 3	3 / 3	3 / 3
110	3 / 4	3 / 4	3 / 4

If pipe insulation thickness is between 0 and 4 mm use the number of hooks indicated for 4 mm.

If pipe insulation thickness is between 4 and 9 mm use the number of hooks indicated for 9 mm.

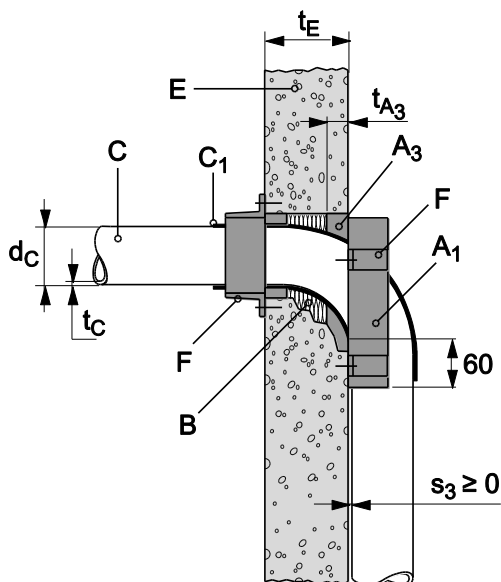

3.3.2.18 PP pipes, non-regulated, gap sealed with CFS-FIL , in rigid wall ($t_E \geq 100$ mm), pipe group 1, EI 120 - U/U, elbow pipe 2 x 45°

Situation:

- Elbow connector (2x45°) for non-regulated PP pipes installed inside the wall or partly inside the wall, sealed with Collar CFS-C EL for EI120 – U/U classification
- On one side the pipe may run parallel to the wall having a zero distance to wall ($s_3 \geq 0$ mm).

Pipe range:

- For pipe group 1 – refer to; 3.3.2.5
- For pipe material – refer to 3.1.15

Gap size and Gap filler:

- Gap size is 5 mm to 40 mm
- Gap filler is CFS-FIL
- Installation depth: $t_{A3} \geq 25$ mm on each side of the wall
- Backfilling with mineral wool, refer to Annex 2, chapter 2.2

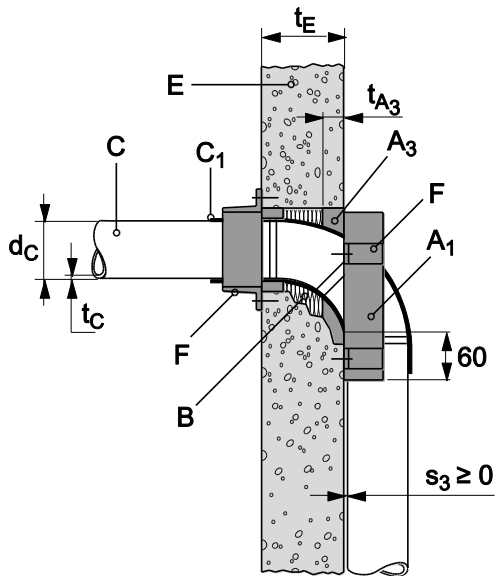

Collar fixing / number of hooks:

Pipe outside nominal diameter d_C (mm)	Acoustic Pipe Insulation Thickness t_D (mm)		
	(no elbow side - horizontal running pipe / elbow side - vertical running pipe)		
	0	4	9
32	2 / 2	2 / 2	2 / 2
50	2 / 2	2 / 2	2 / 3
75	3 / 3	3 / 3	3 / 3
90	3 / 3	3 / 3	3 / 3
110	3 / 4	3 / 4	3 / 4

If pipe insulation thickness is between 0 and 4 mm use the number of hooks indicated for 4 mm.

If pipe insulation thickness is between 4 and 9 mm use the number of hooks indicated for 9 mm.

3.3.2.19 All pipes named in 3.3.2.1; 3.3.2.2; 3.3.2.4; 3.3.2.5; 3.3.2.6; 3.2.2.12; rigid wall ($t_E \geq 100$ mm), pipe group 1, EI 120 - U/U,

Pipes directly mounted in the corner - zero distance pipe to one wall and one floor

Situation:

- Pipes directly mounted in the corner, sealed with Collar CFS-C EL for EI120 – U/U classification
- Zero distance ($s_3 \geq 0$ mm) pipe to one wall and one floor at same time,
- Collar CFS-C EL covers completely the circumference of sealed pipe.
- Some building material from affected building elements (from wall and floor) have to be removed to give free access for the collar.

Pipe range:

- For pipe group 1 only
 - For pipe material – refer to 3.3.2.1; 3.3.2.2; 3.3.2.4; 3.3.2.5; 3.3.2.6; 3.2.2.12
 - For pipe dimension - refer to 3.3.2.1; 3.3.2.2; 3.3.2.4; 3.3.2.5; 3.3.2.6; 3.2.2.12
- Excluded are pipes with outside nominal diameter ($d_c > 110$ mm).

Gap size and Gap filler:

With CFS-S ACR:

- Gap size is 0 mm to 15 mm
- Gap filler is CFS-S ACR
- Installation depth: ($10 \text{ mm} \leq t_{A3} \leq 20 \text{ mm}$) on each side of the wall
- No backfilling

or

- Gap size is 0 mm to 40 mm
- Gap filler is CFS-S ACR
- Installation depth: ($t_{A3} \geq 25 \text{ mm}$) on each side of the wall
- Backfilling with mineral wool, refer to Annex 2, chapter 2.2

With cementious mortar:

- Gap size is (0 mm to 40 mm)
- Gap filler is mortar group M10 acc. EN 998-2
- Installation depth: over the entire thickness of the wall

number of hooks:

- For number of hooks – refer to 3.1.4

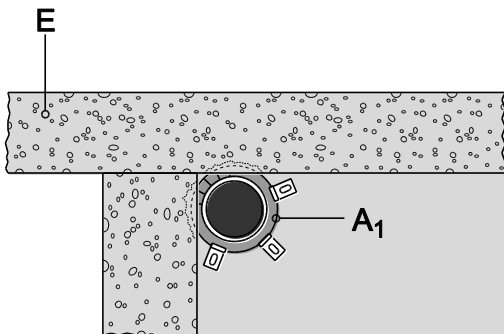

**3.3.2.20 PE pipes acc. EN1519-1, EN12201-2 and 12666-1,
in rigid wall ($t_E \geq 150$ mm), pipe group 2, EI 120 - U/U**

Pipe Range:

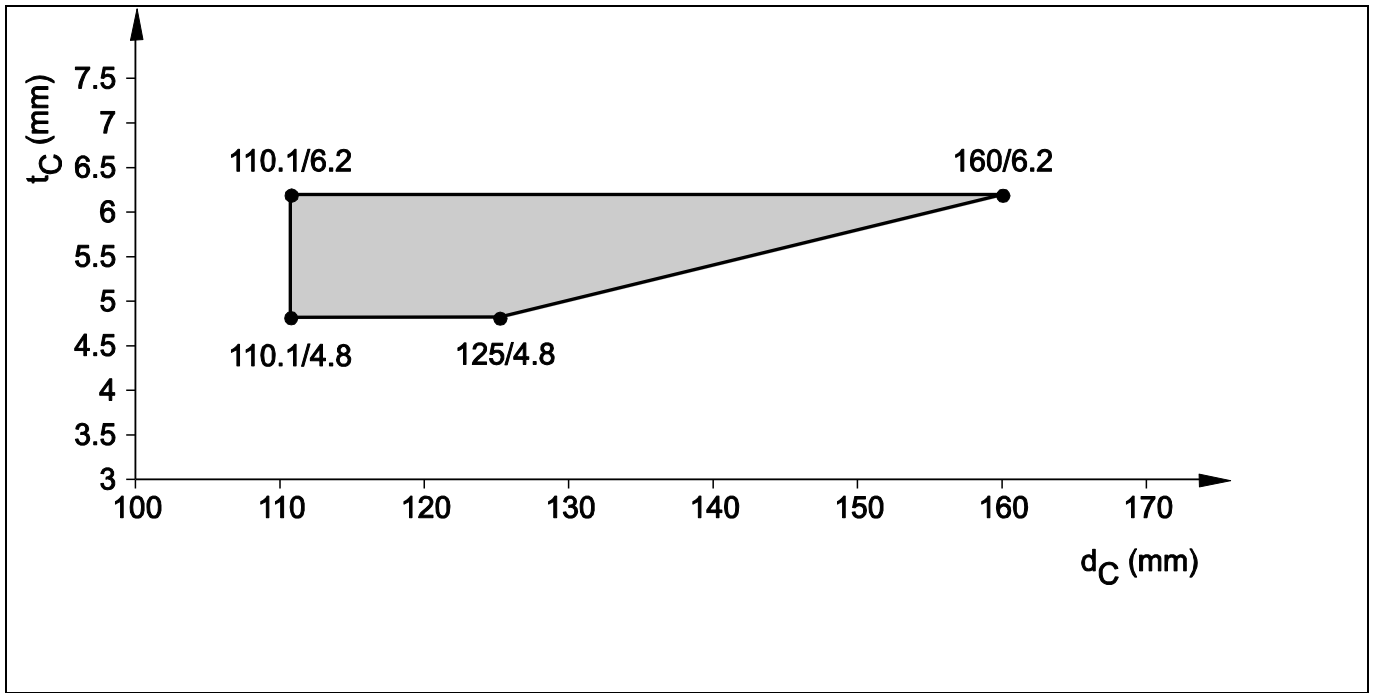

3.3.2.21 ABS pipes acc. EN1455-1, EN15493 and SAN+PVC-pipes acc. EN 1565-1, in rigid wall ($t_E \geq 150$ mm), pipe group 2, EI 90 - U/U

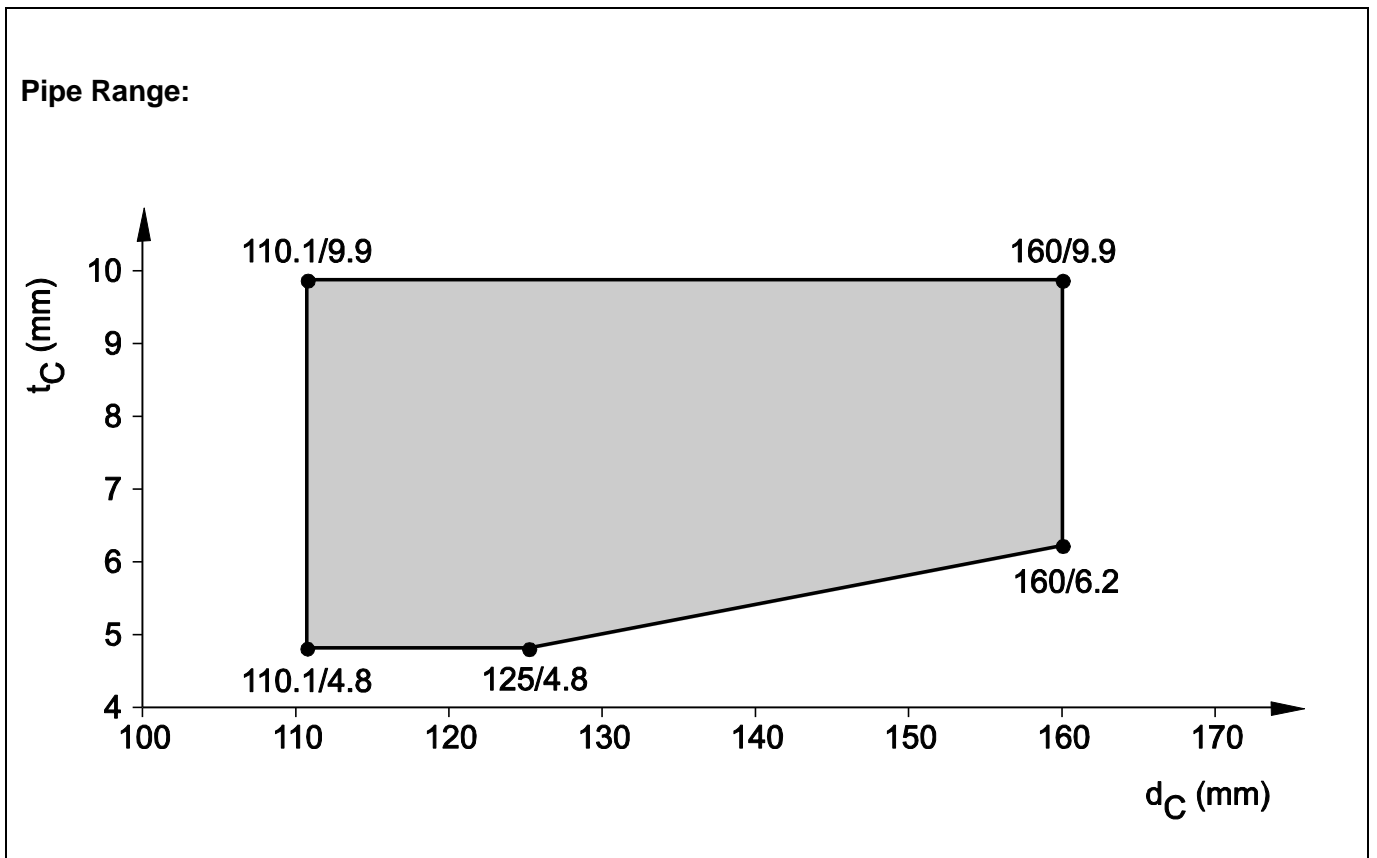

3.3.2.22 ABS pipes acc. EN1455-1, EN15493 and SAN+PVC-pipes acc. EN 1565-1, in rigid wall ($t_E \geq 150$ mm), pipe group 2, EI 120 - U/C



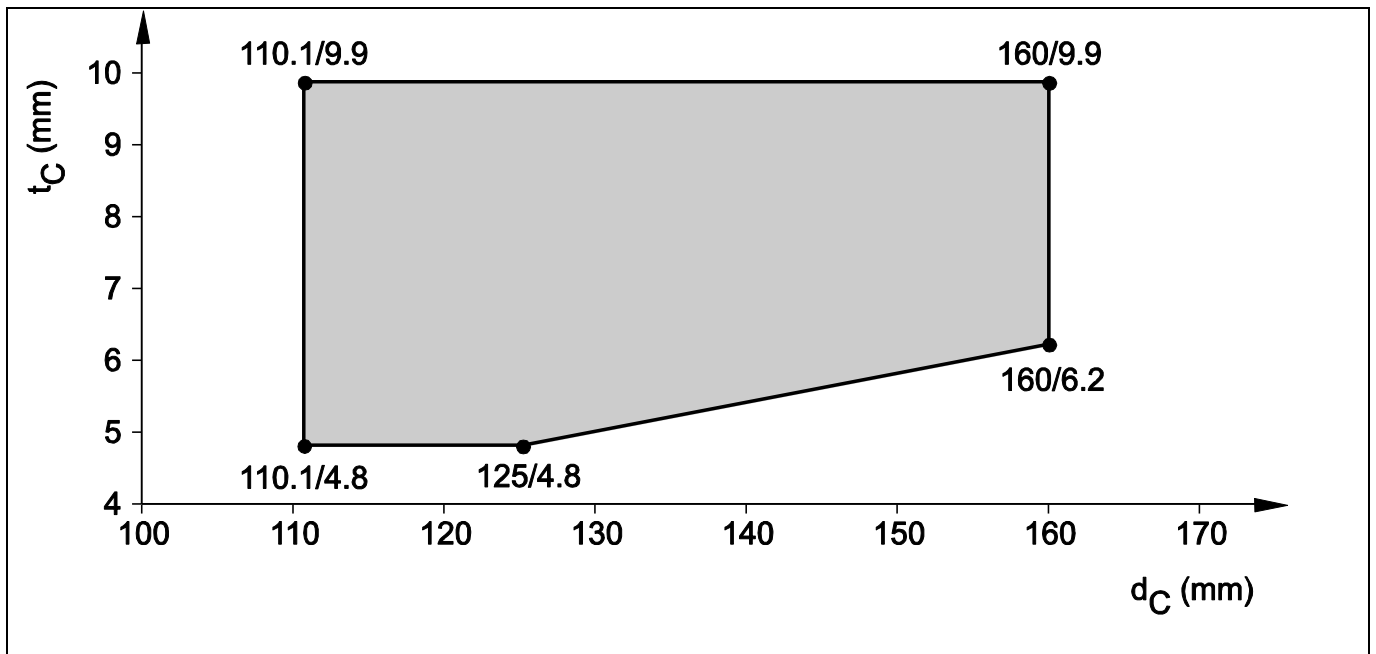

3.3.2.23 PE pipes acc. EN 15494, EN 12201-2 and DIN 8074/75,
in rigid wall ($t_E \geq 150$ mm), pipe group 2, EI 120 - U/U

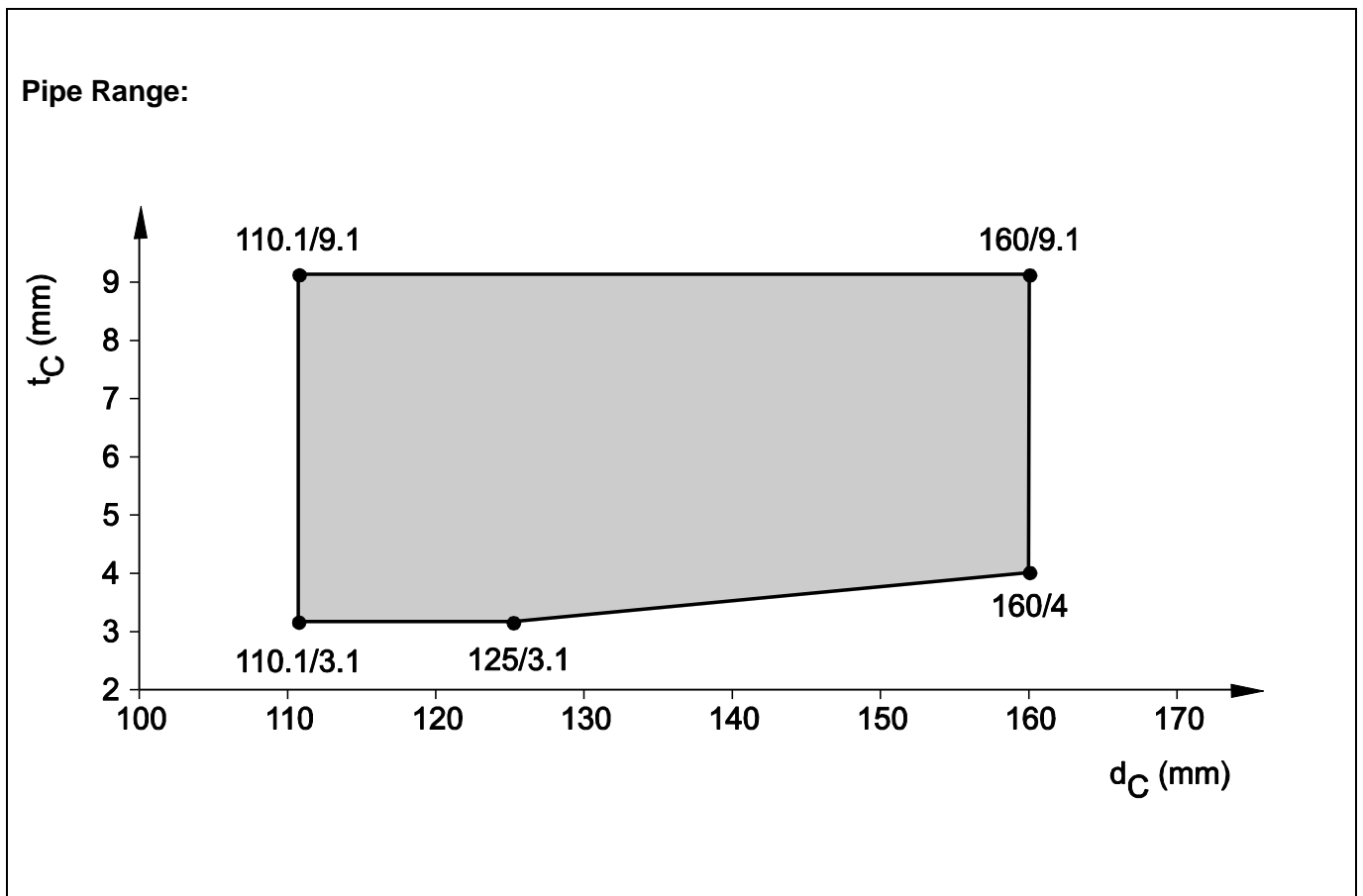

3.3.2.24 PVC pipes acc. EN 1452-1, EN 1329-1, EN 1453-1, EN1566-1, EN ISO 15493 and
DIN 8061/62, in rigid wall ($t_E \geq 150$ mm), pipe group 2, EI 120 - U/U

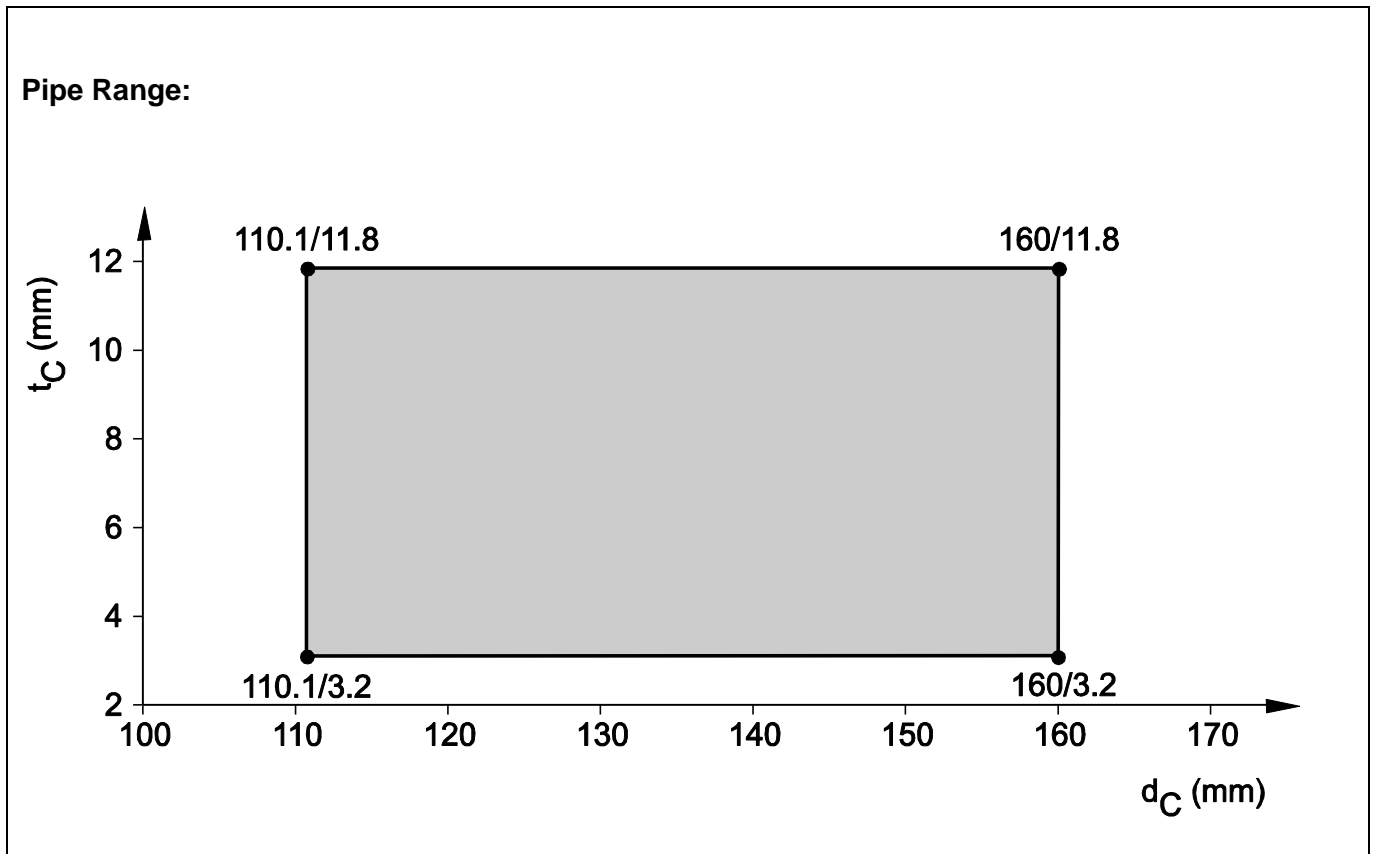

3.3.2.25 PP pipes , non-regulated,
in rigid wall ($t_E \geq 150$ mm), pipe group 2, EI 120 - U/U

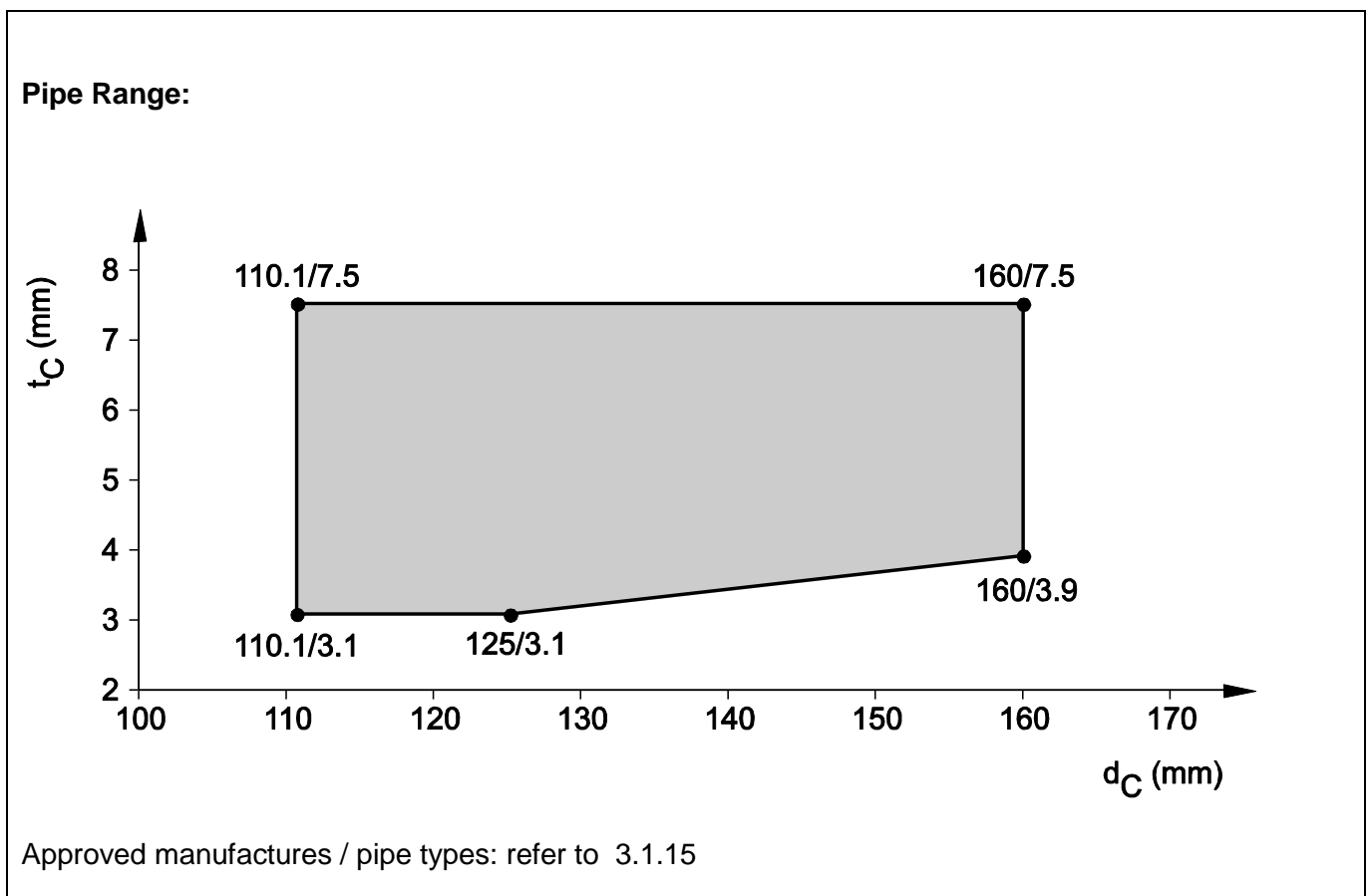

3.3.2.26 PP pipes acc. EN 1451-1 and DIN 8077/78,

in rigid wall ($t_E \geq 150$ mm), pipe group 2, EI 120 - U/U

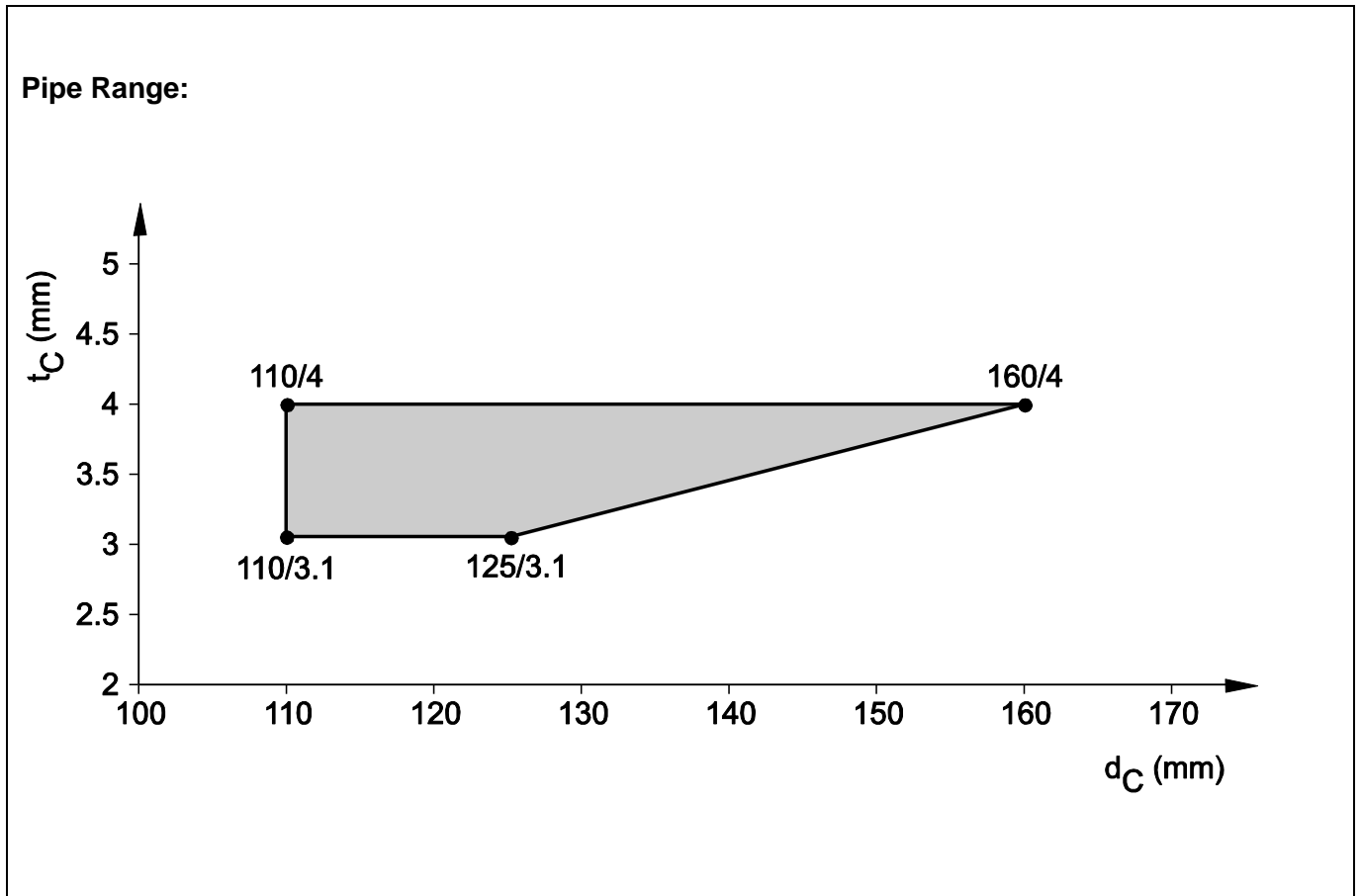

3.3.2.27 PP pipes acc. EN 1451-1 and DIN 8077/78,

in rigid wall ($t_E \geq 150$ mm), pipe group 2, EI 30 - U/U

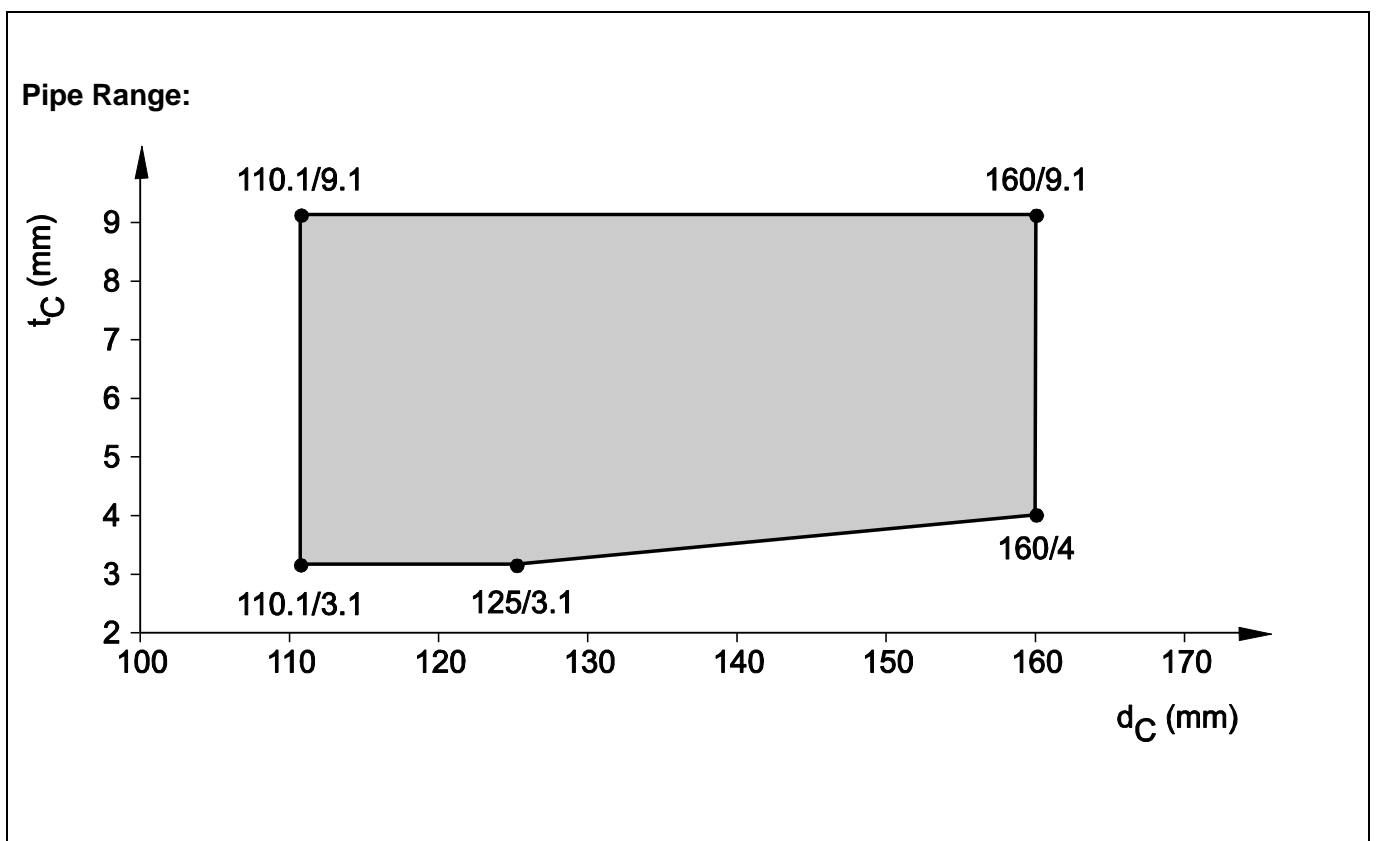

**3.3.2.28 PP pipes acc. EN 1451-1 and DIN 8077/78,
in rigid wall ($t_E \geq 150$ mm), pipe group 2, EI 120 - U/C**

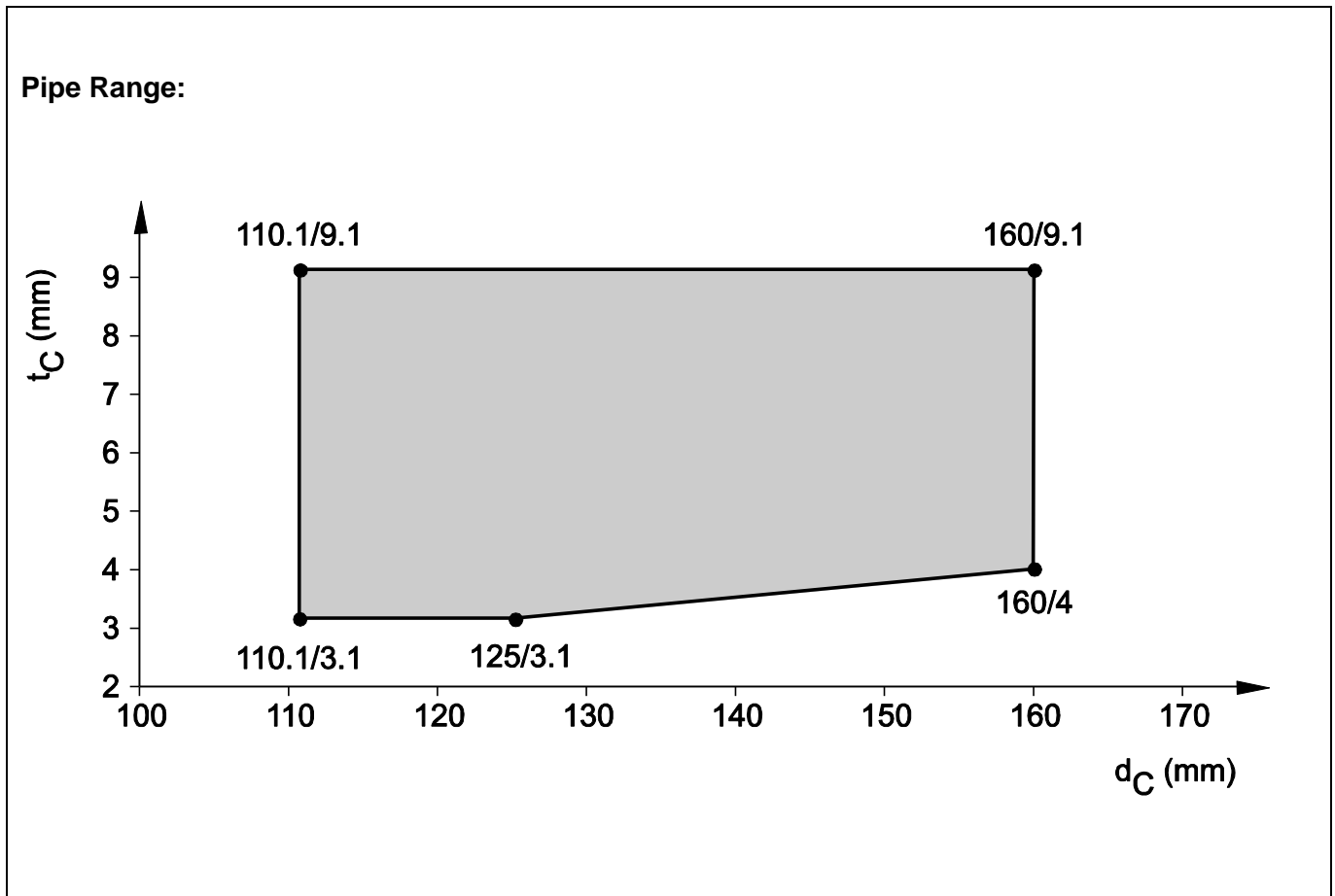

**3.3.2.29 Pneumatic dispatch system, PVC pipe acc. DIN 6660,
in rigid wall ($t_E \geq 150$ mm), pipe group 2, EI 90 - U/U**

Situation for EI 90 - U/U:

- PVC pipe acc. DIN 6660
- Pipe diameter ($110,1 \text{ mm} \leq d_C \leq 160 \text{ mm}$)
- Pipe wall thickness ($t_C = 3,2 \text{ mm}$)
- Pipe inclination : 90°
- Mixed penetration is allowed: pipe together with three cables, see below
- Cable in direct contact to pipe (single or bunched cables allowed)

Maximum cable size is:

- NYM-J $3 \times 2,5 \text{ mm}^2$
- J-Y (St) $Y 6 \times 2 \times 0,6 \text{ mm}^2$
- $2 \times 2,5 \text{ mm}^2$

**3.3.2.30 PE-pipes, non-regulated, (Geberit Silent dB20),
in rigid wall ($t_E \geq 150$ mm), pipe group 2, EI 120 - U/U**

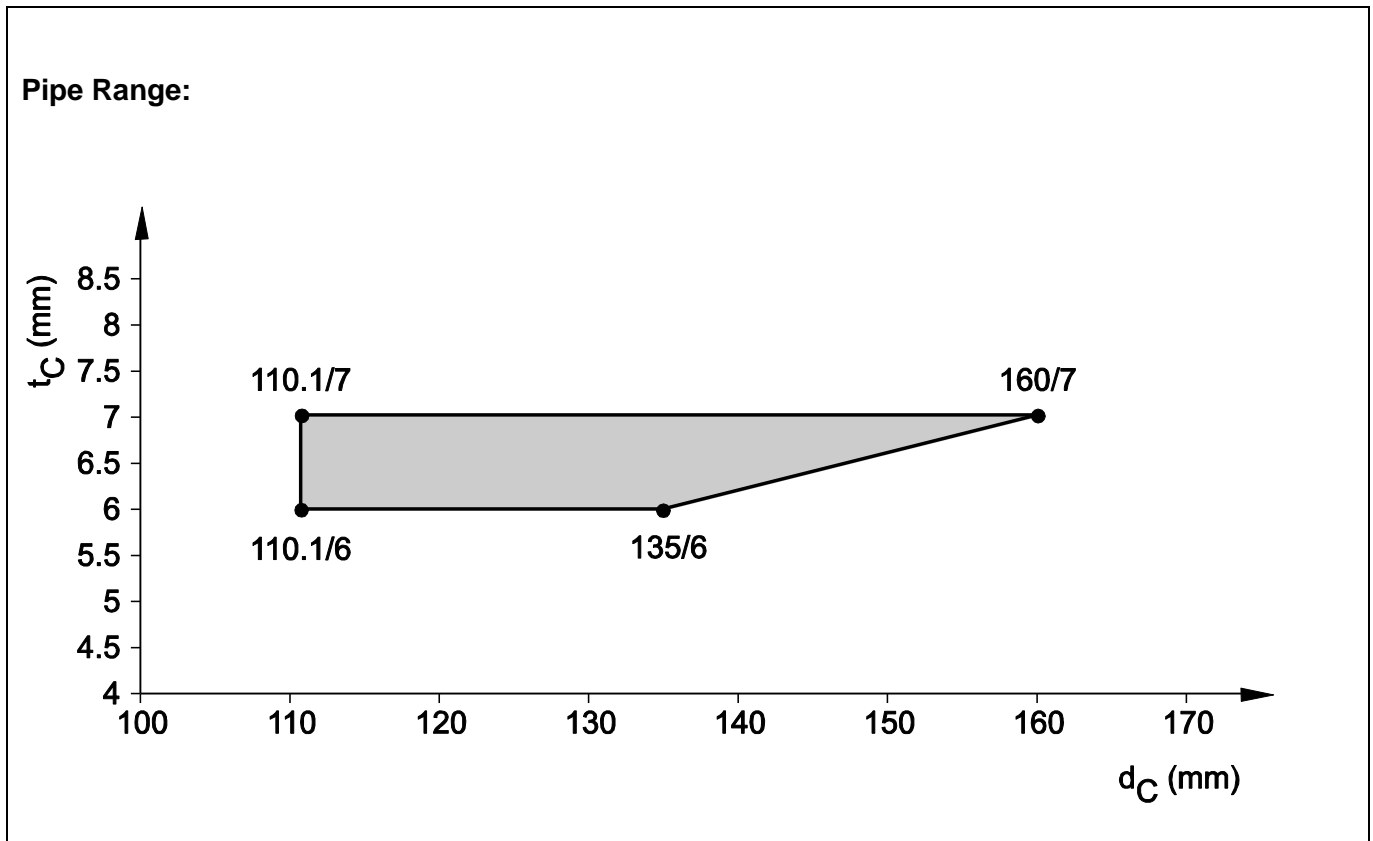

**3.3.2.31 PVC- pipes, non-regulated (Friatec Friaphon),
in rigid wall ($t_{RER} > 150$ mm), pipe group 2, EI 120 - U/U**

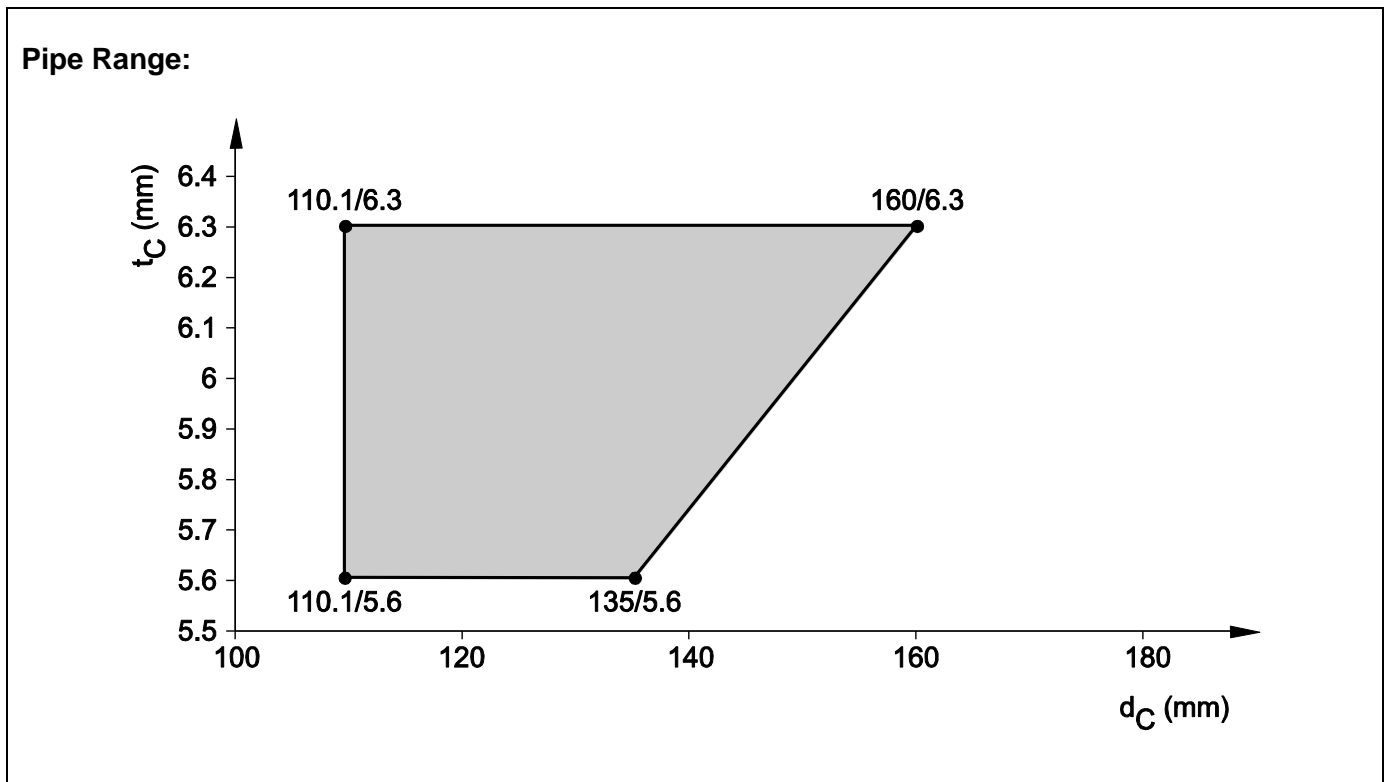

**3.3.2.32 All pipes named in 3.3.2.20, 3.3.2.23, 3.3.2.24, 3.3.2.25, 3.3.2.26, 3.3.2.30;
in rigid wall ($t_E \geq 150$ mm),
Zero distance collar to collar, pipe group 2, EI 90 - U/U**

Situation for EI 90 - U/U (refer to 3.1.9) :

- Zero distance between two CFS-C EL collars, sealing two plastic pipes ($s_1 \geq 0$ mm)
- Pipes have to be grouped in line only
- Max. 2 pipes side by side ($s_1 \geq 0$ mm) in one group
- Minimum distance group to group has to be ($s_2 \geq 60$ mm)
- Number of groups is unlimited

Type of pipes:

refer to 3.3.2.20,3.3.2.23, 3.3.2.24, 3.3.2.25, 3.3.2.26, 3.3.2.30

Range of pipes:

refer to 3.3.2.20,3.3.2.23, 3.3.2.24, 3.3.2.25, 3.3.2.26, 3.3.2.30

3.3.2.33 PP pipes acc. EN 1451-1

in rigid wall ($t_E \geq 150$ mm) pipe group 1, EI 120 - U/U, Pipe coupling

Situation for EI 120 - U/U:

- Pipe coupling inside the wall, half in the wall or outside the wall, covered by CFS-C EL
- Type of pipes: PP pipes acc. EN 1451-1
- Pipe insulation: see 3.1.6

Pipe range:

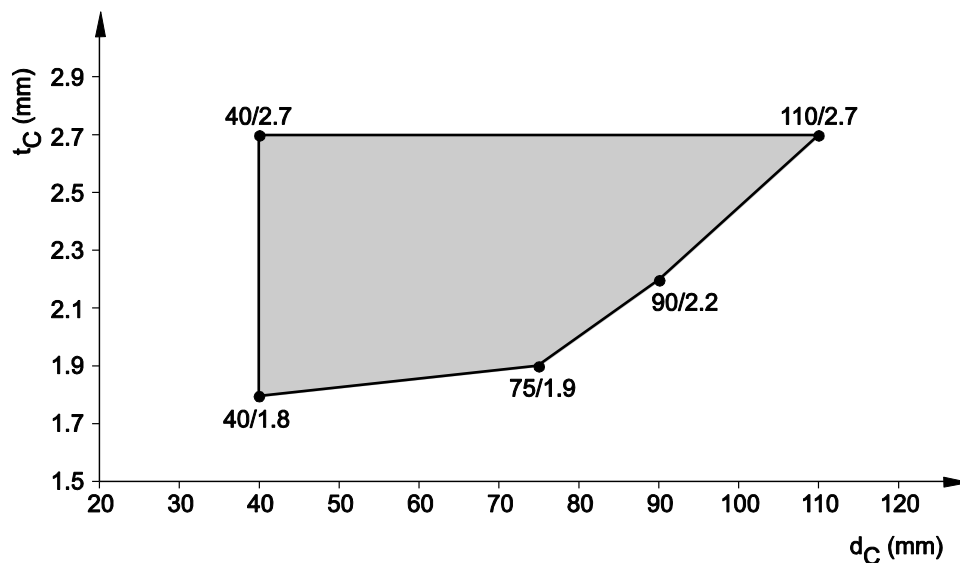

Gap size and gap filler:

In rigid wall application ($t_E \geq 150$ mm):

- Gap filler: Hilti CFS-FIL
- Annular gap: 5 – 40 mm
- Depth t_{A2} to be filled with Hilti CFS-FIL: ($t_{A2} \geq 25$ mm)
- No backfilling required

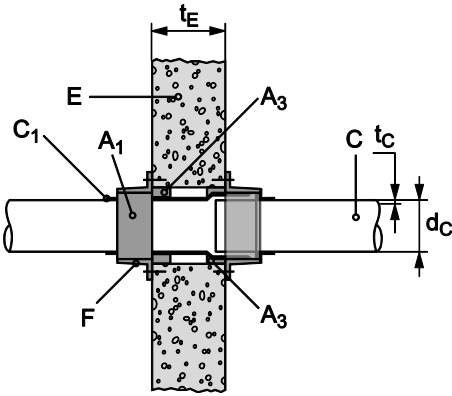

Requested number of hooks:

Pipe outside nominal diameter d_c (mm)	Acoustic Pipe Insulation Thickness t_D (mm) (incoming pipe / outgoing pipe)		
	0	4	9
40	2 / 2	2 / 2	2 / 2
41 - 75	3 / 3	3 / 3	3 / 3
76 - 90	3 / 3	3 / 3	3 / 3
91 - 110	3 / 4 (on coupling)	3 / 4	3 / 4

If pipe insulation thickness is between 0 and 4mm use the number of hooks indicated for 4 mm. If pipe insulation thickness is between 4 and 9 mm use the number of hooks indicated for 9 mm.

3.4 Rigid floor

3.4.1 Specific characteristics for Rigid floor ($t_E \geq 150$ mm)

3.4.1.1 Rigid floor:

The floor must have a minimum thickness of 150 mm with a minimum density of $\rho_E \geq 650$ kg/m³ and comprise concrete, aerated concrete or masonry.

3.4.1.2 Annular gap

Annular gap around penetrating item has to be filled with:

- Cementitious mortar acc. EN 998-2 group M10 over the entire thickness of the floor or
- Hilti Firestop Acrylic Sealant CFS-S ACR (A_2) on top side of floor only with a depth of minimum ($t_{A2} \geq 25$ mm), backfilled with mineral wool or
- Hilti Firestop Acrylic Sealant CFS-S ACR (A_2) only, installation depth $t_{A2} = (t_{A2} \geq 25$ mm), installed on both sides of floor

Annular gap width should be:

- 0 – 40 mm (when sealed with mortar group M10 acc. EN 998-2 over the entire wall thickness)
- 0 – 40 mm (when sealed with Hilti Firestop Acrylic Sealant CFS-S ACR and mineral wool backfilling)
- 0 – 15 mm (when sealed with Hilti Firestop Acrylic Sealant CFS-S ACR only)

3.4.1.3 Collar fixing

Hilti Firestop Collar Endless CFS-C EL (A_1) has to be fixed with hooks (F) on the bottom side of the floor. A collar seal is requested from the lower side only.

The requested number and type of hooks is shown in 3.1.4 and Tab.3.

Hooks fixing in rigid floor is described in 3.1.3 and Tab.2.

Bended hooks could be pressed into the wet gap seal, made of cementitious mortar. For details regarding Integrity and insulation in pipe group 1 and pipe group 2 refer to 3.4.2

Mortar must be fully cured before fire rating is available.

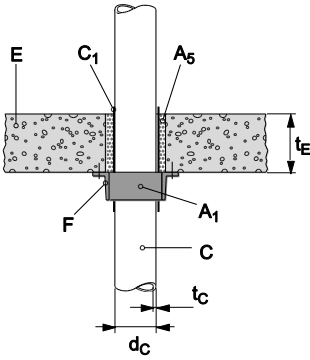
<p>Plastic pipe, penetrating a rigid floor, sealed with Hilti Firestop Collar CFS-C EL. Used gap filler is mortar group M10 acc. EN 998-2 over the entire wall thickness. Plastic pipe could be covered or uncovered by an acoustical insulation.</p>	
---	--

Plastic pipe, penetrating a rigid floor, sealed with Hilti Firestop Collar CFS-C EL. Used gap filler is CFS-S ACR in a thickness of ($t_{A2} \geq 25$ mm) from the upper surface of the floor only, backfilled with mineral wool. Plastic pipe could be covered or uncovered by an acoustical insulation.

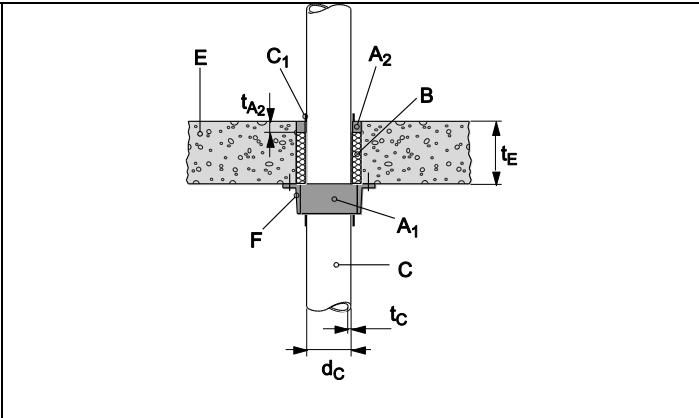

Plastic pipe, penetrating a rigid floor, sealed with Hilti Firestop Collar CFS-C EL. Used gap filler is CFS-S ACR in a thickness of ($t_{A2} \geq 25$ mm) from both surfaces of the floor, no backfilling is requested. Plastic pipe could be covered or uncovered by an acoustical insulation.

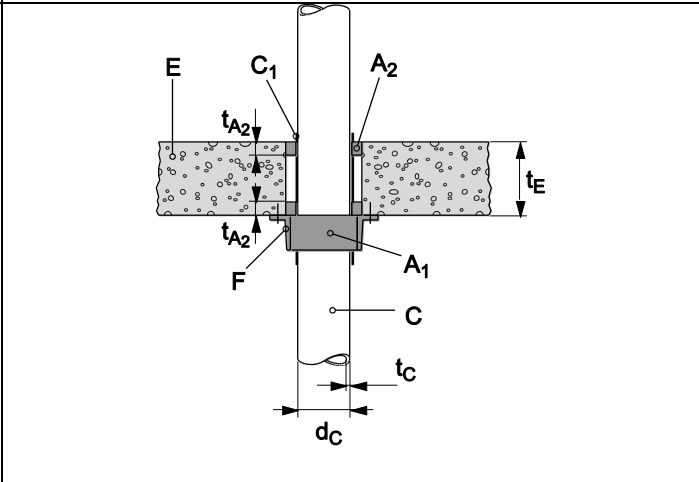

3.4.2 Penetration services in rigid floor ($t_E \geq 150$ mm)

3.4.2.1 PE pipes acc. EN 1519-1, EN12201-2 and EN 12666-1

in rigid floor ($t_E \geq 150$ mm), pipe group 1, EI 120 - U/U

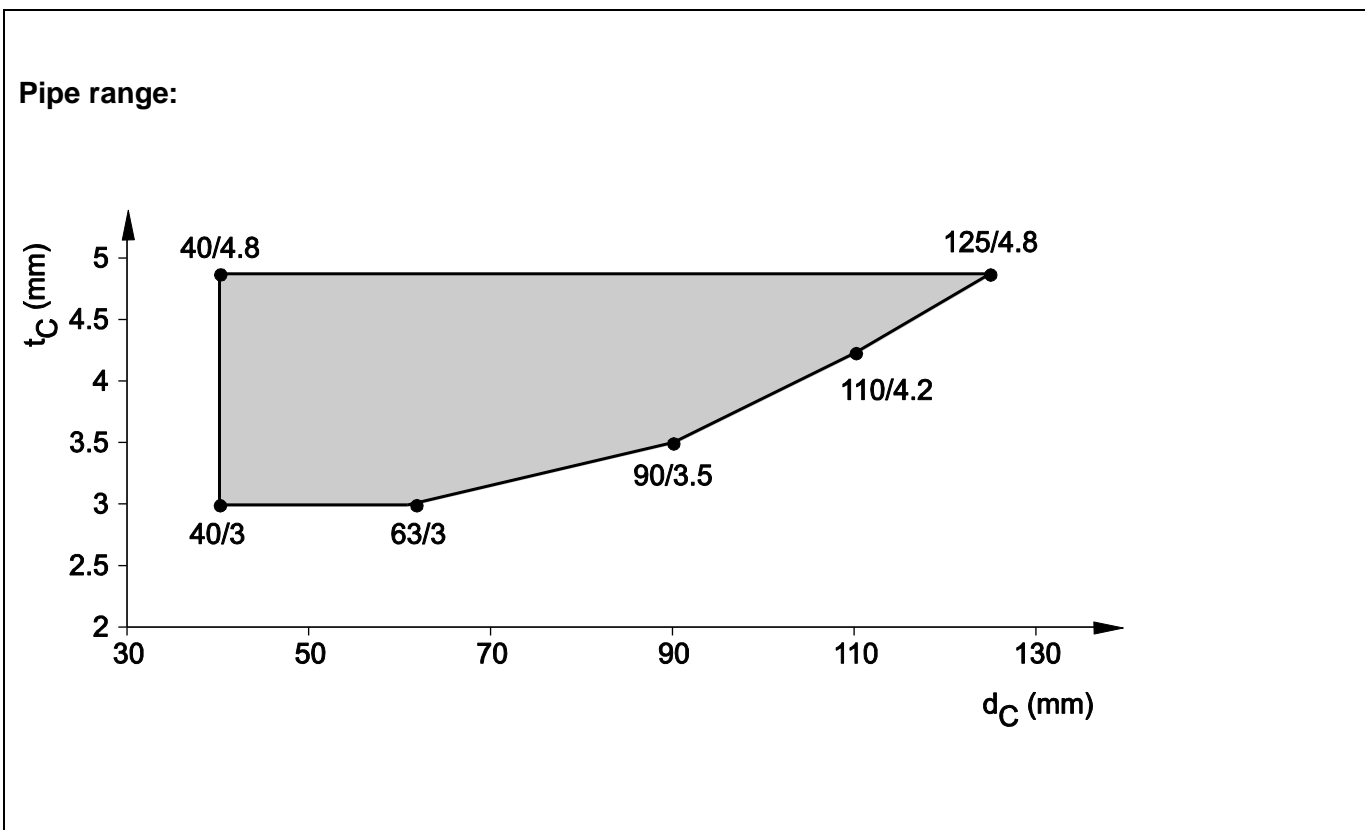

**3.4.2.2 ABS pipes acc. EN 1455-1, EN 15493 and SAN+PVC-pipes acc. EN 1565-1,
in rigid floor ($t_E \geq 150$ mm), pipe group 1, EI 120 - U/U**

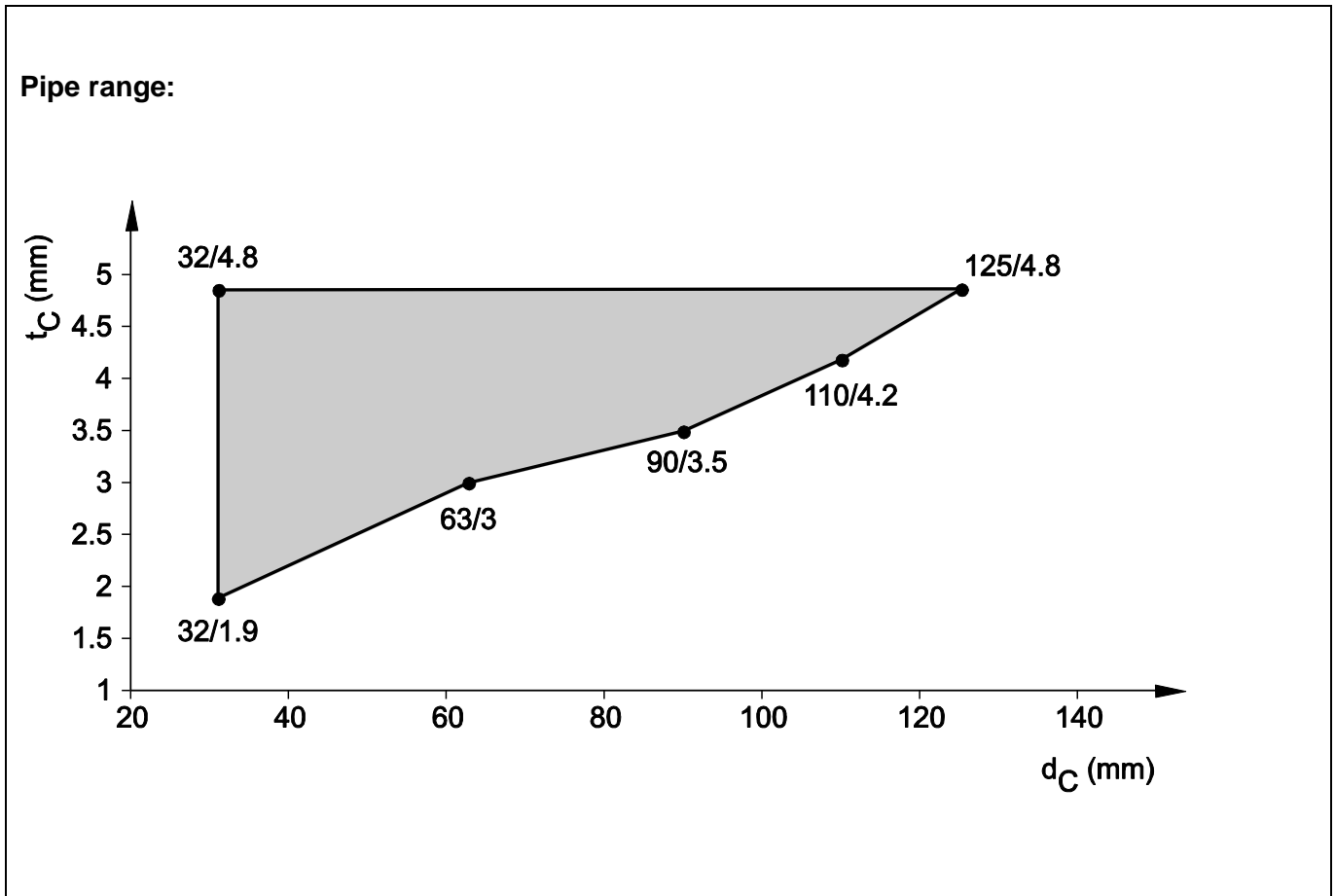

**3.4.2.3 PE pipes acc. EN 15494, EN12201-2 and DIN 8074/75
in rigid floor ($t_E \geq 150$ mm), pipe group 1, EI 120 - U/U**

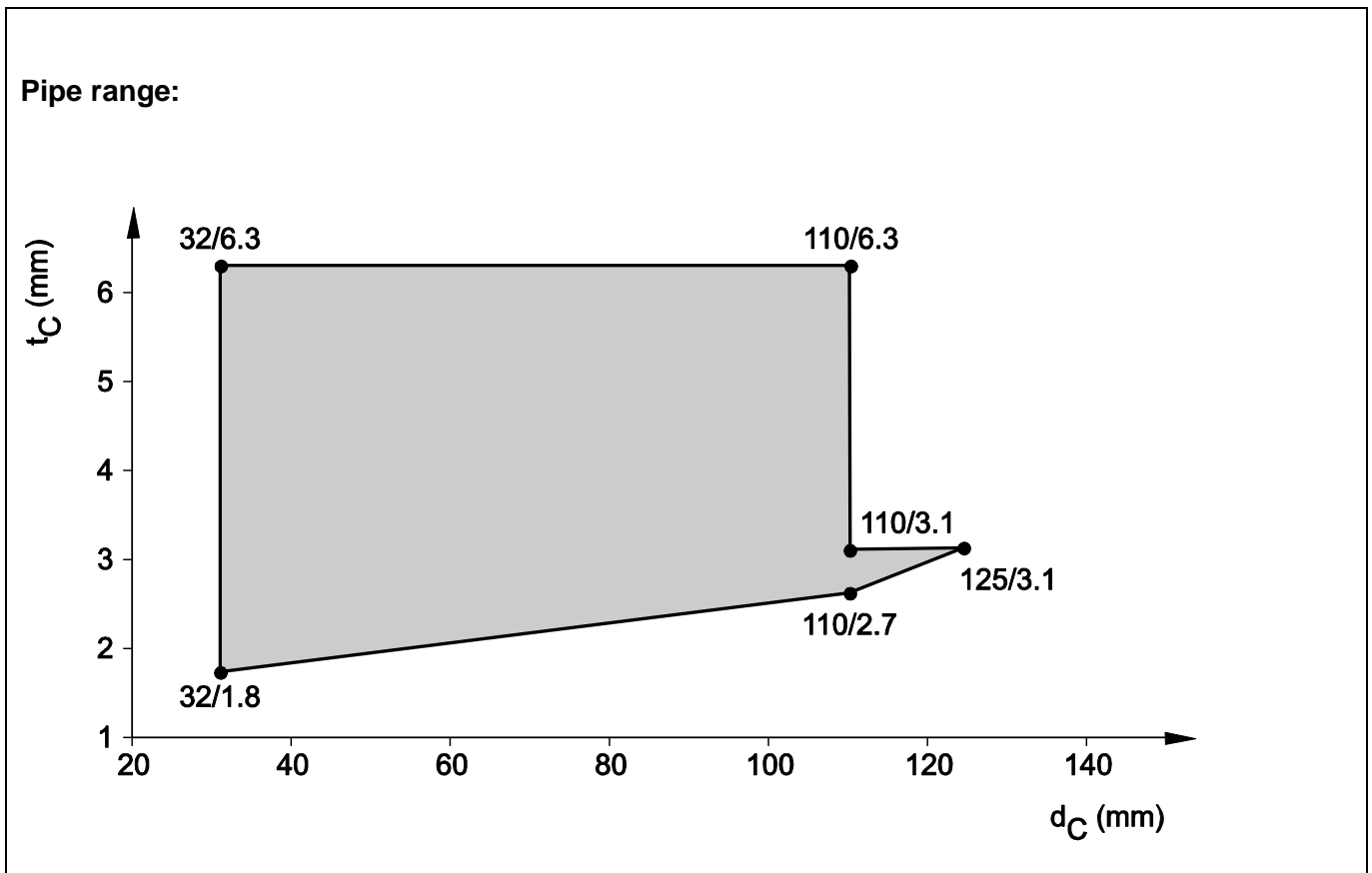

3.4.2.4 PVC pipes acc. EN 1452-1, EN1329-1,EN1453-1, EN1566-1 EN ISO 15493 and DIN 8061/62 in rigid floor ($t_E \geq 150$ mm), pipe group 1, EI 120 - U/U

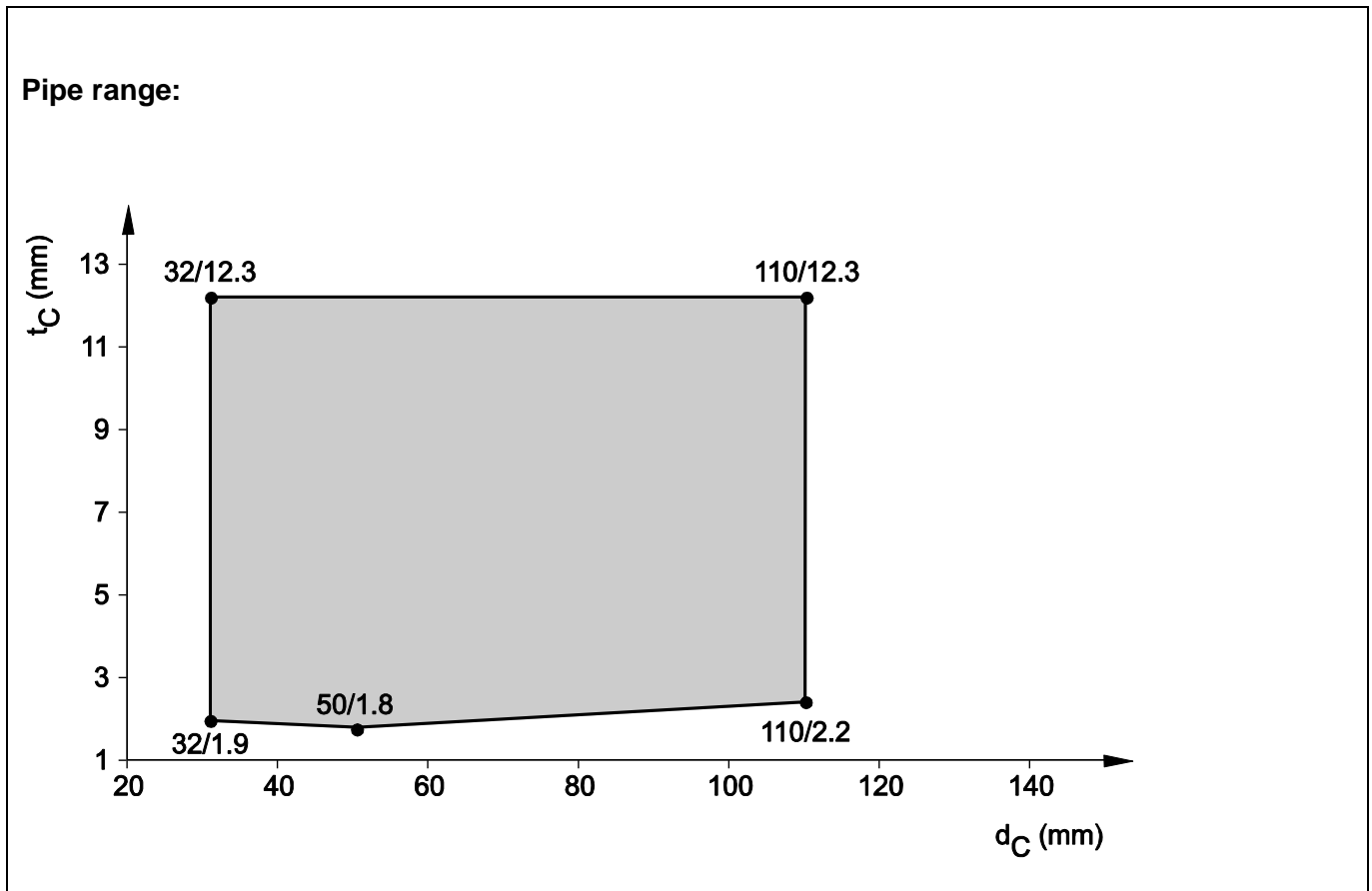

3.4.2.5 PVC pipes acc. EN 1452-1, EN1329-1, EN1453-1,EN1566-1 EN ISO 15493 and DIN 8061/62, in rigid floor ($t_E \geq 150$ mm), pipe group 1, EI 90 - U/U

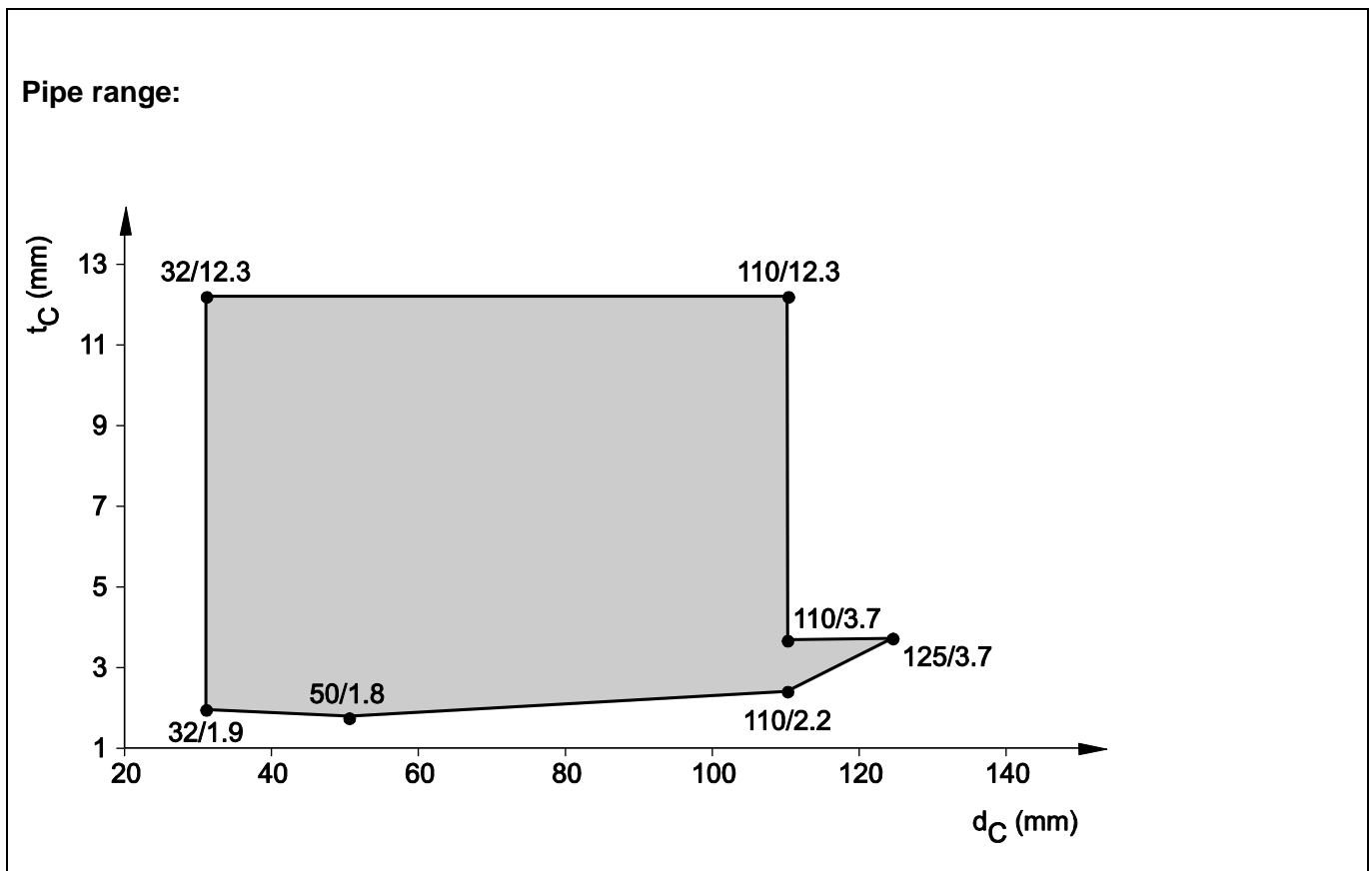

**3.4.2.6 PP pipes , non-regulated, pipe types: refer to 3.1.15
in rigid floor ($t_E \geq 150$ mm), pipe group 1, EI 120 - U/U**

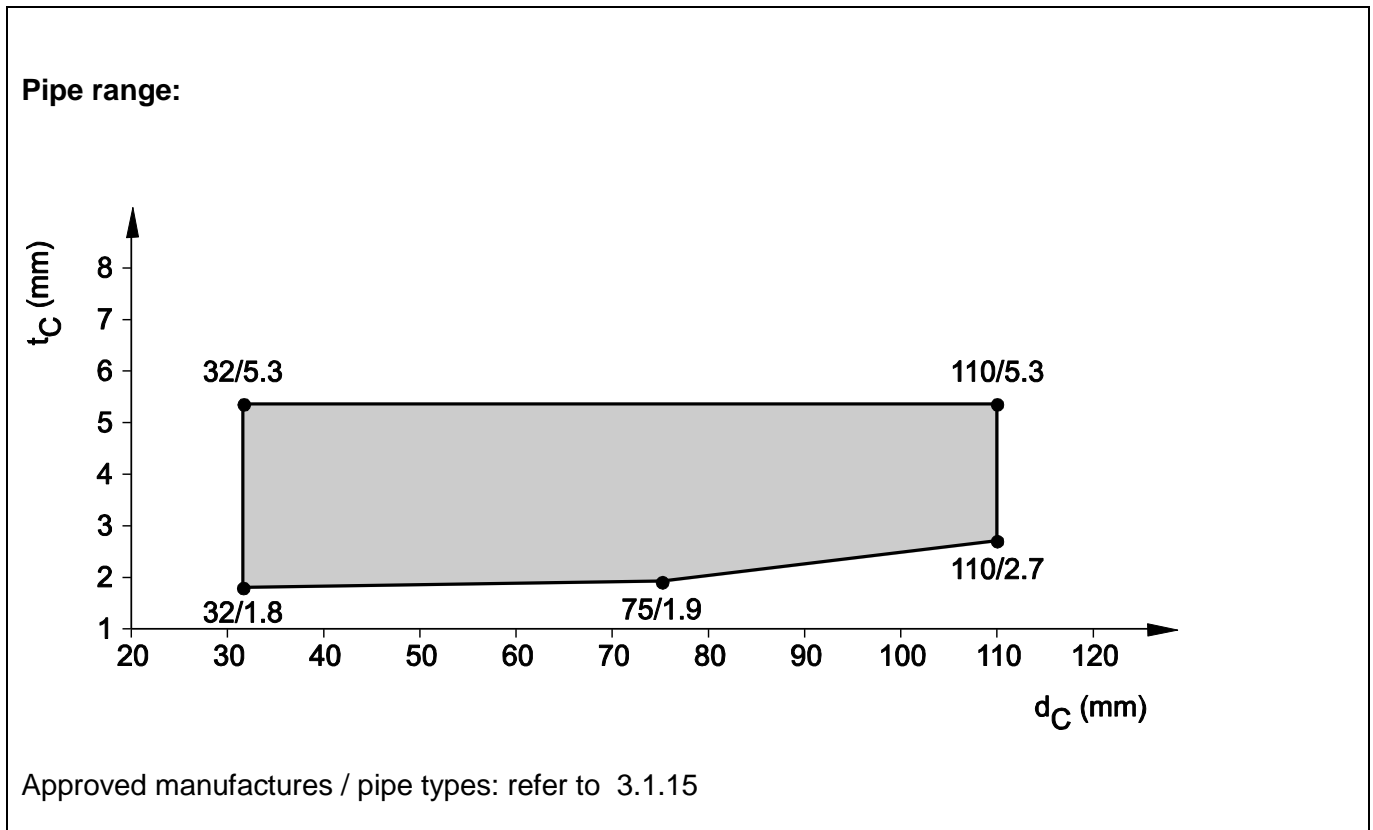

**3.4.2.7 PP pipes acc. EN 1451-1 and DIN 8077/78,
in rigid floor ($t_E \geq 150$ mm), pipe group 1 , EI 120 - U/U**

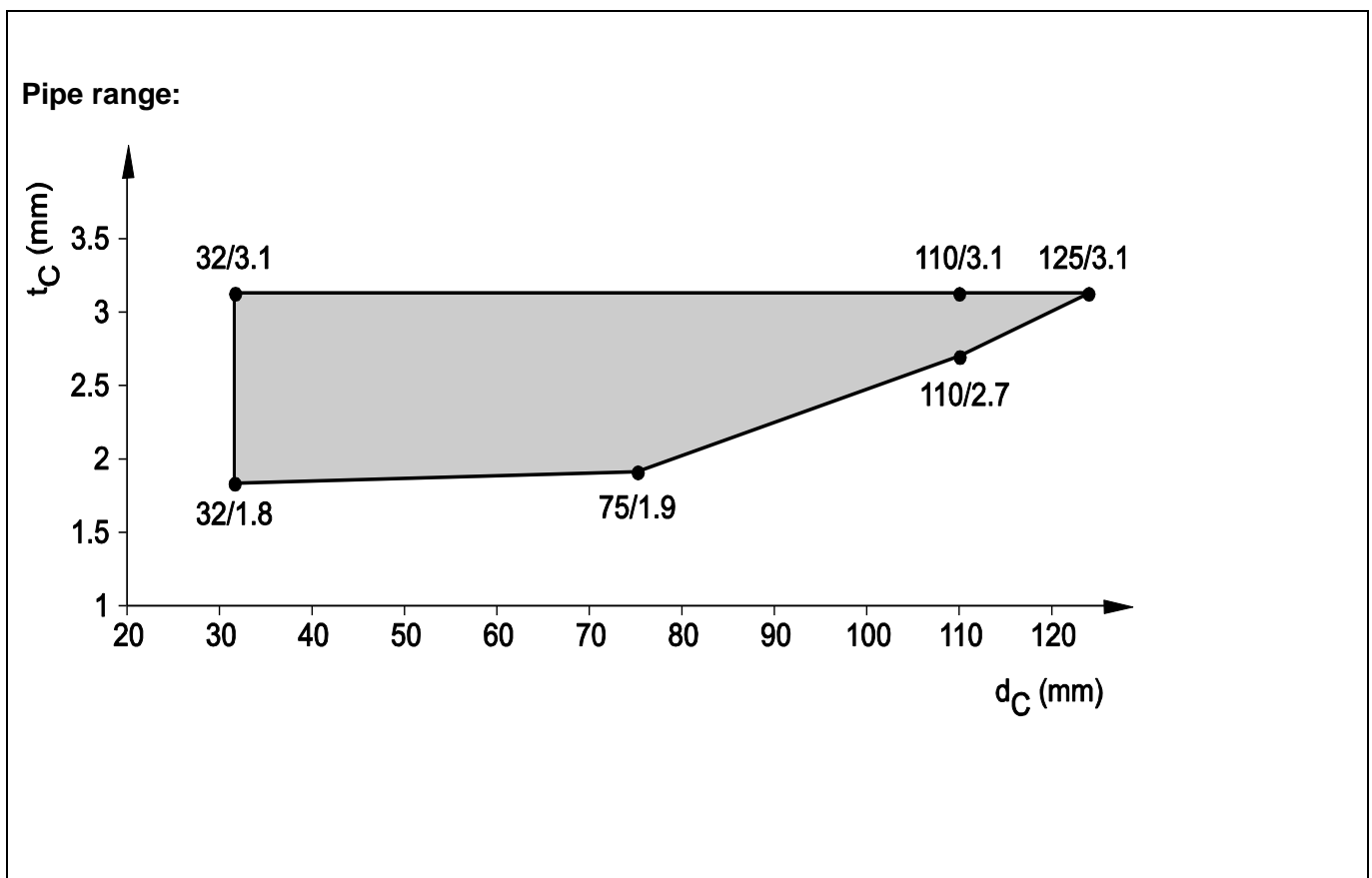

3.4.2.8 PP pipes acc. EN 1451-1 and DIN 8077/78,
in rigid floor ($t_E \geq 150$ mm), pipe group 1, EI 90 - U/U

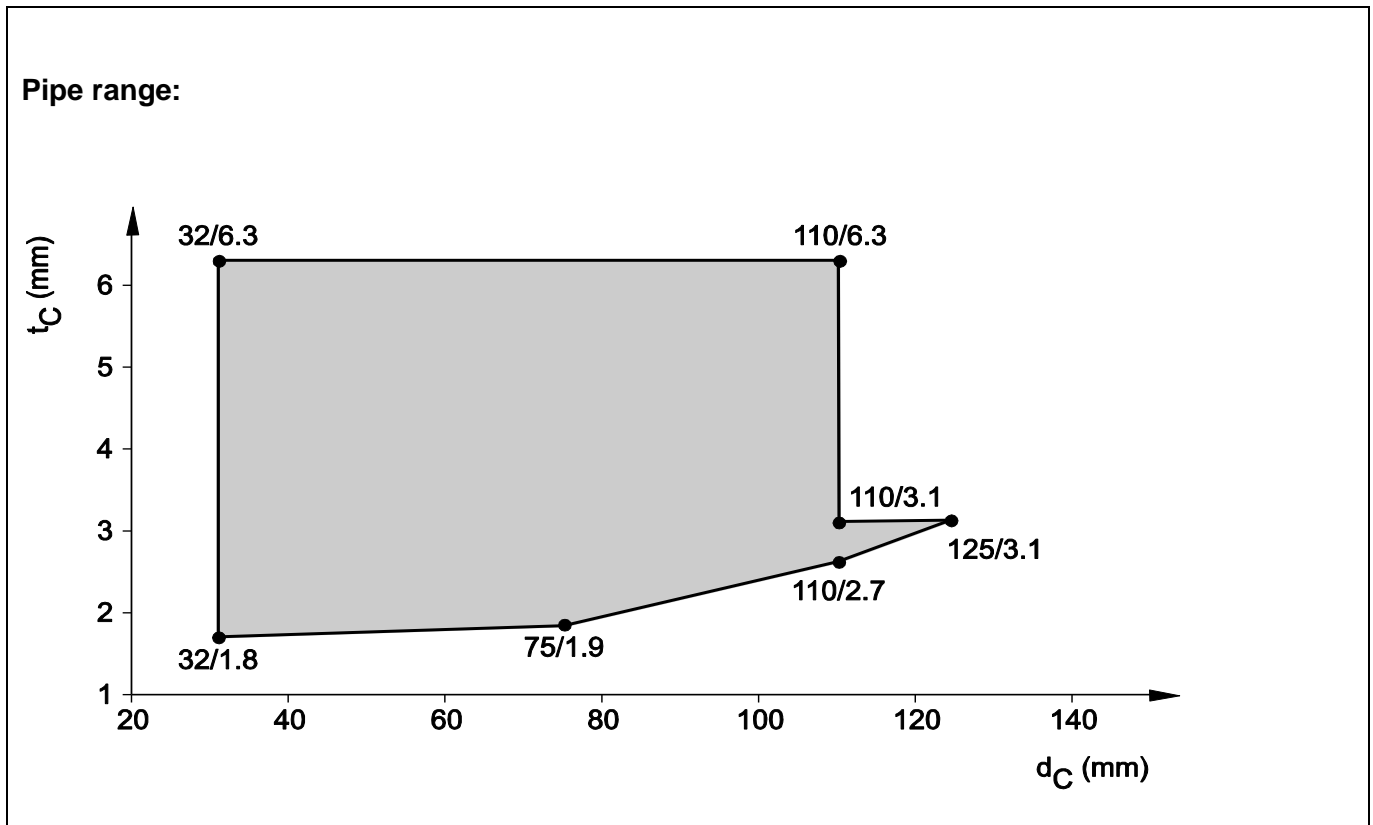

3.4.2.9 PP pipes acc. EN 1451-1 and DIN 8077/78,
in rigid floor ($t_E \geq 150$ mm), pipe group 1, EI 120 - U/C

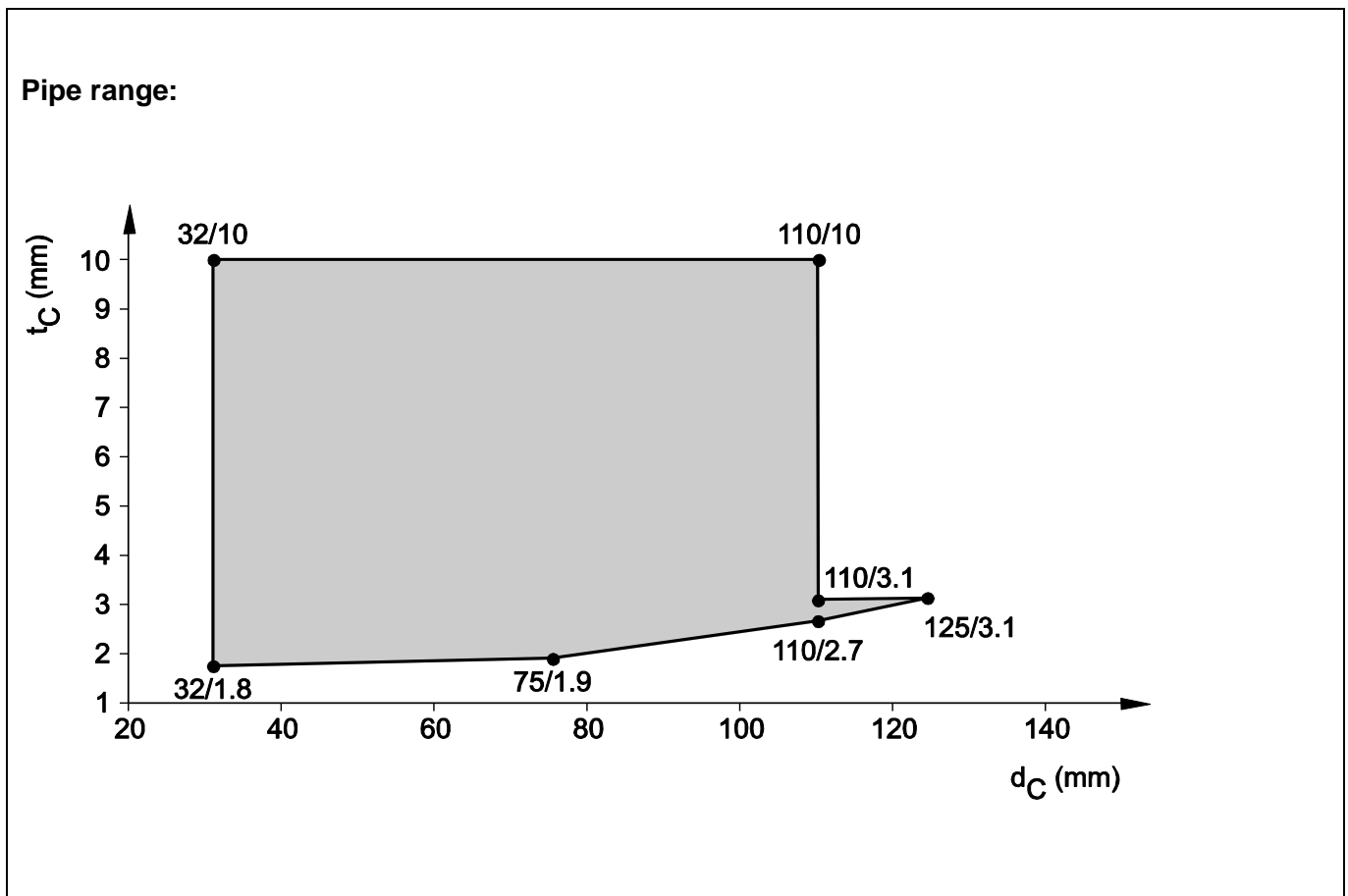

**3.4.2.10 PE pipes , non-regulated (Geberit Silent dB20),
in massive floor ($t_E \geq 150$ mm), pipe group 1, EI 120 - U/U**

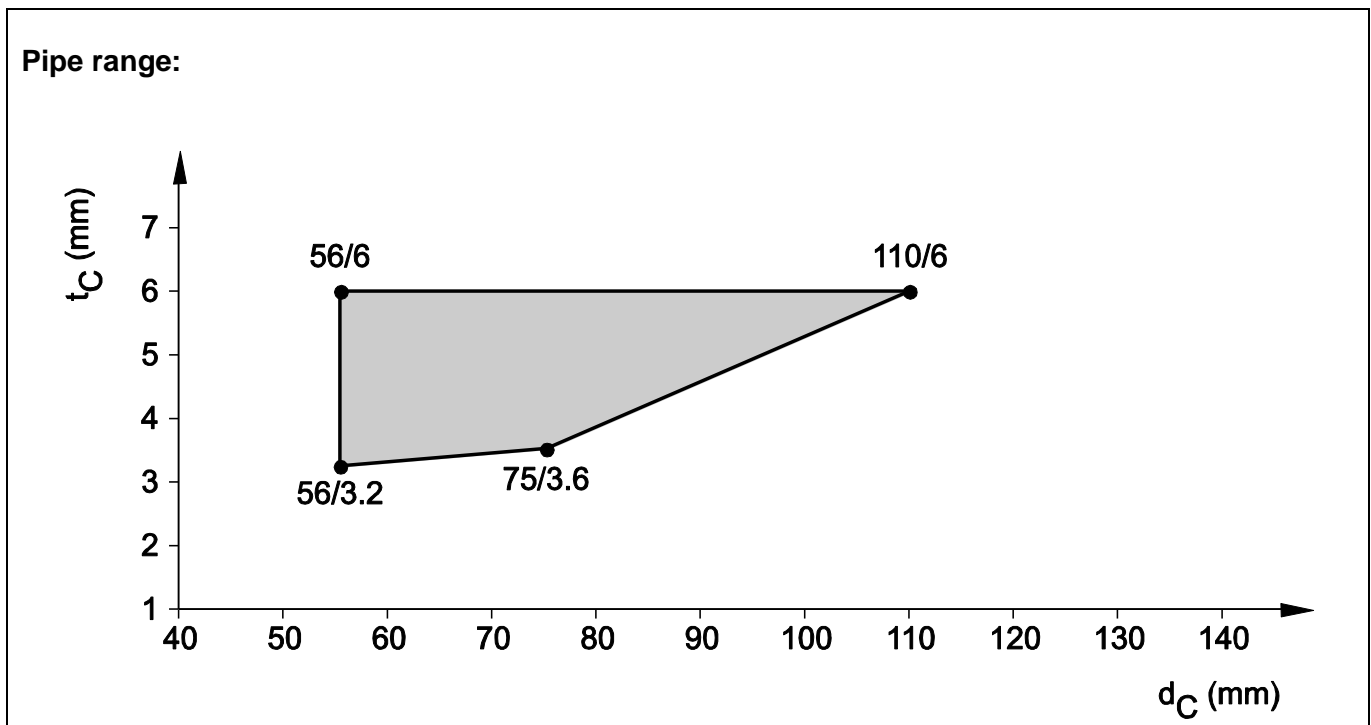

**3.4.2.11 PVC-pipes, non-regulated (Friatec Friaphon)
in rigid floor ($t_E \geq 150$ mm), pipe group 1, EI 180 - U/U**

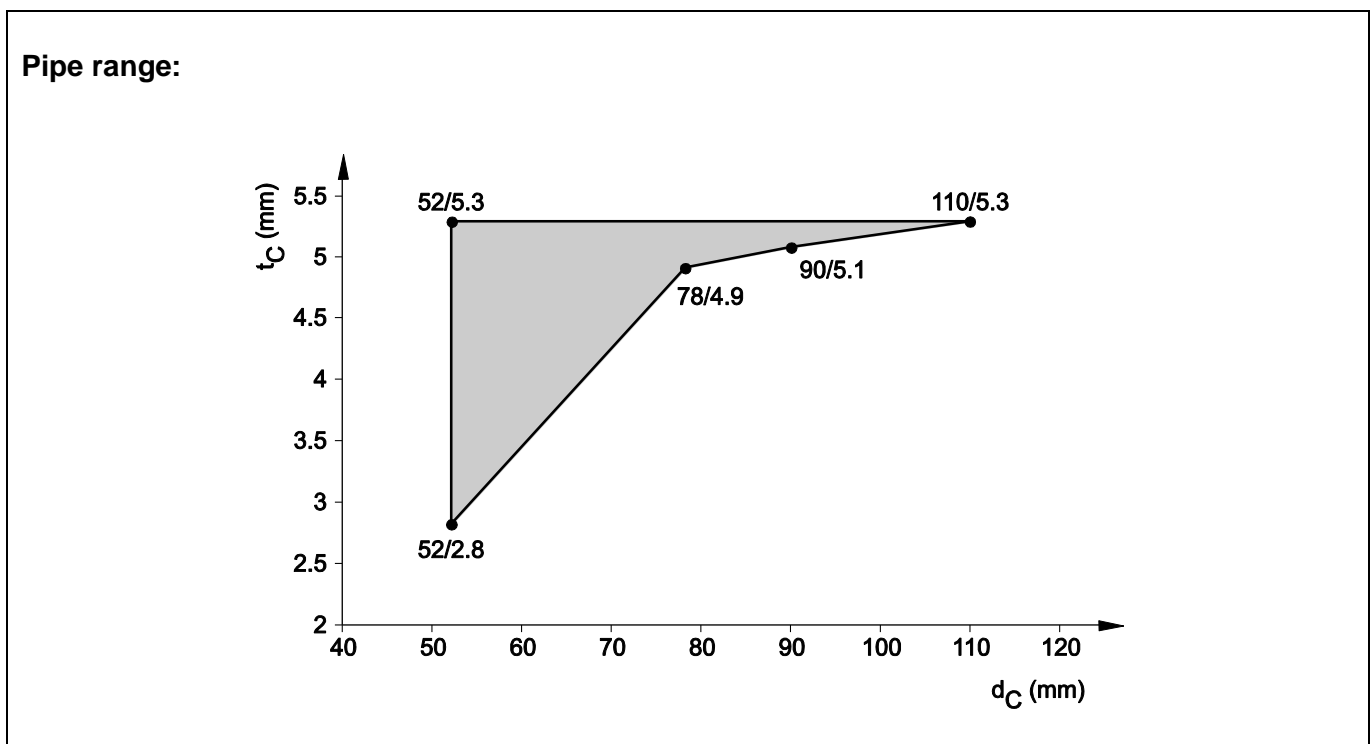

**3.4.2.12 Pneumatic dispatch system, PVC-U pipes acc. DIN 6660, in rigid floor
($t_E \geq 150$ mm), pipe group 1, EI 120 - U/U, Pipe inclination : ($45^\circ < \text{pipe inclination} < 90^\circ$)**

Situation for EI 120-U/U:

- PVC pipe acc. DIN 6660
- Pipe diameter ($d_C \leq 110$ mm)

- Pipe wall thickness ($t_c = 2,3 \text{ mm}$)
- Pipe inclination : ($45^\circ \leq \text{pipe inclination} \leq 90^\circ$)
- Mixed penetration is allowed: pipe together with maximum three cables, see below
- Cable in direct contact to pipe (single or bunched cables tested)

Maximum approved cable size is:

- NYM-J 3x2,5 mm²
- J-Y (St) Y 6 x 2 x 0,6 mm²
- 2 x 2,5 mm²

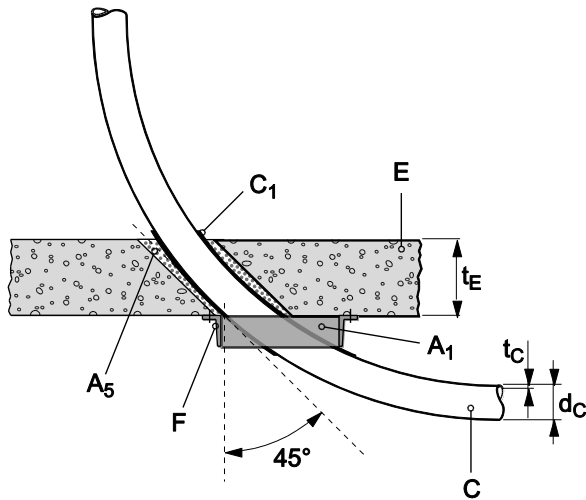

3.4.2.13 PE pipe with coupling or 2x45° elbow and electro welding coupler

3.4.2.13A PE pipes, non-regulated (Geberit Silent dB20),

in rigid floor ($t_E \geq 150 \text{ mm}$), pipe group 1, EI 120 - U/U

straight (90°), 2 x 45° elbow pipe connector

Situation for Geberit Silent dB20 EI 120 - U/U:

- Pipe elbow connector (2 pieces each of 45°) made of PE only with electric welding wire inside
- Pipe elbow connector (2x45°) is approved to be inside the floor or directly above/below the floor, covered by CFS-C EL on the bottom side of floor only.
- By using 2x45° elbow device the penetrating pipe may run horizontal on soffit in zero distance to basement ($s_3 > 0 \text{ mm}$)

Pipe :

- Material PE , type of pipe: Geberit Silent dB20
- Elbow connector 45°: Geberit Silent dB20 based on PE, electro-welding wire inside
- Pipe outside diameter is ($d_c = 110 \text{ mm}$)
- Pipe wall thickness thickness ($t_c = 6 \text{ mm}$)

Gap size and Gap filler:

- Refer to 3.4.1.2

Number of hooks for 2x45° elbow application:

- refer to 3.4.2.31.

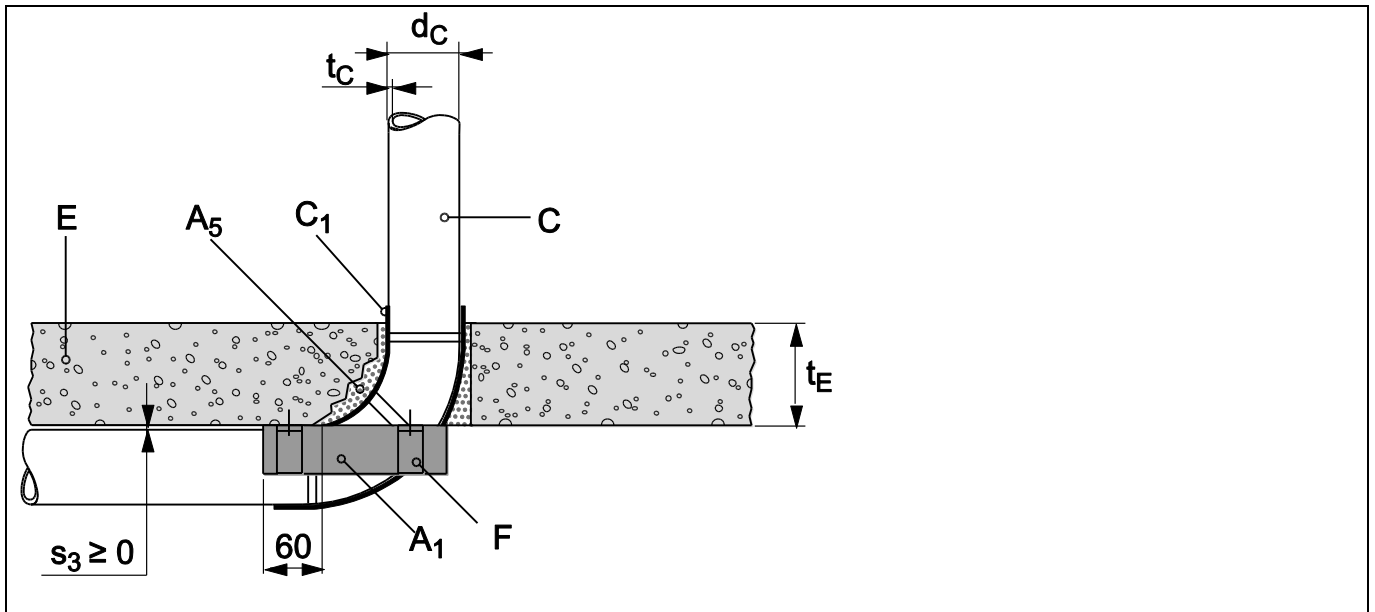

3.4.2.13B PE pipes, non-regulated (Geberit Silent dB20),

in rigid floor ($t_E \geq 150$ mm), pipe group 1, EI 120 - U/U

straight (90°), pipe coupling

Situation for Geberit Silent dB20 EI 120-U/U :

- Pipe coupling made of PE, with electric welding wire inside
- Perpendicular installation

Pipe :

- Material PE , type of pipe: Geberit Silent dB20
- Elbow connector 45°: Geberit Silent dB20 based on PE, electro-welding wire inside
- Pipe outside diameter is ($d_C = 110$ mm)
- Pipe wall thickness ($t_C = 6$ mm)

Gap size and Gap filler:

- Refer to 3.4.1.2

Number of hooks for pipe coupling application:

- refer to 3.4.2.34.

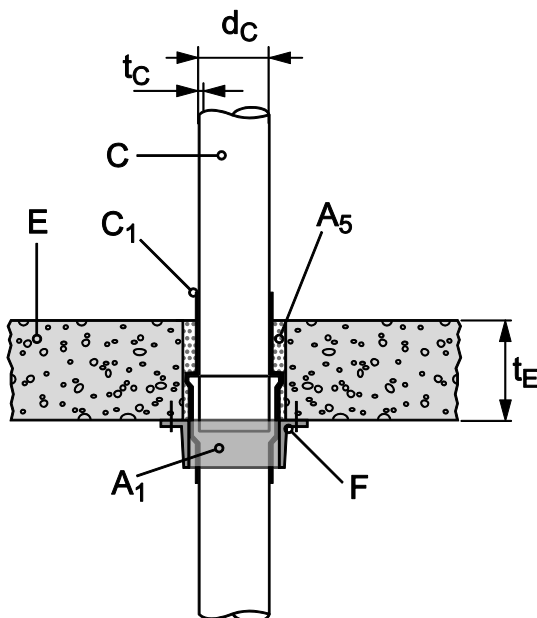

3.4.2.14 PE pipes acc. EN 1519-1, EN12201-2 and EN 12666-1,
in rigid floor ($t_E \geq 150$ mm), pipe group 2, EI 120 - U/U

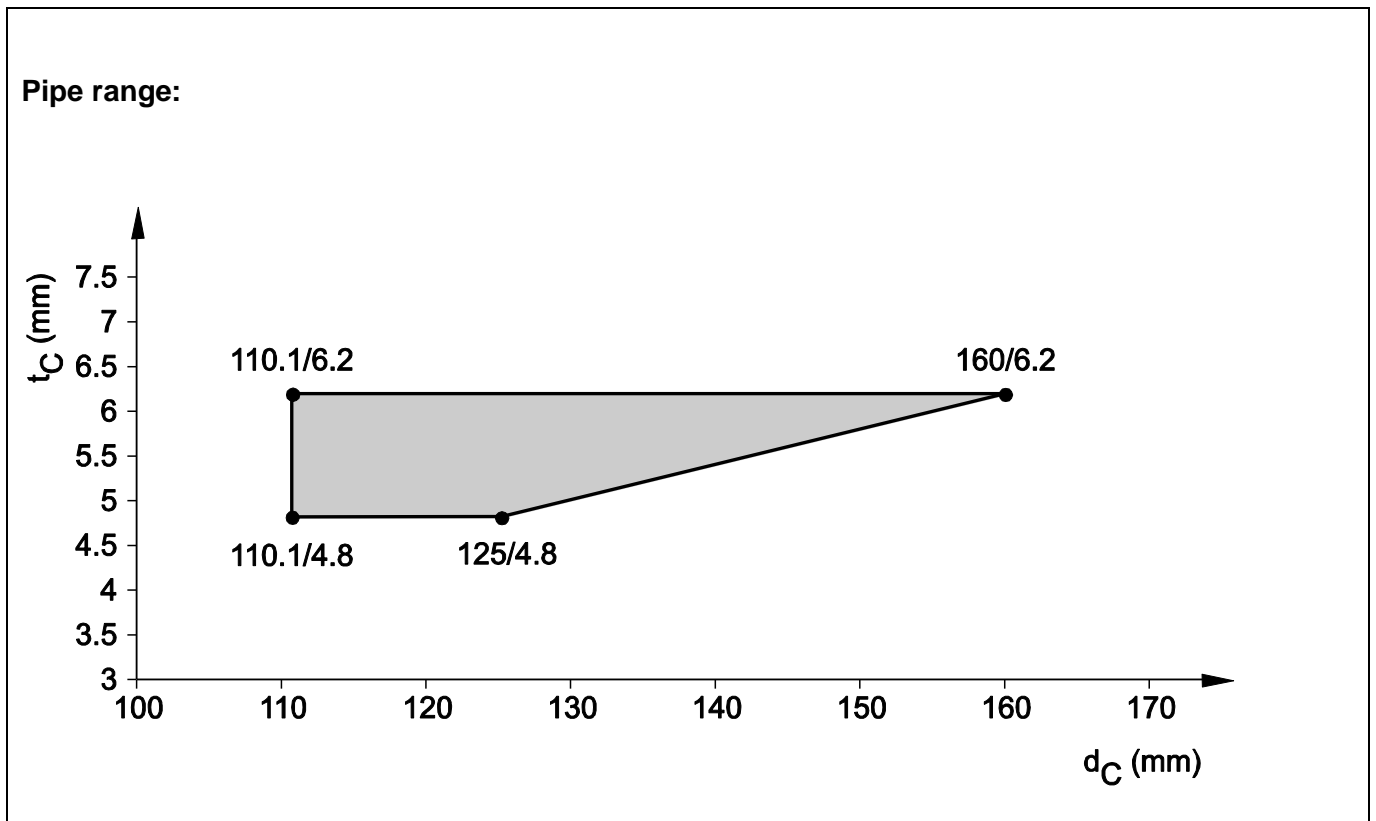

3.4.2.15 ABS pipes acc. EN 1455-1, EN 15493 and SAN+PVC-pipes acc. EN 1565-1,
in rigid floor ($t_E \geq 150$ mm), pipe group 2, EI 120 - U/U

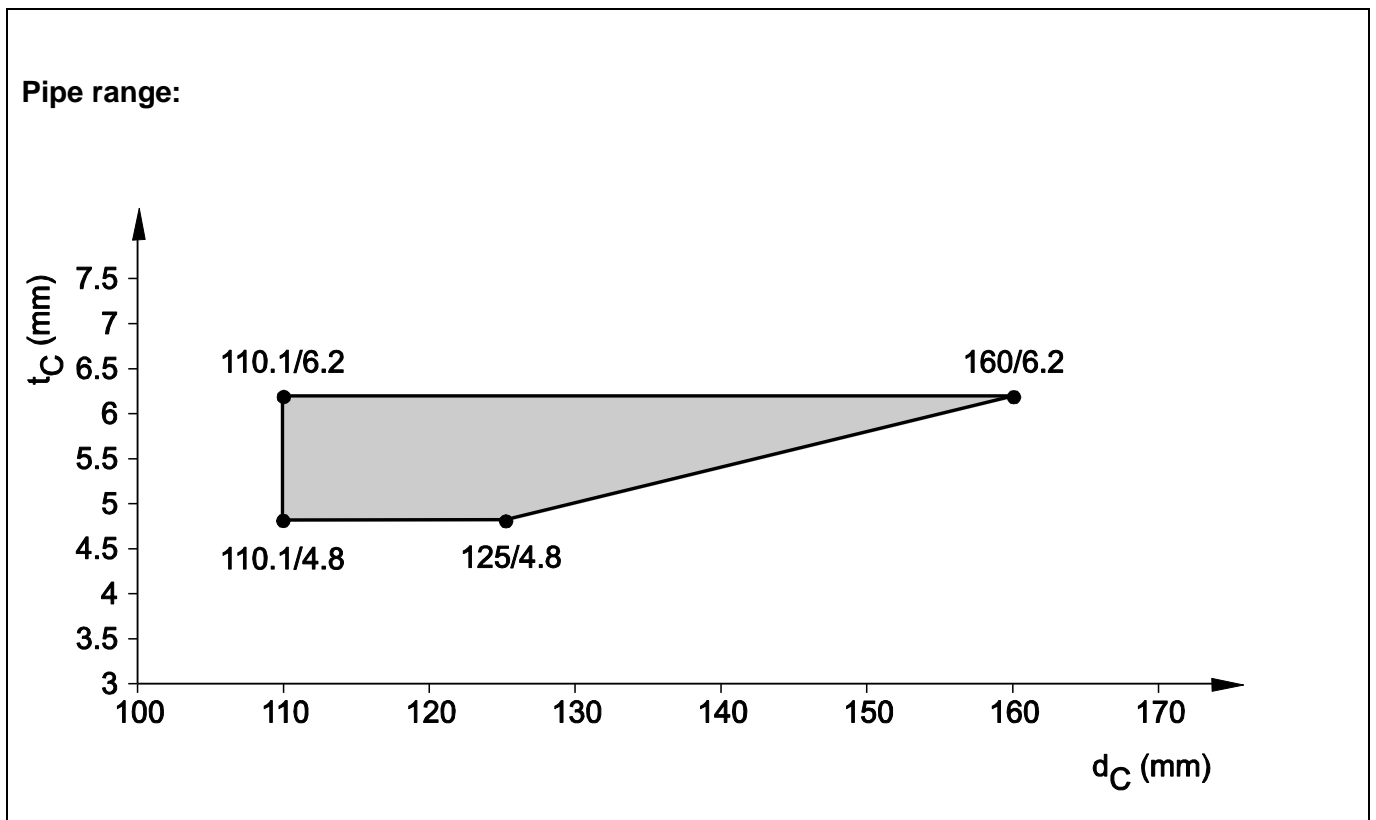

3.4.2.16 ABS pipes acc. EN 1455-1, EN 15493 and SAN+PVC-pipes acc. EN 1565-1,
in rigid floor ($t_E \geq 150$ mm), pipe group 2, EI 60 - U/U

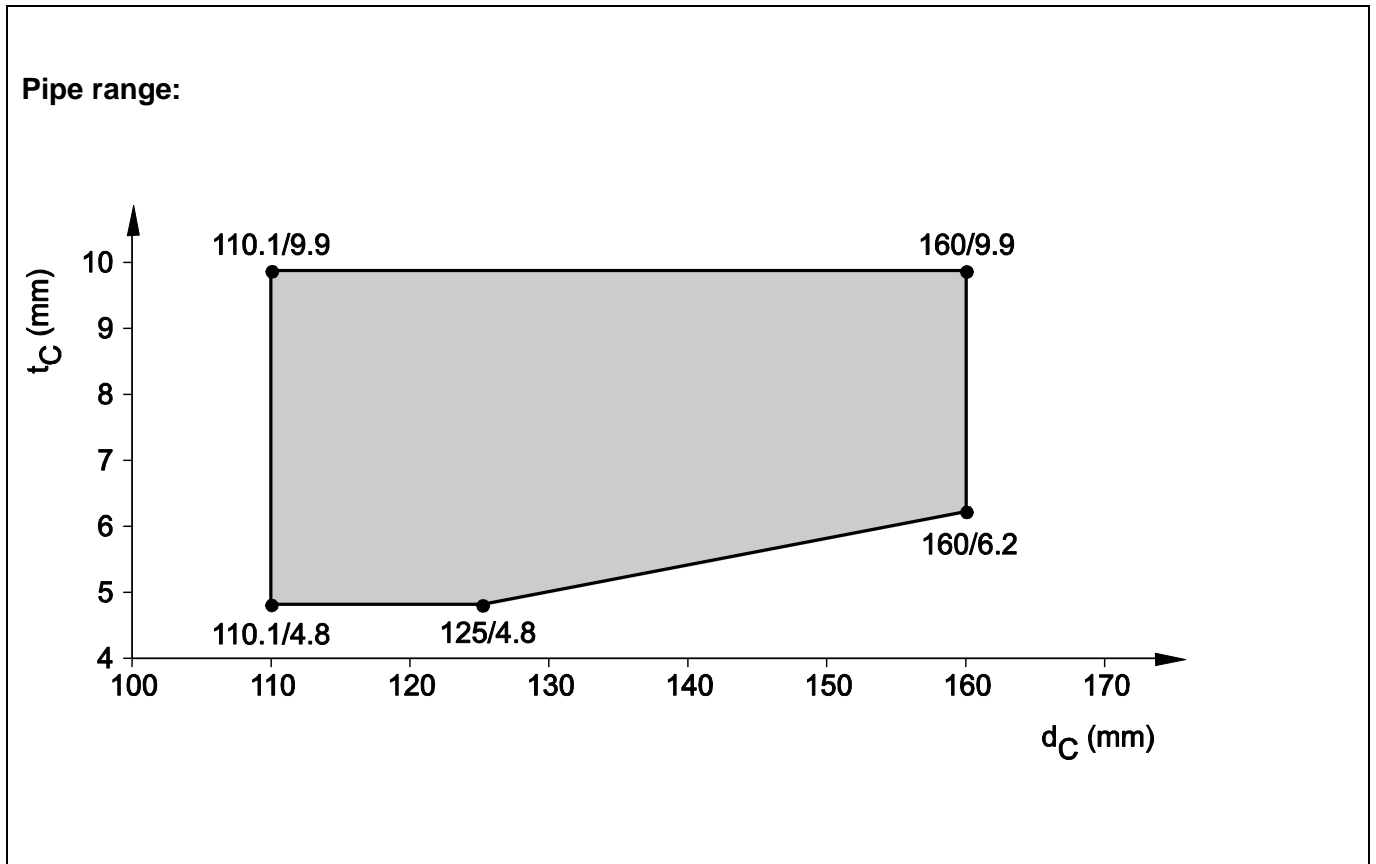

3.4.2.17 PE pipes acc. EN 15494, EN 12201-2 and DIN 8074/75,
in rigid floor ($t_E \geq 150$ mm), pipe group 2, EI 90 - U/U

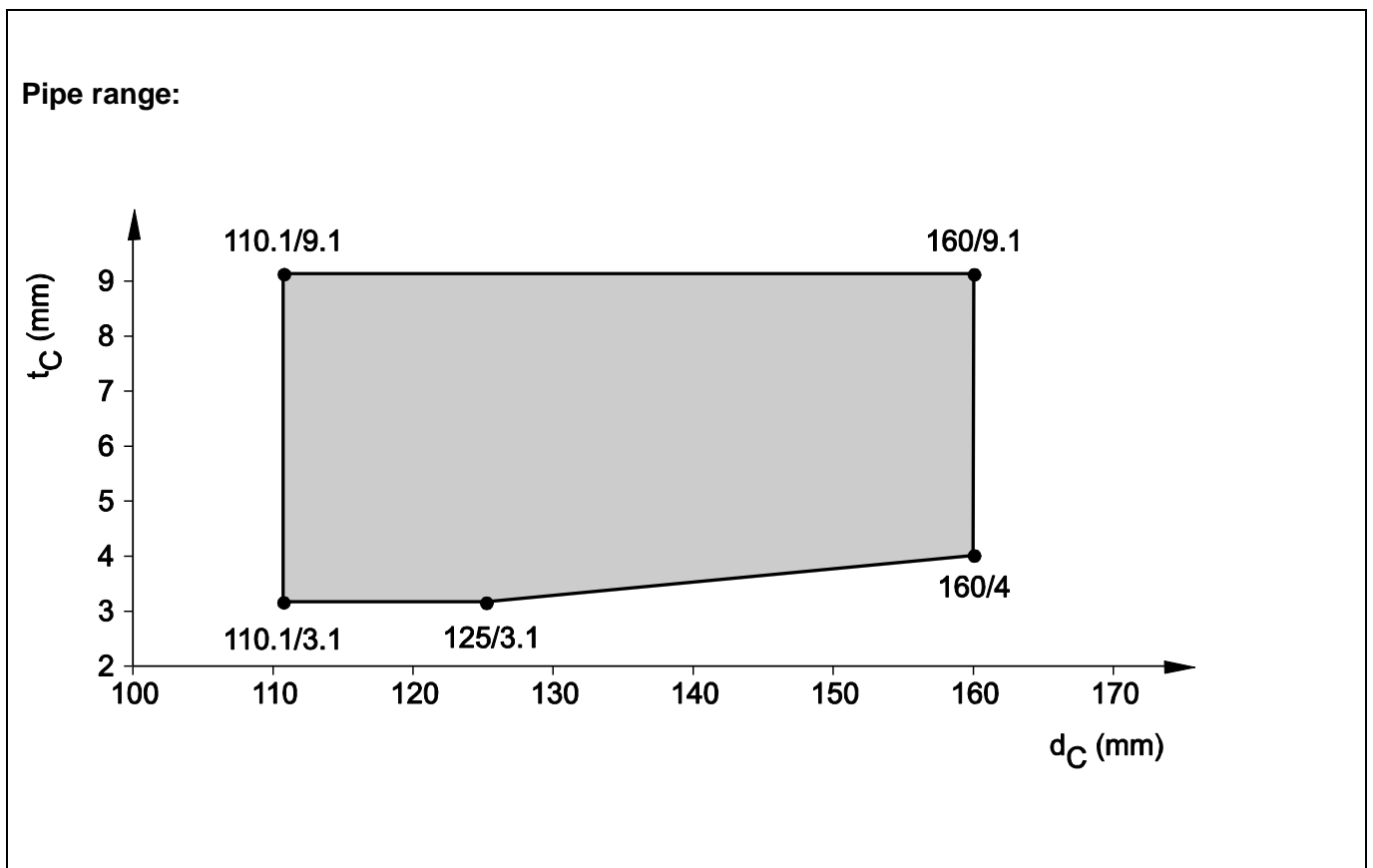

3.4.2.18 PE pipes acc. EN 15494, EN 12201-2 and DIN 8074/75,
in rigid floor ($t_E \geq 150$ mm), pipe group 2, EI 120 - U/C

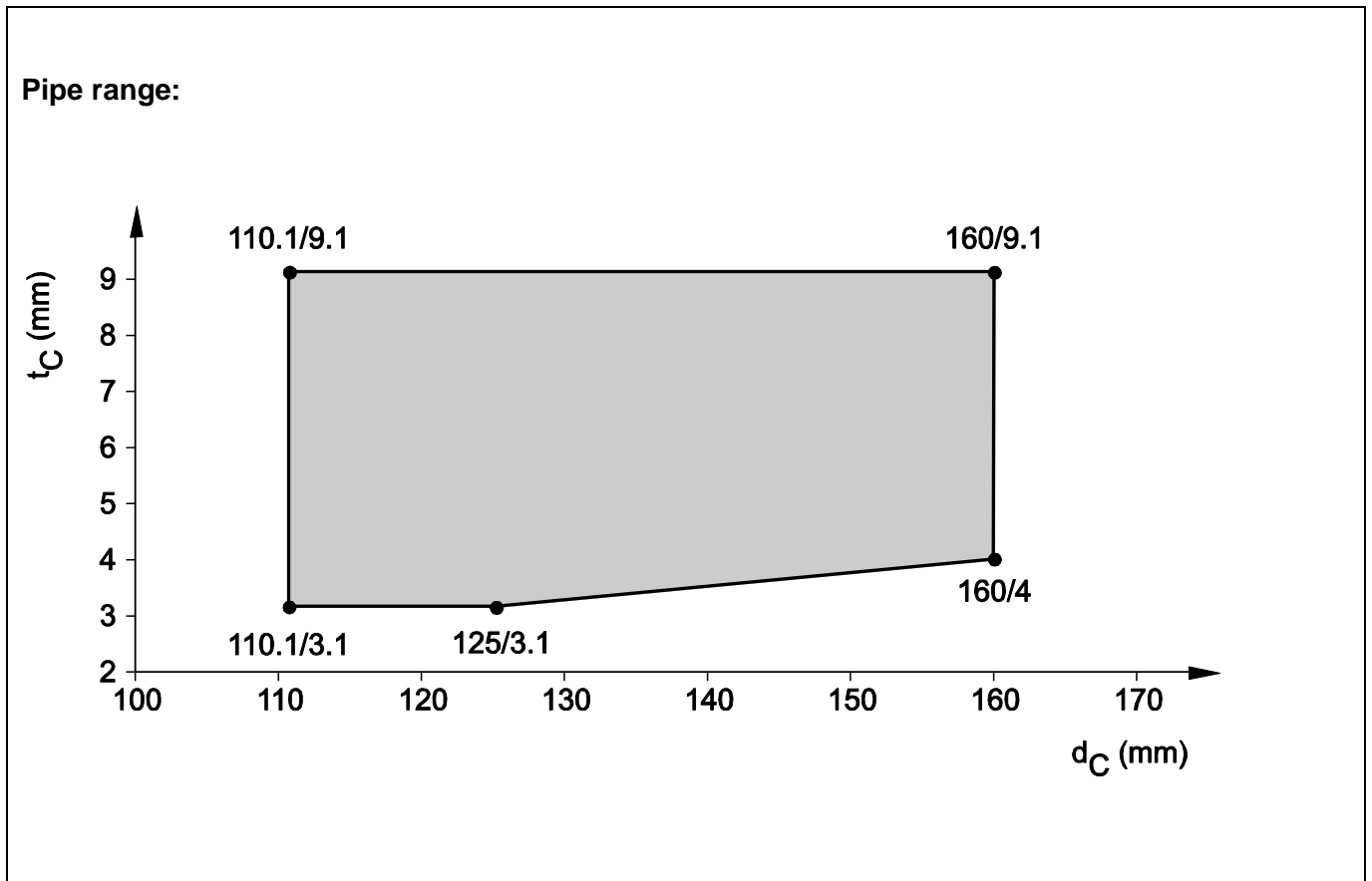

3.4.2.19 PE pipes acc. EN 15494, EN 12201-2 and DIN 8074/75,
in rigid floor ($t_E \geq 150$ mm), pipe group 2, EI 120 - U/U

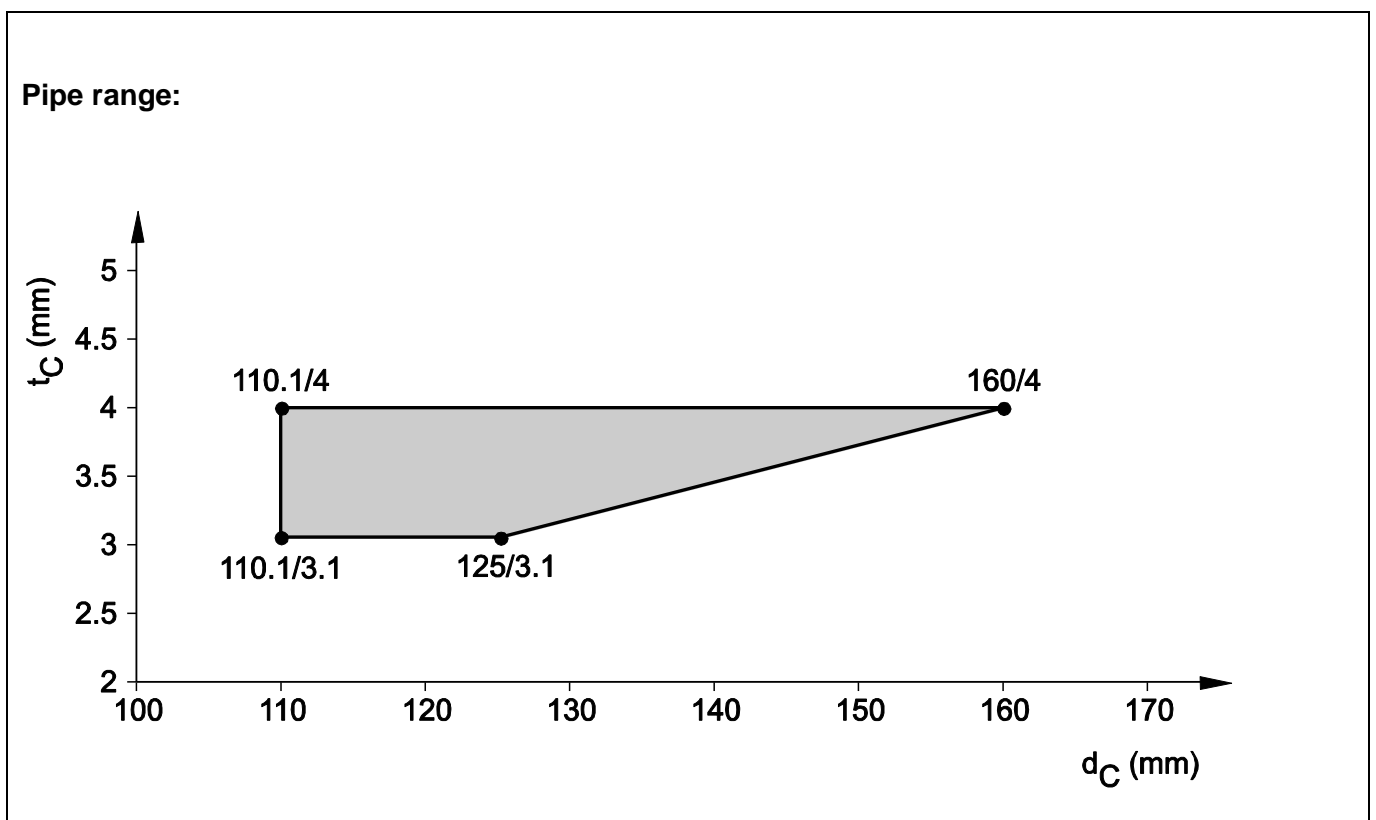

3.4.2.20 PVC pipes acc. EN 1452-1, EN 1453-1, EN 1566-1, EN 1329-1, EN ISO 15493 and DIN 8061/62, in rigid floor ($t_E \geq 150$ mm), pipe group 2, EI 90 - U/U

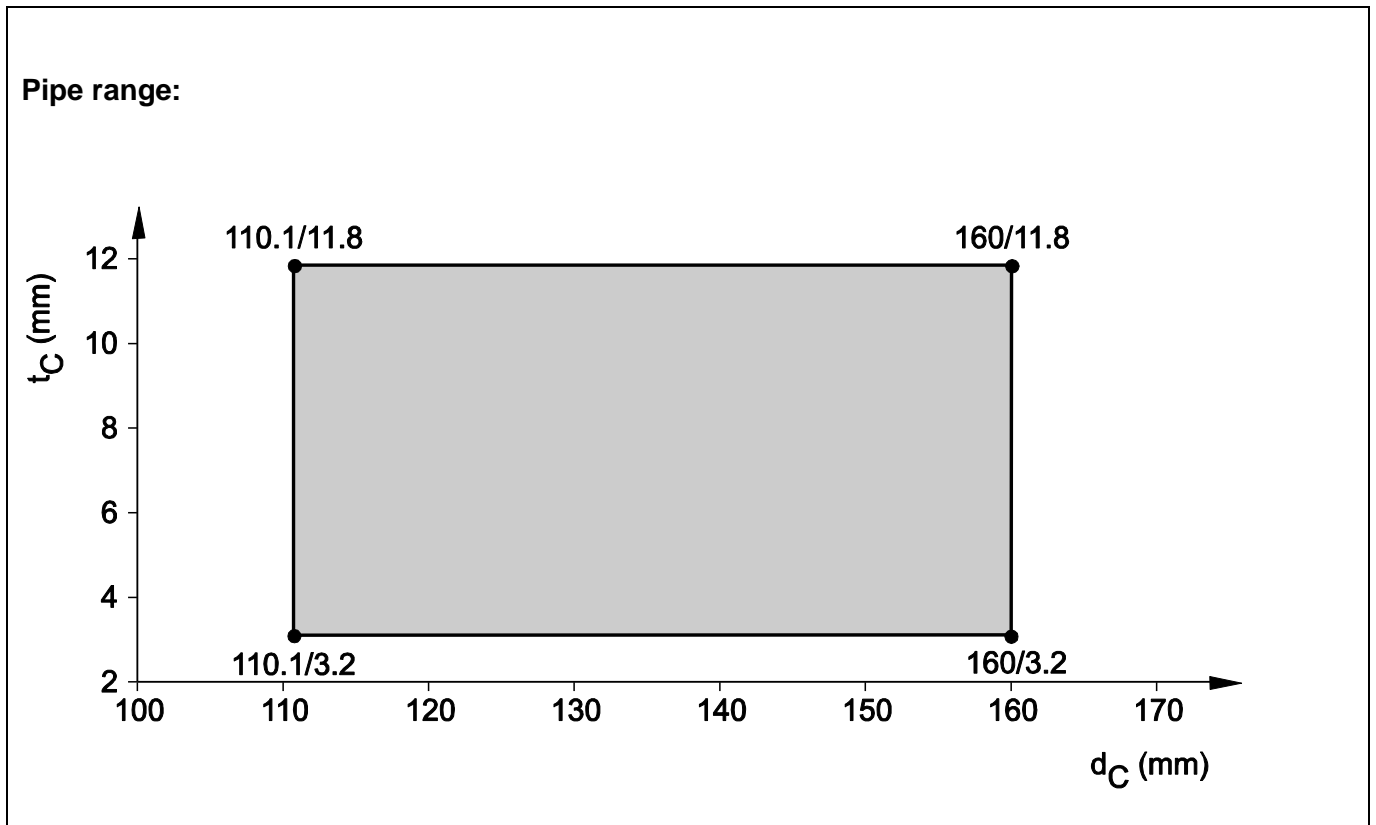

3.4.2.21 PP pipes, non-regulated, in rigid floor ($t_E \geq 150$ mm), pipe group 2, EI 120 - U/U

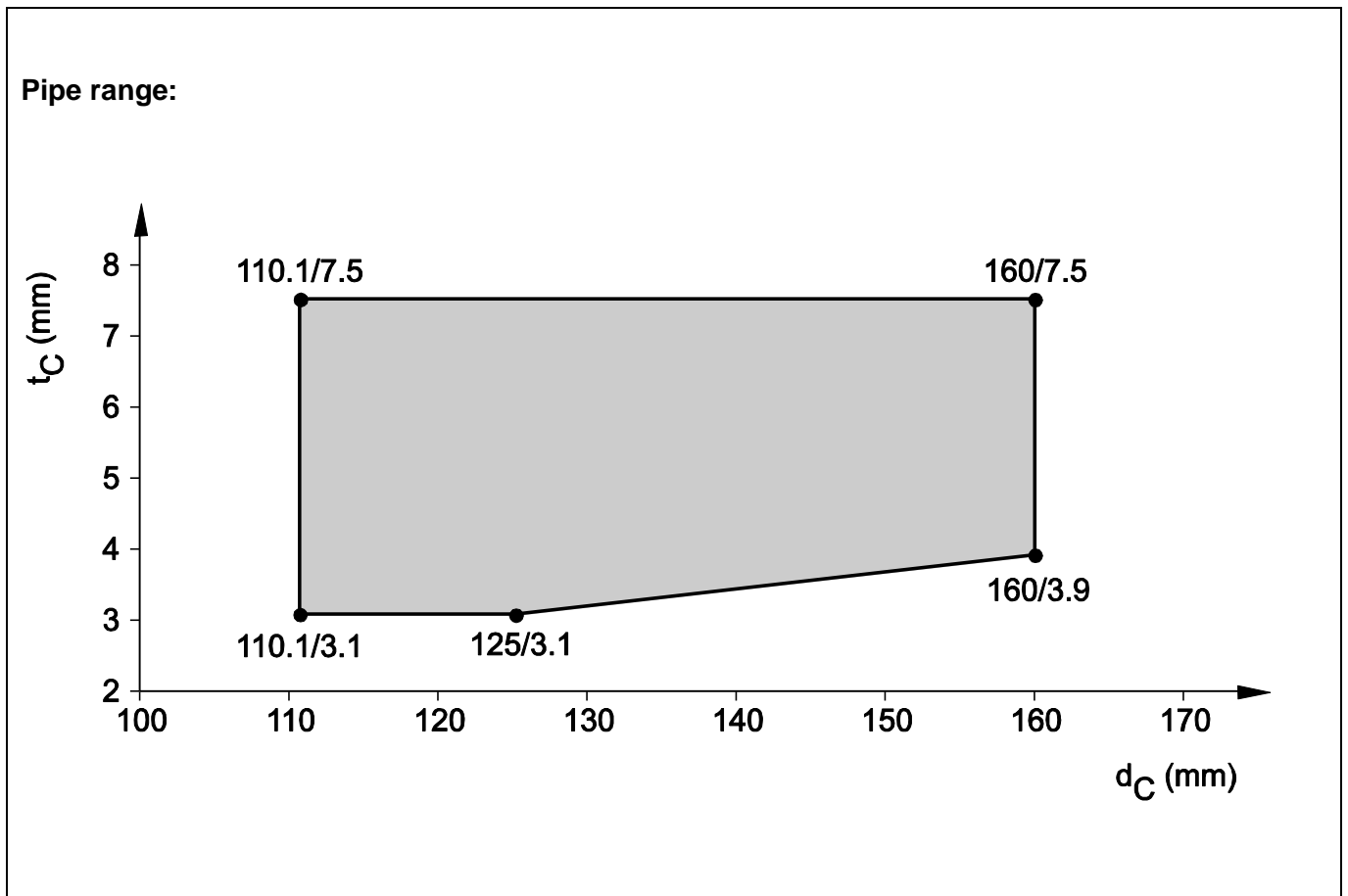

**3.4.2.22 PP pipes acc. EN 1451-1 and DIN 8077/78,
in rigid floor ($t_E \geq 150$ mm), pipe group 2 , EI 120 - U/U**

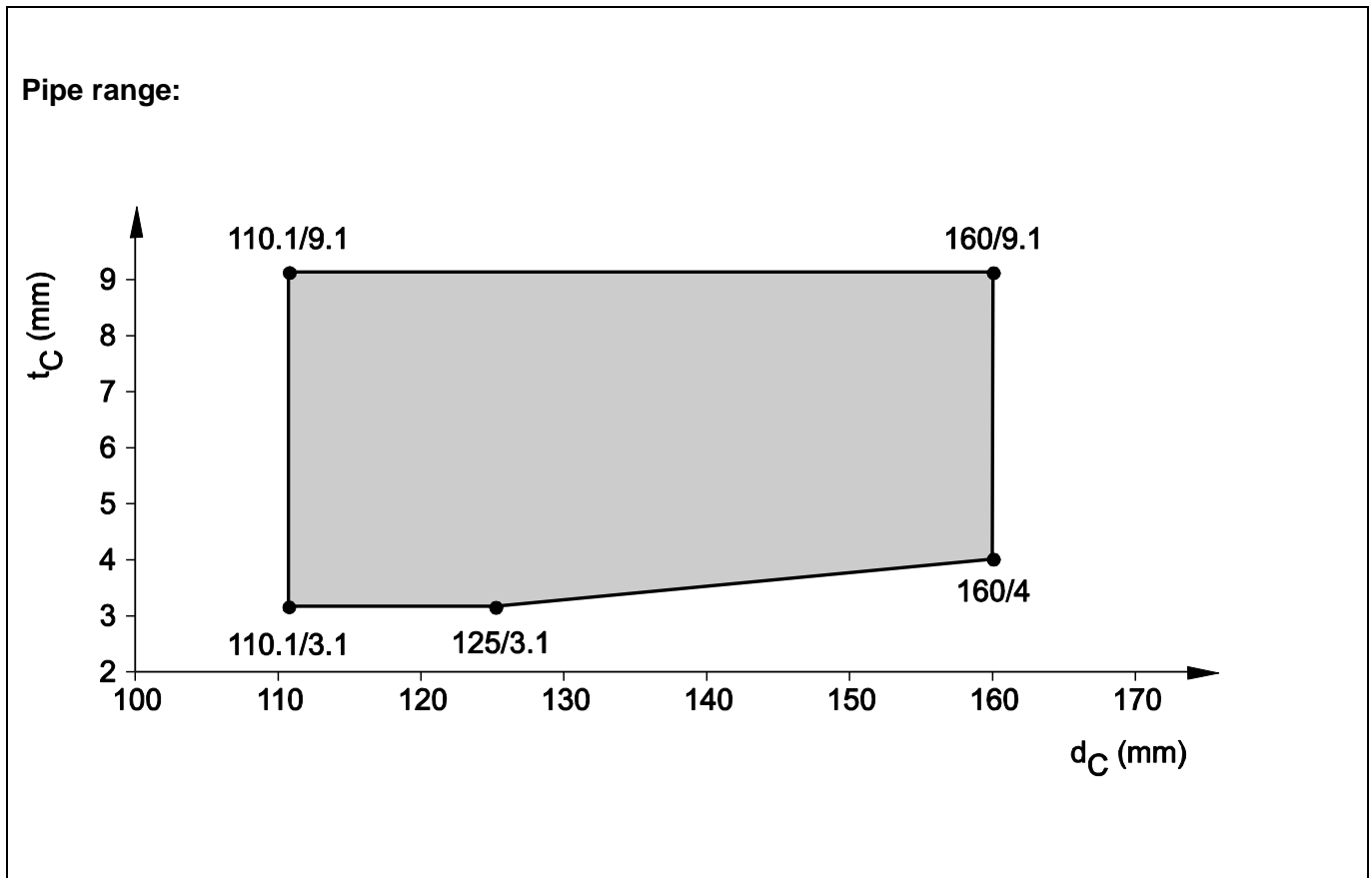

**3.4.2.21 Pneumatic dispatch system, PVC-U pipes acc. DIN 6660,
approved in rigid floor ($t_E \geq 150$ mm), pipe group 2 , EI 120 - U/U
straight (90°) installed**

Situation for EI 120-U/U:

- PVC pipe acc. DIN 6660
- Pipe diameter ($110,1 \leq d_C \leq 160$ mm)
- Pipe wall thickness ($t_C = 3,2$ mm)
- Pipe inclination : 90°
- Mixed penetration is allowed: pipe together with maximum three cables, see below
- Cable in direct contact to pipe (single or bunched cables allowed)

Maximum approved cable size is:

- NYM-J 3x2,5 mm²
- J-Y (St) Y 6 x 2 x 0,6 mm²
- 2 x 2,5 mm²

**3.4.2.24 PE pipes, non-regulated (Geberit Silent dB20),
in rigid floor ($t_E \geq 150$ mm), pipe group 2 , EI 120 - U/U**



Pipe range:

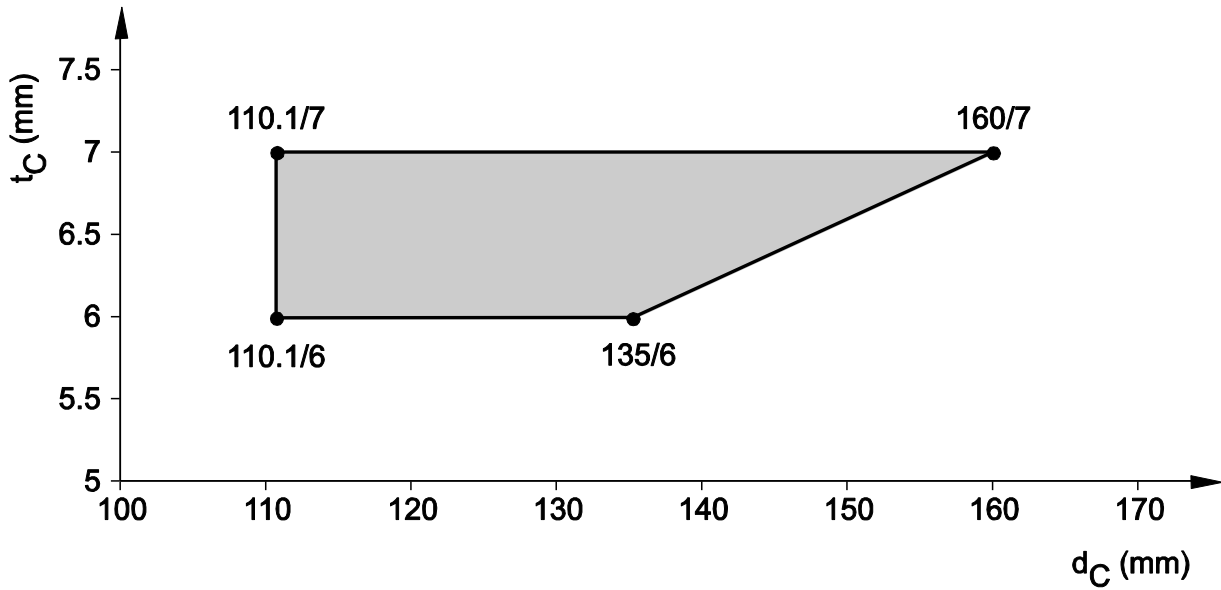

3.4.2.25 PVC pipes acc. EN 1452-1, EN 1329-1, EN 1453-1, EN 1566-1, EN ISO 15493 and DIN 8061/62, in rigid floor ($t_E \geq 150$ mm), pipe group 2, EI 120 - U/C situation

Pipe range:

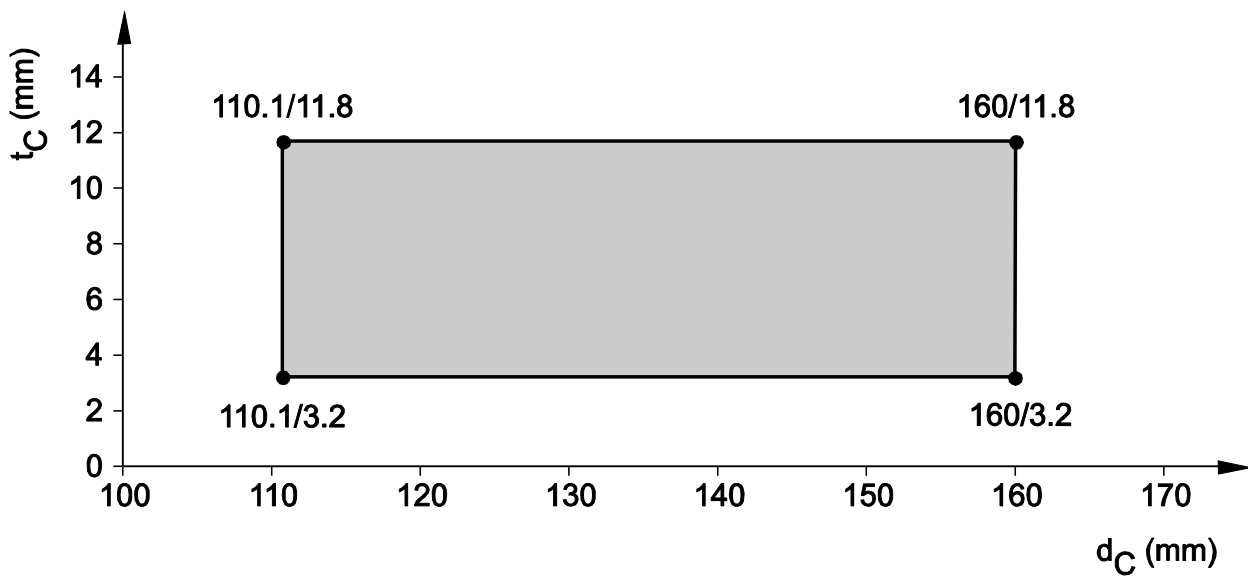

**3.4.2.26 PVC pipes, non-regulated (Friatec Friaphon)
in rigid floor ($t_E \geq 150$ mm), pipe group 2, EI 180 - U/U**

Pipe Range:

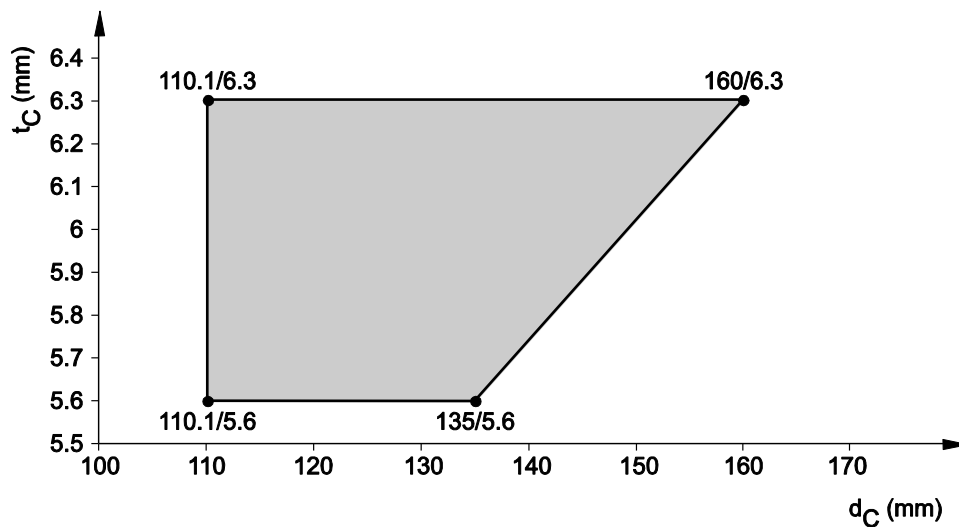

**3.4.2.27 PE-X - pipes acc. EN 15875 (Rehau Rautitan flex), insulated,
in rigid floor ($t_E \geq 150$ mm), pipe group 1 , EI 120 - U/C**

Situation for EI 120-U/U:

- PE-X acc. EN 15875 (Rehau Rautitan flex),
- Pipe diameter ($16 \text{ mm} \leq d_c \leq 32 \text{ mm}$)
- Pipe wall thickness ($2,2 \text{ mm} \leq t_c \leq 4,4 \text{ mm}$)
- Pipe inclination : 90°

Flexible, elastomeric thermal insulation D_E :

- Type of material: refer to 3.1.13
- Thickness of D_E : ($9 \text{ mm} \leq t_D \leq 25 \text{ mm}$)
- Insulation length: ($L_D \geq 250 \text{ mm}$) on pipes on both sides of the floor.
- LS/CS situation

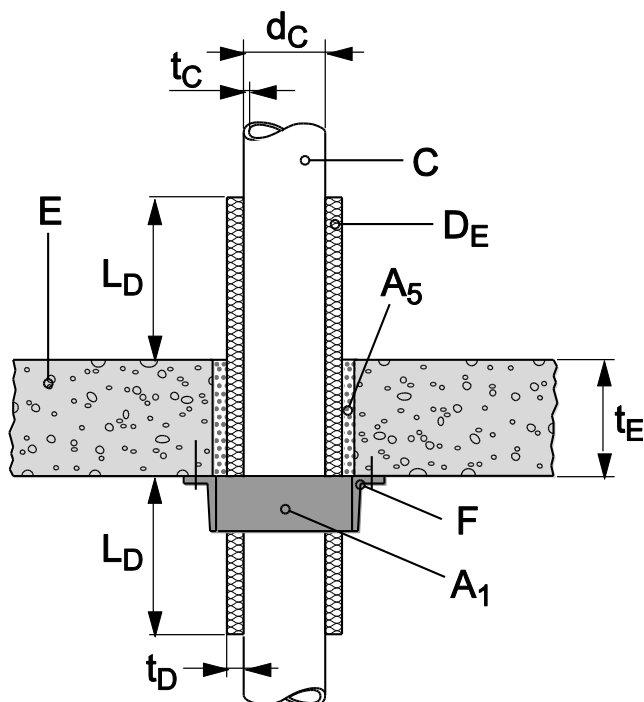

3.4.2.28 PP-R - pipes acc. EN 15874 (Aquatherm fusiolen =aquatherm green pipe S), insulated, in rigid floor ($t_E \geq 150$ mm), pipe group 1, EI 120 - U/C

Situation for EI 120-U/U:

- PP-R - pipes acc. EN 15874 Aquatherm fusiolen =aquatherm green pipe S,
- Pipe diameter ($16 \text{ mm} \leq d_c \leq 32 \text{ mm}$)
- Pipe wall thickness ($2,2 \text{ mm} \leq t_c \leq 4,4 \text{ mm}$)
- Pipe inclination : 90°

Flexible, elastomeric thermal insulation DE :

- Type of material: refer to 3.1.13
- Thickness of DE : ($9 \text{ mm} < t_D < 25 \text{ mm}$)
- Insulation length: ($L_D \geq 250 \text{ mm}$) on pipes on both sides of the floor.
- LS/CS situation

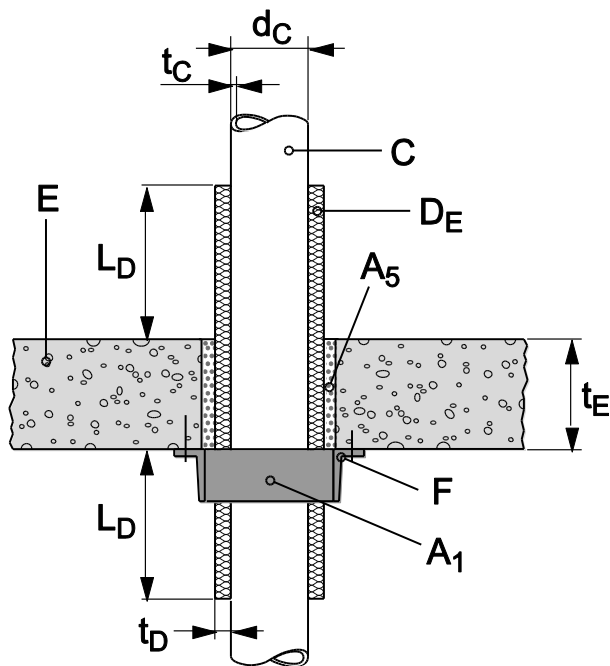

3.4.2.29 Multiple penetration, thermal insulated, in rigid floor ($t_E \geq 150$ mm), pipe group 1 , EI 120 - U/U and U/C

Situation for multiple pipes for EI 120 – U/C classification:

- One PE pipe acc. EN 1519-1, EN 12666-1, EN 12201-2 (U/U) in zero contact ($0 \text{ mm} \leq s_1 \leq 15 \text{ mm}$) together with
- One or two pipes acc. EN 15874 or EN 15875 (pipe material PP-R or PE-X) (U/C)
- The pipes acc. EN 15874 or EN 15875 are insulated with an elastomeric foamed thermal insulation
- Collar CFS-C EL covers the two or three pipes together within **one** bigger jacket.

PE pipe acc. EN 1519-1, EN 12666-1, EN 12201-2 (U/U):

- Pipe outside diameter is ($40 \text{ mm} \leq d_c \leq 90 \text{ mm}$)
- Pipe wall thickness thickness ($t_c = 3,5 \text{ mm}$)
- With or without sound decoupling isolation (for type, thickness and situation refer to 3.1.6)

PP-R or PE-X pipes acc. EN 15874 and EN 15875 (U/C):

- Pipe outside diameter is ($d_c = 40 \text{ mm}$)

- Pipe wall thickness thickness ($t_c = 5,5 \text{ mm}$)
- Type of pipes: Aquatherm fusiolen =aquatherm green pipe S and Rehau Rautitan flex

Elastomeric foamed thermal insulation:

- For material type refer to 3.1.13
- Approved insulation thickness is ($9 \text{ mm} \leq t_D \leq 32$) mm
- Approved installation situation is LS and CS
- Minimum insulation length ($L_D \geq 250 \text{ mm}$) on both sides of the floor

Collar fixing:

- For number of hooks refer to 3.1.4 and Tab.3, for fixing the hooks refer to 3.1.3.

View from above:

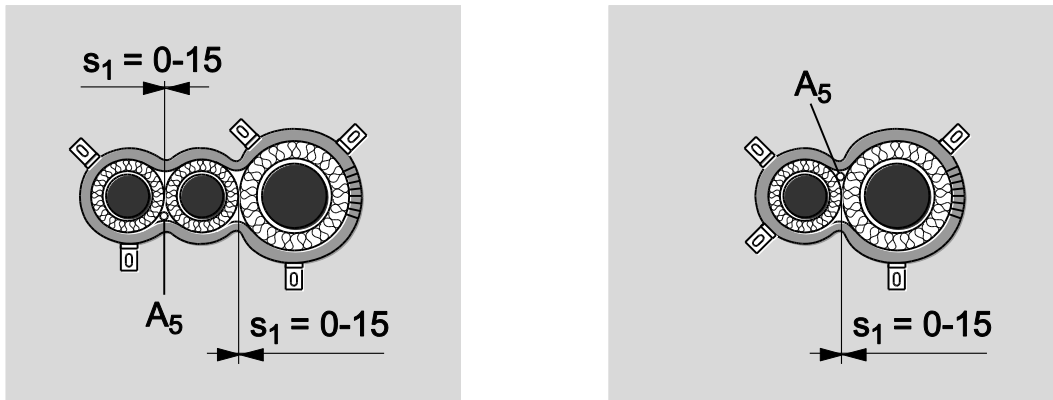

3.4.2.30 Reuse of oddments of CFS-C EL,

in rigid floor ($t_E \geq 150 \text{ mm}$), pipe group 1 and 2, EI 120 - U/U

Situation:

- reuse of oddments EI 120 - U/U for pipe group 1
- reuse of oddments EI 120 - U/U for pipe group 2

Pipe material and pipe range:

- For pipe group 1 – refer to 3.4.2.1; 3.4.2.2; 3.4.2.3; 3.4.2.4; 3.4.2.6; 3.4.2.7, 3.4.2.10, 3.4.2.11
- For pipe group 2 - refer to 3.4.2.14; 3.4.2.15; 3.4.2.19; 3.4.2.21; 3.4.2.22; 3.4.2.24; 3.4.2.26

Excluded from approved pipe range (PG1) are pipes with outside nominal diameter ($d_C > 110 \text{ mm}$).

Installation details

- For installation details – refer to 3.1.7

Number of hooks:

- For number of hooks – refer to 3.1.4 and 3.1.7

3.4.2.31 Hooks fixed in wet mortar for CFS-C EL,

in rigid floor ($t_E \geq 150 \text{ mm}$), pipe group 1 and 2, EI 120 – U/U

Situation:

- reuse of oddments EI 120 - U/U for pipe group 1
- reuse of oddments EI 120 - U/U for pipe group 2

Pipe material and pipe range:

- For pipe group 1 – refer to 3.4.2.1; 3.4.2.2; 3.4.2.3; 3.4.2.4; 3.4.2.6; 3.4.2.7, 3.4.2.10, 3.4.2.11
- For pipe group 2 - refer to 3.4.2.14; 3.4.2.15; 3.4.2.19; 3.4.2.21; 3.4.2.22; 3.4.2.24; 3.4.2.26

Excluded from approved pipe range (PG1) are pipes with outside nominal diameter ($d_c > 110$ mm).

Installation details

- For installation details – refer to 3.1.3

Number of hooks:

For number of hooks – refer to 3.1.

3.4.2.32 All pipes named in

3.4.2.1; 3.4.2.2; 3.4.2.3; 3.4.2.4; 3.4.2.5; 3.4.2.6; 3.4.2.7; 3.4.2.8; 3.4.2.10; 3.4.2.11;

in rigid floor ($t_E \geq 150$ mm), pipe group 1, EI 90 - U/U, Inclined Pipes 45°

Situation for EI 90-U/U:

- Pipe inclination ($45^\circ \leq \text{inclination} \leq 90^\circ$)

Pipe range and pipe material:

- refer to 3.4.2.1; 3.4.2.2; 3.4.2.3; 3.4.2.4; 3.4.2.5; 3.4.2.6; 3.4.2.7; 3.4.2.8; 3.4.2.10; 3.4.2.11
- Excluded are only pipes with an outside nominal diameter ($d_c > 110$ mm) .

Gap size and Gap filling:

- Gap filler: Hilti CFS-S ACR
- Annular Gap: 0 – 15 mm
- Depth t_{A2} to filled with Hilti CFS-S ACR: ($t_{A2} \geq 25$ mm)
- No backfilling required
- or**
- Gap filler: Hilti CFS-S ACR
- Annular Gap: 0 – 40 mm
- Depth t_{A2} to filled with Hilti CFS-S ACR: ($t_{A2} \geq 25$ mm) on the upper side of the floor only
- Backfilling required, refer to Annex 2, chapter 2.2
- or**
- Gap filler: cementious Mortar M10 acc. EN 998-2
- Annular Gap: 0 – 40 mm
- Depth to fill with cementious Mortar M10: to fill over entire floor thickness

Number of hooks:

Pipe outside nominal diameter d_c (mm)	Acoustic Pipe Insulation Thickness t_D (mm)		
	identical on both sides of the flexible wall/rigid wall		
	0	4	9
32	3	3	3
50	3	3	3

75	3	4	4
90	4	4	5
110	5	5	5

If pipe insulation thickness is between 0 and 4 mm use the number of hooks indicated for 4 mm.
If pipe insulation thickness is between 4 and 9 mm use the number of hooks indicated for 9 mm.

3.4.2.33 All PP pipes non-regulated,

in rigid floor ($t_E \geq 150$ mm), pipe group 1, EI 120 - U/U, elbow pipes 87°

Situation for EI 120-U/U :

- Elbow connector (87°) for non-regulated PP pipes
- Elbow connector (87°) installed inside the wall or partly inside the wall, sealed with Collar CFS-C EL
- On one side the pipe may run parallel to the floor having a zero distance to wall ($s_3 \geq 0$ mm).

Pipe range and pipe material:

- For pipe range - refer to 3.4.2.6
- For pipe material – refer to 3.1.15

Gap size and Gap filling:

- Gap filler: Hilti CFS-S ACR
- Annular gap: 0 – 15 mm
- Depth t_{A2} to filled with Hilti CFS-S ACR: ($t_{A2} \geq 25$ mm)
- No backfilling required
- **or**
- Gap filler: Hilti CFS-S ACR
- Annular gap: 0 – 40 mm
- Depth t_{A2} to filled with Hilti CFS-S ACR: ($t_{A2} \geq 25$ mm) on the upper side of the floor only
- Backfilling required, refer to Annex 2, chapter 2.2
- **or**
- Gap filler: cementious Mortar M10 acc.EN 998-2
- Annular gap: 0 – 40 mm
- Depth to fill with cementious Mortar M10: to fill over entire floor thickness

Collar fixing:

- Refer to 3.1.3

Number of hooks:

Pipe outside nominal diameter d_c (mm)	Acoustic Pipe Insulation Thickness t_D (mm)		
	(no elbow side - vertical running pipe / elbow side - horizontal running pipe)		
	0	4	9
32	2 / 2	2 / 2	2 / 2
50	2 / 2	2 / 2	2 / 3
75	3 / 3	3 / 3	3 / 3
90	3 / 3	3 / 3	3 / 3

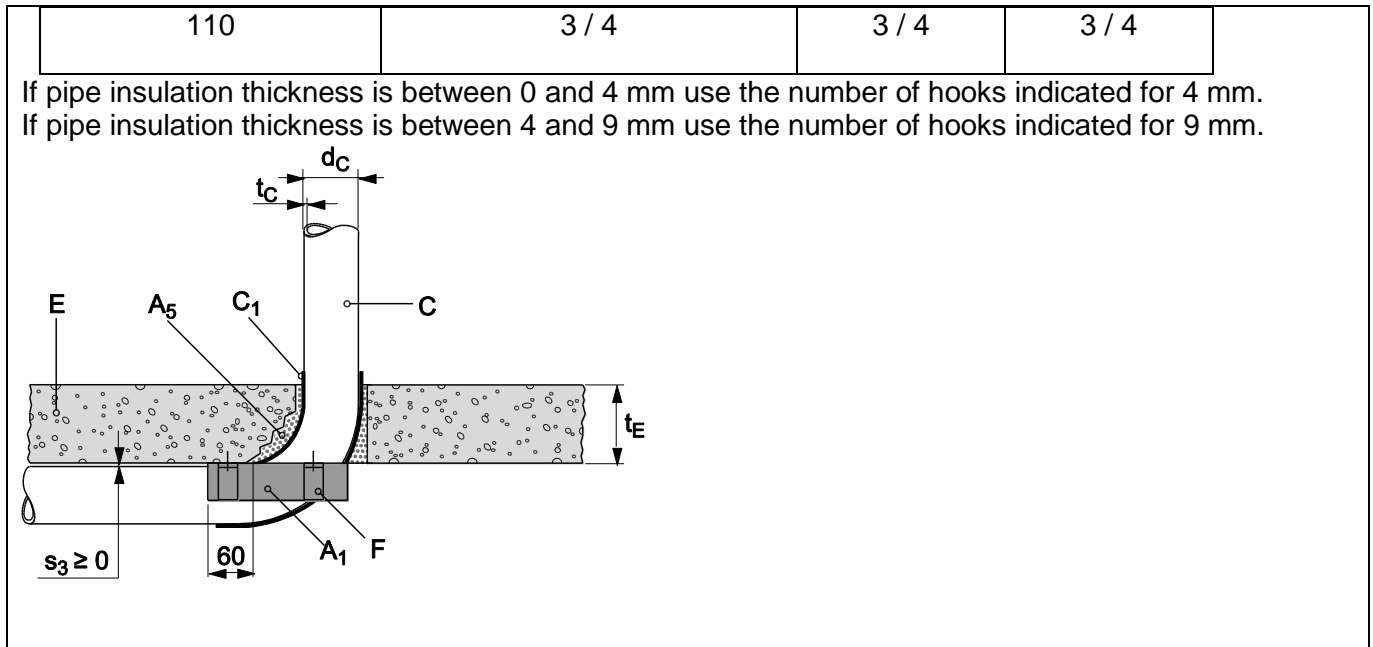

3.4.2.34 All PP pipes non-regulated,

in rigid floor ($t_E \geq 150$ mm), pipe group 1, EI 120 - U/U, elbow pipes 2 x 45°

Situation for EI 120-U/U:

- Elbow connector (2 pieces each of 45°) for non-regulated PP pipes
- Elbow installed inside the wall or partly inside the wall, sealed with Collar CFS-C EL
- On one side the pipe may run parallel to the floor having a zero distance to floor ($s_3 \geq 0$ mm).

Pipe range and material:

- For pipe range – refer to 3.4.2.6
- For pipe material – refer to 3.1.15

Gap size and Gap filling:

- Gap filler: Hilti CFS-S ACR
- Annular gap: 0 – 15 mm
- Depth t_{A2} to filled with Hilti CFS-S ACR: ($t_{A2} \geq 25$ mm)
- No backfilling required
- **or**
- Gap filler: Hilti CFS-S ACR
- Annular gap: 0 – 40 mm
- Depth t_{A2} to filled with Hilti CFS-S ACR: ($t_{A2} \geq 25$ mm) on the upper side of the floor only
- Backfilling required, refer to Annex 2, chapter 2.2
- **or**
- Gap filler: cementious Mortar M10 acc. EN 998-2
- Annular gap: 0 – 40 mm
- Depth to fill with cementious Mortar M10: to fill over entire floor thickness

Number of hooks:

Pipe outside nominal diameter d_C (mm)	Acoustic Pipe Insulation Thickness t_D (mm)		
	(no elbow side - horizontal running pipe / elbow side - vertical running pipe)		
	0	4	9
32	2 / 2	2 / 2	2 / 2
50	2 / 2	2 / 2	2 / 3

75	3 / 3	3 / 3	3 / 3
90	3 / 3	3 / 3	3 / 3
110	3 / 4	3 / 4	3 / 4

If pipe insulation thickness is between 0 and 4 mm use the number of hooks indicated for 4 mm.
If pipe insulation thickness is between 4 and 9 mm use the number of hooks indicated for 9 mm.

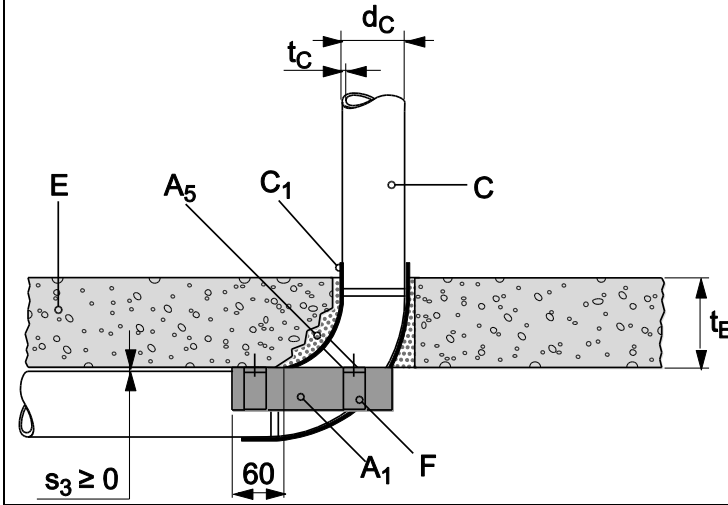

3.4.2.35 All pipes named in

3.4.2.1; 3.4.2.2; 3.4.2.3; 3.4.2.4; 3.4.2.5; 3.4.2.6; 3.4.2.7; 3.4.2.8; 3.4.2.10; 3.4.2.11;

in rigid floor ($t_E \geq 150$ mm), pipe group 1, EI 90 - U/U,

Pipe in the corner application – zero distance to two walls

Situation for EI 90 – U/U:

- Pipes directly mounted in the corner,
- Zero distance ($s_3 \geq 0$ mm) pipe to two walls at same time,
- Collar CFS-C EL cannot completely cover the circumference of sealed pipe.

Pipe range:

- For pipe material – refer to 3.4.2.1; 3.4.2.2; 3.4.2.3; 3.4.2.4; 3.4.2.5; 3.4.2.6; 3.4.2.7; 3.4.2.8; 3.4.2.10; 3.4.2.11
- For pipe dimension - refer to 3.4.2.1; 3.4.2.2; 3.4.2.3; 3.4.2.4; 3.4.2.5; 3.4.2.6; 3.4.2.7; 3.4.2.8; 3.4.2.10 ; 3.4.2.11

Excluded from approved pipe range are pipes with outside nominal diameter ($d_c > 110$ mm).

Gap size and Gap filler:

With CFS-S ACR:

- Gap size is 0 to 15 mm
- Gap filler is CFS-S ACR
- Installation depth: ($t_{A3} \geq 25$ mm) on each side of the floor
- No backfilling

or

- Gap size is 0 to 40 mm
- Gap filler is CFS-S ACR
- Installation depth: ($t_{A3} \geq 25$ mm) on the upper side of the floor only
- Backfilling with mineral wool, refer to Annex 2, chapter 2.2

With cementitious mortar:

- Gap size is (0 to 40 mm)
- Gap filler is mortar group M10 acc. EN 998-2

- Installation depth: over the entire thickness of the floor

Number of hooks:

- For number of hooks – refer to 3.1.4

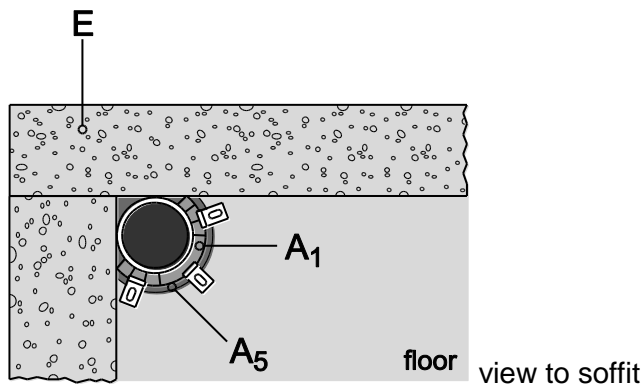

3.4.2.36 All pipes named in

3.4.2.1; 3.4.2.2; 3.4.2.3; 3.4.2.4; 3.4.2.5; 3.4.2.6; 3.4.2.7; 3.4.2.10; 3.4.2.11

in rigid floor ($t_E \geq 150$ mm), , pipe group 1, EI 120 - U/U,

Pipe on the wall application – zero distance to one walls when penetrates the floor

Situation for EI 120 – U/U:

- Pipes directly mounted on the wall,
- Zero distance ($s_3 \geq 0$ mm) pipe to one wall
- Collar CFS-C EL cannot completely cover the circumference of sealed pipe

Pipe range:

- For pipe material – refer to 3.4.2.1; 3.4.2.2; 3.4.2.3; 3.4.2.4; 3.4.2.5; 3.4.2.6; 3.4.2.7; 3.4.2.10; 3.4.2.11
- For pipe dimension – refer to 3.4.2.1; 3.4.2.2; 3.4.2.3; 3.4.2.4; 3.4.2.6; 3.4.2.7; 3.4.2.10; 3.4.2.11

Excluded pipes with outside nominal diameter ($d_c > 110$ mm).

Gap size and Gap filler:

With CFS-S ACR:

- Gap size is 0 to 15 mm
- Gap filler is CFS-S ACR
- Installation depth: ($t_{A3} \geq 25$ mm) on each side of the wall
- No backfilling

Or

- Gap size is 0 to 40 mm
- Gap filler is CFS-S ACR
- Installation depth: ($t_{A3} \geq 25$ mm) on the upper side of the floor only
- Backfilling with mineral wool, refer to Annex 2, chapter 2.2.

With cementious mortar:

- Gap size is (0 to 40 mm)
- Gap filler is mortar group M10 acc. EN 998-2
- Installation depth: over the entire floor thickness

Number of hooks:

- For number of hooks – refer to 3.1.4

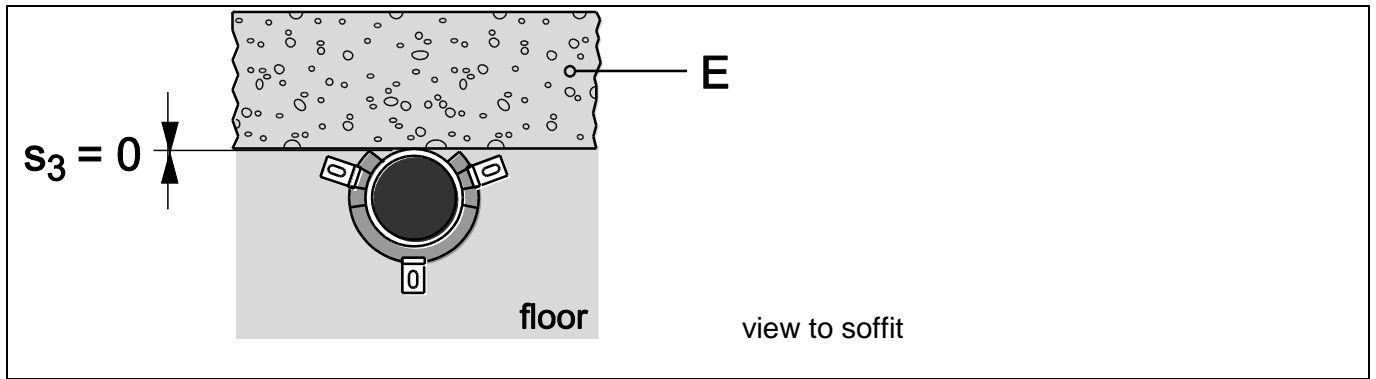

3.4.2.37 All PP pipes non-regulated, named in 3.4.2.6;

in rigid floor ($t_E \geq 150$ mm), pipe group 1, EI 120 - U/U, pipe coupling

Situation for EI 120 – U/U:

- Pipe coupling may be within the floor or directly below/above the floor
- Pipe coupling covered by CFS-C EL collar.

Pipe range:

- For pipe material – refer to 3.1.15
- For pipe dimension - refer to 3.4.2.6

Gap size and Gap filler:

With CFS-S ACR:

- Gap size is 0 to 15 mm
- Gap filler is CFS-S ACR
- Installation depth: ($t_{A3} \geq 25$ mm) on each side of the floor
- No backfilling

Or

- Gap size is 0 to 40 mm
- Gap filler is CFS-S ACR
- Installation depth: ($t_{A3} \geq 25$ mm) on the upper side of the floor only
- Backfilling with mineral wool, refer to Annex 2, chapter 2.2.4

With cementious mortar:

- Gap size is (0 to 40 mm)
- Gap filler is mortar group M10 acc. EN 998-2
- Installation depth: over the entire floor thickness

Number of hooks:

Pipe outside nominal diameter d_c (mm)	Acoustic Pipe Insulation Thickness t_D (mm)		
	(incoming pipe / outgoing pipe)		
	0	4	9
32	2 / 2	2 / 2	2 / 2
50	2 / 2	2 / 2	2 / 3
75	3 / 3	3 / 3	3 / 3
90	3 / 3	3 / 3	3 / 3

110	3 / 4	3 / 4	3 / 4
-----	-------	-------	-------

If pipe insulation thickness is between 0 and 4 mm use the number of hooks indicated for 4 mm.
If pipe insulation thickness is between 4 and 9 mm use the number of hooks indicated for 9 mm.

3.4.2.38 All pipes named in

3.4.2.1; 3.4.2.2; 3.4.2.3; 3.4.2.4; 3.4.2.6; 3.4.2.7; 3.4.2.10; 3.4.2.11

in rigid floor ($t_E \geq 150$ mm), pipe group 1, EI 120 - U/U,

Zero distance collar to collar application (in line)

Situation for EI 120-U/U (refer to 3.1.9) :

- Zero distance between two CFS-C EL collars, sealing two plastic pipes ($s_1 \geq 0$ mm)
 - Type of pipes: refer to 3.4.2.1; 3.4.2.2; 3.4.2.3; 3.4.2.4; 3.4.2.6; 3.4.2.7; 3.4.2.10; 3.4.2.11
 - Range of pipes: refer to 3.4.2.1; 3.4.2.2; 3.4.2.3; 3.4.2.4; 3.4.2.6; 3.4.2.7; 3.4.2.10; 3.4.2.11
- Excluded are only pipes with outside nominal diameter ($d_C > 110$ mm)
- Pipes have to be group in line
 - Number of pipes in line is unlimited

3.4.2.39 All pipes named in 3.4.2.14; 3.4.2.15; 3.4.2.19; 3.4.2.21; 3.4.2.22; 3.4.2.24; 3.4.2.26

in rigid floor ($t_E \geq 150$ mm), pipe group 2, EI 120 - U/U,

Zero distance collar to collar application (in line)

Situation for EI 120 - U/U (refer to 3.1.9) :

- Zero distance between two CFS-C EL collars, sealing two plastic pipes ($s_1 \geq 0$ mm)
- Type of pipes: refer to 3.4.2.14; 3.4.2.15; 3.4.2.19; 3.4.2.21; 3.4.2.22; 3.4.2.24; 3.4.2.26
- Range of pipes: refer to 3.4.2.14; 3.4.2.15; 3.4.2.19; 3.4.2.21; 3.4.2.22; 3.4.2.24; 3.4.2.26
- Pipes have to be group in line
- Number of pipes in line is unlimited

3.4.2.40 Zero distance CFS-C EL to mineralwool insulated pipes

3.4.2.40.1 All pipes named in 3.4.2.1; 3.4.2.2; 3.4.2.3; 3.4.2.4; 3.4.2.6; 3.4.2.7; 3.4.2.10; 3.4.2.11

rigid floor ($t_E \geq 150$ mm), pipe group 1, EI 120 - U/U,

Zero distance collar CFS-C EL to mineral wool thermal insulation on metal pipes

Situation for EI 120 - U/U (refer to 3.1.10.1):

- Collar CFS-C EL on plastic pipe in direct contact to mineral wool insulation ($s_1 > 0$ mm)
- Type of pipes: refer to 3.4.2.1; 3.4.2.2; 3.4.2.3; 3.4.2.4; 3.4.2.6; 3.4.2.7; 3.4.2.10; 3.4.2.11
- Range of pipes : refer to 3.4.2.1; 3.4.2.2; 3.4.2.3; 3.4.2.4; 3.4.2.6; 3.4.2.7; 3.4.2.10; 3.4.2.11

Excluded are only pipes with an outside nominal diameter ($d_c > 110$ mm).

- Used type of Insulation: refer to 3.1.10.1

Pipes diameter ($d_M \leq 42$ mm):

- Insulation thickness ($t_D \geq 19$ mm) within the flexible wall ($t_E = LD$)
- Insulation thickness ($t_D \geq 20$ mm) on metal pipes on both sides of the wall
- Insulation length $LD \geq 1000$ mm on both sides of the wall
- LS situation

Pipes diameter (42 mm $< d_M \leq 89$ mm):

- insulation thickness for mineral wool on metal pipes outside the floor: ($t_D \geq 30$ mm)
- insulation length below and above the floor : $L_D \geq 1000$ mm
- insulation thickness on metal pipe within the floor ($t_D \geq 20$ mm), $t_E = L_D$
- LS situation

Metal pipes, insulated by named above types of mineral wool products:

- pipe diameter ($d_M \leq$ of 42 mm)
- pipe wall thickness of ($1,2$ mm $\leq t_M \leq 14,2$ mm)
- Covered material types– refer to 3.1.12.

Gap size and Gap filler:

- Gap filler: Hilti CFS-S ACR
- Annular Gap: 0 – 15 mm
- Depth t_{A2} to filled with Hilti CFS-S ACR: ($t_{A2} \geq 25$ mm)
- No backfilling required

or

- Gap filler is CFS-S ACR
- Annular Gap : 0 - 40 mm
- Installation depth: ($t_{A2} \geq 25$ mm) on the upper side of the floor only
- Backfilling with mineral wool, refer to Annex 2, chapter 2.2.

or

- Gap filler: cementious Mortar M10 acc.EN 998-2
- Annular Gap: 0 – 40 mm
- Depth to fill with cementious Mortar M10: to fill over entire floor thickness

3.4.2.40.2 All pipes named in

3.4.2.1; 3.4.2.2; 3.4.2.3; 3.4.2.4; 3.4.2.6; 3.4.2.7; 3.4.2.10; 3.4.2.11

in rigid floor ($t_E \geq 150$ mm), pipe group 1, EI 120 - U/U,

Zero distance collar CFS-C EL to mineral wool thermal insulation on metal pipes

Situation for EI 120 - U/U (refer to 3.1.10.1):

- Collar CFS-C EL on plastic pipe in direct contact to mineral wool insulation ($s_1 > 0$ mm) on metal pipes
- Type of pipes: refer to 3.4.2.1; 3.4.2.2; 3.4.2.3; 3.4.2.4; 3.4.2.6; 3.4.2.7; 3.4.2.10; 3.4.2.11 Range of pipes : refer to 3.4.2.1; 3.4.2.2; 3.4.2.3; 3.4.2.4; 3.4.2.6; 3.4.2.7; 3.4.2.10; 3.4.2.11

Excluded are pipes with an outside nominal diameter ($d_c > 110$ mm).

- Used type of Insulation: refer to 3.1.10.1

Pipes diameter ($d_M \leq 42$ mm):

- Insulation thickness ($t_D \geq 19$ mm) within the flexible wall ($t_E = LD$)
- Insulation thickness ($t_D \geq 20$ mm) on metal pipes on both sides of the wall
- Insulation length $LD \geq 1000$ mm on both sides of the wall
- LS situation

Pipes diameter (42 mm $< d_M \leq 114,3$ mm):

- insulation thickness for mineral wool on metal pipes outside the floor: ($t_D \geq 30$ mm)
- insulation length below and above the floor : $L_D \geq 1000$ mm

- insulation thickness on metal pipe within the floor ($t_D \geq 30$ mm), $t_E = L_D$
- LS situation

Metal pipes, insulated by named above types of mineral wool products:

- pipe diameter ($d_M \leq$ of 114,3 mm)
- pipe wall thickness of ($1,2$ mm $\leq t_M \leq$ 14,2 mm)
- Covered material types– refer to 3.1.12., excluded material is copper

Gap size and Gap filler:

- Gap filler: Hilti CFS-S ACR
- Annular Gap: 0 – 15 mm
- Depth t_{A2} to be filled with Hilti CFS-S ACR: ($t_{A2} \geq 25$ mm)
- No backfilling required

or

- Gap filler is CFS-S ACR
- Annular Gap : 0 - 40 mm
- Installation depth: ($t_{A2} \geq 25$ mm) on the upper side of the floor only
- Backfilling with mineral wool, refer to Annex 2, chapter 2.2.

or

- Gap filler: cementious Mortar M10 acc. EN 998-2
- Annular Gap: 0 – 40 mm
- Depth to be filled with cementious Mortar M10: to fill over entire floor thickness

3.4.2.40.3 All pipes named in

3.4.2.1; 3.4.2.2; 3.4.2.3; 3.4.2.4; 3.4.2.6; 3.4.2.7; 3.4.2.10; 3.4.2.11

in rigid floor ($t_E \geq 150$ mm), pipe group 1, EI 120 - U/U,

Zero distance collar CFS-C EL to mineral wool thermal insulation on aluminium

composite pipes

Situation for EI 120 - U/U (refer to 3.1.10.2):

- Collar CFS-C EL on plastic pipe in direct contact to mineral wool insulation ($s_1 > 0$ mm) on aluminium
- Type of pipes: refer to 3.4.2.1; 3.4.2.2; 3.4.2.3; 3.4.2.4; 3.4.2.6; 3.4.2.7; 3.4.2.10; 3.4.2.11
- Range of pipes : refer to 3.4.2.1; 3.4.2.2; 3.4.2.3; 3.4.2.4;; 3.4.2.6; 3.4.2.7; 3.4.2.10; 3.4.2.11

Excluded are only pipes with an outside nominal diameter ($d_C > 110$ mm).

Mineral wool based thermal insulation

- Used type of Insulation: refer to 3.1.10.2
- insulation thickness: $t_D \geq 20$ mm and ≤ 60 mm
- insulation length: $L_D \geq 1000$ mm
- LS situation

Aluminium composite pipes, insulated by named above types of mineral wool products:

- See table below

Gap size and Gap filler:

- Gap filler: Hilti CFS-S ACR
- Annular Gap: 0 – 15 mm
- Depth t_{A2} to be filled with Hilti CFS-S ACR: ($t_{A2} \geq 25$ mm)
- No backfilling required

or

- Gap filler is CFS-S ACR

- Annular Gap : 0 - 40 mm
 - Installation depth: ($t_{A2} \geq 25$ mm) on the upper side of the floor only
 - Backfilling with mineral wool, refer to Annex 2, chapter 2.2.
- or**
- Gap filler: cementious Mortar M10 acc. EN 998-2
 - Annular Gap: 0 – 40 mm
 - Depth to be filled with cementious Mortar M10: to fill over entire floor thickness

Pipe Ø (mm)	Wall thickness (mm)	Pipe Insulation		
		Type	Thickness (mm)	Configuration (---)
Geberit Mepla – material: PE-Xb/Al/PE-Xb				
16 - 63	2,25 - 4,5	mineralwool	20 - 60	LS
Kekelit Kelox – material: PE-RT/Al/PE-RT				
16 - 63	2,0 - 6,0	mineralwool	20 - 60	LS
Rehau Rautitan Flex – material: PE-Xa – standard: EN 151875				
16 - 63	2,2 – 8,6	mineralwool	20 - 60	LS
TECEflex Verbundrohr – material: PE-Xc/Al/PE				
16 - 63	2,75 – 6,0	mineralwool	20 - 60	LS
Uponor Unipipe MLC – material: PE-RT/Al/PE-RT				
16 - 63	2,0 - 6,0	mineralwool	20 - 60	LS
Uponor Unipipe Plus – material: PE-RT/Al/PE-RT				
16 - 32	2,0 – 3,0	mineralwool	20 - 60	LS
Viega Raxofix – material: PE-Xc/Al/PE-Xc				
16 - 63	2,2 – 4,5	mineralwool	20 - 60	LS
Wavin Tigris – material: PE-Xc/Al/PE				
16 - 63	2,0 – 6,0	mineralwool	20 - 60	LS

3.4.2.41 Zero distance CFS-C EL to combustible insulated pipes

3.4.2.4.1 All pipes named in

3.4.2.1; 3.4.2.2; 3.4.2.3; 3.4.2.5; 3.4.2.6; 3.4.2.7; 3.4.2.8; 3.4.2.10; 3.4.2.11

in rigid floor ($t_E > 150$ mm), pipe group 1, EI 90 - U/U,

Zero distance collar CFS-C EL to Hilti CFS-B, used to seal an elastomeric thermal insulation on metal pipes

Situation for EI 90 - U/U (refer to 3.1.11) :

- Zero distance between CFS-C EL collar and CFS-B, wrapped around an elastomeric foamed thermal insulation on metallic pipe ($s_1 \geq 0$ mm)

- Type of pipes: refer to 3.4.2.1; 3.4.2.2; 3.4.2.3, 3.4.2.5; 3.4.2.6; 3.4.2.7; 3.4.2.8; 3.4.2.10; 3.4.2.11
- Range of pipes: refer to 3.4.2.1; 3.4.2.2; 3.4.2.3, 3.4.2.5; 3.4.2.6; 3.4.2.7; 3.4.2.8; 3.4.2.10; 3.4.2.11

Excluded are only pipes with outside nominal diameter ($d_C > 110$ mm) .

Flexible, elastomeric thermal insulation D_E :

- Type of material: refer to 3.1.13
- Thickness of D_E : ($9 \text{ mm} \leq t_D \leq 32 \text{ mm}$)
- Insulation length: ($L_D \geq 250 \text{ mm}$) on pipes on both sides of the floor.
- CS situation

Metal pipes:

- Pipe diameter ($15 \text{ mm} \leq d_M \leq 35 \text{ mm}$)
- Pipe wall thickness of ($1,0 \text{ mm} \leq t_M \leq 14,2 \text{ mm}$)
- Covered material types for metal pipes – refer to 3.1.12.

Gap size and gap filling:

- Gap filler: Hilti CFS-S ACR
- Annular gap: 0 – 15 mm
- Depth t_{A2} to filled with Hilti CFS-S ACR: ($t_{A2} \geq 25 \text{ mm}$)
- No backfilling required
- **or**
- Gap filler: Hilti CFS-S ACR
- Annular gap: 0 – 40 mm
- Depth t_{A2} to filled with Hilti CFS-S ACR: ($t_{A2} \geq 25 \text{ mm}$) on the upper side of the floor only
- Back filled with mineral wool, refer to Annex 2, chapter 2.2.
- **or**
- Gap filler: cementious Mortar M10 acc.EN 998-2
- Annular gap: 0 – 40 mm
- Depth to fill with cementious Mortar M10: to fill over entire floor thickness

3.4.2.41.2 All pipes named in 3.4.2.1;3.4.2.2; 3.4.2.3; 3.4.2.5; 3.4.2.6; 3.4.2.7; 3.4.2.8; 3.4.2.10; 3.4.2.11 in rigid floor ($t_E \geq 150$ mm), pipe group 1, EI 90 - U/U, Zero distance collar CFS-C EL to Hilti CFS-B, used to seal an elastomeric thermal insulation on metal pipes

Situation for EI 90 - U/U (refer to 3.1.11):

- Zero distance between CFS-C EL collar and CFS-B, wrapped around an elastomeric foamed thermal insulation on metallic pipe ($s_1 \geq 0$ mm)
- Type of pipes: refer to 3.4.2.1; 3.4.2.2; 3.4.2.3; 3.4.2.5; 3.4.2.6; 3.4.2.7; 3.4.2.8; 3.4.2.10; 3.4.2.11;
- Range of pipes: refer to 3.4.2.1; 3.4.2.2; 3.4.2.3; 3.4.2.5; 3.4.2.6; 3.4.2.7; 3.4.2.8; 3.4.2.10; 3.4.2.11;

Excluded are pipes with outside nominal diameter ($d_C > 110$ mm) .

Flexible, elastomeric thermal insulation D_E :

- Type of material: refer to 3.1.13
- Thickness of D_E : ($9,5 \text{ mm} \leq t_D \leq 40,5 \text{ mm}$)
- Insulation length: ($L_D \geq 250 \text{ mm}$) on pipes on both sides of the floor.
- CS situation

Metal pipes:

- Pipe diameter ($15 \text{ mm} \leq d_M \leq 76 \text{ mm}$)
- Pipe wall thickness of ($1,0 \text{ mm} \leq t_M \leq 14,2 \text{ mm}$)
- Covered material types for metal pipes – refer to 3.1.12., excluded material is copper

Gap size and gap filling:

- Gap filler: Hilti CFS-S ACR
 - Annular gap: 0 – 15 mm
 - Depth t_{A2} to be filled with Hilti CFS-S ACR: ($t_{A2} \geq 25$ mm)
 - No backfilling required
- or**
- Gap filler: Hilti CFS-S ACR
 - Annular gap: 0 – 40 mm
 - Depth t_{A2} to be filled with Hilti CFS-S ACR: ($t_{A2} \geq 25$ mm) on the upper side of the floor only
 - Back filled with mineral wool, refer to Annex 2, chapter 2.2.
- or**
- Gap filler: cementitious Mortar M10 acc. EN 998-2
 - Annular gap: 0 – 40 mm
 - Depth to be filled with cementitious Mortar M10: to fill over entire floor thickness

3.4.2.41.3 All pipes named in

3.4.2.1; 3.4.2.2; 3.4.2.3; 3.4.2.5; 3.4.2.6; 3.4.2.7; 3.4.2.8; 3.4.2.10; 3.4.2.11;

in rigid floor ($t_E \geq 150$ mm), pipe group 1, EI 90 - U/U,

Zero distance collar CFS-C EL to Hilti CFS-B, used to seal an elastomeric thermal insulation on aluminium composite und PP-R pipes

Situation for EI 90 - U/U (refer to 3.1.11):

- Zero distance between CFS-C EL collar and CFS-B, wrapped around an elastomeric foamed thermal insulation on aluminium composite und PP-R pipes ($s_1 \geq 0$ mm)
- Type of pipes: refer to 3.4.2.1; 3.4.2.2; 3.4.2.3; 3.4.2.5; 3.4.2.6; 3.4.2.7; 3.4.2.8; 3.4.2.10; 3.4.2.11;
- Range of pipes: refer to 3.4.2.1; 3.4.2.2; 3.4.2.3; 3.4.2.5; 3.4.2.6; 3.4.2.7; 3.4.2.8; 3.4.2.10; 3.4.2.11;

Excluded are only pipes with outside nominal diameter ($d_C > 110$ mm).

Pipes to CFS-C EL:

- See table below

Gap size and gap filling:

- Gap filler: Hilti CFS-S ACR
 - Annular gap: 0 – 15 mm
 - Depth t_{A2} to be filled with Hilti CFS-S ACR: ($t_{A2} \geq 25$ mm)
 - No backfilling required
- or**
- Gap filler: Hilti CFS-S ACR
 - Annular gap: 0 – 40 mm
 - Depth t_{A2} to be filled with Hilti CFS-S ACR: ($t_{A2} \geq 25$ mm) on the upper side of the floor only
 - Back filled with mineral wool, refer to Annex 2, chapter 2.2.
- or**
- Gap filler: cementitious Mortar M10 acc. EN 998-2
 - Annular gap: 0 – 40 mm
 - Depth to be filled with cementitious Mortar M10: to fill over entire floor thickness

Aluminum composite pipes and PP-R pipes EI120 U/C

Pipe Ø (mm)	Wall thickness (mm)	Pipe Insulation		
		Type	Thickness (mm)	Configuration (---)
Aquatherm green – material: PP-R – standard: EN 15874, DIN 8077/78				
20 - 110	1,9 - 10,0	elastomeric	8,0 - 40,5	CS
Fränkische Rohrwerke - Alpex F50 Profi – material: PE-X/Al/PE-X				
16 - 40	2,0 - 3,5	elastomeric	8,0 - 36,5	CS
63 - 75	4,5 - 5	elastomeric	39,0 - 40,5	CS
Geberit Mepla – material: PE-Xb/Al/PE-Xb				
16 - 63	2,25 - 4,5	elastomeric	9,0 - 39	CS
Georg Fischer - Sanipex – material: PE-Xc/Al/PE-Xb				
16 - 63	2,25 - 4,5	elastomeric	9,0 - 39	CS
Kekelit Kelox – material: PE-RT/Al/PE-RT				
16 - 75	2,0 - 7,0	elastomeric	8,0 - 40,5	CS
Kekelit Ketrix – material: Cryolen Polyolefinblend (POB) – standard: EN 15847				
20 - 75	1,9 - 6,8	elastomeric	8,0 - 40,5	CS
Polo-Polymutan – material: PP-R 80 – standard: DIN 8077/78				
20 - 75	1,9/6,8 - 12,5	elastomeric	8,0 - 40,5	CS
Polo-Polymutan ML5– material: PP-R				
20 - 75	2,8 - 10,8	elastomeric	8,0 - 40,5	CS
Prineto Stabil Rohr – material: PE-Xb/Al/PE-HD				
17 - 63	2,8 - 6,0	elastomeric	8,0 - 39,0	CS
Rehau Rautitan Flex – material: PE-Xa – standard: EN 151875				
16 - 63	2,2 - 8,6	elastomeric	8,0 - 39	CS
TECEflex Verbundrohr – material: PE-Xc/Al/PE				
16 - 63	2,2 - 6,0	elastomeric	9,0 - 39	CS
Uponor Unipipe MLC – material: PE-RT/Al/PE-RT				
16 - 63	2,0 - 6,0	elastomeric	8,0 - 35	CS
Uponor Unipipe Plus – material: PE-RT/Al/PE-RT				
16 - 32	2,0 – 3,0	elastomeric	8,0 – 35,0	CS

Viega - SANIFIX Fosta-Rohr – material: PE-Xc/Al/PE-Xc				
16 - 63	2,2 – 4,5	elastomeric	8,0 – 39,0	CS
Viega Raxofix – material: PE-Xc/Al/PE-Xc				
16 - 63	2,2 – 3,2	elastomeric	8,0 - 39,0	CS
Wavin TS – material: PE 100				
50 - 75	4,6 – 6,8	elastomeric	9,0 – 40,5	CS

3.4.2.41.4 All pipes named in

3.4.2.1; 3.4.2.2; 3.4.2.3; 3.4.2.5; 3.4.2.6; 3.4.2.7; 3.4.2.8; 3.4.2.10; 3.4.2.11;

in rigid floor ($t_E \geq 150$ mm), pipe group 1, EI 90 - U/U,

Zero distance collar to Hilti CFS-B, wrapped around PE foamed insulation or PE protection tube on aluminium composite pipes

Situation for EI 90 - U/U:

- Zero distance between CFS-C EL collar and CFS-B, wrapped around PE foamed insulation or PE protection tube on aluminium composite pipes ($s_1 \geq 0$ mm)
- Type of pipes: refer to 3.4.2.1; 3.4.2.2; 3.4.2.3; 3.4.2.5; 3.4.2.6; 3.4.2.7; 3.4.2.8; 3.4.2.10; 3.4.2.11;
- Range of pipes: refer to 3.4.2.1; 3.4.2.2; 3.4.2.3; 3.4.2.5; 3.4.2.6; 3.4.2.7; 3.4.2.8; 3.4.2.10; 3.4.2.11;

Excluded are pipes with outside nominal diameter ($d_C > 110$ mm) .

Pipes to CFS-C EL:

- See table below)

Gap size and gap filling:

- Gap filler: Hilti CFS-S ACR
- Annular gap: 0 – 15 mm
- Depth t_{A2} to be filled with Hilti CFS-S ACR: ($t_{A2} \geq 25$ mm)
- No backfilling required
- **or**
- Gap filler: Hilti CFS-S ACR
- Annular gap: 0 – 40 mm
- Depth t_{A2} to be filled with Hilti CFS-S ACR: ($t_{A2} \geq 25$ mm) on the upper side of the floor only
- Back filled with mineral wool, refer to Annex 2, chapter 2.2.
- **or**
- Gap filler: cementious Mortar M10 acc. EN 998-2
- Annular gap: 0 – 40 mm
- Depth to be filled with cementious Mortar M10: to fill over entire floor thickness

Pipe Ø (mm)	Wall thickness (mm)	Pipe Insulation		
		Type	Thickness (mm)	Configuration (mm)
Geberit Mepla – material: PE-Xb/Al/PE-Xb				
16 - 26	2,2 - 3,0	PE-foam	6,0 – 13,0	CS
Kekelit Kelox – material: PE-RT/Al/PE-RT				
14 - 32	2,0 - 3,0	PE-foam	4,0 – 9,0	CS
16 - 20	2,0 - 2,25	PE-HD tube		LS ≥ 250
16 - 20	2,0 - 2,25	PE Foam+ PE-HD tube	4,0	CS
Uponor Unipipe MLC – material: PE-RT/Al/PE-RT				
16 - 20	2,0 - 2,25	PE-HD tube		LS ≥ 250
Uponor Unipipe Plus – material: PE-RT/Al/PE-RT				
16 - 25	2,0 - 2,5	PE foam	4,0 -10,0	CS

3.4.2.42 All pipes named in

3.4.2.1; 3.4.2.2; 3.4.2.3; 3.4.2.5; 3.4.2.6; 3.4.2.7; 3.4.2.8; 3.4.2.10; 3.4.2.11

in rigid floor ($t_E \geq 150$ mm), pipe group 1, EI 90 - U/U,

Pipes installed in mineral wool board CFS-CT B and sealed with CFS-C EL Collar

Situation for EI 90 - U/U (refer to 3.1.14):

- Plastic pipes, penetrating a wall seal made off mineral wool board, could be sealed with CFS-C EL
- Type of pipes: refer to 3.4.2.1; 3.4.2.2; 3.4.2.3; 3.4.2.5; 3.4.2.6; 3.4.2.7; 3.4.2.8; 3.4.2.10; 3.4.2.11
- Range of pipes: refer to 3.4.2.1; 3.4.2.2; 3.4.2.3; 3.4.2.5; 3.4.2.6; 3.4.2.7; 3.4.2.8; 3.4.2.10; 3.4.2.11
- Excluded are only pipes with outside nominal diameter ($d_C > 110$ mm) .
- Distance between the pipes penetrating the board is ($s_1 \geq 100$ mm)
- Pipes have to be grouped in line only
- The number of penetrating pipes in line is not limited.
- Pipe are approved with zero distance to building element ($s_3 \geq 0$ mm)
- Gap seal around the board to building element is CFS-S ACR
- Gap seal around the pipes to board or building element is CFS-S ACR
- For approved boards refer to 3.1.14 and Annex 2, Chapter 2.2.

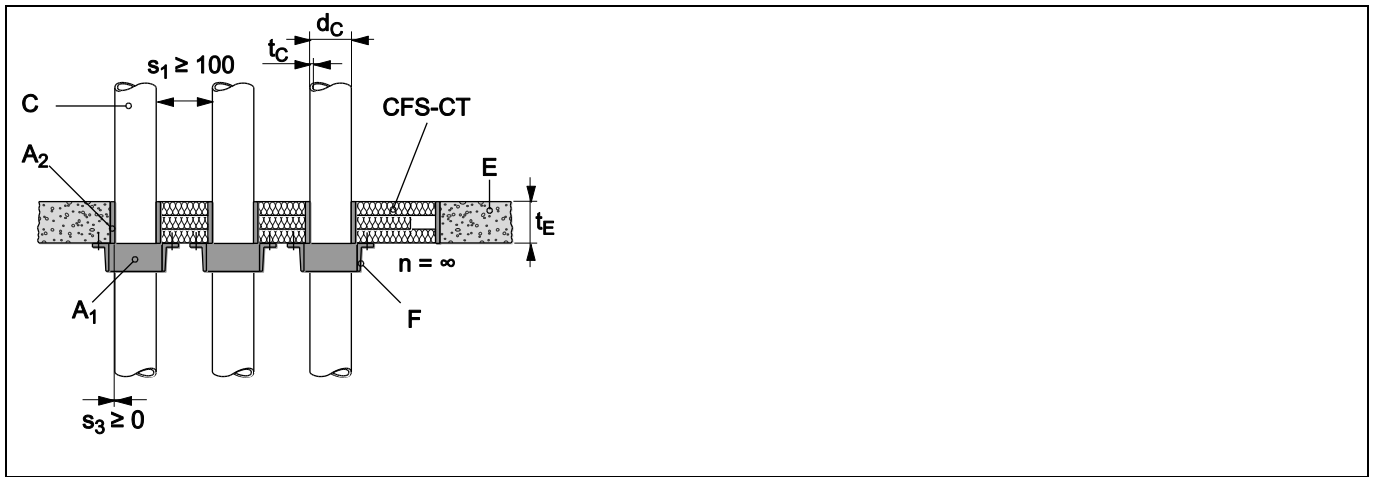

3.4.2.43 Roof drainage, covered with foamed elastomeric thermal insulation in rigid floor ($t_E \geq 150$ mm), pipe group 1 and 2, EI 120 -180 U/U

- **Situation for roof drainage for EI 120 -180 U/U:** One pipe (U/U) insulated with elastomeric foamed insulation, sealed with CFS-C EL

Pipe:

- Material : see table below
- Pipe outside diameter see table below
- Pipe wall thickness see table below

Elastomeric foamed thermal insulation:

- For material type refer to 3.1.13
- Insulation thickness : see table below
- Installation situation is LS and CS
- Minimum insulation length ($L_D \geq 250$ mm) on both sides of the floor

Gap size and Gap filler:

- Gap size is 5 mm to 30 mm
- Gap filler is CFS-FIL
- Installation depth: ($t_{A3} \geq 25$ mm) on each side of the floor

Collar fixing in pipe group 1 and 2:

- For perpendicular situation (90°): refer to 3.1.4 and Tab.3 , for hook fixing refer to 3.1.3 and Tab.2

Rigid floor ($t_E \geq 150$ mm)			
Pipe material	PE	PE	PP
Norm/standard/ Producer/product	EN 1519-1, EN12666-1, EN 12201-2	Non-regulated, Geberit Silent dB20	Non-regulated, See 3.1.15
Pipe diameter d_c	Pipe group 1: ($40 \leq d_c \leq 110$ mm)	Pipe group 1: ($40 \leq d_c \leq 110$ mm)	Pipe group 1: See graphic

	Pipe group 2: see graphic 3.3.2.43 A below	Pipe group 2: see graphic 3.3.2.43 B below	3.3.2.43 C Pipe group 2: 3.3.2.43 D below
Pipe wall thickness t_C	Pipe group 1: ($t_C = 4,2$ mm) Pipe group 2: see graphic 3.3.2.43 A below	Pipe group 1: ($t_C = 6,0$ mm) Pipe group 2: see graphic 3.3.2.43 B below	Pipe group 1: See graphic 3.3.2.43 C Pipe group 2: 3.3.2.43 D below
Insulation thickness t_D	($t_D = 19$ mm)	($t_D = 19$ mm)	($t_D = 19$ mm)
Classification	pipe group 1: EI120 pipe group 2: EI180	pipe group 1: EI180 pipe group 2 : EI240	group 1 and 2: EI120

Pipe Range 3.4.2.43A:

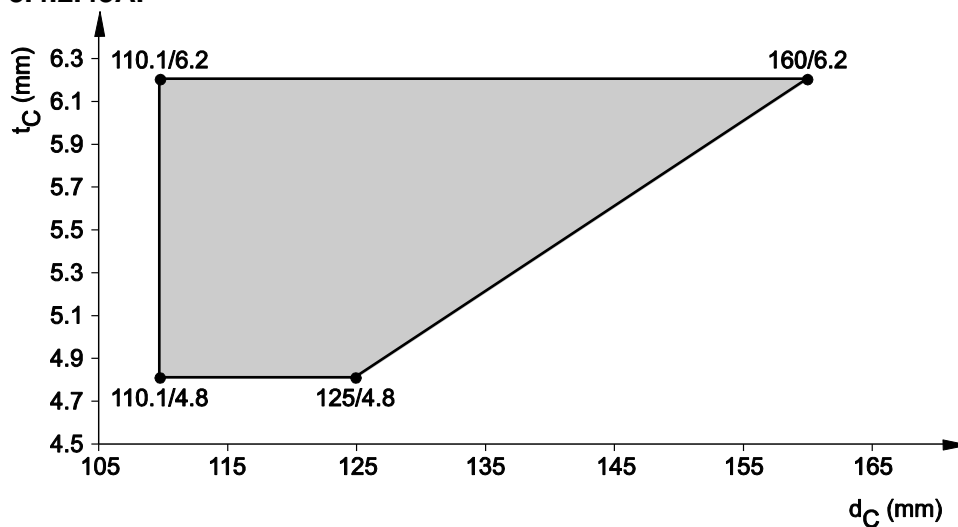

Pipe Range 3.4.2.43B:

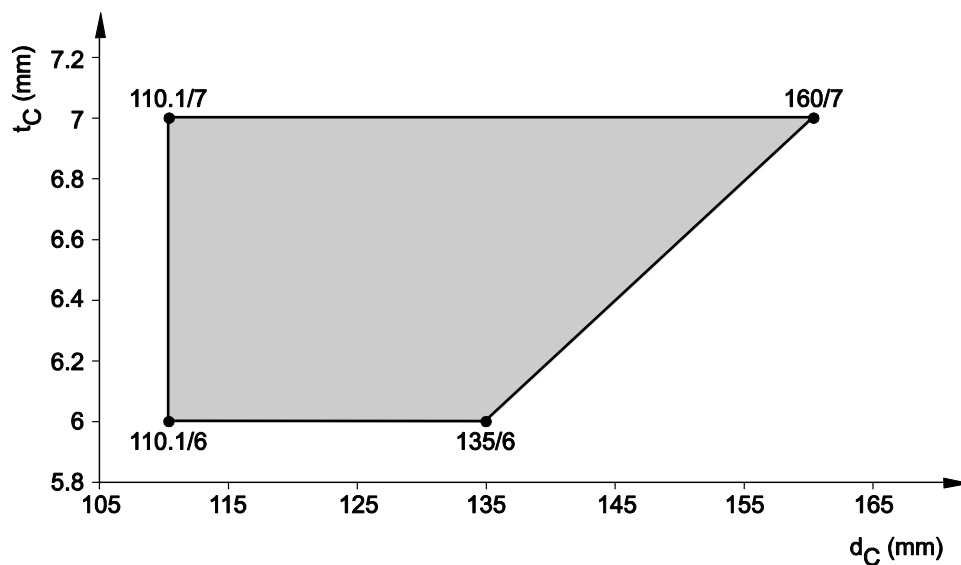

Pipe Range 3.4.2.43C:

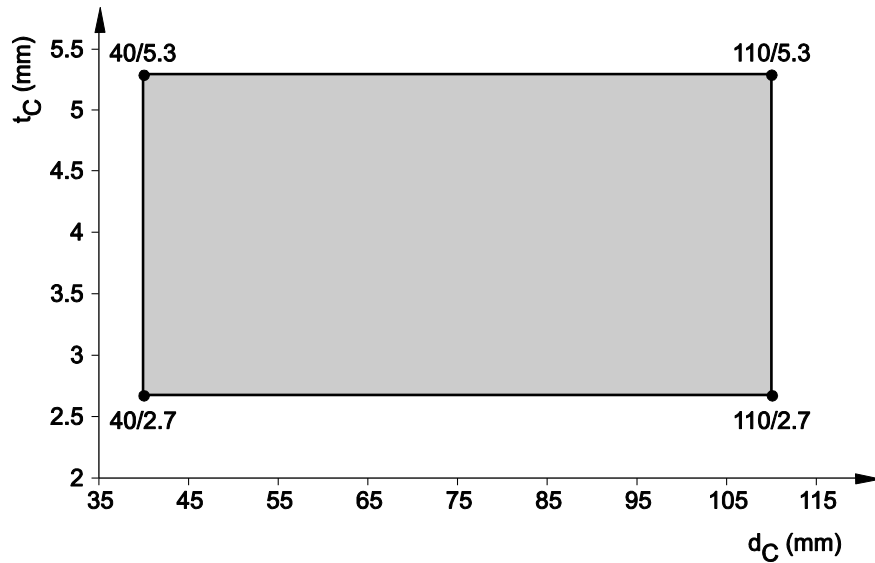

Pipe Range 3.4.2.43D:

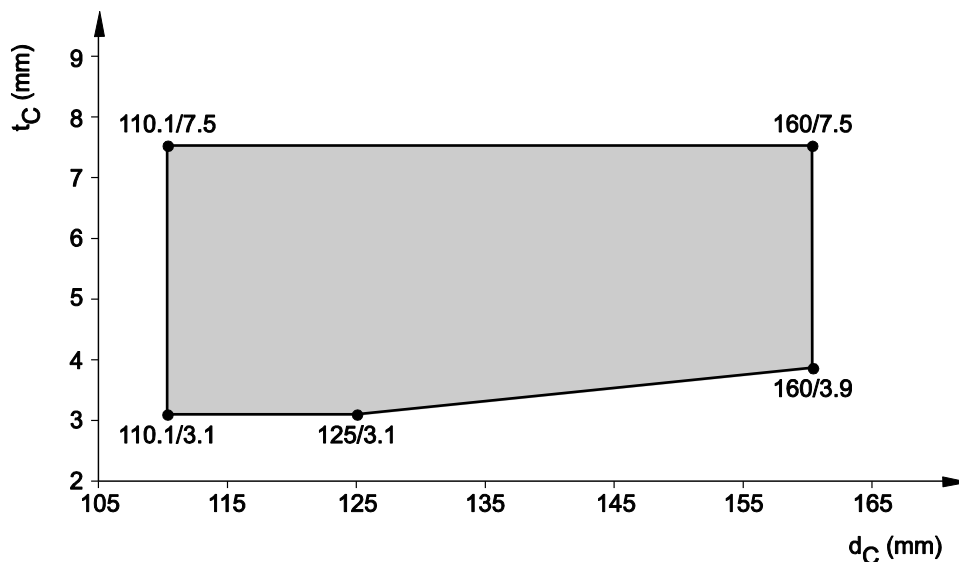

3.4.2.44 Pipe junction/manifold inside the floor, in rigid floor ($t_E \geq 150$ mm), pipe group 1 and 2, EI 120 - U/U, EI 90 - U/U and EI 60 - U/U

Situation:

- An U/U classified waste water pipe (C) penetrates a floor in perpendicular situation, sealed with CFS-C EL on soffit only (refer to 3.4.2)
- Inside the floor there are one or more pipe junctions/manifolds into the central waste water pipe, where horizontal running minor pipes flow into the central waste water pipe
- Those minor pipes are always in U/C constellation
- For pipe material / pipe dimension of (C) see Tab.4 below, for classification see Tab.4 below
- Pipe diameter ($32 \leq d_C \leq 160$ mm)
- Gap sealing: refer to 3.4.1.2
- Arrangement of smaller pipes in U/C constellation: in line
- Number of smaller pipes in U/C constellation: unlimited

- Distance pipe to pipe between smaller pipes in U/C constellation: $s_1 \geq 15\text{mm}$
- Distance between U/U classified main waste water pipe (C) and smaller pipes in U/C constellation: $s_1 \geq 15\text{mm}$

Chapter within this ETA, describing approved pipe dimensions and material for (C)	For EI 120 – U/U:	For EI 90 – U/U:	For EI 60 – U/U:
3.4.2.1	x	x	x
3.4.2.2	x	x	x
3.4.2.3	x	x	x
3.4.2.4	x	x	x
3.4.2.5		x	x
3.4.2.6	x	x	x
3.4.2.7	x	x	x
3.4.2.8		x	x
3.4.2.10	x	x	x
3.4.2.11	x	x	x
3.4.2.14	x	x	x
3.4.2.15	x	x	x
3.4.2.16			x
3.4.2.17		x	x
3.4.2.19	x	x	x
3.4.2.20		x	x
3.4.2.21	x	x	x
3.4.2.22	x	x	x
3.4.2.24	x	x	x
3.4.2.26	x	x	x

Tab.4: Approved classification for vertical positioned waste water pipes (C) with plastic pipe junctions/manifolds located within the floor itself, connecting the main pipe (C) with smaller, nearly horizontal running plastic pipes as shown below:d

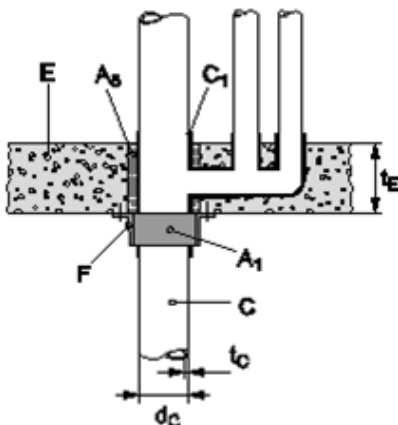

**3.4.2.45 PP pipes acc. EN 1451-1 and DIN 8077/78
in rigid floor ($t_E > 150$ mm), pipe group 1, EI 120 - U/U, Pipe coupling**

Situation for EI 120 - U/U:

- Pipe coupling inside the wall, half in the wall or outside the wall, covered by CFS-C EL
- Type of pipes: PP pipes acc. EN 1451-1
- Pipe insulation: see 3.1.6

Pipe range:

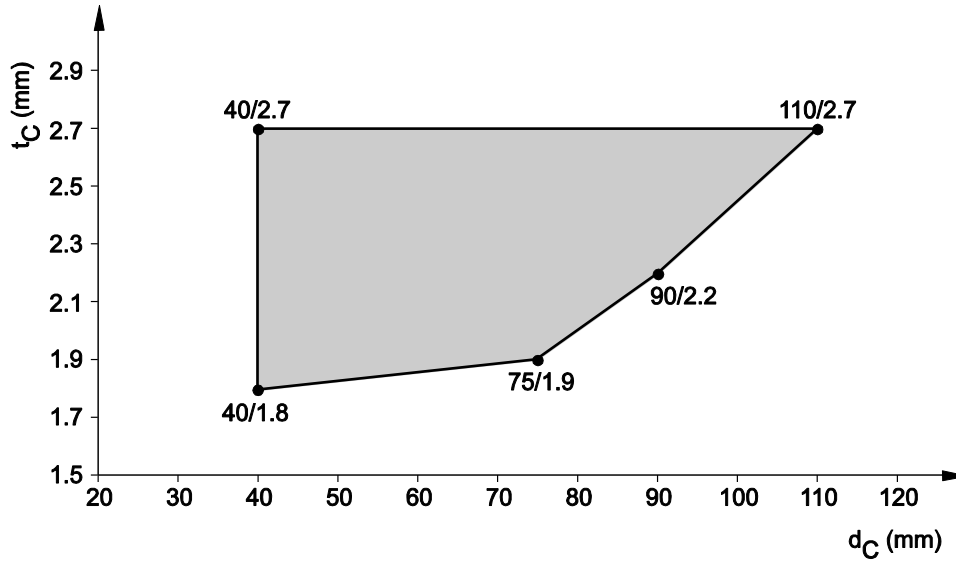

Gap size and gap filler:

In rigid wall application ($t_E > 150$ mm):

- Gap filler: Hilti CFS-FIL
- Annular gap: 5 – 30 mm
- Depth t_{A2} to be filled with Hilti CFS-FIL: ($t_{A2} > 25$ mm)
- No backfilling required

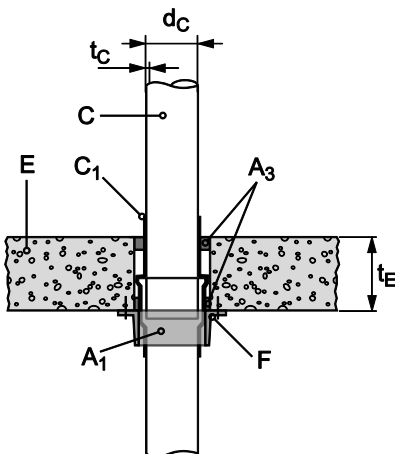

Requested number of hooks:

Pipe outside nominal diameter d_C (mm)	Acoustic Pipe Insulation Thickness t_D (mm) (incoming pipe / outgoing pipe)		
	0	4	9
40	2 / 2	2 / 2	2 / 2
41 -75	3 / 3	3 / 3	3 / 3
76 - 90	3 / 3	3 / 3	3 / 3
91-110	4/4	4 / 4	4 / 4

If pipe insulation thickness is between 0 and 4mm use the number of hooks indicated for 4 mm. If pipe insulation thickness is between 4 and 9 mm use the number of hooks indicated for 9 mm.

3.4.2.46 PP pipes acc. EN 1451-1 and DIN 8077/78, in rigid floor ($t_E > 150$ mm), pipe group 1, EI 120 - U/U, Pipe Elbow 87°

Situation for EI 120-U/U:

- Elbow connector (87°), Elbow partly inside the floor, covered by CFS-C EL
- On one side the pipe may run parallel to the floor having a zero distance to floor ($s_3 > 0$ mm).

Pipe range:

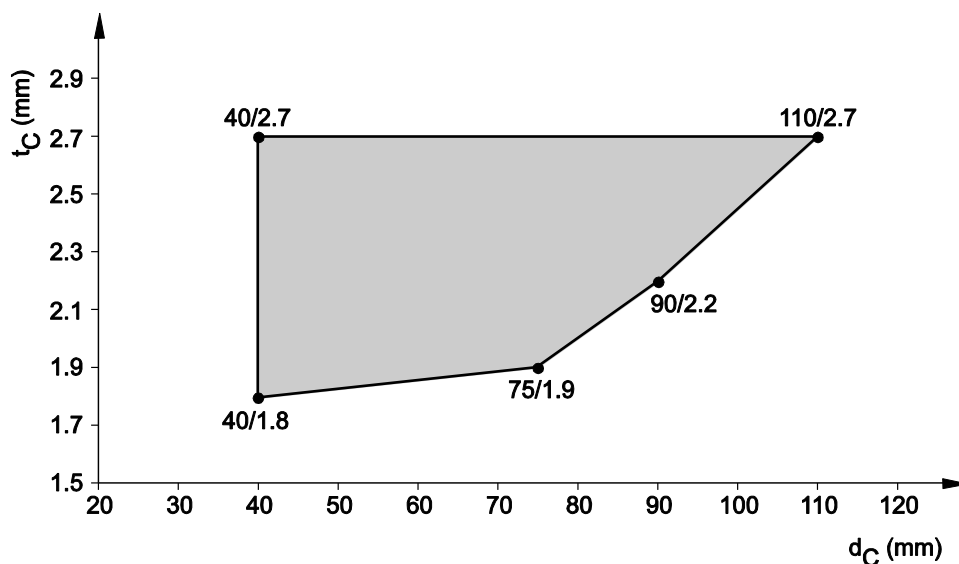

Gap size and Gap filling:

- Gap filler: Hilti CFS-S ACR
- Annular gap: 0 – 15 mm
- Depth t_{A2} to be filled with Hilti CFS-S ACR: ($t_{A2} > 25$ mm)
- No backfilling required
- **or**
- Gap filler: Hilti CFS-S ACR

- Annular gap: 0 – 40 mm
- Depth t_{A2} to be filled with Hilti CFS-S ACR: ($t_{A2} > 25$ mm) on the upper side of the floor only
- Backfilling required, refer to Annex 2, chapter 2.2

or

- Gap filler: cementious Mortar M10 acc. EN 998-2
- Annular gap: 0 – 40 mm
- Depth to be filled with cementious Mortar M10: to fill over entire floor thickness

Collar fixing:

- Refer to 3.1.3

Number of hooks:

Pipe outside nominal diameter d_C (mm)	Acoustic Pipe Insulation Thickness t_D (mm)		
	(no elbow side - vertical running pipe / elbow side - horizontal running pipe)		
	0	4	9
40 - 74	3 / 3	3 / 3	3 / 3
75 - 109	3 / 3	3 / 3	3 / 3
110	4 / 4	4 / 4	4 / 4

If pipe insulation thickness is between 0 and 4 mm use the number of hooks indicated for 4 mm.
If pipe insulation thickness is between 4 and 9 mm use the number of hooks indicated for 9 mm.

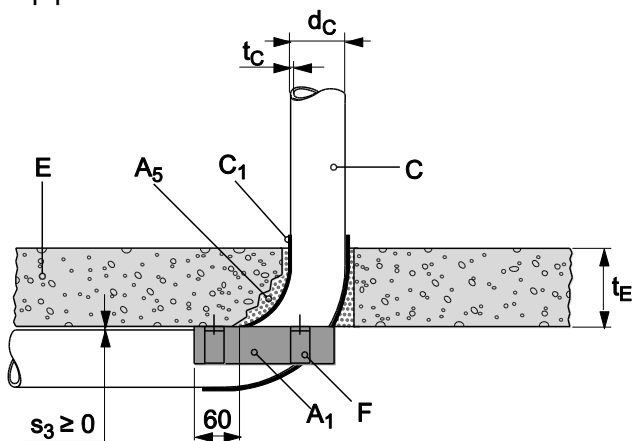

**3.4.2.47 PVC pipes acc. EN 1452-1, EN 1329-1, EN 1453-1, EN 1566-1; DIN 8061/62,
EN ISO 15493 in rigid floor ($t_E > 150$ mm), pipe group 1, EI 120 - U/U,
Pipe Elbow 87°**

Situation for EI 120-U/U:

- Elbow connector (87°), Elbow partly inside the floor, covered by CFS-C EL
- On one side the pipe may run parallel to the floor having a zero distance to floor ($s_3 > 0$ mm).

Pipe range:

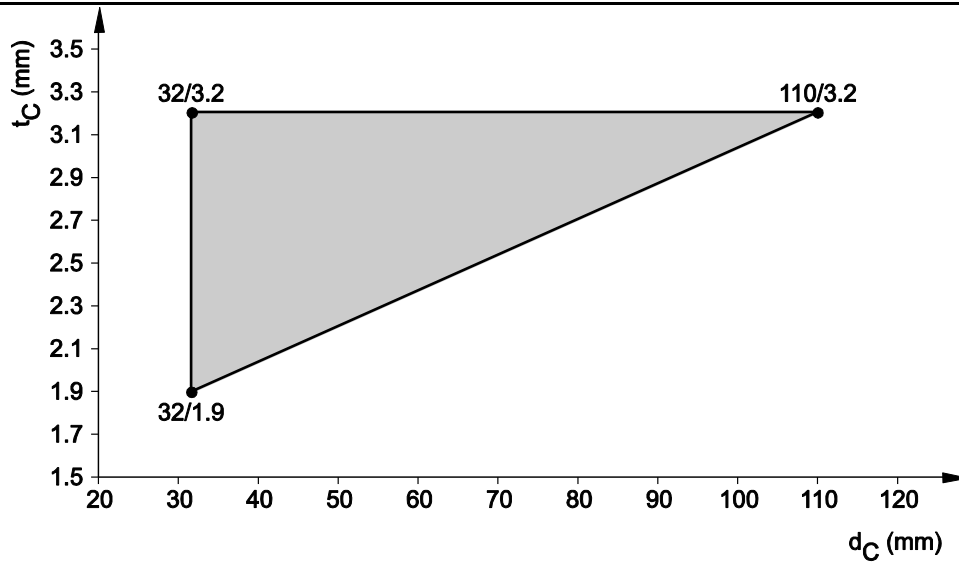

Gap size and Gap filling:

- Gap filler: Hilti CFS-S ACR
- Annular gap: 0 – 15 mm
- Depth t_{A2} to be filled with Hilti CFS-S ACR: ($t_{A2} > 25$ mm)
- No backfilling required
- **or**
- Gap filler: Hilti CFS-S ACR
- Annular gap: 0 – 40 mm
- Depth t_{A2} to be filled with Hilti CFS-S ACR: ($t_{A2} > 25$ mm) on the upper side of the floor only
- Backfilling required, refer to Annex 2, chapter 2.2
- **or**
- Gap filler: cementious Mortar M10 acc. EN 998-2
- Annular gap: 0 – 40 mm
- Depth to be filled with cementious Mortar M10: to fill over entire floor thickness

Collar fixing:

- Refer to 3.1.3

Number of hooks:

Pipe outside nominal diameter d_C (mm)	Acoustic Pipe Insulation Thickness t_D (mm)		
	(no elbow side - vertical running pipe / elbow side - horizontal running pipe)		
	0	4	9
32 - 109	3 / 3	3 / 3	3 / 3
110	4 / 4	4 / 4	4 / 4

If pipe insulation thickness is between 0 and 4 mm use the number of hooks indicated for 4 mm.
If pipe insulation thickness is between 4 and 9 mm use the number of hooks indicated for 9 mm.

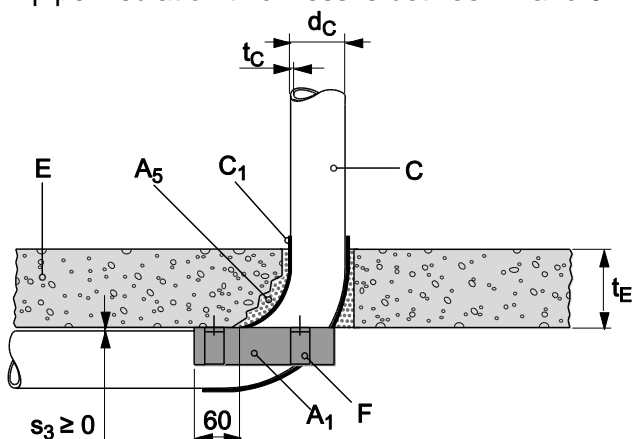

3.5 Shaft walls

3.5.1 Specific characteristics for Shaft walls

3.5.1.1 Suitable Shaft wall systems

Hilti Firestop Collar Endless CFS-C EL (A₁) can be used to seal plastic pipes installed in shaft wall systems classified at least with EI 90 according EN 13501-2. The mechanical resistance and stability has to be given for the required fire resistance period.

The Shaft Wall should consists of the following components:

- Plates:** Two layers each of 25 mm Knauf Fireboard plates (acc. EN 15283-1), combustibility class A1 acc. EN 13501-1
- Track and Studs:** CW and UW Profil 75,
Track should be minimum a 75 mm x 40 mm x 0,6 mm thick galvanized mild steel
Stud should be minimum a 73,5 mm x 43,5 mm x 0,55 mm thick galvanized mild steel
- Fixing/Screws:** First layer should be fixed using 35 mm long x 3,5 mm diameter flexible wall screws, second layer should be fixed with 55 mm long x 3,5 mm diameter flexible wall screws.
- GYPSUM:** KNAUF FIREBOARD SPACHTEL, gypsum based plaster or similar

3.5.1.2 Penetrating pipes:

- pipes in pipe group 1 , nominal pipe outside diameter ($d_c \leq 110$ mm)
- only single penetration seals
- Hilti Firestop Collar Endless CFS-C EL (A₁) on both sides of the shaft wall
- For pipe material and pipe dimension refer to 3.5.2

3.5.1.3 Annular Gap

- Annular gap around penetrating pipes should be 5 to 40 mm.

3.5.1.4 Collar installation

Collar installation in shaft walls can be done from one side only (limited access to the other side).

3.5.1.5 Gap Filler in Shaft Walls

- Hilti CFS-FIL to be used as the gap filler (refer to Annex 2, chapter 2.2)
- CFS-FIL has to be applied from one side over the entire thickness of the wall.
- Consider the Instruction for Use (Annex 5)

3.5.1.6 Collar fixing

- Refer to 3.1.3

3.5.1.7 Requested number of hooks / hook fixing

- For number of hooks: refer to 3.1.4 and Tab.3
- For hook fixing: refer to 3.1.3 and Tab.2
- Fixing of all hooks from one side of the wall possible
- Due to one side installation long and short hooks are requested
- Consider the identical number of long and short hooks
- One long and one short hook may be fixed to the wall using a single point of fixing
- Consider the Instruction for Use (Annex 5) .

3.5.1.8 Pipe supporting framework

Pipes shall be supported at maximum 250 mm away from both faces of wall constructions.

3.5.1.9 Sound decoupling insulation:

No sound decoupling insulation material should be used on pipes penetrating a shaft wall.

3.5.1.10 Recycling of oddments

No oddments should be used.

3.5.1.11 Pipe orientation

All pipes must penetrate the shaft wall in a perpendicular orientation only.

3.5.1.12 Minimum distance pipe to pipe in shaft walls

The minimum distance pipe to pipe penetrating a shaft wall and sealed by using Hilti Firestop Collar Endless CFS-C EL distance should be 200 mm. Direct contact pipe to pipe (in line or in cluster) are not approved.

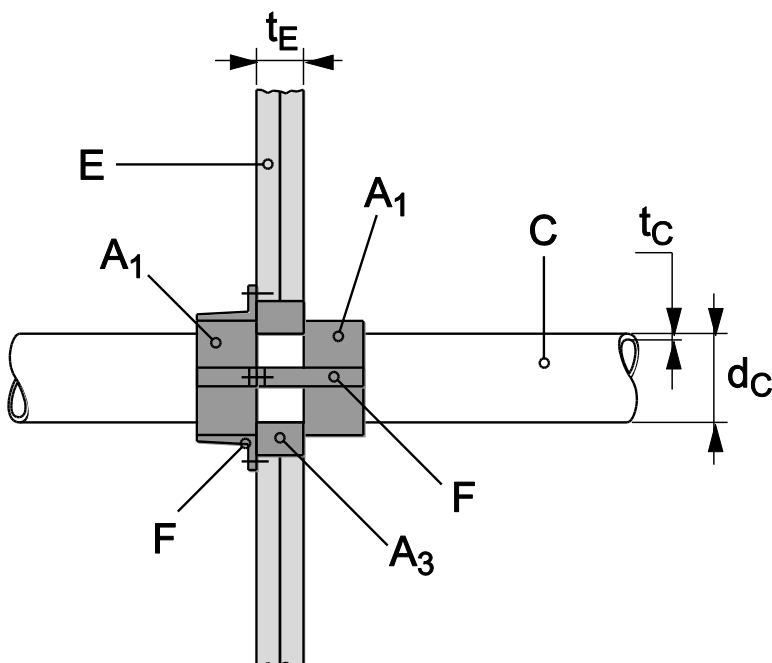

3.5.2 Penetration service in shaft walls

3.5.2.1 PE pipes acc. EN 1519-1, EN 12201-2 and EN 12666-1 , in shaft wall, pipe group 1, EI 90 - U/U

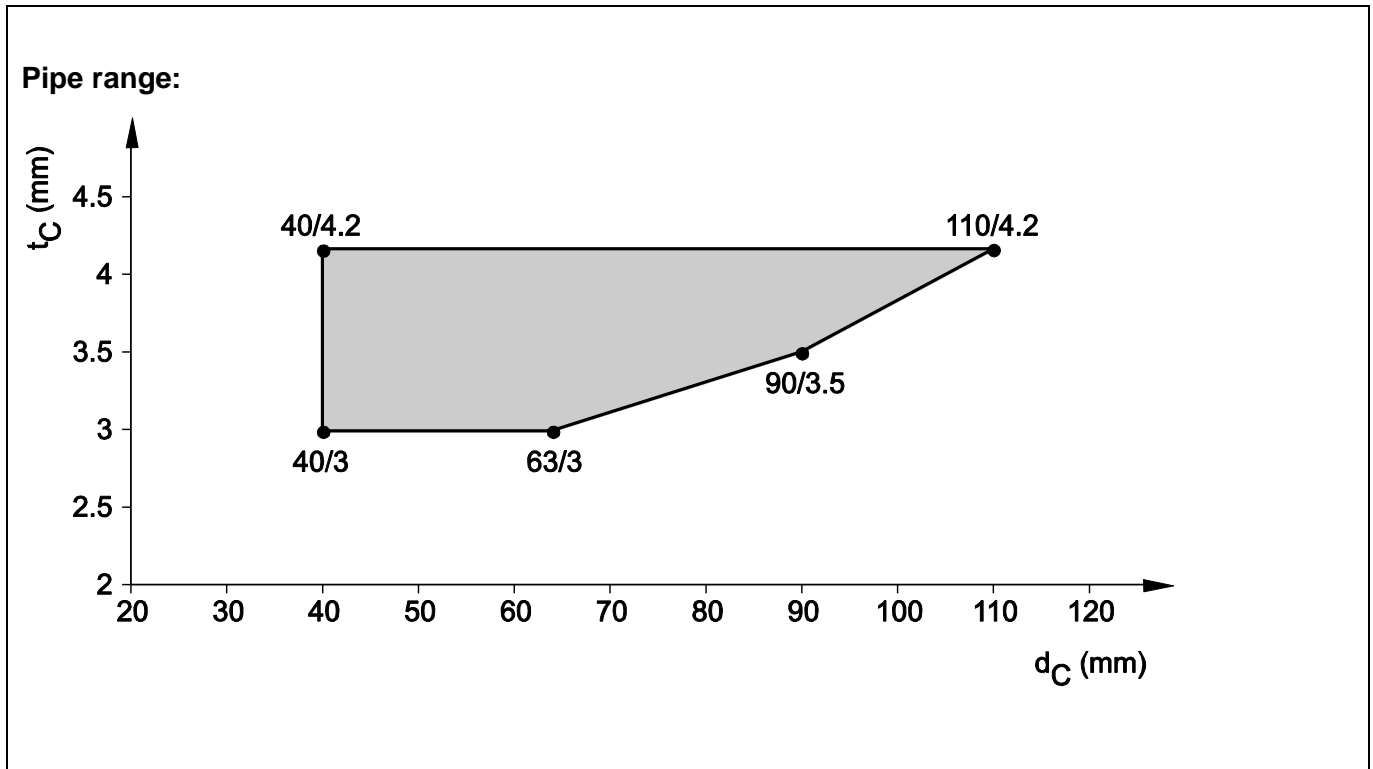

3.5.2.2 PE pipes acc. EN 15494, EN 12201-2 and DIN 8074/75 in shaft wall, pipe group 1, EI 90 - U/U

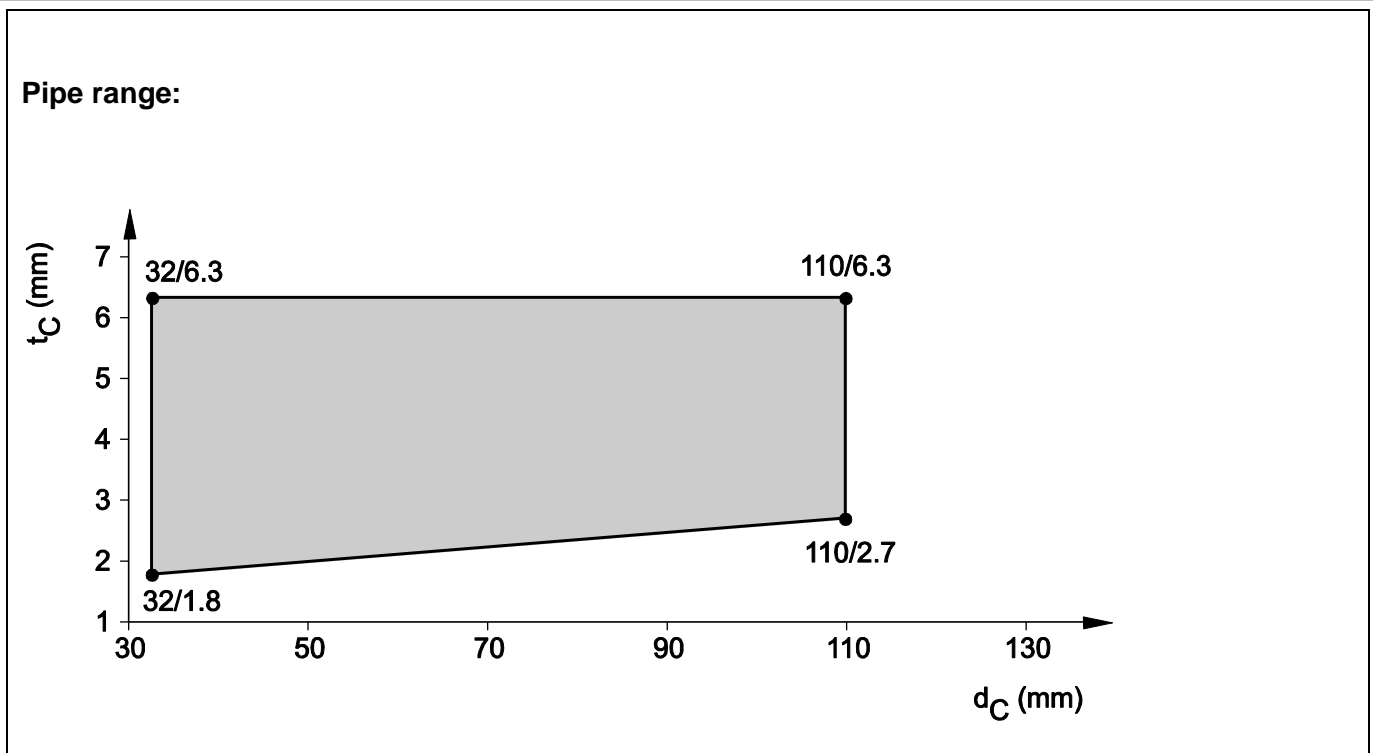

3.5.2.3 PVC pipes acc. EN 1452-1, EN 1329-1, EN1453-1, EN 1566-1, EN ISO 15493 and DIN 8061/62, in shaft wall, pipe group 1, EI 90 - U/U

Pipe range:

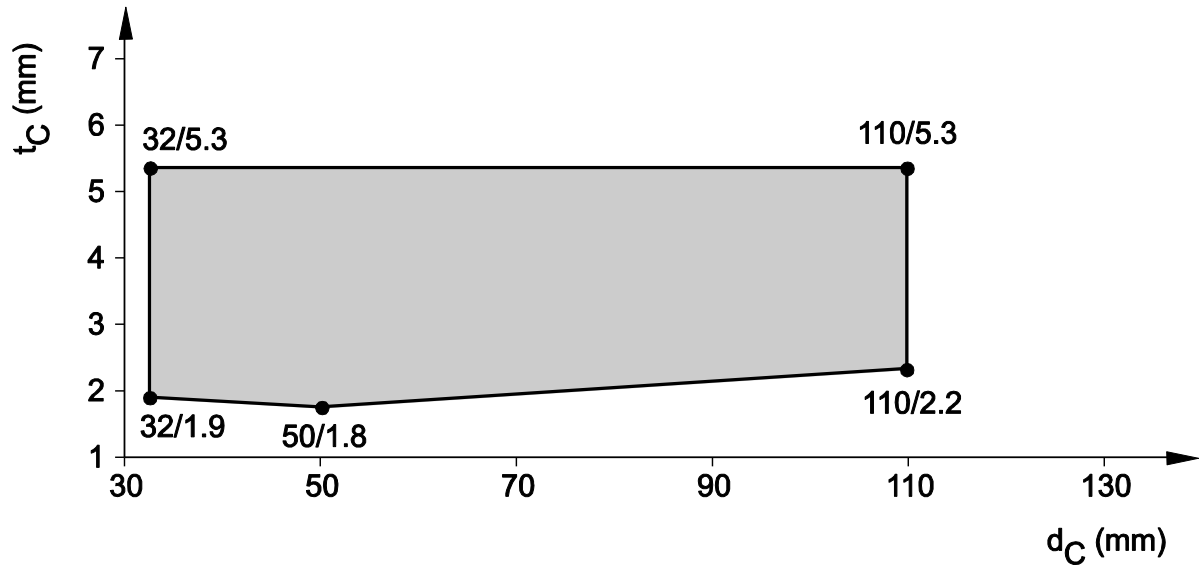

3.5.2.4 PP pipes, non-regulated,
in shaft wall, pipe group 1, EI 90 - U/U

Pipe range:

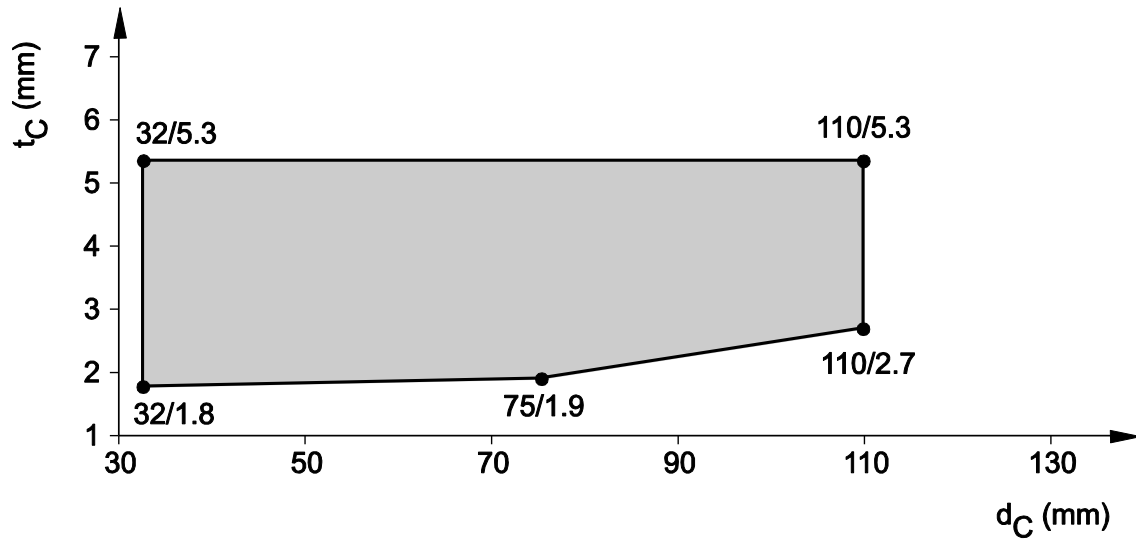

For pipe material and pipe type: refer to 3.1.15

3.5.2.5 PP pipes acc. EN 1451-1 and DIN 8077/78
in shaft wall, pipe group 1, EI 90 - U/U

Pipe range:

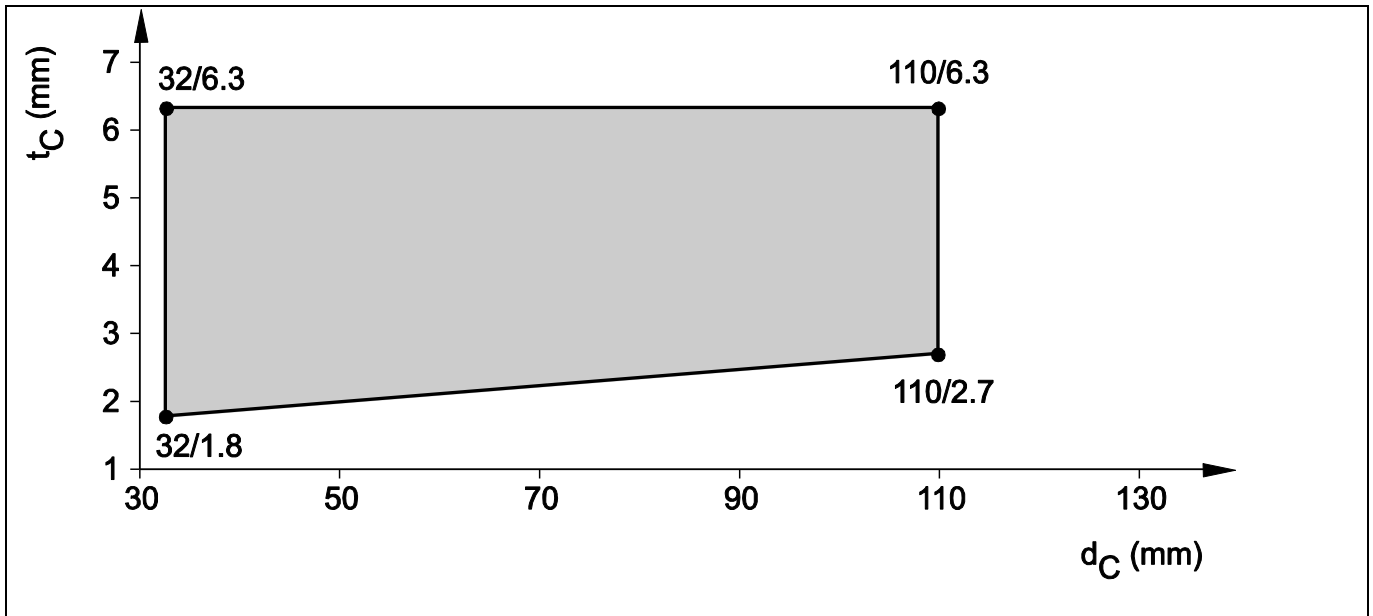

3.5.2.6 PE pipes non-regulated (Geberit Silent dB20) in shaft wall, pipe group 1, EI 90 - U/U

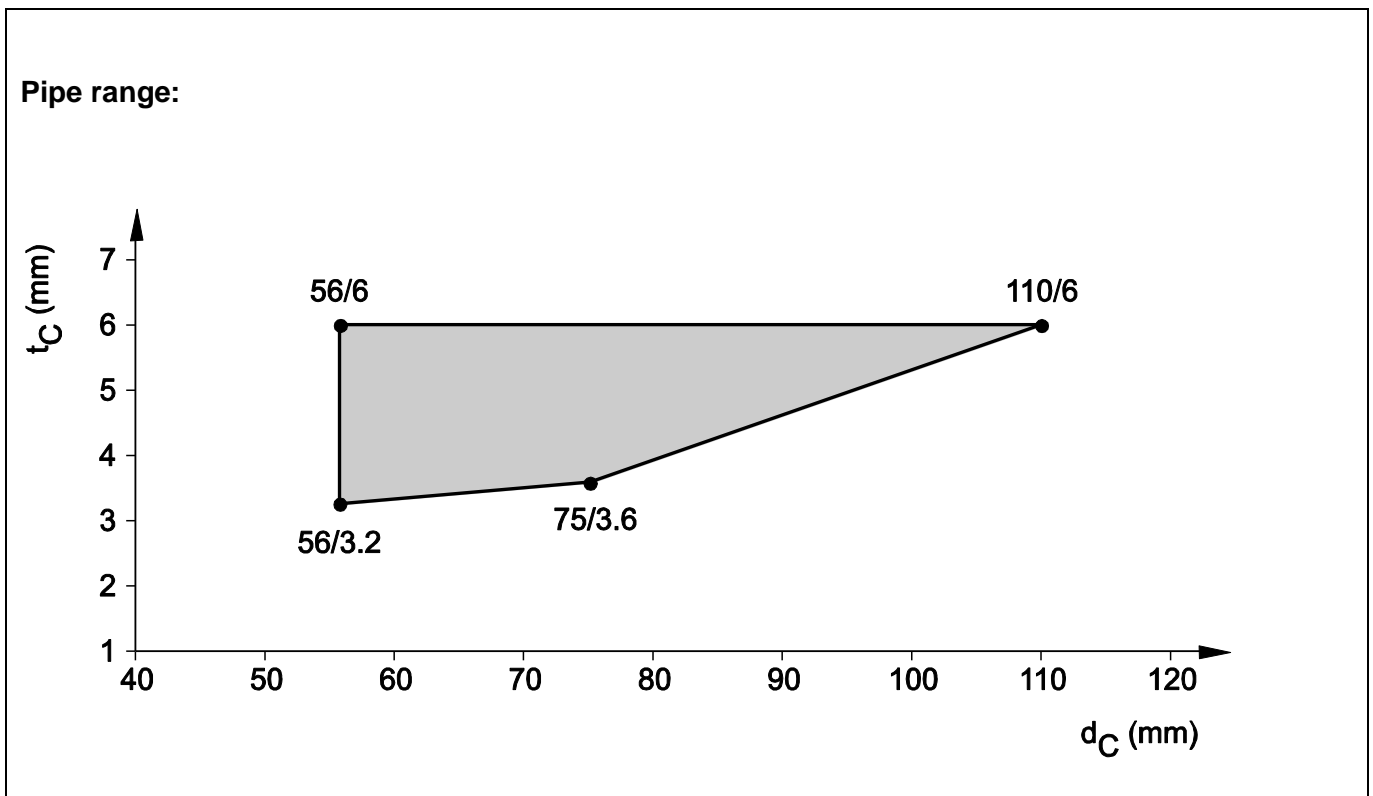

3.5.2.7 ABS pipes acc. EN 1455-1, EN 15493 and SAN+PVC-pipes acc. EN 1565-1, in shaft wall, pipe group 1, EI 90 - U/U

Pipe range:

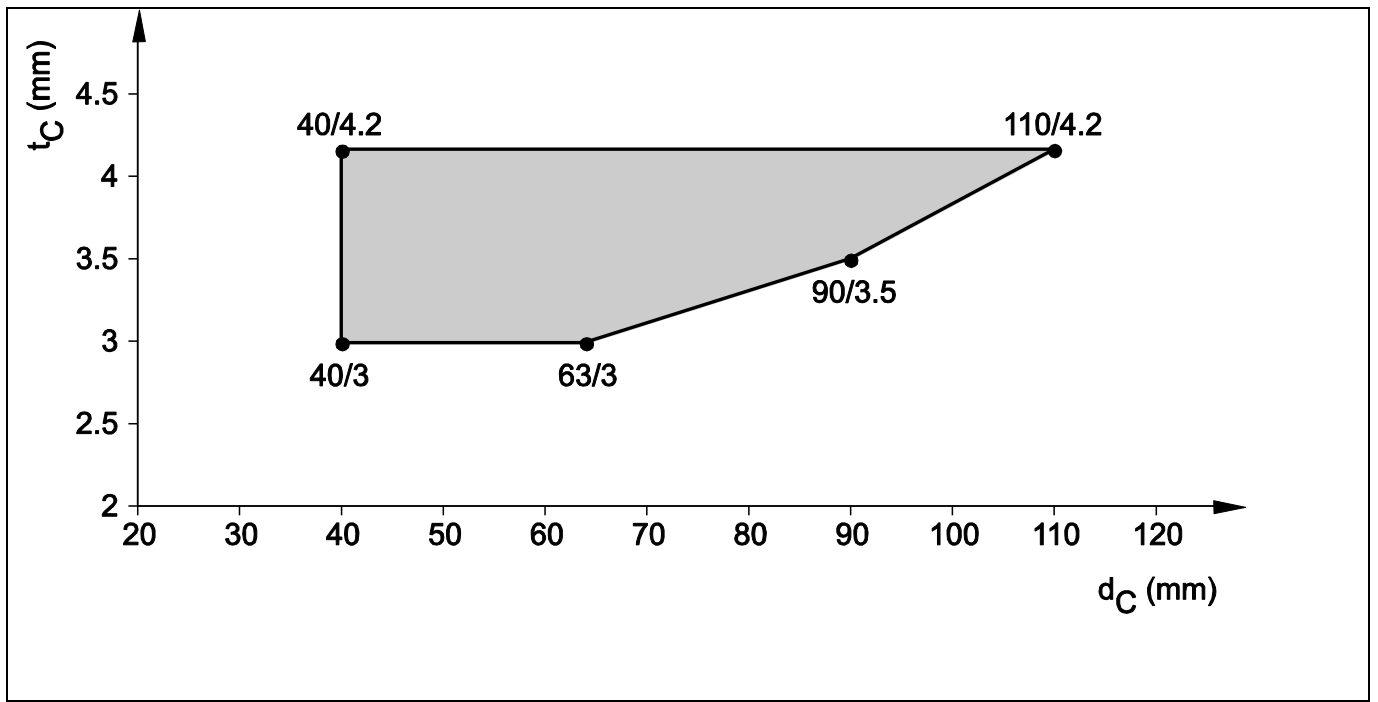

ANNEX 4

ABBREVIATIONS AND REFERENCE DOCUMENTS

4.1 Abbreviations used in drawings

Abbreviation	Description
A ₁	Hilti Firestop Collar Endless CFS-C EL
A ₁₀	Hilti Firestop Collar Endless CFS-C EL with oddment
A ₂	Annular gap seal with Hilti Firestop Acrylic Sealant CFS-S ACR
A ₃	Annular gap seal with Hilti CFS-FIL
A ₄	Annular gap seal with gypsum plaster
A ₅	Annular gap seal with cementious mortar acc. EN 998-2, group M10
B	Backfilling material (mineral wool)
C	Plastic Pipe
C ₁	Sound decoupling insulation
D	Pipe insulation
D _W	Pipe insulation, incombustible, based on mineral wool
D _E	Pipe insulation, combustibile, based on elastomeric foamed material
D _P	Pipe insulation, Protect insulation
d _C	Pipe diameter (nominal outside diameter) for plastic pipes
d _M	Pipe diameter (nominal outside diameter) for metal pipes
E	Building element (wall, floor)
F	Hooks (long or short) for Fixing of the collar
M	Metal pipe
s ₁	Minimum distance between single penetration seals
s ₂	Minimum distance between clustered pipe
s ₃	Minimum distance between penetrating pipe and building element
t _{A2}	Thickness of Hilti Firestop Acrylic Sealant CFS-S ACR
t _{A3}	Thickness of Hilti CFS-FIL
t _C	Plastic Pipe wall thickness
t _M	Metal Pipe wall thickness
t _D	Insulation thickness
t _E	Thickness of the building element
L _D	Length of Insulation
ρ _E	Density of the building element
n	amount, number of pieces