

**TECHNICAL INFORMATION**  
**HCV 3 - HCV 4 - HCV 5 - HCH 5 - HCH 8**  
**Demand-controlled home ventilation**

---



**Dantherm**<sup>®</sup>  
CONTROL YOUR CLIMATE



# HCV/HCH Home ventilation

1	General description	5
2	Control	9
3	Technical data	13
4	Accessories	27





HCV 3 model



HCV 3 in standard 60x60 kitchen unit



HCH model

## GENERAL DESCRIPTION

The HCV and HCH home ventilation units are primarily designed for 1 and 2 family houses. The units are supplied as packaged ventilation units complete with built-in demand-control and a control panel. The home ventilation units are fitted with highly efficient counter-flow heat exchangers which are optimised to a very high efficiency level thus achieving a very low specific fan power (SFP value) for the entire unit.

For a quick selection you can use the selection chart below. The selection chart shows the air volumes when operating with a normal duct system with normal pressure drop.

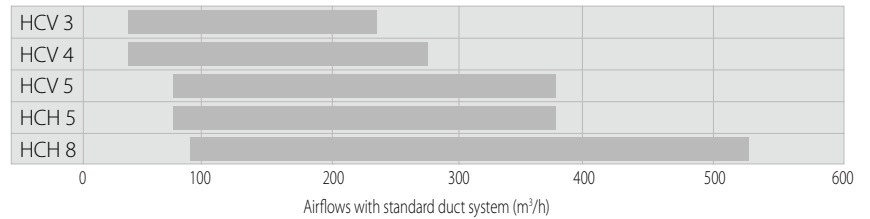

### HCV models

The HCV home ventilation units are vertical models designed for wall-mounting. They fulfil ventilation requirements of houses up to 260 m<sup>2</sup>, depending on national requirements and the actual pressure loss in the installation.

The HCV 3 and HCV 4 units are perfect for concealed installation in standard 60x60 cm cupboard modules, e.g. in a modern utility room environment, where everything is hidden behind doors. All ducts are connected to the top of the unit and on this model it is also possible to connect the supply duct to the base if ducts are to run beneath the floor.

The HCV 5 unit is ideal for installation side-by-side with standard 60x60 cm cupboard modules. If desired, the unit can be hidden behind a cupboard door, which can be facilitated by reducing the depth of the unit to 560 mm using a special wall mounting available as an accessory. On this model, all the duct connections are at the top of the unit.

### HCH models

The HCH home ventilation units are horizontal models designed to be fitted in the loft or on the floor of a plant room. They fulfil the ventilation requirements of houses up to app. 475 m<sup>2</sup>, depending on national requirements and the actual pressure loss in the installation.

Both HCH models have duct connections at the ends and service access at the front. Electrical connection is at the end of the unit facing the fresh air – right-hand – side. The ducts connected to the home (supply and extract) are always on the left-hand side of the unit. The condensation drain is located at the rear of the unit.

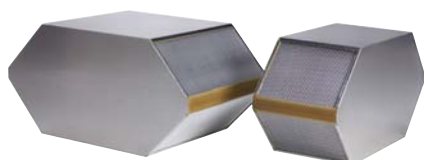

Dantherm counterflow  
heat exchanger



EC fan

### Certificates

The Dantherm HC home ventilation units are certified for usage in passive houses by PassivHaus Institut in Darmstadt, Germany. Furthermore they are DIBt LÜ-A20 certified by Deutsches Institut für Bautechnik in Berlin, Germany and tested in accordance with EN 308 by IGE in Stuttgart, Germany. Hereby it is proven that the units fulfil the most severe requirements with regards to energy efficiency, air tightness, filter class, sound level, insulation class, frost protection, safety and a lot more. Ask for the complete test reports at Dantherm Air Handling A/S.

### Function

Both the HCV and the HCH units are fitted as standard with automatic demand controls, which means that the relative air humidity in the house remains at a comfortable level at all times. The demand control system employs a humidity sensor built into the unit, which constantly monitors the relative humidity of the air extracted from the house, whereupon the installation regulates the air volume as required. This secures an optimum indoor climate, at the same time minimising energy consumption when activity levels in the house are low.

### Features

- Demand-controlled ventilation with integrated humidity sensor
- High efficiency – up to 95%
- EC motors with extremely low energy consumption (low SFP)
- Easy-to-install solution with pressure pipes for air volume measurement and adjustment on the unit.
- HCV models are suitable for installation in 60x60 cm cupboards

### Cabinet

The HCV models are made from extruded polystyrene (EPS) components with a minimum wall thickness of 32 mm, while the HCH models are made with 40 mm thick walls. This high class insulation permits location of the units in rooms with temperatures as low as  $-20^{\circ}\text{C}$ .

The HC series complies with European fire safety requirements as specified in EN 13501 class E. The leakage rate of the unit (internal and external) is  $<3\%$  as specified in EN 308. The entire unit is clad in 0.8 mm Aluzink panels and the HCV models are painted white in RAL 9010.

### Highly efficient aluminium counterflow heat exchanger

Heat recovery takes place in a highly efficient counterflow heat exchanger made of aluminium, customised by Dantherm to achieve optimum efficiency with the least possible loss of pressure in connection with the low air volumes used in housing.

### Fans

The entire HC series uses the latest EC (Electromagnetic Commutation) fan motor technology. I.e., use of modern motors and fan rotors which offer the very best in air technology and electrical efficiency. Thanks to the EC technology the bearings are the only moving parts to produce resistance and therefore the lifetime of these fans is approx. 10 years when mounted in a home ventilation unit. The fans are powered by 230V AC and the stepless speed control is facilitated by means of a 0-10 V signal from the control panel of the ventilation unit.



Panel filters



Pressure outlet on HCV



Adjustment

### Filters

All models use 50 mm G4 compact filters as standard for both supply air and extract air. This will cater for the majority of air cleaning needs. The advantage of compact filters is that they have a considerably larger filter surface area than fibrous filters and small bag-filters. The filter thus works for longer and under normal conditions, it will not need changing more often than twice a year, equivalent to the filter timer setting.

If necessary, F7 filters (pollen filters) are available as accessories, which ensure that allergens do not enter the home through the ventilation system.

### Installation

Measurement and adjustment of air volumes is done via pressure nozzles and potentiometers located behind the removable front panels of all models. A performance graph is adhered to the polystyrene front showing the pressure and air volumes the installer must use to determine the correct fan speeds. The label also has a space for the installer to write in the air volumes, the backpressure and fan speeds to which the system has been adjusted. (See below).

### Adjustment label

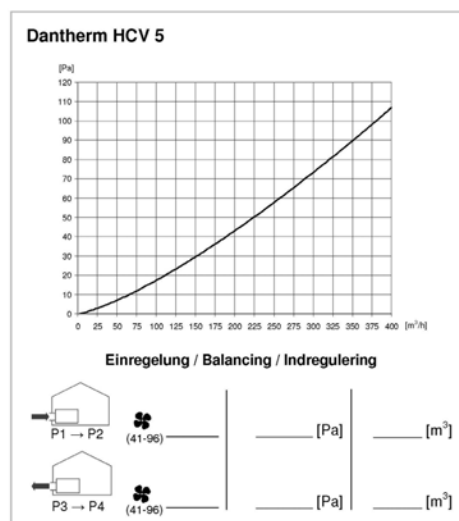



Operation via control panel

### Operation

The three wall-mounted models, HCV 3, HCV 4 and HCV 5 are operated via the integrated control panel, the location of which is ergonomically correct when the unit is installed at a height of approx. 2 metres.

The two horizontal models HCH 5 and HCH 8 are operated via the control panel, which is connected to the ventilation unit by a cable (2 m). It is recommended that the panel be fitted on a wall on the ground floor, e.g. in a back corridor or living room so that the status of the unit can be seen/heard and adjusted.

### Safety operation - Connection to a smoke or fire alarm system

It is possible to connect a standard smoke/fire alarm system to the HC home ventilation unit. The smoke/fire detection system must be connected to the accessory controller (HAC 1 accessory) at the fire protection terminals. When activated the alarm system will give a fire alarm signal and stop both fans to avoid more smoke/fire to enter from outside. Once the smoke/fire danger is no longer present the unit must be restarted manually by power off/on again.

When desired (due to higher risk of smoke/fire or higher safety requirements) it is possible also to build duct dampers into the duct work and have the ventilation unit open/close these whenever the unit is running/stopped. The damper motors (one for supply and one for extract air) can be powered and controlled by the HAC 1 accessory controller.

### Service and maintenance

In general, the only regular maintenance required by HC products is to check/change the air filters twice a year, when the alarm LED blinks yellow and the acoustic alarm bleeps once an hour.

On HCV models, the user changes the filter by opening the top-hinged lid, changing the filters and resetting the filter timer with the button next to the filters.

On the HCH models, the front panel is removed, after which the two filters can be changed and the filter timer reset.

Apart from changing the air filters and cleaning the outside of the unit, any other form of service will have to be carried out by qualified personnel. Local Dantherm technicians and Dantherm partners are always available to solve any problem with the unit that might arise.



Changing the HCV filter



Changing the HCH filter



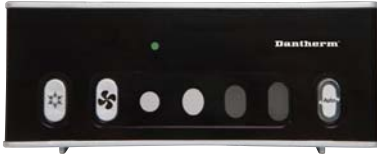

Control panel (HCP 4)



Adjustment of air flow on the control panel

## CONTROL

### Control strategies

In practice, the fact that the HC units have demand control automation means that you never need to touch the system once it has been installed and adjusted. However, it is possible to disable demand control and thus manually determine the fan speed or manually activate the bypass module in order to get fresh air cooling here and now if the need should arise.

The installation is always secured against incorrect and uneconomical operation over a longer period. This is because several of the functions return to default after 4 hours. This prevents inconvenient excessive energy consumption if you e.g. forget that you have set the unit to full speed or manual bypass. If you switch off the installation it automatically restarts after 4 hours, so you can be sure that your home will be properly ventilated and that condensation will not form in the ducts and in the unit.

During adjustment, fan speed no. 3 is set on the control panel to the nominal air volume the house requires under normal usage. This is done by adjusting the potentiometers (fan steps 46-91 out of 100 steps are available).

The correlation between the four fan speeds on the control panel is as follows:

- Fan speed 0 = both fans stopped for 4 hours.
- Fan speed 1 = 50\* steps slower than fan speed 3
- Fan speed 2 = 25\* steps slower than fan speed 3
- Fan speed 3 = Nominal air change, adjustment using potentiometers
- Fan speed 4 = Max.\* fan speed

\*These factory settings can be adjusted from the remote control

When the installation is set to demand control it never runs faster than the adjusted air volume at step 3. This avoids unnecessary inconvenience in special situations during which external factors would otherwise cause the installation to run at maximum air volume.

### Control panel

The drawing below shows the buttons, LEDs and sound outlets on the control panel which is included with the unit and the remote control which is an optional accessory.

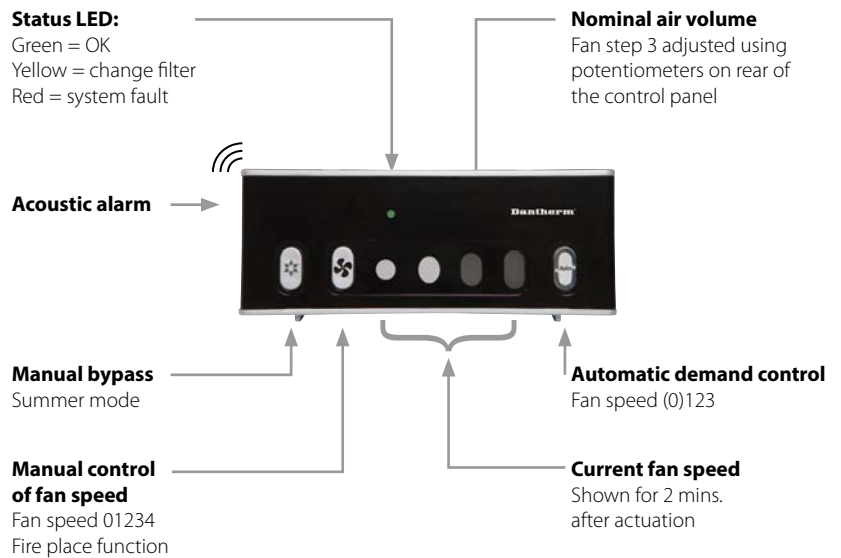

### Wireless remote control

With an optional remote control the user gets access to week program operation, away operation, night operation, and reading of outdoor temperature, supply air temperature, extract air temperature, supply air temperature, extract air temperature and room temperature, air humidity and CO2 levels.

Wireless remote control, HRC 2 (accessory)

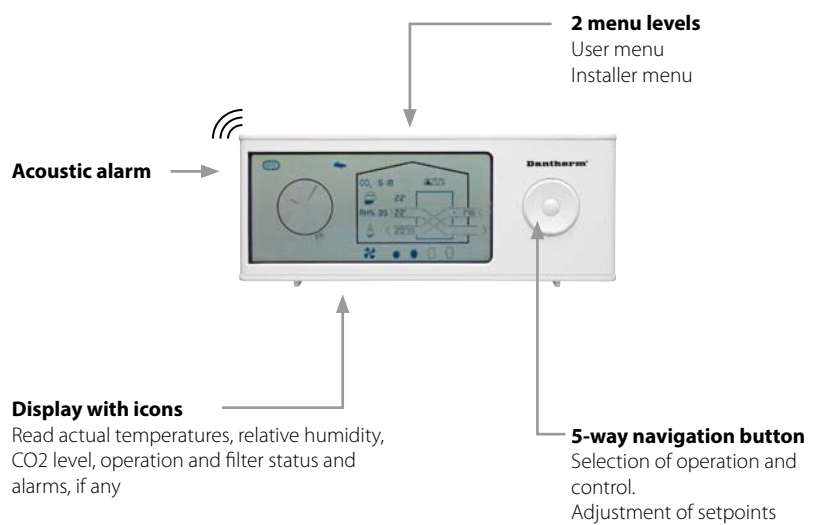



Bypass-module for HCH

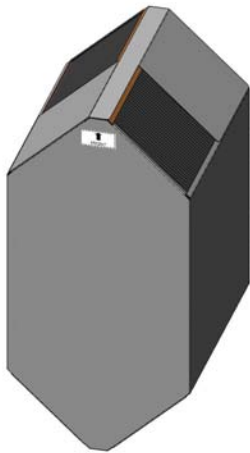

Bypass shunt

### **Bypass cooling - Automatic bypass function**

All models in the HC series are fitted with a bypass module, with the exception of the HCV 3 and HCV 4. The bypass module is regulated automatically and exploits the cold outdoor air to cool down the home, e.g. after a hot summer's day, when the night time temperature outdoors falls below the temperature of the house. The bypass module leads all the hot exhaust air past the heat exchanger in order to achieve the best possible cooling effect.

In order for the unit automatically to open the bypass module, the hot extract temperature (T3) must be  $24^{\circ}\text{C}^*$ , and the outdoor air (T1)  $15^{\circ}\text{C}^*$ . The outdoor air (T1) must also be  $2^{\circ}\text{C}$  colder than the hot extract temperature (T3).\*

These factory settings can be adjusted from the remote control.

### **Manual bypass function**

In addition to the system providing cooling by means of the automatic bypass function, there is also a manual bypass function which can be activated by the user whenever required. This function keeps the bypass module open for 6 hours, on condition that the warm extract temperature (T3) is  $15^{\circ}\text{C}$ , the outdoor temperature (T1) is above  $2^{\circ}\text{C}$  and the outdoor air (T1) is  $2^{\circ}\text{C}$  colder than the hot extract temperature (T3).

### **Bypass shunt - HCV 3 and HCV 4**

In order to avoid heat recovery the unit is recommended to be periodically fitted with the by-pass shunt. This need occurs when indoor temperature rises above an acceptable level and where lower outdoor temperature still can meet normal comfort demands. By-pass shunt is a non-automatic thermal by-pass facility which has to be mounted onto the heat exchanger manually in the beginning of summer period, where a need for especially night-cooling appears. As a result, a dwelling is supplied with fresh and filtrated outdoor air, which improves indoor climate.

A manual removal of by-pass shunt is correspondingly necessary when heating season starts again to avoid cold draft and to ensure normal heat recovery and energy savings.

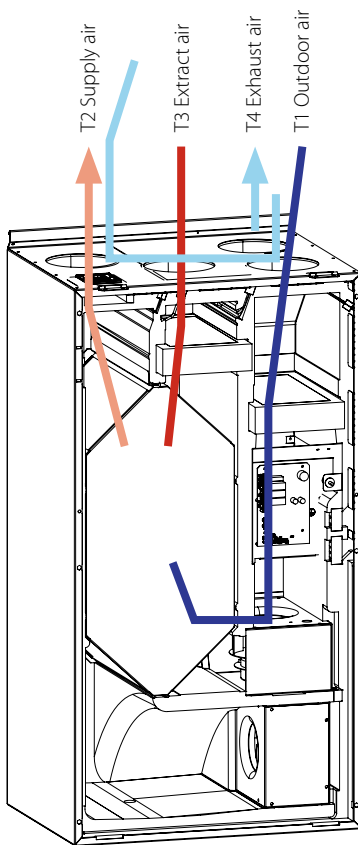

### Frost protection of the heat exchanger

The intelligent control system of the HC systems ensures that the heat exchanger does not ice up. Frost protection is activated if the exhaust air temperature (T4) is  $< +2^{\circ}\text{C}$ , which will usually occur when the outdoor air temperature (T1) falls below approx.  $-6^{\circ}\text{C}$ .

When the exhaust temperature (T4) falls to  $+2^{\circ}\text{C}$ , the system reduces the volume of supply air (T2) so that the final exhaust temperature (T4) is maintained at minimum  $+2^{\circ}\text{C}$ . If it is particularly cold, the supply air volume will be turned right down to  $0\text{ m}^3/\text{h}$  for short intervals in order to keep the heat exchanger frost-free. If the outdoor air temperature (T1) falls below  $< -13^{\circ}\text{C}$  for more than five minutes, the system stops completely for 30 mins. in order to stop it icing up.

In areas where the outdoor temperatures often is lower than  $-6^{\circ}\text{C}$ , we recommend to mount pre-heating. In other areas, where the outdoor temperature may fall below  $-10^{\circ}\text{C}$ , preheating is a must for obtaining a balanced and reliable solution.

### Frost protection of water based heating coil

In order to protect the water based after heating coil (when mounted) against frost, the unit stops for 30 min., if the supply air temperature (T2) is  $< +5^{\circ}\text{C}$ .

### Filter control

Because backpressure in the filter is expected to increase and thus reduce air volumes during the period preceding a filter change, this is compensated for by the two fans running faster and faster until the filter alarm sounds/lights up and the filter timer is reset.

TECHNICAL DATA

Model		HCV 3	HCV 4	HCV 5	HCH 5	HCH 8
<b>Performance</b>						
Max. air flow	m <sup>3</sup> /h	230	275	375	375	530
Energy consumption class (SEC-class): average climate		A				
Energy consumption class (SEC-class): average climate		A <sup>+1)</sup>				
Heat exchanger type		Dantherm Alu. counterflow heat exchanger				
Temperature efficiency		Up to 95% <sup>2)</sup>				
Bypass		No		Yes		
Filter class supply/exhaust, standard		G4/G4				
Surrounding temperature where the unit is installed	°C	+10 to +50			-20 to +50	
Operational temperature range without pre-heating	°C	-13 <sup>3)</sup> to + 50				
Operational temperature range with pre-heating	°C	- 30 to + 50				
<b>Cabinet</b>						
Height	mm	1005	1005	1055	600	600
Width	mm	530	530	590	1180	1180
Depth (Standard mounting rail/rail for plan mounting)	mm	434/419	434/419	584/569	580	780
Duct connection	mm	125	125	160	160	250
Weight, unit	kg	33	32	45	52	70
Weight including packaging	kg	41	42	57	66	84
Dimensions including packaging and pallet (HxWxD)	mm	H: 675	H: 675	H: 735	H: 750	H: 775
		W: 1070	W: 1070	W: 1120	W: 1210	W: 1200
		D: 435	D: 435	D: 600	D: 610	D: 800
Outer cabinet material		Aluzink				
Colour	RAL	9010			Aluzink grey	
Cabinet insulation, polystyrene	mm	32			40	
Insulation factor, cabinet	W/m <sup>2</sup> x °K	0,97			0,78	
Fire classification, polystyrene cabinet		DIN 4102 class B1				
Fire classification, the whole unit		EN 13501 class E				
Protection class	IP	20				
<b>Electrical data</b>						
Integrated control panel HCP 4 in front		Yes			No	
Separate HCP 4 control panel included + 2 m cable		No			Yes	
Supply voltage		1x230 V, 50 Hz				
Max. current consumption, without pre- and after-heat	A	0,4	0,4	0,7	0,7	1,1
Max. power consumption, without pre- and after-heat	W	88	88	154	154	246

1. Requires an Energy Efficiency Class A+ kit (including CO2 sensor and HAC 1 accessory control). Described under Accessories.
2. Condensing operation.
3. We recommend preheating at temperatures under -6°C to ensure a balanced operation.

**HCV 3 Sound data**

Flow m³/h	Pressure Pa	Measure Point	Frequency band sound power Lw dB(A)							Total sound power Lw dB(A)	Sound pressure Standard room* Lp dB(A)
			63Hz	125Hz	250Hz	500Hz	1000Hz	2000Hz	4000Hz		
140	70	Supply air duct	34	40	43	44	36	27	19	57	
		Extract air duct	35	38	40	44	41	33	24	56	
		Cabinet									47
	100	Supply air duct	36	42	45	47	38	29	21	59	
		Extract air duct	37	40	43	47	43	33	26	58	
		Cabinet	20	32	39	42	39	34	24		49
180	100	Supply air duct	38	42	47	50	48	42	31	61	
		Extract air duct	38	43	50	51	48	42	31	61	
		Cabinet	38	41	45	48	46	40	29		55

\* Standard room = room with 10 m² floor, 2,4 m ceiling height, mean absorption 0,2.

**HCV 4 Sound data**

Flow m³/h	Pressure Pa	Measure Point	Frequency band sound power Lw dB(A)								Total sound power Lw dB(A)	Sound pressure Standard room* Lp dB(A)
			63Hz	125Hz	250Hz	500Hz	1000Hz	2000Hz	4000Hz	8000Hz		
126	70	Supply air duct	20	30	41	42	38	30	19	18	46	
		Extract air duct	18	30	41	41	30	26	18	18	44	
		Cabinet	27	34	48	46	43	40	27	19		47
	100	Supply air duct	22	32	46	45	39	32	21	18	49	
		Extract air duct	22	33	43	42	32	27	19	18	46	
		Cabinet	32	38	50	49	46	41	32	22		50
162	70	Supply air duct	23	31	43	46	41	33	22	18	49	
		Extract air duct	26	31	42	43	33	29	21	18	46	
		Cabinet	38	40	49	54	52	44	33	20		53
	100	Supply air duct	28	33	44	48	43	35	23	18	51	
		Extract air duct	29	34	44	51	37	31	23	18	52	
		Exhaust air duct	32	43	46	46	38	31	31	19	50	
Cabinet	46	42	47	56	52	44	34	21		55		
216	70	Supply air duct	28	33	44	54	46	37	28	18	55	
		Extract air duct	27	33	43	52	39	33	27	18	52	
		Cabinet	34	39	47	57	54	49	39	24		57
	100	Supply air duct	28	35	45	55	46	38	29	18	56	
		Extract air duct	32	34	44	52	40	34	28	18	53	
		Cabinet	40	38	47	60	53	48	39	23		56

\* Standard room = room with 10 m² floor, 2,4 m ceiling height, mean absorption 0,2.

**HCV 5 Sound data**

Flow m <sup>3</sup> /h	Pressure Pa	Measure Point	Frequency band sound power Lw dB(A)								Total sound power Lw dB(A)	Sound pressure Standard room* Lp dB(A)
			63Hz	125Hz	250Hz	500Hz	1000Hz	2000Hz	4000Hz	8000Hz		
126	50	Supply air duct	20	30	34	36	23	19	17	18	40	
		Extract air duct	16	31	37	36	29	21	17	18	40	
		Cabinet	18	32	37	38	37	32	21	19		39
162	70	Supply air duct	23	33	35	40	32	24	18	18	43	
		Extract air duct	20	33	44	39	34	26	18	18	46	
		Cabinet	22	34	42	41	42	38	24	19		44
	100	Supply air duct	25	36	42	42	34	28	18	18	46	
		Extract air duct	21	33	43	41	35	28	18	18	46	
		Cabinet	25	36	45	44	44	41	26	19		46
216	70	Supply air duct	25	34	42	42	35	28	19	18	46	
		Extract air duct	22	34	44	43	37	31	20	18	47	
		Cabinet	24	35	47	44	45	42	29	20		47
	100	Supply air duct	26	36	43	44	36	30	20	18	47	
		Extract air duct	23	34	45	44	33	32	20	18	48	
		Exhaust air duct	35	42	59	49	49	44	33	20	60	
Cabinet	25	36	50	46	46	44	30	20		49		
250	100	Supply air duct	27	36	45	45	38	31	21	18	49	
		Extract air duct	24	37	47	45	40	34	22	18	50	
		Cabinet	26	38	53	47	48	46	33	22		53

\* Standard room = room with 10 m<sup>2</sup> floor, 2,4 m ceiling height, mean absorption 0,2.

**HCH 5 Sound data**

Flow m <sup>3</sup> /h	Pressure Pa	Measure Point	Frequency band sound power Lw dB(A)								Total sound power Lw dB(A)	Sound pressure Standard room* Lp dB(A)
			63Hz	125Hz	250Hz	500Hz	1000Hz	2000Hz	4000Hz	8000Hz		
162	70	Supply air duct	23	34	40	36	29	25	17	18	42	
		Extract air duct	23	33	39	37	29	24	18	18	42	
		Cabinet	22	31	39	41	31	29	23	21		40
	100	Supply air duct	25	35	43	38	31	28	18	18	45	
		Extract air duct	25	36	42	39	40	25	17	18	45	
		Cabinet	23	34	41	42	33	31	24	21		41
216	70	Supply air duct	26	36	44	39	33	30	19	18	46	
		Extract air duct	28	36	43	41	34	29	18	18	46	
		Cabinet	28	35	45	44	37	35	27	21		45
	100	Supply air duct	26	37	44	40	34	31	19	18	47	
		Extract air duct	27	37	45	42	35	30	19	18	48	
		Exhaust air duct	34	43	52	52	47	51	38	21	57	
Cabinet	26	34	46	45	38	36	28	21		46		
250	100	Supply air duct	28	39	46	42	37	33	21	18	49	
		Extract air duct	30	39	48	45	38	33	20	18	50	
		Cabinet	28	36	50	48	41	39	32	22		49

\* Standard room = room with 10 m<sup>2</sup> floor, 2,4 m ceiling height, mean absorption 0,2.

**HCH 8 Sound data**

Flow m <sup>3</sup> /h	Pressure Pa	Measure Point	Frequency band sound power Lw dB(A)								Total sound power Lw dB(A)	Sound pressure Standard room* Lp dB(A)
			63Hz	125Hz	250Hz	500Hz	1000Hz	2000Hz	4000Hz	8000Hz		
350	100	Supply air duct	44	51	56	50	43	38	23	7	63	
		Extract air duct	41	47	48	46	41	36	23	2	59	
		Cabinet	26	37	52	43	40	37	23	17		52
450	100	Supply air duct	39	48	62	55	52	50	37	22	67	
		Extract air duct	39	47	61	55	53	48	37	20	66	
		Cabinet	38	46	60	52	50	47	36	22		61

\* Standard room = room with 10 m<sup>2</sup> floor, 2,4 m ceiling height, mean absorption 0,2.



### HCV 3 Capacity & SFP curves

(with radial fans, G4/G4 filters)

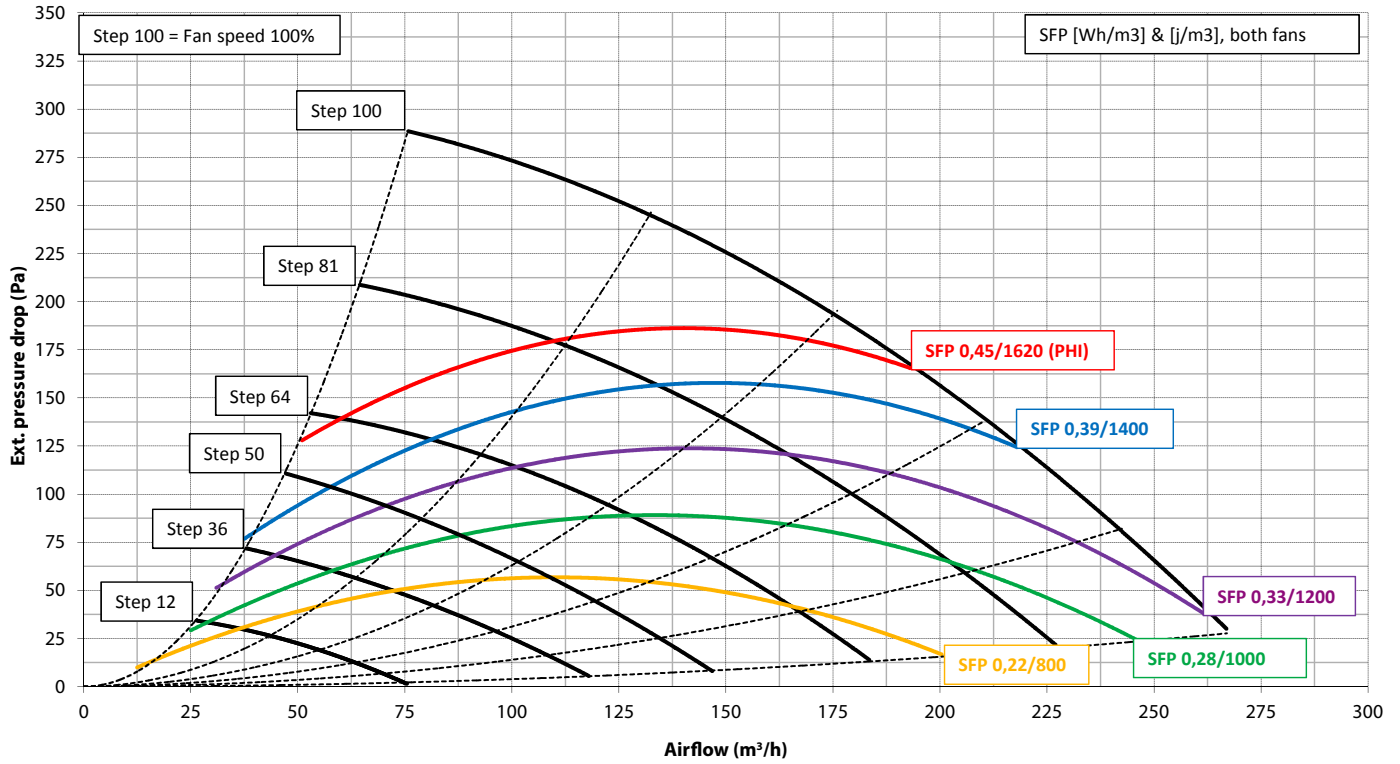

### HCV 3 Temperature efficiency

- Temperature efficiency with condensate.  
 Extract air = 25°C/55%RH  
 Outdoor air = -10°C/50%RH  
 Balanced mass flow.
- Temperature efficiency (DiBt).  
 Extract air = 21°C/37%RH  
 Outdoor air = -3°C/85%RH  
 Balanced mass flow.
- Temperature efficiency (Passivhaus)  
 Extract air = 21°C/32%RH  
 Outdoor air = +4°C/90%RH  
 Balanced mass flow.

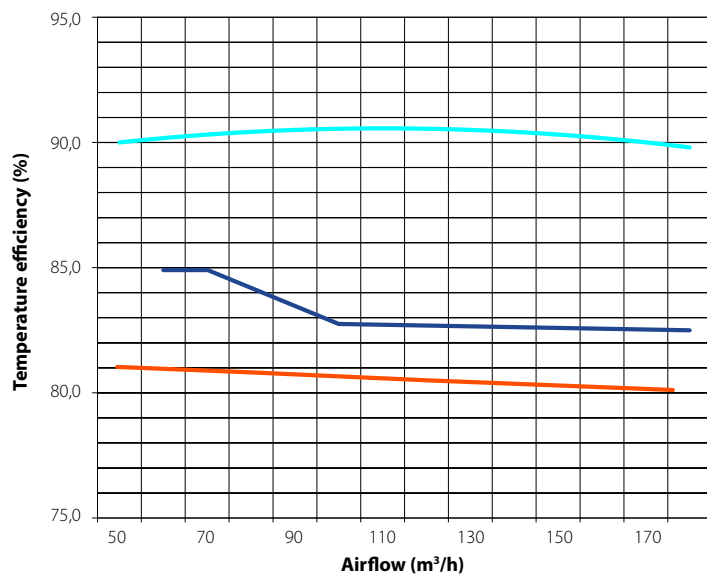

**HCV 4 Capacity & SFP curves**

(with Radial 133 mm fans, G4/G4 filters)

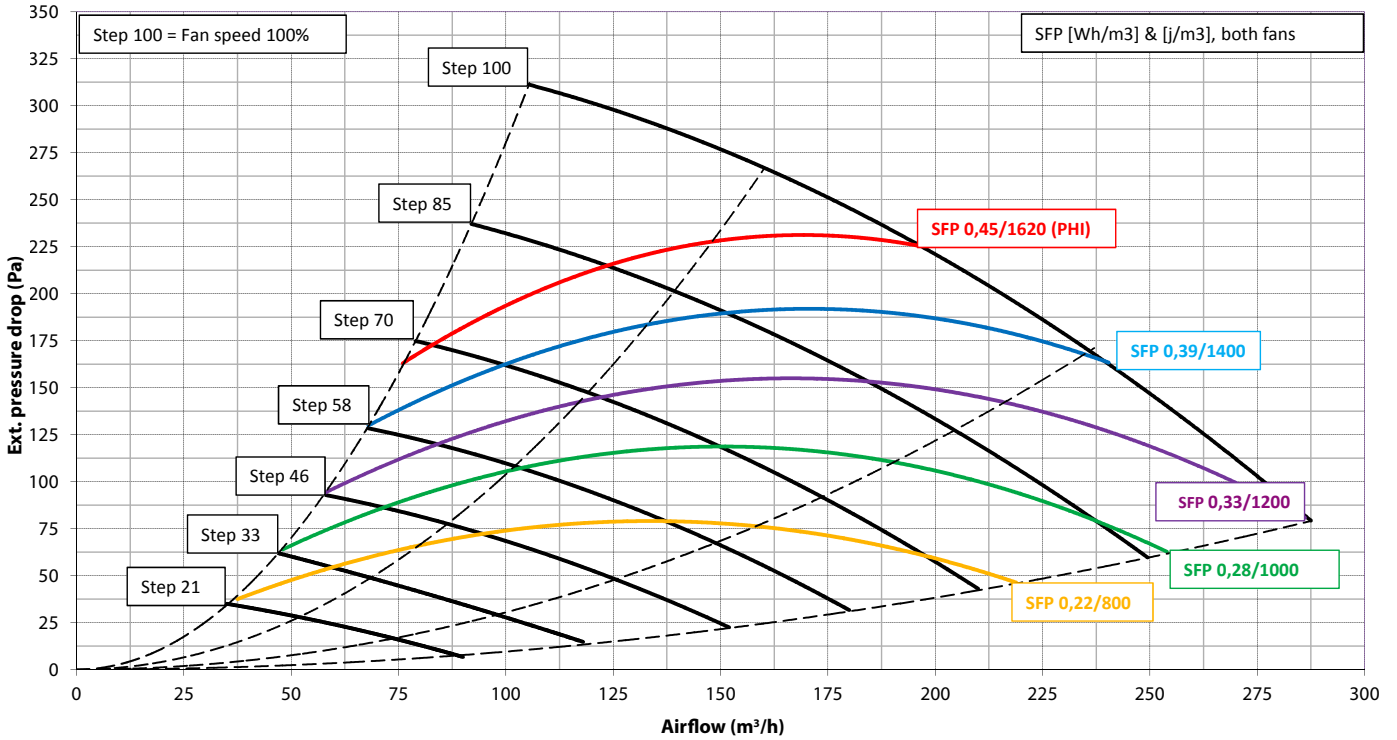

**HCV 4 Temperature efficiency**

- Temperature efficiency with condensate.  
 Extract air = 25°C/55%RH  
 Outdoor air = -10°C/50%RH  
 Balanced mass flow.
- Temperature efficiency (EN308).  
 Extract air = 25°C/25%RH  
 Outdoor air = +5°C/95%RH  
 Balanced mass flow.

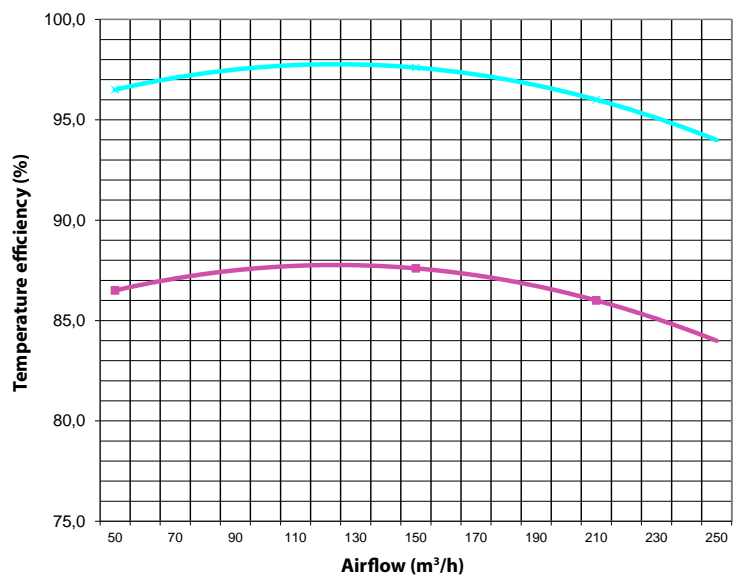

### HCV 5 Capacity & SFP curves

(with RadiCal fans, G4/G4 filters)

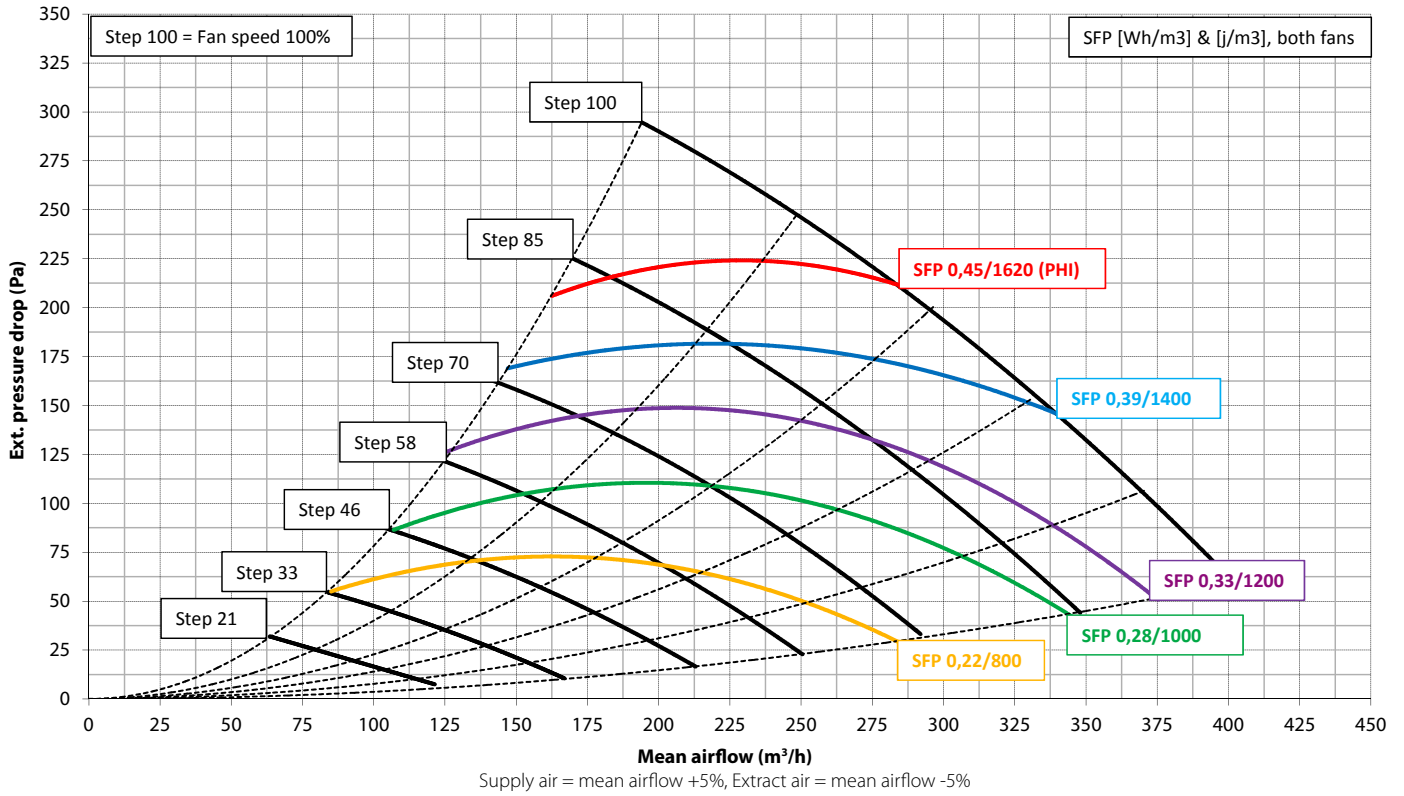

### HCV 5 Temperature efficiency

- Temperature efficiency with condensate.  
 Extract air = 25°C/55%RH  
 Outdoor air = -10°C/50%RH  
 Balanced mass flow.
- Temperature efficiency (DiBt).  
 Extract air = 21°C/37%RH  
 Outdoor air = -3°C/85%RH  
 Balanced mass flow.
- Temperature efficiency (Passivhaus)  
 Extract air = 21°C/32%RH  
 Outdoor air = +4°C/90%RH  
 Balanced mass flow.

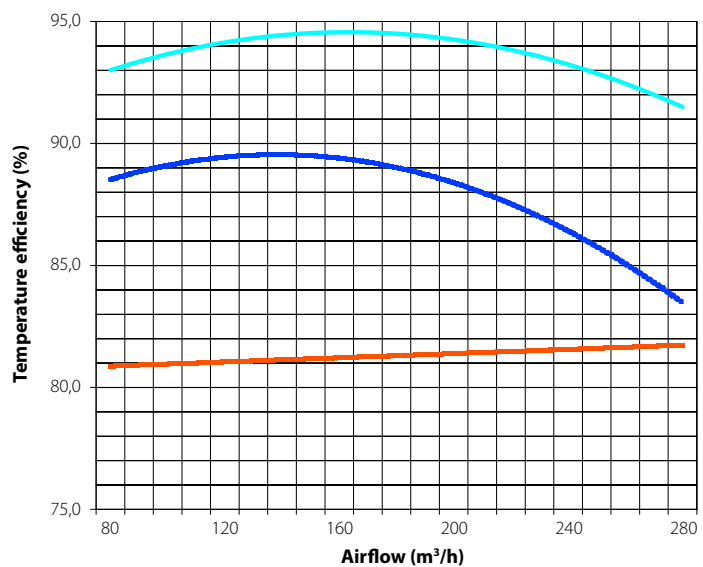

**HCH 5 Capacity & SFP curves**

(with RadiCal fans, G4/G4 filters)

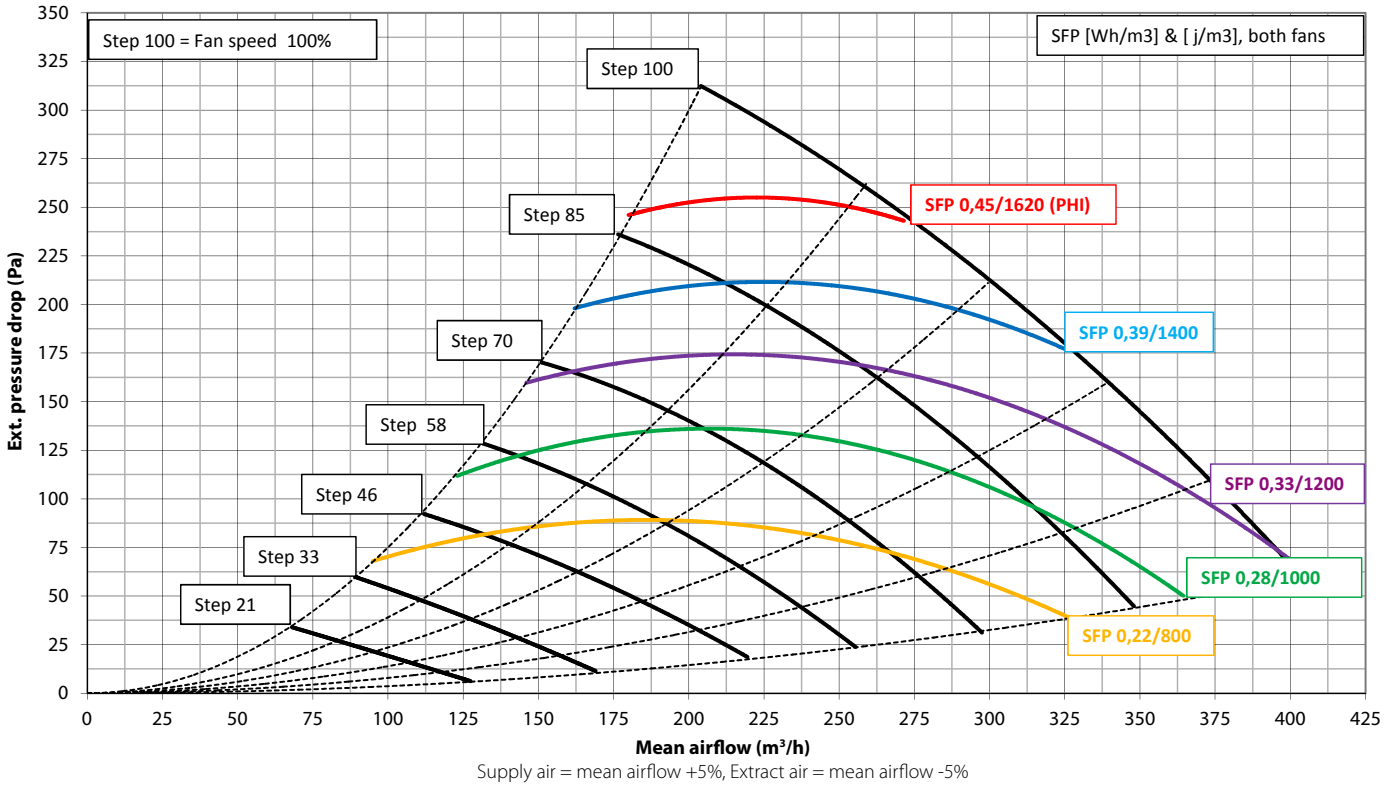

**HCH 5 Temperature efficiency**

- Temperature efficiency with condensate.  
Extract air = 25°C/55%RH  
Outdoor air = -10°C/50%RH  
Balanced mass flow.
- Temperature efficiency (DiBt).  
Extract air = 21°C/37%RH  
Outdoor air = -3°C/85%RH  
Balanced mass flow.
- Temperature efficiency (Passivhaus)  
Extract air = 21°C/32%RH  
Outdoor air = +4°C/90%RH  
Balanced mass flow.

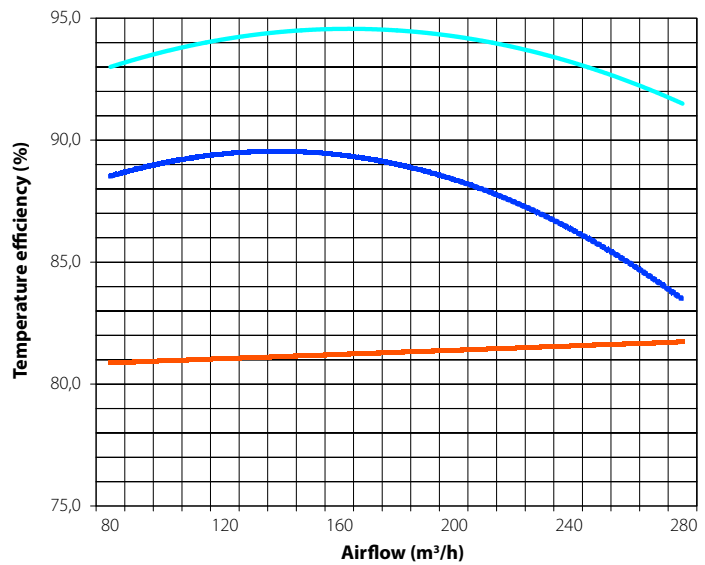

### HCH 8 Capacity & SFP curves

(with radial fans, G4/G4 filters)

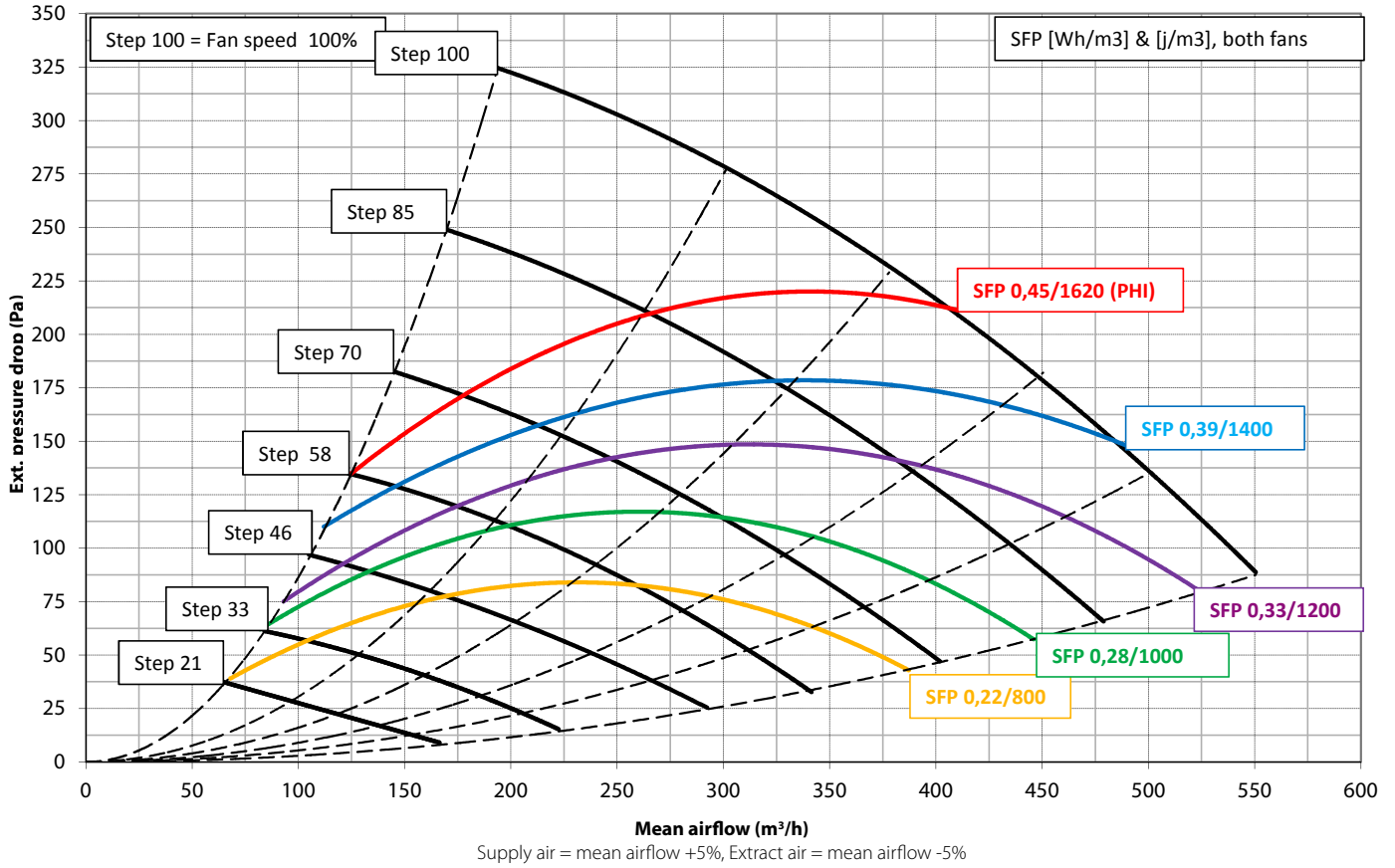

### HCH 8 Temperature efficiency

- Temperature efficiency with condensate.  
 Extract air = 25°C/55%RH  
 Outdoor air = -10°C/50%RH  
 Balanced mass flow.
- Temperature efficiency (DiBt).  
 Extract air = 21°C/37%RH  
 Outdoor air = -3°C/85%RH  
 Balanced mass flow.
- Temperature efficiency (Passivhaus)  
 Extract air = 21°C/32%RH  
 Outdoor air = +4°C/90%RH  
 Balanced mass flow.

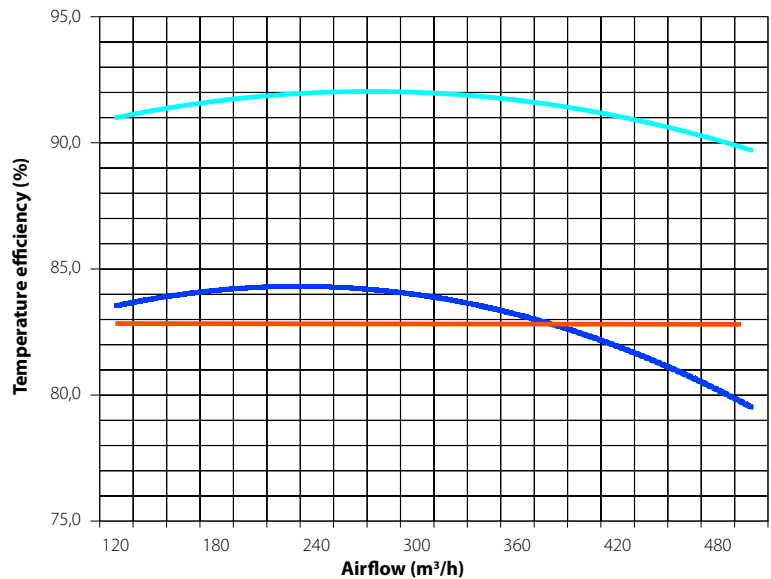



**HCV 3 Dimensions**

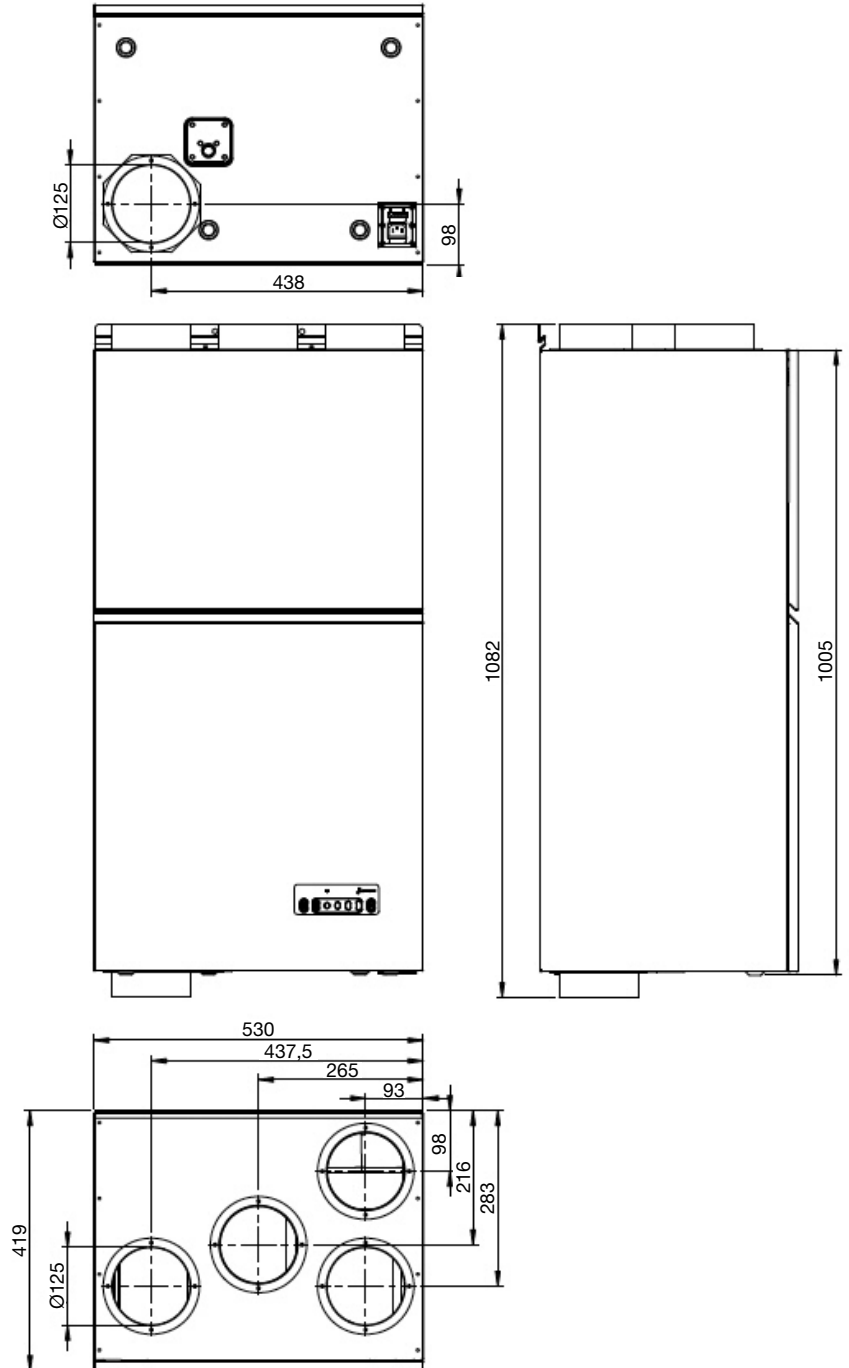



### HCV 4 Dimensions

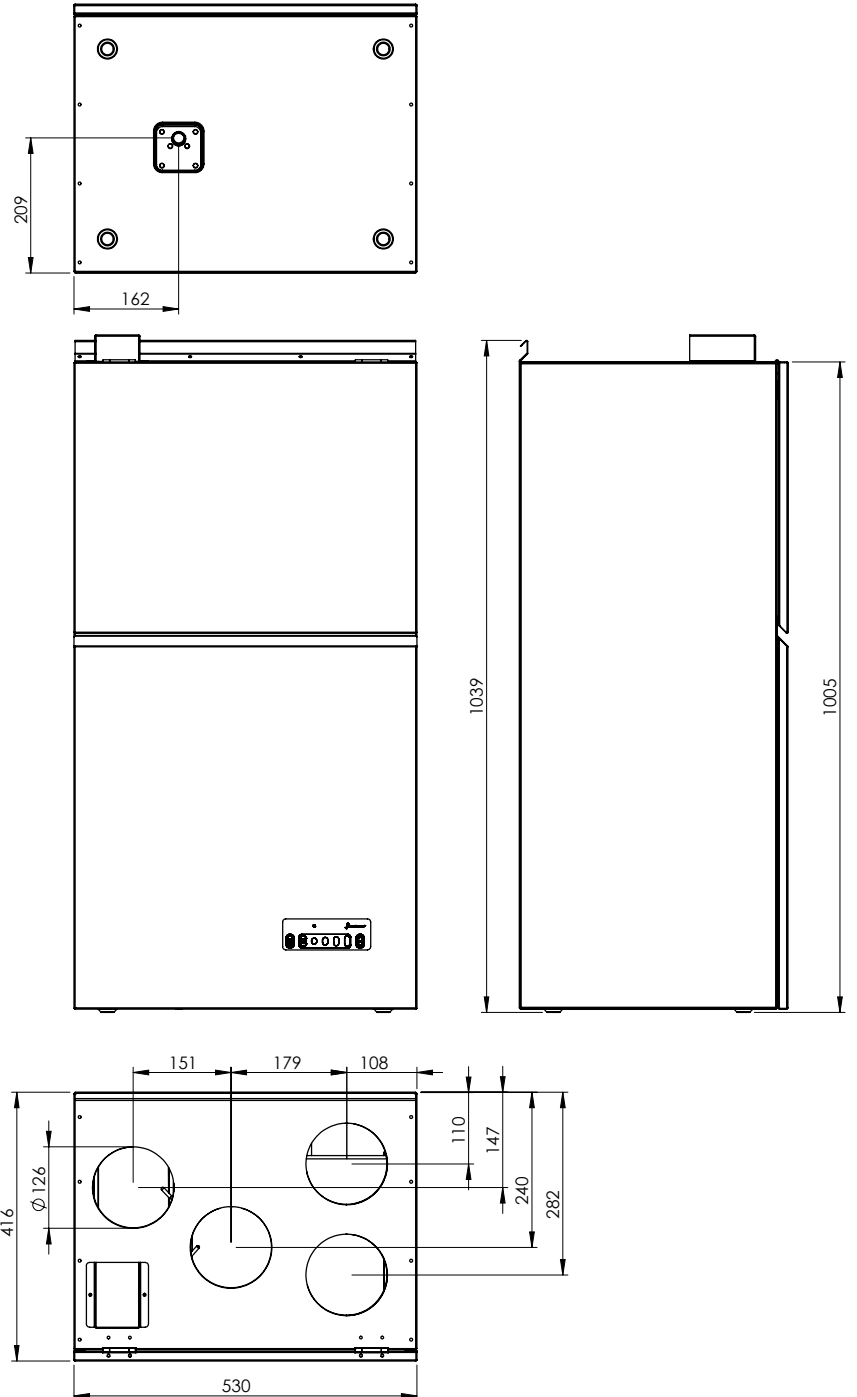

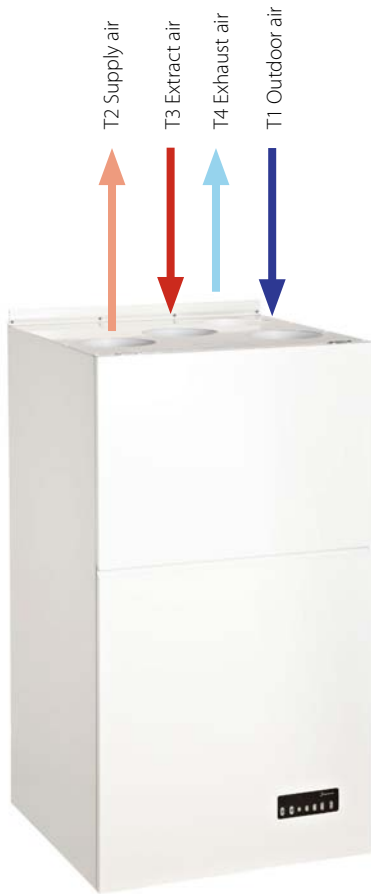

**HCV 5 Dimensions**

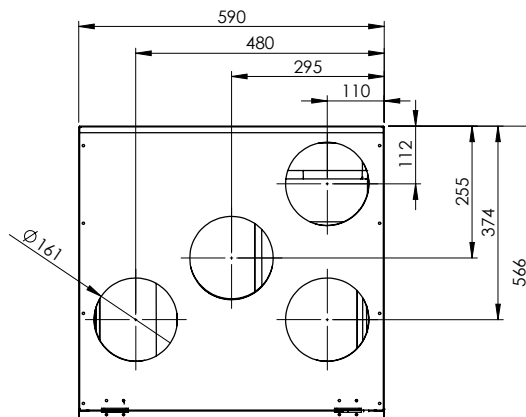
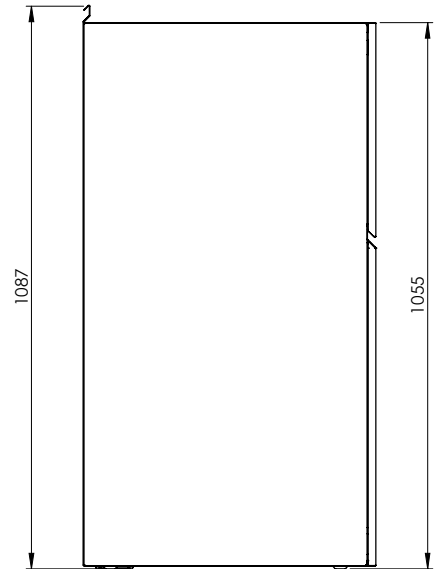
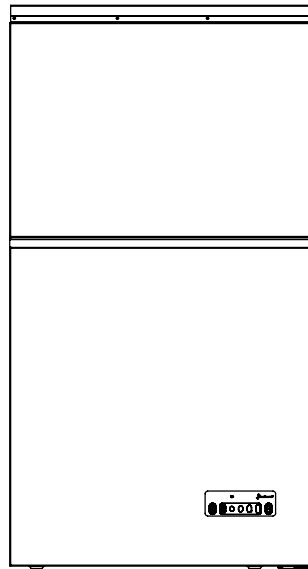
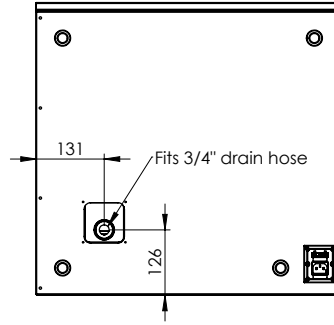



### HCH 5 Dimensions

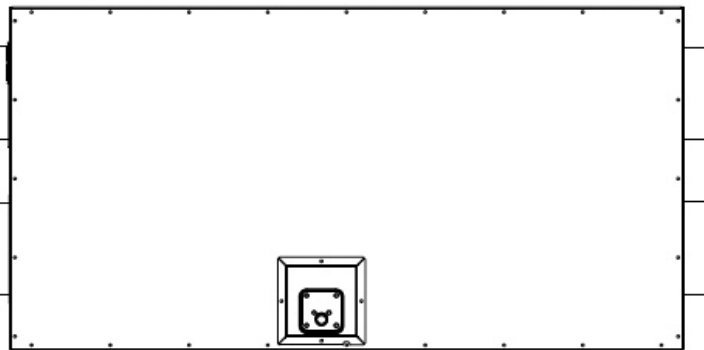
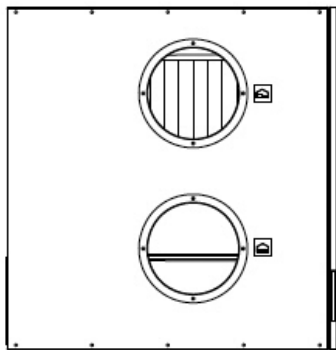
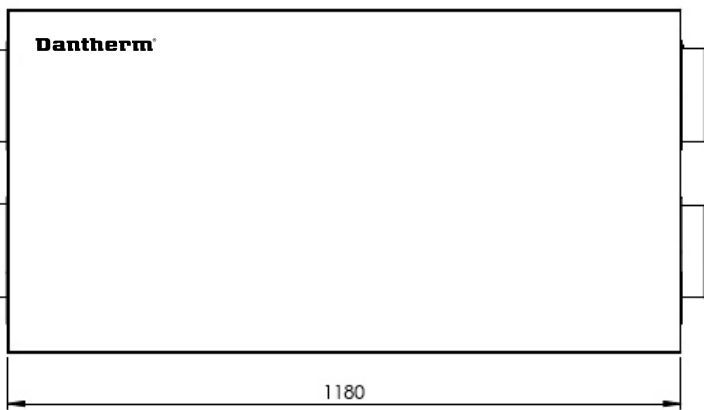
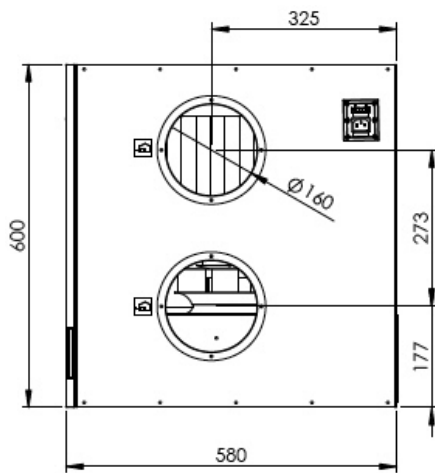

**HCH 8 Dimensions**

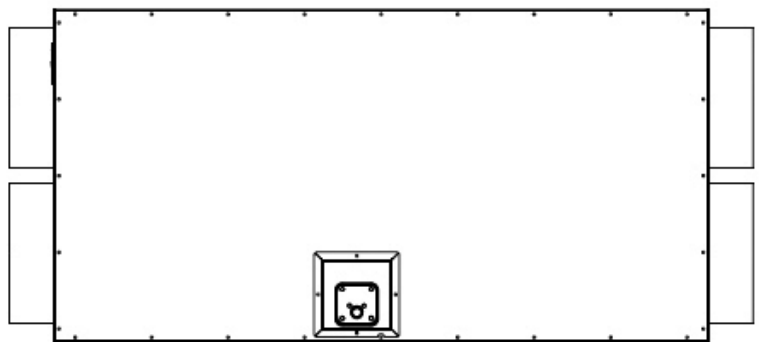
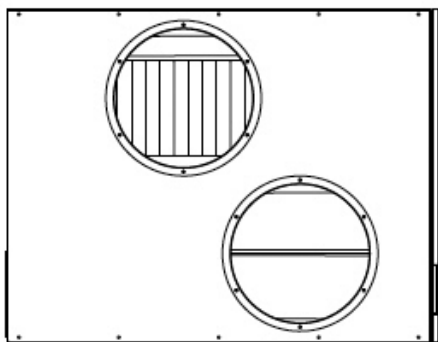
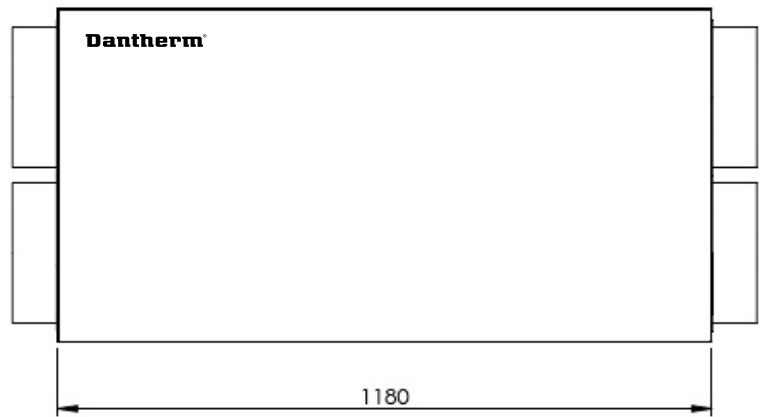
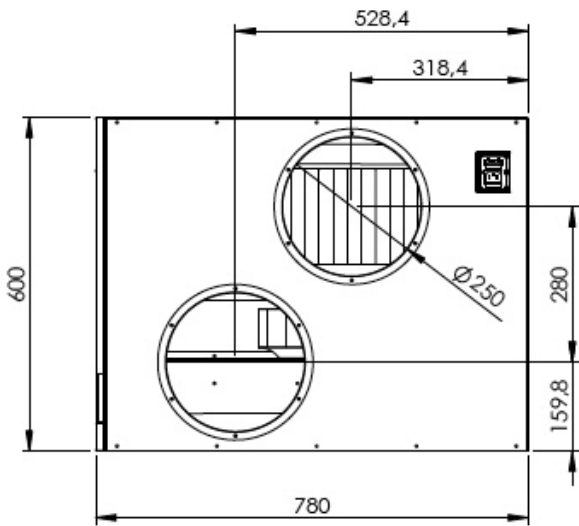



Wall mounting rail  
for plan installation



Siphon trap kit



Heat cable



Communication cable

## ACCESSORIES

### Wall mounting rail

Mounting rail for plan installation of HCV 5 behind the door in a cupboard. With this rail the installation depth will be reduced. Insulation tape (50x3 mm), vibration damper, and u-profile (19x5 mm) are included. Dimension: 526 mm x 30 mm.

### Siphon trap kit

Siphon trap kit including 2 m  $\frac{3}{4}$ " armed hose and glands.

### Heat cable, 3 m

Heat cable, 230V, 10W/m, including 5°C thermostat for frost protection of drain.

### Communication cable

Communication cable, 30 m extension, with plug for connection of control panel to the HCH/HCV unit.



Wireless remote control



Accessory control



Power supply



Hygrostat



CO2 sensor

**Wireless remote control, HRC 2**

The remote control gives access to:

- manual operation
- automatic demand-control
- week program operation
- away operation when you are absent for a longer period
- night operation
- reading of outdoor temperature, supply and extract air temperature, room temperature, relative humidity and CO2 level
- installer menu for adjustment and fault-finding

**Accessory control HAC 1**

Accessory control with connection of heating coils, cooling coils, geothermal collector, duct damper, stop function, fire thermostat, CO2 sensor, hygrostat and alarms, incl. 5 m cable.

Included in the Energy Efficiency Class A+ kit.

**Power supply 230VAC – 24VDC, for duct control**

Power supply to be mounted in the accessory control if the ventilation unit is controlling the duct damper.

**Hygrostat, Sauter HSC 120 F001**

The hygrostat is connected to the accessory control in case that a higher air change rate is required in rooms with high humidity.

**CO2 sensor**

The CO2 sensor is connected to the accessory control if the air change has to be controlled in accordance with the CO2 level in a given room.

Included in the Energy Efficiency Class A+ kit



Electric pre-/afterheating coil 0-10V.



Electric pre-/afterheating coil, direct control

### Heating coils for electricity

The electric heating coils are designed for installation in the supply or extract air duct. The heating coil is provided with duct connections with a rubber sealing gasket. The heating coil is not suitable for outdoor installation. The control current is connected to the accessory control HAC 1. Connection to supply voltage 230V is made separately.

### Electric pre-/after heating coil, 0-10V controlled by the accessory control

The heating coil is controlled by a stepless regulation via the accessory control HAC 1.

### Electric pre-/after heating coil, direct control by the built-in thermostat

The heating coil is controlled by the built-in thermostat. Both heating coils are supplied with a duct sensor.

Both heating coils are supplied with a duct sensor.

### Capacity, dimensions and weight

The electric heating coils are un-finned and therefore the resulting air pressure loss is negligible.

		HCV 3	HCV 4	HCV 5	HCH 5	HCH 8
Air volume	m <sup>3</sup> /h	180	220	300	300	450
Heat output	kW	0,9	0,9	1,2	1,2	1,8
Temperature rise	°C	16,8	13,7	14,2	14,2	13,4
Power consumption, 1x230V	A	4,1	4,1	5,5	5,5	8,2
Duct connection	Ø mm	125	125	160	160	250
Weight	Kg	3,0	3,0	3,5	3,5	5,0

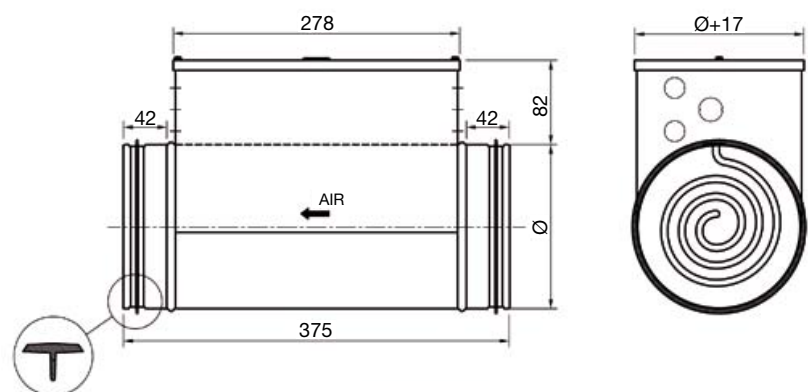



Water heating coil



Servo motor



2-way water valve



230/24 V AC trafo

### Water heating coils

The water heating coil kit includes 2RR, 2-way water valve, 0-10V servo motor, 230/24VAC trafo, duct sensor and tube sensor for frost protection. It is controlled by the accessory control HAC 1.

HCV 3 / HCV 4 (CWW 125-2-2.5)		Max. capacity						Supply air temperature 21°C					
		80°C/60°C			60°C/40°C			80°C/60°C			60°C/40°C		
Air volume	m <sup>3</sup> /h	85	150	215	85	150	215	85	150	215	85	150	215
Air temp. out*	°C	40	36	34	28	25	23	21	21	21	21	21	21
Pressure loss	Pa	11	28	51	11	28	51	11	28	51	11	28	51
Capacity	kW	0,7	1,1	1,4	0,4	0,5	0,6	0,2	0,3	0,5	0,2	0,3	0,5
Water flow	L/h	36	36	72	36	36	36	9	10	23	17	22	28
Pressure loss, max.	KPa	0,5	0,5	1	0,5	0,5	0,5	0,2	0,2	0,4	0,3	0,4	0,5

HCV 5/HCH 5 (CWW 160-2-2.5)		Max. capacity						Supply air temperature 21°C					
		80°C/60°C			60°C/40°C			80°C/60°C			60°C/40°C		
Air volume	m <sup>3</sup> /h	145	250	355	145	250	355	145	250	355	145	250	355
Air temp. out*	°C	47	43	40	33	31	29	21	21	21	21	21	21
Pressure loss	Pa	6	15	27	6	15	27	6	15	27	6	15	27
Capacity	kW	1,6	2,4	3,0	0,9	1,3	1,7	0,3	0,5	0,7	0,3	0,5	0,7
Water flow	L/h	72	108	144	36	72	72	14	24	35	12	28	30
Pressure loss, max.	KPa	1	3	4	0,5	1	2	0,2	0,4	0,5	0,1	0,4	0,5

HCH 8 (CWW 250-2-2.5)		Max. capacity				Supply air temperature 21°C			
		80°C/60°C		60°C/40°C		80°C/60°C		60°C/40°C	
Air volume	m <sup>3</sup> /h	360	630	360	630	360	630	360	630
Air temp. out*	°C	44	40	31	29	21	21	21	21
Pressure loss	Pa	10	25	10	25	10	25	10	25
Capacity	kW	3,6	5,3	2,0	3,0	0,74	1,29	0,74	1,28
Water flow	L/h	144	252	108	144	30	61	40	61
Pressure loss, max.	KPa	1	3	1	2	0,5	1,0	0,7	1,0

\*Air in 15°C

**Water heating coils, continued**

**Dimensions and weight**

	Ød	B	H	Ødy	F	G	K	L	Weight
	mm								
HCV 3 / HCV 4CWW 125-2-2.5	125	238	180	10	137	40	276	356	3,5
HCV 5 / HCH 5CWW 160-2-2.5	160	313	255	10	212	40	276	356	5,4
HCH 8CWW 250-2-2.5	250	398	330	10	250	40	276	356	7,7

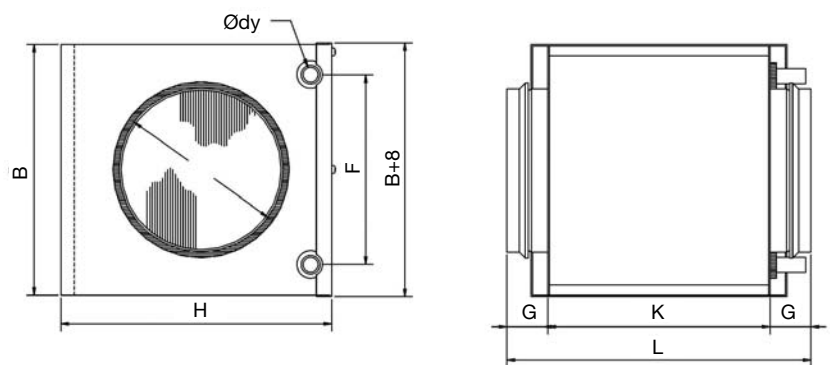

Filters

**Panel filters**

Panel filters are supplied as a set with either two G4 filters or one G4 filter and one F7 filter. G4 is standard. F7 filters can be used on the supply air as a pollen filter.

**ELECTRONICS COOLING**

**DEHUMIDIFICATION**

**VENTILATION**

**MOBILE HEATING AND COOLING**

Dantherm is a market-leading supplier of energy-efficient climate control solutions for customers across the globe. Our subsidiaries in Norway, Sweden, Germany, and the UK and our representative office in Russia unite approx. 240 employees. We operate in the following four main business areas:

**Electronics cooling:**

Climate control for electronics and battery cooling in radio base stations and other Telecom infrastructure. Telecom customers include network suppliers and network operators.

**Dehumidification:**

Mobile and stationary dehumidifiers for drying buildings and for use in private pools and wellness centres.

**Ventilation:**

Large ventilation systems used in swimming pools and buildings such as shopping centres and cinemas requiring frequent air change. The range also includes domestic ventilation products based on high-performance heat exchangers.

**Mobile heating and cooling:**

Products for heating or cooling of tents and equipment used by the armed forces and aid organisations. The customers are primarily the armed forces in NATO countries as well as tent and container manufacturers.

**Dantherm Air Handling A/S**

Marienlystvej 65  
DK-7800 Skive, Denmark  
Tel. +45 96 14 37 00  
Fax +45 96 14 38 20  
info@dantherm.com

