



Air Conditioners

Technical Data

VRV[®]

Ceiling mounted corner cassette



EEDEN11-204

FXKQ-MA



Air Conditioners

Technical Data



Ceiling mounted corner cassette



EEDEN11-204

FXKQ-MA

TABLE OF CONTENTS

FXKQ-MA

1	Specifications	2
	Technical Specifications	2
	Electrical Specifications	3
2	Safety device settings	4
	Safety Device Settings	4
3	Options	5
	Options	5
4	Control systems	6
	Control Systems	6
5	Capacity tables	7
	Cooling Capacity Tables	7
	Heating Capacity Tables	8
	Capacity Correction Factor	9
6	Dimensional drawings	10
	Dimensional Drawings	10
7	Centre of gravity	11
	Centre of Gravity	11
8	Piping diagrams	12
	Piping Diagrams	12
9	Wiring diagrams	13
	Wiring Diagrams - Single Phase	13
10	Sound data	14
	Sound Level Data	14
	Sound Pressure Spectrum	15
11	Air flow patterns	16
	Air Flow Pattern - Heating	16
12	Installation	17
	Drainage Instructions	17
	Suspension Bolt Pitch Position	19
	Service Space	20

1 Specifications

1-1 Technical Specifications				FXKQ25MA	FXKQ32MA	FXKQ40MA	FXKQ63MA
Cooling capacity	Nom.		kW	2.8 (1)	3.6 (1)	4.5 (1)	7.10 (1)
Heating capacity	Nom.		kW	3.2 (2)	4.0 (2)	5.0 (2)	8.00 (2)
Power input - 50Hz	Cooling	Nom.	kW	0.066		0.076	0.105
	Heating	Nom.	kW	0.046		0.056	0.085
Power input - 60Hz	Cooling	Nom.	kW	0.069		0.092	0.120
	Heating	Nom.	kW	0.049		0.072	0.100
Casing	Material			Galvanised steel plate			
Dimensions	Unit	Height	mm	215			
		Width	mm	1,110		1,310	
		Depth	mm	710			
Weight	Unit		kg	31			34
Decoration panel	Model			BYK45FJW1			BYK71FJW1
	Colour			White			
	Dimensions	Height	mm	70			
		Width	mm	1,240		1,440	
		Depth	mm	800			
Weight			kg	8.5			9.5
Heat exchanger	Type			Cross fin coil			
	Rows	Quantity		2			3
	Fin pitch		mm	1.75			
	Face area		m ²	0.180		0.226	
	Stages	Quantity		11			
Fan	Type			Sirocco fan			
	Quantity			1			
	Air flow rate - 50Hz	Cooling	High	m ³ /min	11	13	18
			Low	m ³ /min	9	10	15
	Air flow rate - 60Hz	Cooling	High	m ³ /min	11	13	18
Low			m ³ /min	8.5	10	13	
Fan motor	Quantity			1			
	Model			3D12H1AN1V1	3D12H1AP1V1	4D12H1AJ1V1	
	Output	High	W	15	20	45	
	Drive			Direct drive			
Sound pressure level	Cooling	High	dBA	38.0		40.0	42.0
		Low	dBA	33.0		34.0	37.0
Refrigerant	Type			R-410A			
	Control			Electronic expansion valve			
Piping connections	Liquid	Type		Flare connection			
		OD	mm	6.35		9.52	
	Gas	Type		Flare connection			
		OD	mm	12.7		15.9	
	Drain			VP25 (O.D. 32 / I.D. 25)			
Heat insulation			Foamed Polyethylene				
Temperature control				Microprocessor thermostat for cooling and heating			
Air filter				Resin net with mold resistance			
Safety devices	Item	01		Fuse			
		02		Fan motor thermal fuse			

Standard Accessories : Washer;

Standard Accessories : Air outlet blocking pad;

Standard Accessories : Drain hose;

Standard Accessories : Screws;

Standard Accessories : Sealing pads;

Standard Accessories : Insulation for fitting;

Standard Accessories : Clamp metal;

Standard Accessories : Positioning jig for installation;

Standard Accessories : Insulation for hanger bracket;

Standard Accessories : Clamps;

Standard Accessories : Paper pattern for installation;

Standard Accessories : Installation manual;

Standard Accessories : Operation manual;

1 Specifications

1-2 Electrical Specifications			FXKQ25MA	FXKQ32MA	FXKQ40MA	FXKQ63MA
Power supply	Name		VE			
	Phase		1~			
	Frequency	Hz	50/60			
	Voltage	V	220-240/220			
Voltage range	Min.	%	-10			
	Max.	%	10			
Current - 50Hz	Minimum circuit amps (MCA)		A	0.3		0.5
	Maximum fuse amps (MFA)		A	15		
	Full load amps (FLA)	Total	A	0.2		0.4
Current - 60Hz	Minimum circuit amps (MCA)		A	0.4	0.5	0.6
	Maximum fuse amps (MFA)		A	15		
	Full load amps (FLA)	Total	A	0.3	0.4	0.5

Notes

- (1) Cooling: indoor temp. 27°CDB, 19°CWB; outdoor temp. 35°CDB; equivalent piping length: 7.5m (horizontal)
- (2) Heating: indoor temp. 20°CDB; outdoor temp. 7°CDB, 6°CWB; equivalent refrigerant piping: 7.5m (horizontal)
- (3) Capacities are net, including a deduction for cooling (an addition for heating) for indoor fan motor heat.
- (4) Voltage range: units are suitable for use on electrical systems where voltage supplied to unit terminal is not below or above listed range limits.
- (5) Maximum allowable voltage range variation between phases is 2%.
- (6) MCA/MFA: $MCA = 1.25 \times FLA$
- (7) $MFA \leq 4 \times FLA$
- (8) Next lower standard fuse rating minimum 15A
- (9) Select wire size based on the value of MCA
- (10) Use a circuit breaker instead of a fuse.

2 Safety device settings

2 - 1 Safety Device Settings

FXKQ-MA

		Safety devices	25	32	40	63
FXKQ-MA	PC board fuse		250V 5A	250V 5A	250V 5A	250V 5A
	Fan motor thermal fuse	°C	146 ⁺³	146 ⁺³	-	-
	Fan motor thermal protector	°C	-	-	Off: 120 ⁺⁵ (On: 105 or less)	Off: 120 ⁺⁵ (On: 105 or less)
	Drain pump thermal fuse	°C	145	145	145	145

3D006691Q

3 Options

3 - 1 Options

	FXKQ25MA	FXKQ32MA	FXKQ40MA	FXKQ63MA
DECORATION PANEL		BYK45FJW1		BYK71FJW1
PANEL SPACER		KPBJS2F56W		KPBJS2F80W
LONG LIFE REPLACEMENT FILTER		KAFJ521F56		KAFJ521F80
AIR DISCHARGE GRILL		K-HV7AW		K-HV9AW
AIR DISCHARGE BLIND PANEL		KDBJS2F56W		KDBJS2F80W
FLEXIBLE DUCT (WITH SHUTTER)		KFDJ52F56		KFDJ52F80

3D037081A

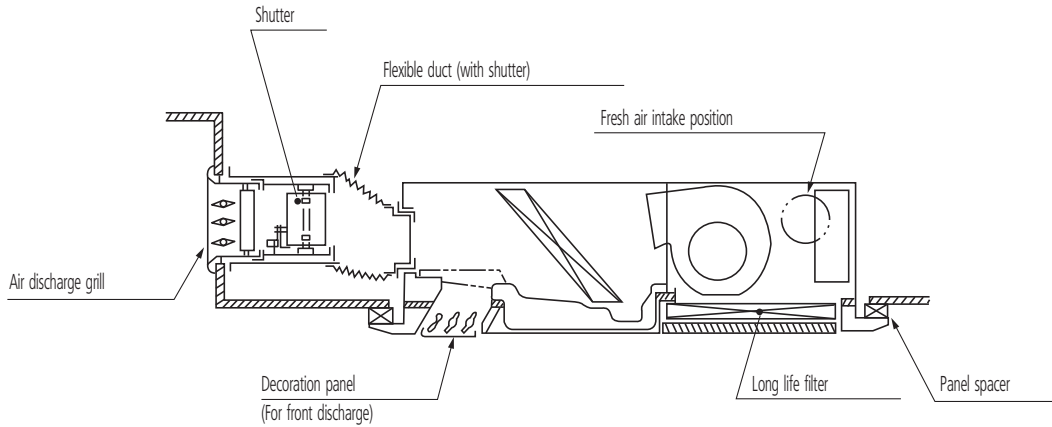

4 Control systems

4 - 1 Control Systems

FXKQ-MA

No.	Item	Type	FXKQ-MA	
1	Remote control	Infrared	H/P	BRC4C61
			C/O	BRC4C63
		Wired		BRC1D51 / BRC1E51A / BRC1D61 (1)
2	Simplified remote control		-	
3	Remote control for hotel use		-	
4	Adapter for wiring		KRP1B61	
5-1	Wiring adapter for electrical appendices (1)		KRP2A61	
5-1	Wiring adapter for electrical appendices (2)		KRP4A51	
6	Remote sensor		KRCS01-1	
7	Installation box for adapter PCB		-	
8	Central remote control		DCS302C51 / DCS302C61 (1)	
8-1	Electrical box with earth terminal (3 blocks)		KJB311A	
9	Unified on/off controller		DCS301B51 / DCS301B61 (1)	
9-1	Electrical box with earth terminal (2 blocks)		KJB212A	
9-2	Noise filter (for electromagnetic interface use only)		KEK26-1	
10	Schedule timer		DST301B51 / DST301B61 (1)	
11	External control adapter for outdoor unit (must be installed on indoor units)		DTA104A61	
12	Residential wired remote control		DCS303A51 (1) (2)	

3D034600D

NOTES

1. For DAME only.
2. For residential use only. Cannot be used with other centralised control equipment.

5 Capacity tables

5 - 1 Cooling Capacity Tables

FXKQ-MA																
Unit size	Nominal capacity	Outdoor air temp.	Indoor air temperature													
			14.OWB		16.OWB		18.OWB		19.OWB		20.OWB		22.OWB		24.OWB	
			20.ODB		23.ODB		26.ODB		27.ODB		28.ODB		30.ODB		32.ODB	
			°CDB	TC	SHC	TC	SHC	TC	SHC	TC	SHC	TC	SHC	TC	SHC	TC
25	2.8	10.0	1.9	1.9	2.3	2.2	2.6	2.3	2.8	2.4	3.0	2.5	3.4	2.5	3.7	2.5
		12.0	1.9	1.9	2.3	2.2	2.6	2.3	2.8	2.4	3.0	2.5	3.4	2.5	3.6	2.5
		14.0	1.9	1.9	2.3	2.2	2.6	2.3	2.8	2.4	3.0	2.5	3.4	2.5	3.6	2.5
		16.0	1.9	1.9	2.3	2.2	2.6	2.3	2.8	2.4	3.0	2.5	3.4	2.5	3.5	2.4
		18.0	1.9	1.9	2.3	2.2	2.6	2.3	2.8	2.4	3.0	2.5	3.4	2.5	3.5	2.4
		20.0	1.9	1.9	2.3	2.2	2.6	2.3	2.8	2.4	3.0	2.5	3.4	2.5	3.4	2.4
		21.0	1.9	1.9	2.3	2.2	2.6	2.3	2.8	2.4	3.0	2.5	3.4	2.5	3.4	2.4
		23.0	1.9	1.9	2.3	2.2	2.6	2.3	2.8	2.4	3.0	2.5	3.3	2.5	3.4	2.3
		25.0	1.9	1.9	2.3	2.2	2.6	2.3	2.8	2.4	3.0	2.5	3.3	2.5	3.3	2.3
		27.0	1.9	1.9	2.3	2.2	2.6	2.3	2.8	2.4	3.0	2.5	3.2	2.4	3.3	2.3
		29.0	1.9	1.9	2.3	2.2	2.6	2.3	2.8	2.4	3.0	2.5	3.2	2.4	3.2	2.3
		31.0	1.9	1.9	2.3	2.2	2.6	2.3	2.8	2.4	3.0	2.5	3.1	2.4	3.2	2.3
		33.0	1.9	1.9	2.3	2.2	2.6	2.3	2.8	2.4	3.0	2.5	3.1	2.4	3.1	2.3
		35.0	1.9	1.9	2.3	2.2	2.6	2.3	2.8	2.4	3.0	2.5	3.0	2.4	3.1	2.3
		37.0	1.9	1.9	2.3	2.2	2.6	2.3	2.8	2.4	2.9	2.5	3.0	2.4	3.0	2.3
		39.0	1.9	1.9	2.3	2.2	2.6	2.3	2.8	2.4	2.9	2.5	2.9	2.3	3.0	2.2
32	3.6	10.0	2.4	2.2	2.9	2.5	3.4	2.6	3.6	2.7	3.8	2.9	4.3	2.9	4.7	2.9
		12.0	2.4	2.2	2.9	2.5	3.4	2.6	3.6	2.7	3.8	2.9	4.3	2.9	4.7	2.9
		14.0	2.4	2.2	2.9	2.5	3.4	2.6	3.6	2.7	3.8	2.9	4.3	2.9	4.6	2.9
		16.0	2.4	2.2	2.9	2.5	3.4	2.6	3.6	2.7	3.8	2.9	4.3	2.9	4.6	2.8
		18.0	2.4	2.2	2.9	2.5	3.4	2.6	3.6	2.7	3.8	2.9	4.3	2.9	4.5	2.8
		20.0	2.4	2.2	2.9	2.5	3.4	2.6	3.6	2.7	3.8	2.9	4.3	2.9	4.4	2.8
		21.0	2.4	2.2	2.9	2.5	3.4	2.6	3.6	2.7	3.8	2.9	4.3	2.9	4.4	2.7
		23.0	2.4	2.2	2.9	2.5	3.4	2.6	3.6	2.7	3.8	2.9	4.2	2.9	4.3	2.7
		25.0	2.4	2.2	2.9	2.5	3.4	2.6	3.6	2.7	3.8	2.9	4.2	2.8	4.3	2.7
		27.0	2.4	2.2	2.9	2.5	3.4	2.6	3.6	2.7	3.8	2.9	4.1	2.8	4.2	2.7
		29.0	2.4	2.2	2.9	2.5	3.4	2.6	3.6	2.7	3.8	2.9	4.1	2.8	4.2	2.6
		31.0	2.4	2.2	2.9	2.5	3.4	2.6	3.6	2.7	3.8	2.9	4.0	2.7	4.1	2.6
		33.0	2.4	2.2	2.9	2.5	3.4	2.6	3.6	2.7	3.8	2.9	3.9	2.7	4.0	2.6
		35.0	2.4	2.2	2.9	2.5	3.4	2.6	3.6	2.7	3.8	2.9	3.9	2.7	4.0	2.6
		37.0	2.4	2.2	2.9	2.5	3.4	2.6	3.6	2.7	3.7	2.8	3.8	2.7	3.9	2.6
		39.0	2.4	2.2	2.9	2.5	3.4	2.6	3.6	2.7	3.7	2.8	3.8	2.7	3.8	2.6
40	4.5	10.0	3.0	2.6	3.6	2.8	4.2	3.2	4.5	3.2	4.8	3.3	5.4	3.5	5.9	3.5
		12.0	3.0	2.6	3.6	2.8	4.2	3.2	4.5	3.2	4.8	3.3	5.4	3.5	5.8	3.5
		14.0	3.0	2.6	3.6	2.8	4.2	3.2	4.5	3.2	4.8	3.3	5.4	3.5	5.8	3.4
		16.0	3.0	2.6	3.6	2.8	4.2	3.2	4.5	3.2	4.8	3.3	5.4	3.5	5.7	3.4
		18.0	3.0	2.6	3.6	2.8	4.2	3.2	4.5	3.2	4.8	3.3	5.4	3.5	5.6	3.3
		20.0	3.0	2.6	3.6	2.8	4.2	3.2	4.5	3.2	4.8	3.3	5.4	3.5	5.5	3.3
		21.0	3.0	2.6	3.6	2.8	4.2	3.2	4.5	3.2	4.8	3.3	5.4	3.5	5.5	3.3
		23.0	3.0	2.6	3.6	2.8	4.2	3.2	4.5	3.2	4.8	3.3	5.3	3.4	5.4	3.2
		25.0	3.0	2.6	3.6	2.8	4.2	3.2	4.5	3.2	4.8	3.3	5.2	3.4	5.3	3.2
		27.0	3.0	2.6	3.6	2.8	4.2	3.2	4.5	3.2	4.8	3.3	5.2	3.3	5.3	3.2
		29.0	3.0	2.6	3.6	2.8	4.2	3.2	4.5	3.2	4.8	3.3	5.1	3.3	5.2	3.1
		31.0	3.0	2.6	3.6	2.8	4.2	3.2	4.5	3.2	4.8	3.3	5.0	3.2	5.1	3.1
		33.0	3.0	2.6	3.6	2.8	4.2	3.2	4.5	3.2	4.8	3.3	4.9	3.2	5.0	3.1
		35.0	3.0	2.6	3.6	2.8	4.2	3.2	4.5	3.2	4.7	3.3	4.9	3.2	5.0	3.0
		37.0	3.0	2.6	3.6	2.8	4.2	3.2	4.5	3.2	4.7	3.3	4.8	3.1	4.9	3.0
		39.0	3.0	2.6	3.6	2.8	4.2	3.2	4.5	3.2	4.6	3.2	4.7	3.1	4.8	3.0
63	7.1	10.0	4.8	4.0	5.7	4.5	6.6	5.0	7.1	5.1	7.6	5.2	8.5	5.4	9.3	5.6
		12.0	4.8	4.0	5.7	4.5	6.6	5.0	7.1	5.1	7.6	5.2	8.5	5.4	9.2	5.5
		14.0	4.8	4.0	5.7	4.5	6.6	5.0	7.1	5.1	7.6	5.2	8.5	5.4	9.1	5.4
		16.0	4.8	4.0	5.7	4.5	6.6	5.0	7.1	5.1	7.6	5.2	8.5	5.4	9.0	5.3
		18.0	4.8	4.0	5.7	4.5	6.6	5.0	7.1	5.1	7.6	5.2	8.5	5.4	8.8	5.3
		20.0	4.8	4.0	5.7	4.5	6.6	5.0	7.1	5.1	7.6	5.2	8.5	5.4	8.7	5.2
		21.0	4.8	4.0	5.7	4.5	6.6	5.0	7.1	5.1	7.6	5.2	8.5	5.4	8.7	5.2
		23.0	4.8	4.0	5.7	4.5	6.6	5.0	7.1	5.1	7.6	5.2	8.4	5.3	8.5	5.1
		25.0	4.8	4.0	5.7	4.5	6.6	5.0	7.1	5.1	7.6	5.2	8.3	5.3	8.4	5.0
		27.0	4.8	4.0	5.7	4.5	6.6	5.0	7.1	5.1	7.6	5.2	8.1	5.2	8.3	5.0
		29.0	4.8	4.0	5.7	4.5	6.6	5.0	7.1	5.1	7.6	5.2	8.0	5.1	8.2	4.9
		31.0	4.8	4.0	5.7	4.5	6.6	5.0	7.1	5.1	7.6	5.2	7.9	5.1	8.1	4.9
		33.0	4.8	4.0	5.7	4.5	6.6	5.0	7.1	5.1	7.6	5.2	7.8	5.0	7.9	4.8
		35.0	4.8	4.0	5.7	4.5	6.6	5.0	7.1	5.1	7.5	5.2	7.7	5.0	7.8	4.8
		37.0	4.8	4.0	5.7	4.5	6.6	5.0	7.1	5.1	7.4	5.1	7.5	4.9	7.7	4.8
		39.0	4.8	4.0	5.7	4.5	6.6	5.0	7.1	5.1	7.2	5.0	7.4	4.9	7.6	4.7

TC: Total capacity;kW - SHC: Sensible capacity;kW

CA03A095

5 Capacity tables

5 - 2 Heating Capacity Tables

FXKQ-MA									
Unit Size	Nominal capacity	Outdoor air temperature		Indoor air temperature °CDB					
				16.0	18.0	20.0	21.0	22.0	24.0
		°CDB	°CWB	kW	kW	kW	kW	kW	kW
25	3.2	-19.8	-20.0	1.9	1.9	1.9	1.9	1.9	1.9
		-18.8	-19.0	1.9	1.9	1.9	1.9	1.9	1.9
		-16.7	-17.0	2.1	2.1	2.0	2.0	2.0	2.0
		-14.7	-15.0	2.2	2.2	2.2	2.2	2.2	2.1
		-12.6	-13.0	2.3	2.3	2.3	2.3	2.3	2.3
		-10.5	-11.0	2.4	2.4	2.4	2.4	2.4	2.4
		-9.5	-10.0	2.5	2.4	2.4	2.4	2.4	2.4
		-8.5	-9.1	2.5	2.5	2.5	2.5	2.5	2.5
		-7.0	-7.6	2.6	2.6	2.6	2.6	2.6	2.6
		-5.0	-5.6	2.7	2.7	2.7	2.7	2.7	2.7
		-3.0	-3.7	2.8	2.8	2.8	2.8	2.8	2.8
		0.0	-0.7	3.0	3.0	3.0	3.0	3.0	2.8
		3.0	2.2	3.1	3.1	3.1	3.1	3.0	2.8
		5.0	4.1	3.3	3.2	3.2	3.1	3.0	2.8
		7.0	6.0	3.4	3.4	3.2	3.1	3.0	2.8
		9.0	7.9	3.5	3.4	3.2	3.1	3.0	2.8
11.0	9.8	3.6	3.4	3.2	3.1	3.0	2.8		
13.0	11.8	3.6	3.4	3.2	3.1	3.0	2.8		
15.0	13.7	3.6	3.4	3.2	3.1	3.0	2.8		
32	4.0	-19.8	-20.0	2.4	2.4	2.3	2.3	2.3	2.3
		-18.8	-19.0	2.4	2.4	2.4	2.4	2.4	2.4
		-16.7	-17.0	2.6	2.6	2.6	2.6	2.6	2.5
		-14.7	-15.0	2.7	2.7	2.7	2.7	2.7	2.7
		-12.6	-13.0	2.9	2.8	2.8	2.8	2.8	2.8
		-10.5	-11.0	3.0	3.0	3.0	3.0	3.0	3.0
		-9.5	-10.0	3.1	3.1	3.1	3.1	3.0	3.0
		-8.5	-9.1	3.1	3.1	3.1	3.1	3.1	3.1
		-7.0	-7.6	3.2	3.2	3.2	3.2	3.2	3.2
		-5.0	-5.6	3.4	3.4	3.4	3.4	3.4	3.4
		-3.0	-3.7	3.5	3.5	3.5	3.5	3.5	3.5
		0.0	-0.7	3.7	3.7	3.7	3.7	3.7	3.5
		3.0	2.2	3.9	3.9	3.9	3.9	3.7	3.5
		5.0	4.1	4.1	4.1	4.0	3.9	3.7	3.5
		7.0	6.0	4.2	4.2	4.0	3.9	3.7	3.5
		9.0	7.9	4.3	4.3	4.0	3.9	3.7	3.5
11.0	9.8	4.5	4.3	4.0	3.9	3.7	3.5		
13.0	11.8	4.5	4.3	4.0	3.9	3.7	3.5		
15.0	13.7	4.5	4.3	4.0	3.9	3.7	3.5		
40	5.0	-19.8	-20.0	3.0	2.9	2.9	2.9	2.9	2.9
		-18.8	-19.0	3.0	3.0	3.0	3.0	3.0	3.0
		-16.7	-17.0	3.2	3.2	3.2	3.2	3.2	3.2
		-14.7	-15.0	3.4	3.4	3.4	3.4	3.4	3.4
		-12.6	-13.0	3.6	3.6	3.6	3.5	3.5	3.5
		-10.5	-11.0	3.7	3.7	3.7	3.7	3.7	3.7
		-9.5	-10.0	3.8	3.8	3.8	3.8	3.8	3.8
		-8.5	-9.1	3.9	3.9	3.9	3.9	3.9	3.9
		-7.0	-7.6	4.0	4.0	4.0	4.0	4.0	4.0
		-5.0	-5.6	4.2	4.2	4.2	4.2	4.2	4.2
		-3.0	-3.7	4.4	4.4	4.4	4.4	4.4	4.4
		0.0	-0.7	4.7	4.6	4.6	4.6	4.6	4.4
		3.0	2.2	4.9	4.9	4.9	4.8	4.7	4.4
		5.0	4.1	5.1	5.1	5.0	4.8	4.7	4.4
		7.0	6.0	5.2	5.2	5.0	4.8	4.7	4.4
		9.0	7.9	5.4	5.3	5.0	4.8	4.7	4.4
11.0	9.8	5.6	5.3	5.0	4.8	4.7	4.4		
13.0	11.8	5.6	5.3	5.0	4.8	4.7	4.4		
15.0	13.7	5.6	5.3	5.0	4.8	4.7	4.4		
63	8.0	-19.8	-20.0	4.7	4.7	4.7	4.7	4.7	4.7
		-18.8	-19.0	4.9	4.9	4.8	4.8	4.8	4.8
		-16.7	-17.0	5.1	5.1	5.1	5.1	5.1	5.1
		-14.7	-15.0	5.4	5.4	5.4	5.4	5.4	5.4
		-12.6	-13.0	5.7	5.7	5.7	5.7	5.7	5.7
		-10.5	-11.0	6.0	6.0	6.0	6.0	6.0	5.9
		-9.5	-10.0	6.1	6.1	6.1	6.1	6.1	6.1
		-8.5	-9.1	6.3	6.3	6.2	6.2	6.2	6.2
		-7.0	-7.6	6.5	6.5	6.4	6.4	6.4	6.4
		-5.0	-5.6	6.8	6.7	6.7	6.7	6.7	6.7
		-3.0	-3.7	7.0	7.0	7.0	7.0	7.0	7.0
		0.0	-0.7	7.5	7.4	7.4	7.4	7.4	7.0
		3.0	2.2	7.9	7.8	7.8	7.7	7.5	7.0
		5.0	4.1	8.1	8.1	8.0	7.7	7.5	7.0
		7.0	6.0	8.4	8.4	8.0	7.7	7.5	7.0
		9.0	7.9	8.7	8.5	8.0	7.7	7.5	7.0
11.0	9.8	8.9	8.5	8.0	7.7	7.5	7.0		
13.0	11.8	9.0	8.5	8.0	7.7	7.5	7.0		
15.0	13.7	9.0	8.5	8.0	7.7	7.5	7.0		

CA03A095

5 Capacity tables

5 - 3 Capacity Correction Factor

FXKQ-MA

		Single module and 2 module systems (not applicable for 3 module systems)						
		20°CDB 14°CWB	23°CDB 16°CWB	26°CDB 18°CWB	27°CDB 19°CWB	28°CDB 20°CWB	30°CDB 22°CWB	32°CDB 24°CWB
25	TC ratio	0,556	0,570	0,578	0,615	0,648	0,699	0,741
	SHF ratio	1,118	1,210	1,274	1,214	1,170	1,113	1,085
32	TC ratio	0,555	0,570	0,578	0,616	0,648	0,699	0,741
	SHF ratio	1,118	1,210	1,274	1,215	1,170	1,113	1,085
40	TC ratio	0,557	0,572	0,579	0,616	0,648	0,703	0,746
	SHF ratio	1,107	1,198	1,273	1,214	1,169	1,111	1,078
63	TC ratio	0,553	0,567	0,581	0,618	0,651	0,700	0,742
	SHF ratio	1,126	1,219	1,271	1,211	1,167	1,125	1,106

4TW27232-9

NOTES - ANMERKUNGEN - Σημειώσεις - NOTAS - REMARQUES - NOTE - OPMERKINGEN - Примечания - NOTLAR

How to use this table - So verwenden Sie diese Tabelle - Πώς θα χρησιμοποιήσετε αυτό τον πίνακα - Cómo utilizar esta tabla - Utilisation de ce tableau - Come utilizzare questa tabella - Gebruik van deze tabel - Как пользоваться этой таблицей - Bu tablo nasıl kullanılmalı?:

1. Capacity : Total capacity for High sensible mode = Total capacity for normal capacity table X TC ratio.

Leistung: Gesamtleistung für hochfühlbaren Leistungsmodus = Gesamtleistung für normale Leistungstabelle x GL-Verhältnis.

Απόδοση: Συνολική απόδοση για τη λειτουργία υψηλής ευαισθησίας = Συνολική απόδοση για τον πίνακα κανονικών αποδόσεων X αναλογία TC

Capacidad: Capacidad total para el modo de alta sensibilidad = Capacidad total para la tabla de capacidad normal X relación TC.

Capacité sensible (FCS (Facteur de chaleur sensible) – en anglais : SHF) : FCS pour le mode sensibilité élevée (« High ») = FCS du tableau des capacités normales x rapport FCS.

Capacità: Capacità totale per modalità ad alta capacità sensibile = Capacità totale per tabella capacità normali X rapporto TC.

Capaciteit: totale capaciteit in modus grote ("High") gevoeligheid = totale capaciteit uit de tabel met normale capaciteiten x TC-ratio.

Производительность: Общая производительность для режима с высоким коэфф. оцутимого охлаждения = Общая производительность для нормального режима, таблица X коэфф. TC.

Kapasite: Yüksek algı modu için toplam kapasite = Normal kapasite tablosundaki toplam kapasite değeri x TC oranı.

2. Sensible capacity (SHF): SHF for High sensible mode = SHF for normal capacity table X SHF ratio .

Fühlbare Leistung (SHF): SHF für hochfühlbaren Leistungsmodus = SHF für normale Leistungstabelle x SHF-Verhältnis.

Αισθητή απόδοση (SHF): SHF για λειτουργία υψηλής ευαισθησίας = SHF για πίνακα κανονικών αποδόσεων X αναλογία SHF .

Capacidad sensible (FCS): SHF para el modo de alta sensibilidad = SHF para la tabla de capacidad normal X relación SHF.

Capacité sensible (FCS (Facteur de chaleur sensible) – en anglais : SHF) : FCS pour le mode sensibilité élevée (« High ») = FCS du tableau des capacités normales x rapport FCS.

Capacità sensibile (SHF): SHF per modalità ad alta capacità sensibile = SHF per tabella capacità normali X rapporto SHF.

Gevoeligheidscoëfficiënt (WGF (warmtegevoelsfactor)– in het Engels "SHF"): WGF voor de modus grote ("High") gevoeligheid = WGF uit de tabel met normale capaciteiten x WGF-ratio.

Ощутимая производительность (SHF): SHF для режима с высоким коэфф.

ощутимого охлаждения = SHF для нормального режима, таблица X коэфф. SHF.

Algılanabilir kapasite (SHF): Yüksek algı modu için SHF = Normal kapasite tablosundaki SHF değeri x SHF oranı.

3. In case of SHF is bigger than 1 , SHF is "1"

Für den Fall, dass SHF größer als 1 ist, wird SHF als "1" angenommen.

Σε περίπτωση που το SHF είναι μεγαλύτερο από 1, το SHF είναι "1"

En caso de que SHF sea superior a 1 , SHF equivale a "1"

Si FCS est supérieur à 1, utilisez « 1 » pour FCS.

Qualora il valore SHF sia maggiore di 1 , SHF è "1"

Indien WGF groter is dan 1, neem dan "1" voor WGF.

Если SHF больше 1, то SHF равен "1"

SHF değeri 1'den büyükse, SHF değeri "1" kabul edilmelidir

6 Dimensional drawings

6 - 1 Dimensional Drawings

FXKQ25,32,40MA

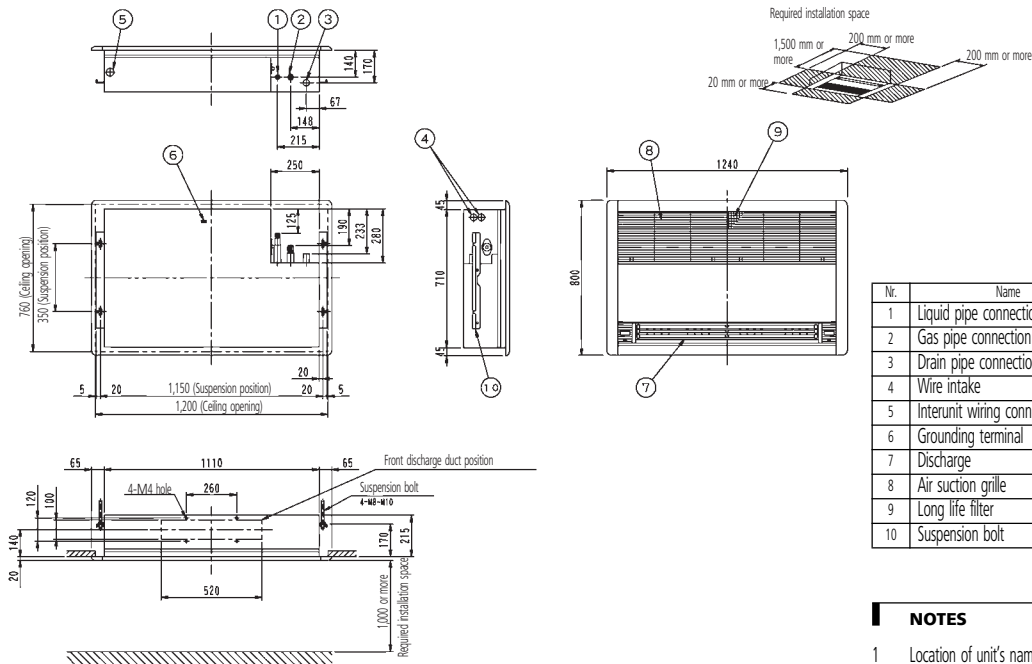

Nr.	Name	Description
1	Liquid pipe connection	ø 6.4 Flare connection
2	Gas pipe connection	ø 12.7 Flare connection
3	Drain pipe connection	VP25 (O.D. ø 32)
4	Wire intake	
5	Interunit wiring connection	
6	Grounding terminal	Inside switch box (M4)
7	Discharge	
8	Air suction grille	
9	Long life filter	
10	Suspension bolt	

NOTES

- Location of unit's name plate:
 - For main body: Bottom part of fan housing inside of air suction grille.
 - For decoration panel: Service lid face inside of air suction grille.
- When installing an optional accessory, refer to the installation drawings.

3D038840

FXKQ63MA

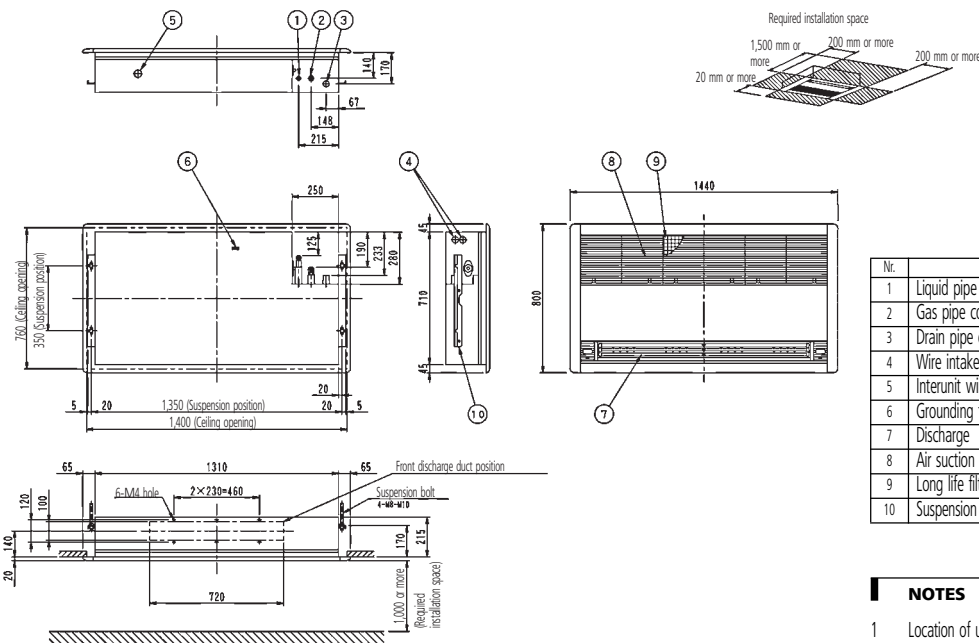

Nr.	Name	Description
1	Liquid pipe connection	ø 9.5 Flare connection
2	Gas pipe connection	ø 15.9 Flare connection
3	Drain pipe connection	VP25 (O.D. ø 32)
4	Wire intake	
5	Interunit wiring connection	
6	Grounding terminal	Inside switch box (M4)
7	Discharge	
8	Air suction grille	
9	Long life filter	
10	Suspension bolt	

NOTES

- Location of unit's name plate:
 - For main body: Bottom part of fan housing inside of air suction grille.
 - For decoration panel: Service lid face inside of air suction grille.
- When installing an optional accessory, refer to the installation drawings.

3D038841

7 Centre of gravity

7 - 1 Centre of Gravity

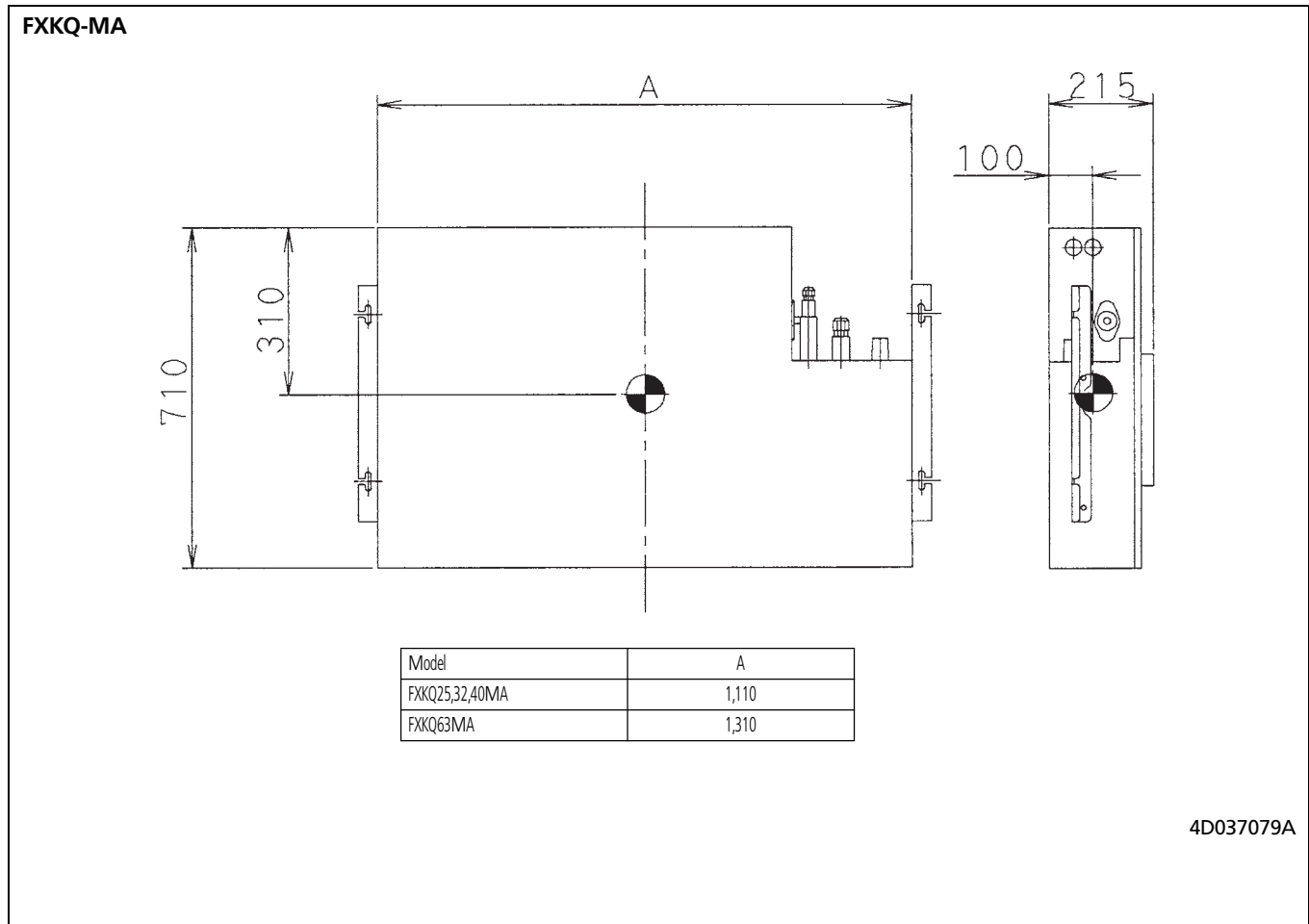

8 Piping diagrams

8 - 1 Piping Diagrams

FXKQ-MA

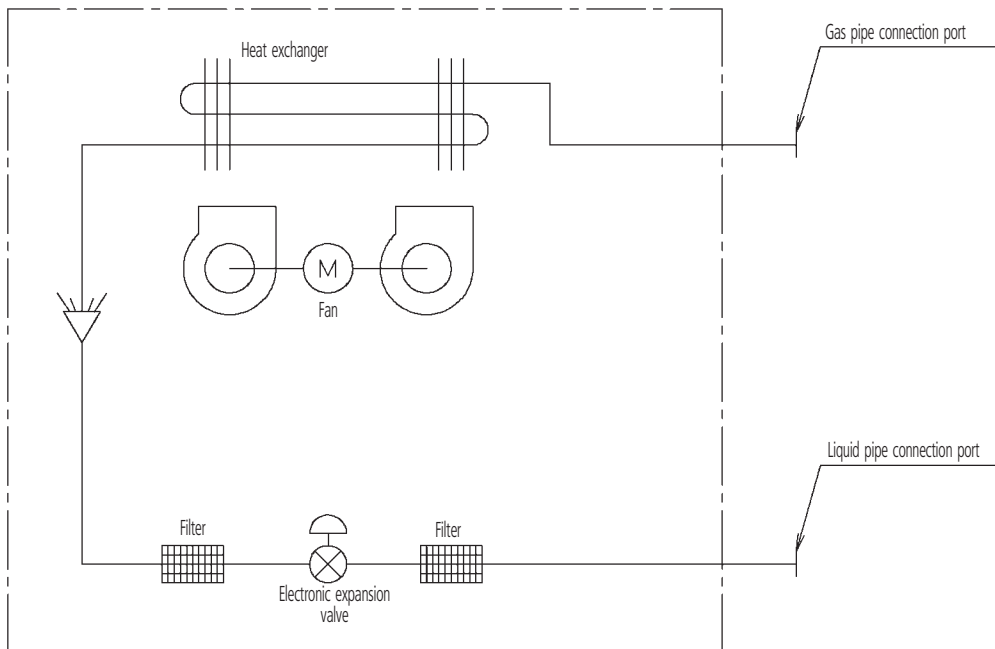

Piping connection diameters

Model	Gas	Liquid
FXKQ25,32,40MA	ø12.7	ø6.4
FXKQ63MA	ø15.9	ø9.5

4D034245D

9 Wiring diagrams

9 - 1 Wiring Diagrams - Single Phase

FXKQ-MA

WIRING DIAGRAM

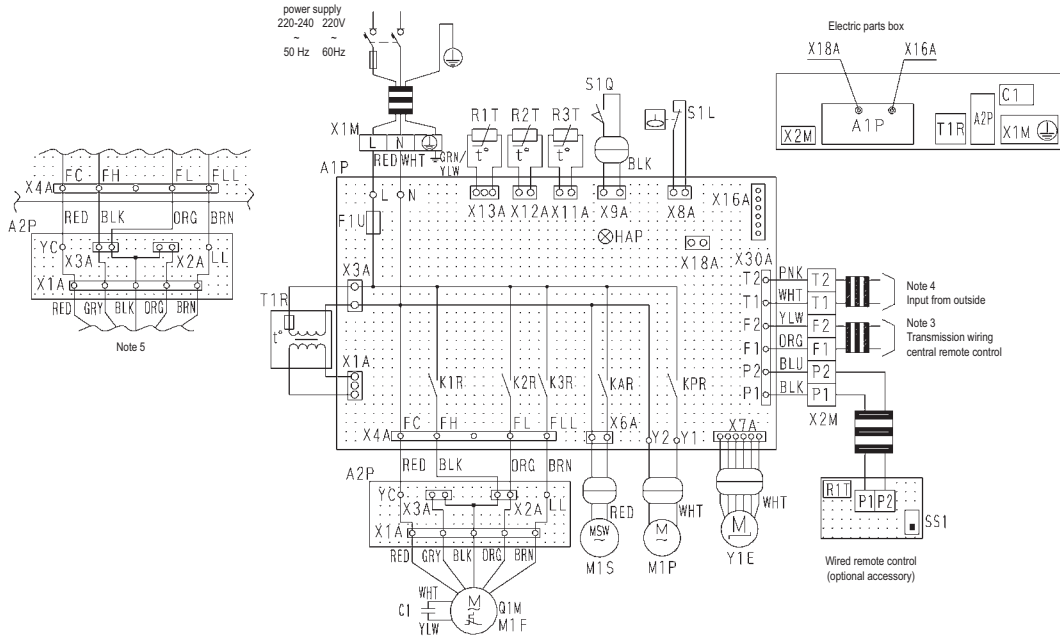

Indoor unit		R1T	Thermistor (air)	Wired remote control	
A1P	Printed circuit board	R2T • R3T	Thermistor (coil)	R1T	Thermistor (air)
A2P	Terminal board	S1L	Float switch	SS1	Selector switch (main/sub)
C1	Capacitor (M1F)	S1Q	Limit switch (swing flap)	Connector (adaptor for wiring)	
F1U	Fuse (Ⓟ, 5A, 250V)	T1R	Transformer (220-240V/22V)	X16A	Connector (adapter for wiring)
HAP	Light emitting diode (service monitor green)	X1M	Terminal block (power)	X18A	Connector (wiring adapter for electrical appendices)
K1R-K3R	Magnetic relay (M1F)	X2M	Terminal block (control)		
KAR	Magnetic relay (M1S)	Y1E	Electronic expansion valve		
KPR	Magnetic relay (M1P)				
M1F	Motor (indoor fan)				
M1P	Motor (drain pump)				
M1S	Motor (swing flap)				
Q1M	Thermo switch (M1F embedded)				

3D039564C

NOTES

- : Terminal strip ⊞ : connector -○- : terminal ⊕ : protective earth (screw)
- ⚡ : Field wiring
- In case using central remote control, connect to the unit in accordance with the attached instruction manual.
- When connecting the input wires from outside, forced OFF or ON/OFF control operation can be selected by remote control. In details, refer to the installation manual attached the unit.
- In case high E.S.P. operation, change over the wiring connecting from X2A to X3A.
- Symbols show as follows. (PNK: pink, WHT: white, YLW: yellow, ORG: Orange, BLU: blue, BLK: black, RED: red, BRN: brown, GRY: gray)
- Use copper conductors only.

10 Sound data

10 - 1 Sound Level Data

FXKQ-MA

Model	Sound pressure level - 220 V		Sound pressure level - 240 V		Sound power level
	H	L	H	L	
FXKQ25MA	38	33	40	35	*
FXKQ32MA	38	33	40	35	*
FXKQ40MA	40	34	42	36	*
FXKQ63MA	42	37	44	39	*

* data were not available at the time of publication

NOTES

- 1 Reference acoustic pressure $0\text{dB}=0.0002\mu\text{bar}$
- 2 Operation noise differs with operation and ambient conditions
- 3 Measuring place: anechoic chamber

10 Sound data

10 - 2 Sound Pressure Spectrum

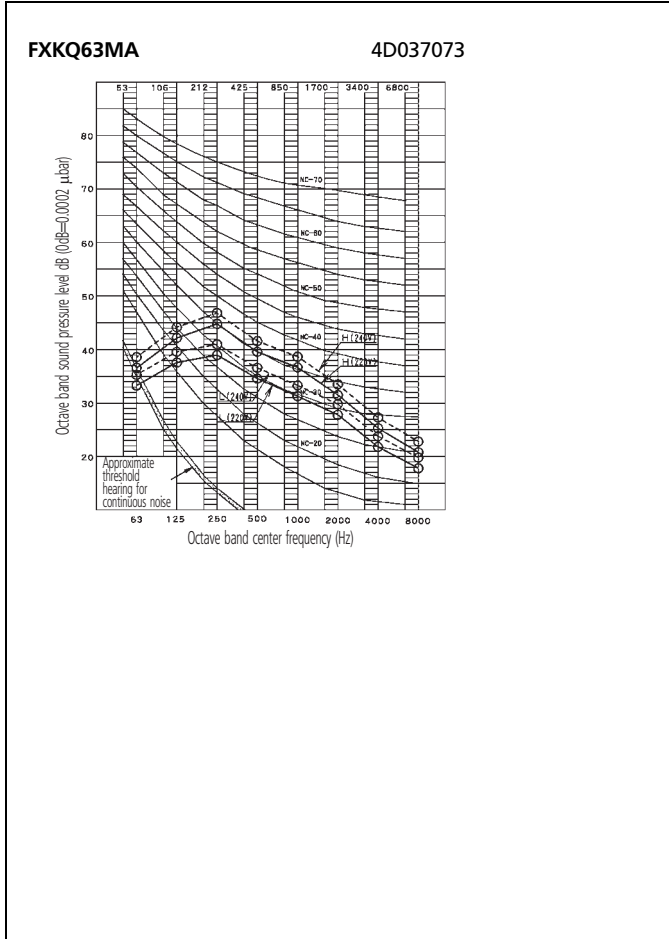
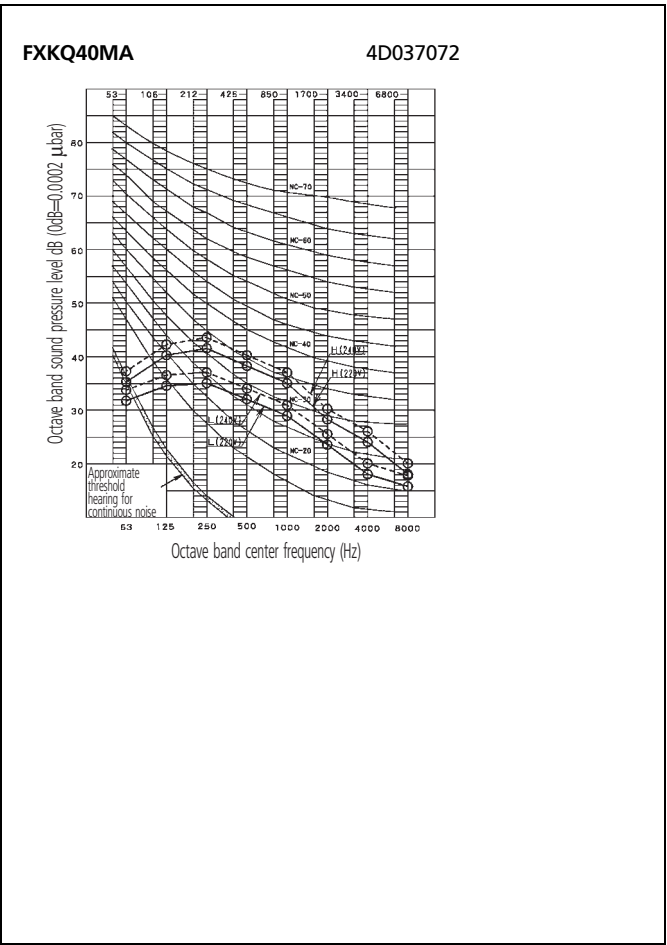
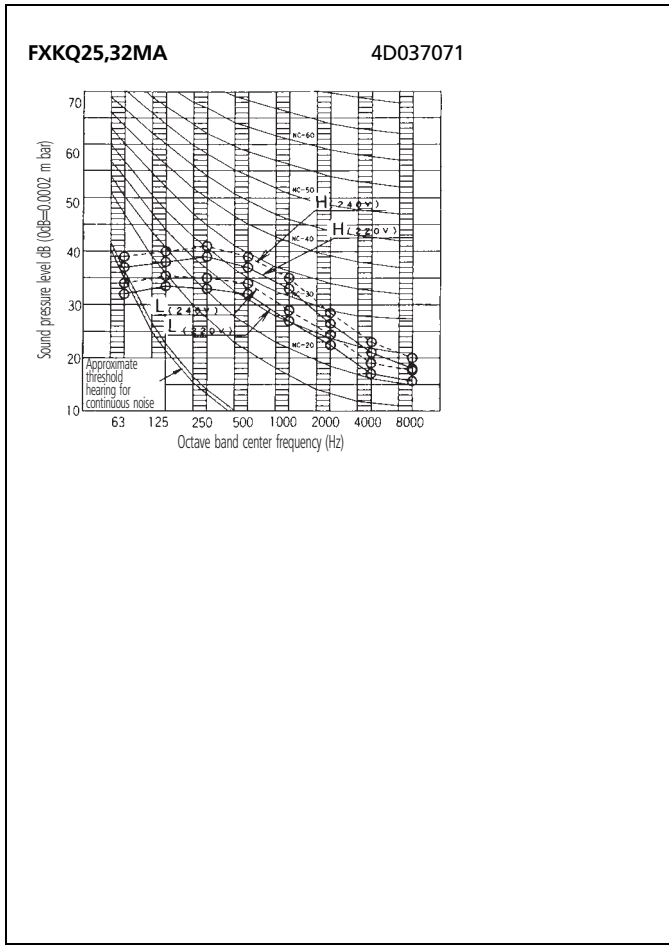

11 Air flow patterns

11 - 1 Air Flow Pattern - Heating

FXKQ63MA

Heating air velocity distribution

Lower air blow

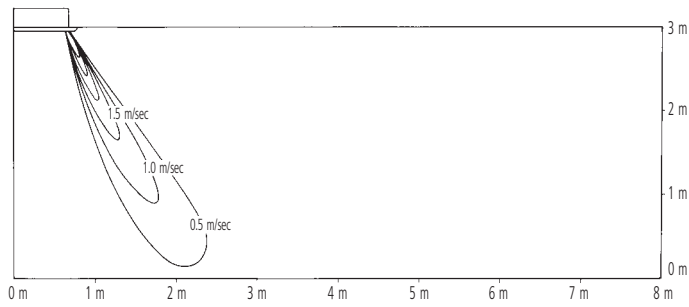

Heating temperature distribution

Lower air blow

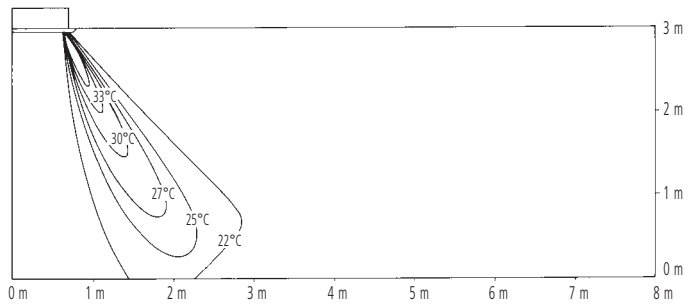

NOTES

- 1 The corner type is applicable on a high ceiling. The standard set-up height is 3 m. Shown here is the measurement distribution at the ceiling height of 3 m.

12 Installation

12 - 1 Drainage Instructions

Rig the drain pipe as shown below and take measures against condensation. Improperly rigged piping could lead to leaks and eventually wet furniture and belongings.



Install the drain pipes.

- Keep piping as short as possible and slope it downwards so that the air does not remain trapped inside the pipe.
- The diameter of the drain pipe should be larger than or equal to the diameter of the connecting pipe (Vinyl tube; pipe size: 25 mm; outer dimension: 32 mm).
- Use the attached drain hose and clamp metal. Insert the drain hose into the drain socket, up to the white tape. Tighten the clamp until the screw head is less than 4 mm from the hose.

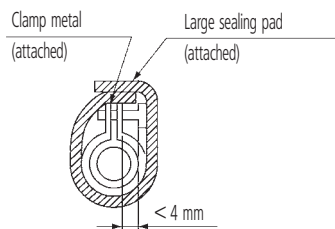
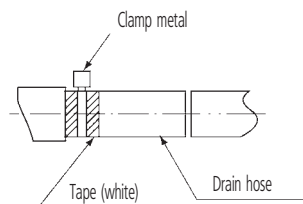

CAUTION

- 1 Installing the unit at an angle opposite to the drain piping might cause leaks.
- Wrap the attached sealing pad over the clamp and drain hose to insulate.
 - Insulate the drain hose inside the building.
 - Insulate the clamp and drain hose with the attached large sealing pad. If the drain hose cannot be sufficiently set on a slope, execute the drain raising piping. Secure a downward gradient of 1/100 or more for the drain pipe. To accomplish this, mount supporting brackets at an interval of 1 - 1.5 m.

Precautions when installing drain-up piping.

- Make sure the drain-up piping is maximum 330 mm high. Install the drain-up piping horizontally, and make sure it is not further than 300 mm from the base of the drain socket.

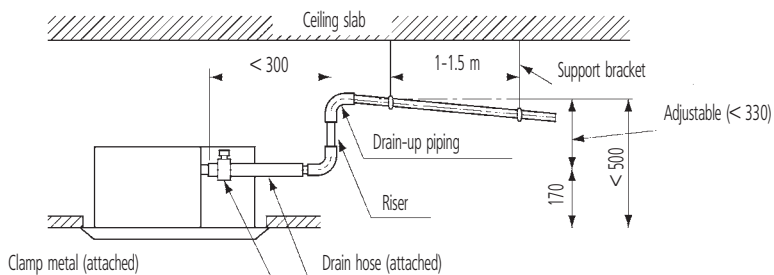

- Use the following outline if installing concentrated drain piping. If converging multiple drain pipes, install according to the procedure shown on the right.

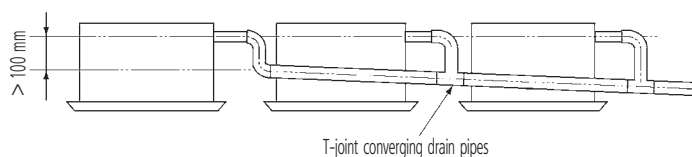

Select converging drain pipes whose gauge is suitable for the operating capacity of the unit.

12 Installation

12 - 1 Drainage Instructions

When piping work is finished

- Check if drainage flows smoothly. Open the inspection opening, add approximately 1,000 cc of water slowly into the drain pan and check drainage flow.

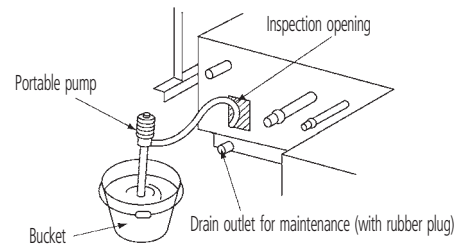

NOTE

- 1 Use the drain outlet for maintenance to drain water from the drain pan.

When electric wiring work is finished

- Check drainage flow during COOL running, explained under "TEST OPERATION"

When electric wiring work is not finished

- Remove the electric parts box lid, connect power supply and remote control to the terminals.
Next, press the inspection/test operation button "TEST" on the remote control. The unit will engage the test operation mode.
Press the operation mode selector button " " until selection FAN OPERATION " ". Then, press the ON/OFF button " ". The indoor unit fan and drain pump will start up. Check that the water has drained from the unit. Press "TEST" to go back to the first mode.

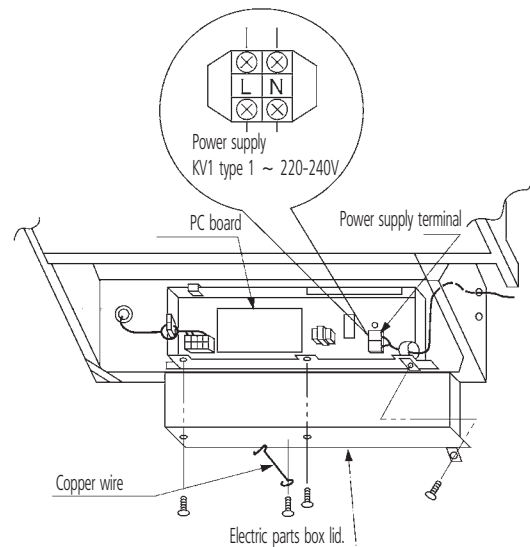

CAUTION

- 1 Do not connect the drain piping directly to sewage pipes that smell of ammonia. The ammonia in the sewage might enter the indoor unit through the drain pipes and corrode the heat exchanger.

12 Installation

12 - 2 Suspension Bolt Pitch Position

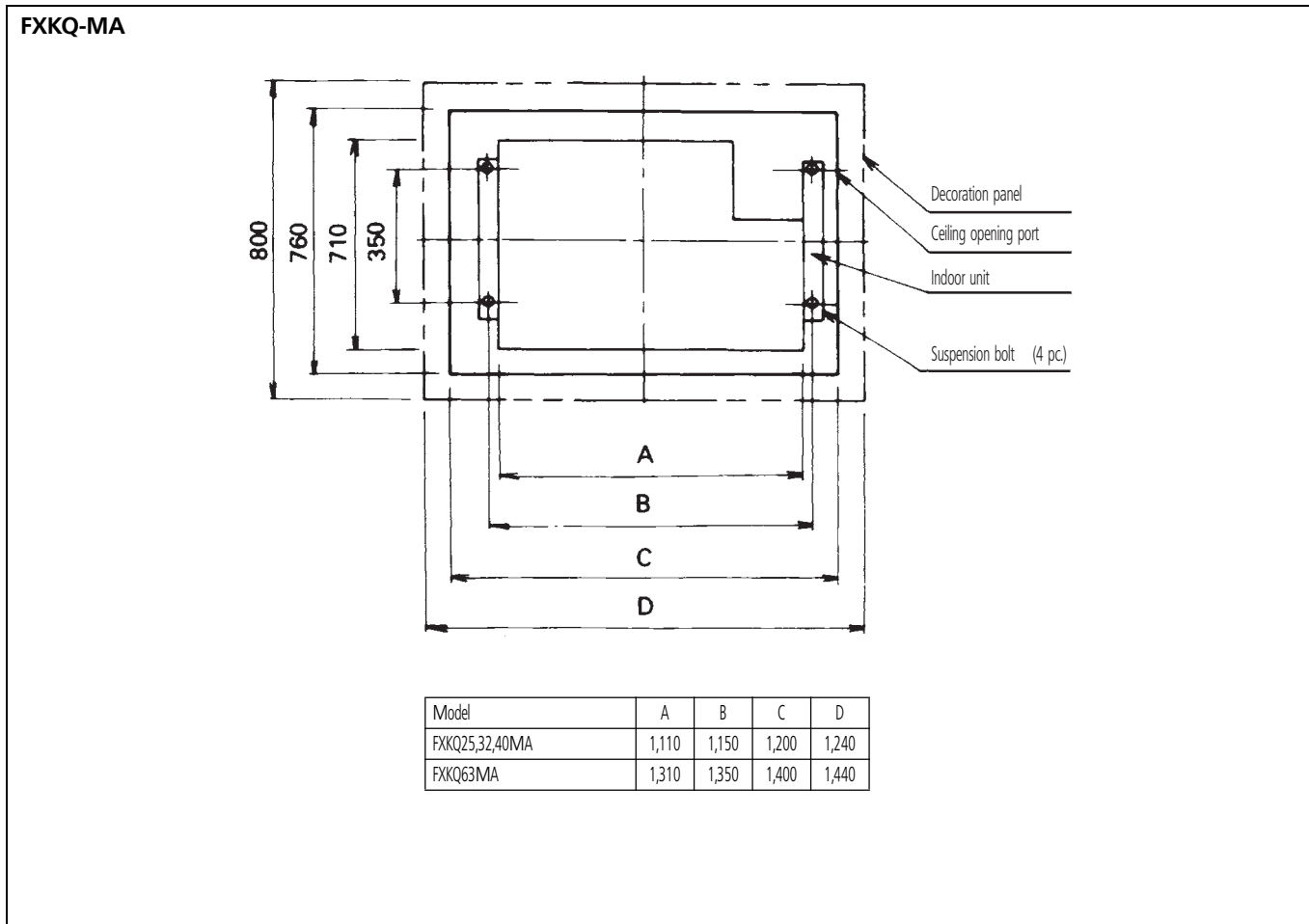

12 Installation

12 - 3 Service Space

FXKQ-MA

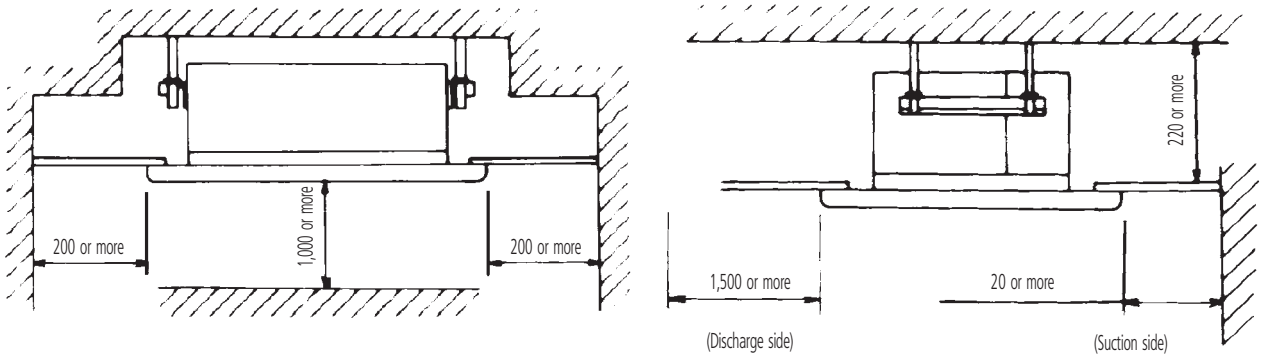

NOTES

- 1 Above figures mean minimum values



Daikin's unique position as a manufacturer of air conditioning equipment, compressors and refrigerants has led to its close involvement in environmental issues. For several years Daikin has had the intention to become a leader in the provision of products that have limited impact on the environment. This challenge demands the eco design and development of a wide range of products and an energy management system, resulting in energy conservation and a reduction of waste.



VRV® products are not within the scope of the Eurovent certification programme.

The present publication is drawn up by way of information only and does not constitute an offer binding upon Daikin Europe N.V. Daikin Europe N.V. has compiled the content of this publication to the best of its knowledge. No express or implied warranty is given for the completeness, accuracy, reliability or fitness for particular purpose of its content and the products and services presented therein. Specifications are subject to change without prior notice. Daikin Europe N.V. explicitly rejects any liability for any direct or indirect damage, in the broadest sense, arising from or related to the use and/or interpretation of this publication. All content is copyrighted by Daikin Europe N.V.

Daikin products are distributed by: